

# **Technical Reference Manual for OEMs**

**HP Models 743, 744, and 748**



**HP Part No. A4511-90601  
Printed in USA**

**August, 1997**

**Special Online Edition 1199**

## Legal Notices

### Manual Content

Information in this manual is subject to change without notice.

*Hewlett-Packard makes no warranty of any kind about this manual, including, but not limited to, the implied warranties of merchantability and fitness for a particular purpose.*

Hewlett-Packard shall not be liable for errors contained herein or direct, indirect, special, incidental, or consequential damages about the furnishing, performance, or use of this material.

Copyright © Hewlett-Packard Company 1994, 1995, 1996, 1997, 1999. This document contains information which has been protected by copyright. All rights are reserved. Reproduction, adaptation, or translation without prior written permission is prohibited, except as allowed under the copyright laws.

Software mentioned and documentation is based in part on the Fourth Berkeley Software Distribution under license from the Regents of the University of California.

### Restricted Rights Legend

Use, duplication, or disclosure by the United States Government is subject to restrictions as set forth in subparagraph (c) (1) (ii) of the Rights in Technical Data and Computer Software clause at FARs 52.227.7013.

Hewlett-Packard Company

Embedded Systems Operation

3000 Minuteman Road

Andover, MA 01810

---

## Printing History

The printing date and edition number shown is the current edition of this manual. The printing date changes when a new edition is printed. Minor changes may be made at reprint without changing the printing date.

August 1994, Edition 1

April 1995, Edition 2

September 1995 Edition 3

June 1996, Edition 4

December 1996, Edition 5

March 1997, Edition 6

August 1997, Edition 7

## Safety Symbols and Conventions

This manual uses the following conventions:

---

**NOTE:**

---

Notes contain important information set off from the text.

---

**CAUTION:**

---

Caution messages indicate procedures which, if not observed, could result in damage to equipment. Do not proceed beyond a CAUTION sign until the indicated conditions are fully understood and met.

---

**WARNING:**

---

Warning messages indicate procedures or practices which, if not observed, could result in personal injury. Do not proceed beyond a WARNING sign until the indicated conditions are fully understood and met.

---

---

# Contents

## 1 General Information

### Model 743 and Model 744 VME Board Computers 1-2

Product Description 1-2

1-6

Supported Configurations 1-7

Model 743 Memory 1-7

Model 744 Memory 1-7

System Graphics 1-8

Model 743 and Model 744 External Devices 1-9

Keyboard and Mouse 1-9

Model 743 and Model 744 Cables 1-9

Model 743 and Model 744 Functional Description 1-11

Model 744 Block Diagram 1-14

CPU Circuit 1-15

Boot ROM Circuit 1-16

Graphics Circuit 1-16

Model 743 Memory Controller Circuit 1-17

Model 744 Memory Controller Circuit 1-17

LED Displays 1-18

I/O Controller ASIC 1-18

VME Controller ASIC 1-23

I/O Expansion 1-25

I/O Expansion Block Diagrams 1-26

### Model 748 Ruggedized Workstation 1-27

Product Description 1-27

Supported Configurations 1-27

Model 748 Ruggedized Workstation Functional Description 1-30

Environmental Specifications for Monitors 1-31

Original Equipment Manufacturer (OEM) Support Overview 1-32

Standard Support 1-32

Additional OEM Support Programs 1-32

## 2 References

HP Hardware Manuals 2-2

---

## Contents

Installation Guides 2-2  
Service Manuals 2-2  
Diagnostic Manuals 2-3  
HP Software Manuals 2-4

### 3 Quality

Safety Compliance Programs 3-2

Introduction 3-2

Underwriter's Laboratories (USA) 3-2

Canadian Standards Association (Canada) 3-2

TUV Rheinland (Germany) 3-2

Electromagnetic Compatibility Programs 3-3

Introduction 3-3

Federal Communications Commission (USA) 3-3

European Community 3-3

Voluntary Control Council for Interference (Japan) 3-3

Overview 3-4

Electromagnetic Field Emissions Test Suite 3-4

Electromagnetic Field Immunity/Susceptibility Test Suite 3-5

Line Transients Immunity/Susceptibility Test Suite 3-6

Climatic and Dynamic Environmental Ruggedness 3-8

Introduction 3-8

Overview 3-8

Temperature, Humidity, and Altitude Test Suite 3-9

Acoustics 3-11

Sound Power Levels 3-11

Statistical Reliability 3-12

Annualized Failure Rate Projections 3-12

Mean Time Between Failure Computations 3-12

---

## Contents

### **4 Mechanical Information**

Model 743 and Model 744 VME Board Computers 4-2

Key Components 4-2

Air Flow Requirements 4-4

Interface Connectors 4-6

Mechanical Dimensions 4-7

Model 748 Chassis and Modules 4-20

Weights 4-27

Mounting and Support 4-28

Mechanical Drawings 4-28

Conversion Cables 4-28

Chassis Parts and Models 4-29

### **5 Electrical Information**

Video Connector Pinouts 5-3

Audio Connector Pinouts 5-8

HP Parallel Connector Pinouts 5-10

RS-232 Connector Pinouts 5-12

AUI LAN Connector Pinouts 5-14

Single-Ended SCSI Connector Pinouts 5-16

FW SCSI Connector Pinout 5-18

PS/2 Connector Pinouts 5-20

VME Connector Pinouts 5-21

Real-Time Clock (RTC) Battery Information 5-37

Battery Specifications 5-37

Video Output Signal Specifications 5-37

Video Timing Specifications 5-37

### **6 Power Requirements**

Power Distribution 6-2

FW SCSI Estimated Power Consumption 6-6

Monitor Power Specifications 6-6

---

## Contents

Power Budgeting 6-7

### **7 Product Design Considerations**

Application Information 7-2

VME Services Updates 7-2

VME Systems Design Considerations for Models 743, 744, and 748 7-2

System Integration 7-3

Hardware Power On Information 7-3



---

## **General Information**

The General Information Chapter provides general information on the Model 743 and Model 744 VME Board Computers, the Model 748 Ruggedized Workstation, environmental specifications for the supported monitors, and OEM support.

## Model 743 and Model 744 VME Board Computers

The sections that follow contain the Model 743 and Model 744 VME Board Computer product descriptions and functional descriptions.

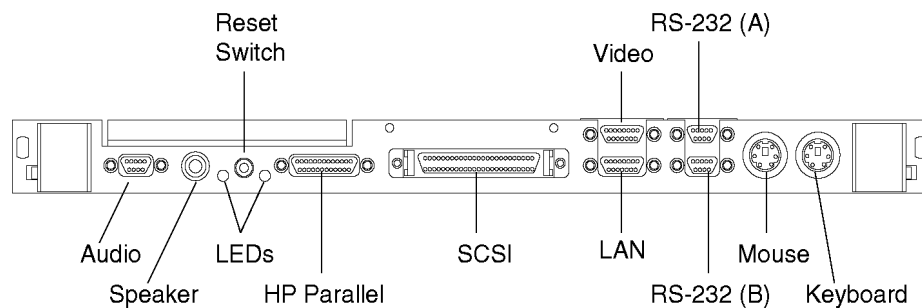
### Product Description

HP Model 744 VME Board Computers are based on the PA 7300LC CPU. HP Model 743 VME Board Computers are based on the PA 7100LC CPU. Running either HP-UX or HP-RT operating systems, they are typically installed in a VME backplane.

- Model 744/165L: HP-UX operating system, 165 MHz system clock
- Model 744rt/165L: HP-RT operating system, 165 MHz system clock
- Model 744/132L: HP-UX operating system, 132 MHz system clock
- Model 744rt/132L: HP-RT operating system, 132 MHz system clock
- Model 743i/64: HP-UX operating system, 64 MHz system clock
- Model 743i/100: HP-UX operating system, 100 MHz system clock
- Model 743rt/64: HP-RT operating system, 64 MHz system clock
- Model 743rt/100: HP-RT operating system, 100 MHz system clock

Each board computer is complete with the core I/O of an HP-PA workstation in a single-slot VME solution with expandability for more I/O or RAM in a two-slot or three-slot VME solution. The core design includes application-specific integrated circuits (ASICs) that add VME and real-time features.

Figure 1-1 illustrates the front panel of Model 743 and Model 744 Board Computers.



**Figure 1-1**

**Model 743 and Model 744 VME Board Computer Front View**

Table 1-2 lists the feature sets of the Model 743i VME Board Computer

**Table 1-1 Model 743i (A4260A) and 743rt (A4261A) Features**

Feature	Specifications
VME Slot Configuration	Single Slot - Standard features Two Slots - GSC expansion kit (A4219A), or PMC Bridge Adapter (A4504A) Three Slots - ATM card (J3420A) and GSC expansion kit (A4219A), or PCI Mezzanine Card (PMC) Expansion Adapter (A4509A)
CPU	64 or 100 MHz PA-RISC PA7100-LC 256 KB cache 1 KB on-chip instruction cache Floating point coprocessor 64-bit wide ECC memory controller
Clocks	Battery backed real-time clock Interval timers (one 32-bit and two 16-bit) Watchdog timer
Operating System	HP-UX 9.05 or later, or HP-RT 2.21 patch or later
User Interface	HP VUE graphical user interface (HP-UX 9.05 or later) HP CDE graphical user interface (HP-UX 10.10 or later) HP-RT
Compatibility	Source and binary code compatible with the Series 700 product family
Monitors	Single or multiple display depending on the number of installed graphics options (on-board and/or external). HP-UX 9.x supports up to two displays and HP-UX 10.x supports up to three displays. Color monitors 17-inch, 1280 x 1024 19-inch, 1280 x 1024 Terminals - Text only connected to RS-232C port
Optional Graphics	On-board (option 202=64MHz w/graphics or option 204=100MHz w/graphics)
Main Memory	Single VME Slot Configuration - 32 to 128 MB (A4265A=32MB, or A4266A=64MB) Two VME Slots Configuration - 32 to 256 MB
Standard Features	Internal SCSI-2 single-ended bus CD-Quality audio (not supported on HP-RT) Two asynchronous RS-232-C ports One HP parallel port One LAN AUI port Two mini-DIN PS/2 ports Two sites for memory cards Video connector for onboard graphics
Two Slot Upgrades	PMC Bridge Adapter (A4504A) with two PMC sites GSC Expansion kit (A4219A) with two GSC sites

**Table 1-1 Model 743i (A4260A) and 743rt (A4261A) Features**

Feature	Specifications
Three Slot Upgrades	PMC Expansion Adapter (A4509A) with two additional PMC sites ATM card (J3420A) (Requires GSC expansion kit A4262A - one additional site supported for 3x5 GSC card) (Not available with HP-RT)

Table 1-2 lists the feature sets of the Model 744/132L VME Board Computer

**Table 1-2 Models 744/132L (A4500A) and 744rt/132L (A4520A) Features**

Feature	Specifications
VME Slot Configuration	Single Slot - Standard features  Two Slots - PMC Bridge Adapter (A4504A) GSC expansion kit (A4219A) HCRX graphics (A4315A or A4316A) FWD SCSI (A4268A) 8-plane graphics (A4267A)  Three Slots - ATM card (J3420A) and expansion kit (A4219A), or PMC Expansion Adapter (A4509A)
CPU	132 MHz PA-RISC PA7300-LC 128 KB Primary internal cache (64 KB instruction cache, 64KB data cache)
Clocks	Battery backed real-time clock Interval timers (one 32-bit and two 16-bit) Watchdog timer
Operating System	HP-UX 10.20 or later, or HP-RT 2.21 patch or later
User Interface	HP VUE graphical user interface (HP-UX) HP CDE graphical user interface (HP-UX) HP-RT
Compatibility	Source and binary code compatible with the Series 700 product family
Monitors	Single or multiple display depending on the number of installed graphics options (on-board and/or external)  Color monitors 17-inch, 1280 x 1024 19-inch, 1280 x 1024  Terminals - Text only connected to RS-232C port
Optional Graphics	Onboard (A4500A option 120) PMC Visualize-EG Graphics Card (A4979A) Note: A maximum of four graphics displays are allowed with HP-UX 10.10 ACE and later releases, a maximum of one graphics display with HP-RT.
Main Memory	Single VME Slot Configuration - 64 to 256 MB A4503A, A4449A, A6005A) Two VME Slots Configuration - 64 to 1024 MB

**Table 1-2                    Models 744/132L (A4500A) and 744rt/132L (A4520A) Features**

Feature	Specifications
Standard Features	Internal SCSI-2 single-ended bus CD-Quality audio (not supported on HP-RT) Two asynchronous RS-232-C ports One HP parallel port One LAN AUI port Two mini-DIN PS/2 ports One site for memory card stack Video connector for onboard graphics Conversion cables are included in base kit.
Two Slot Upgrades	PMC Bridge Adapter (A4504A) with two PMC sites GSC Expansion kit (A4219A) with two GSC sites)
Three Slot Upgrades	PMC Expansion Adapter (A4509A) ATM card (J3420A) (Requires GSC expansion kit A4219A - one additional site supported for 3x5 GSC card) (Not available with HP-RT.)

Table 1-3 lists the feature sets of the Model 744/165L VME Board Computer

**Table 1-3                    Model 744/165L (A4511A) and 744rt/165L (A4512A) Features**

Feature	Specifications
VME Slot Configuration	Single Slot - Standard features  Two Slots - PMC Bridge Adapter (A4504A) GSC expansion kit (A4219A) Three Slots -ATM card (J3420A) and expansion kit (A4219A), or PMC Expansion Adapter (A4509A)
CPU	165 MHz PA-RISC PA7300-LC 128 KB Primary internal cache (64 KB instruction cache, 64KB data cache) 512 KB Secondary external cache
Clocks	Battery backed real-time clock Interval timers (one 32-bit and two 16-bit) Watchdog timer
Operating System	HP-UX 10.20 or later, or HP-RT 3.01 patch or later
User Interface	HP VUE graphical user interface (HP-UX) HP CDE graphical user interface (HP-UX) HP-RT
Compatibility	Source and binary code compatible with the Series 700 product family

**Table 1-3 Model 744/165L (A4511A) and 744rt/165L (A4512A) Features**

Feature	Specifications
Monitors	Single or multiple display depending on the number of installed graphics options (on-board and/or external)  Color monitors 17-inch, 1280 x 1024 19-inch, 1280 x 1024  Terminals - Text only connected to RS-232C port
Optional Graphics	Onboard (A4500A option 120) PMC Visualize-EG Graphics Card (A4979A) Note: A maximum of four graphics displays are allowed with HP-UX 10.10 ACE and later releases, a maximum of one graphics display with HP-RT.
Main Memory	Single VME Slot Configuration - 64, 128, or 256 MB (A4503A, A4449A or A6005A) Two VME Slots Configuration - 64 MB to 1024 MB
Standard Features	Internal SCSI-2 single-ended bus CD-Quality audio (not supported on HP-RT) Two asynchronous RS-232-C ports One HP parallel port One LAN AUI port Two mini-DIN PS/2 ports One site for memory card stack Video connector for onboard graphics Conversion cables are included in base kit.
Two Slot Upgrades	PMC Bridge Adapter (A4504A) with two PMC sites GSC Expansion kit (A4219A) with two GSC sites
Three Slot Upgrades	PMC Expansion Adapter (A4509A) ATM card (J3420A) (Requires GSC expansion kit A4219A - one additional site supported for 3x5 GSC card) (Not available with HP-RT.)

## Supported Configurations

This section discusses the following supported configurations: memory, system graphics, external devices, cables, and keyboard and mouse.

Hewlett-Packard only supports products having Hewlett-Packard approved parts, accessories, peripherals, operating systems, and application programs.

### Model 743 Memory

Standard memory is Error Checking and Correcting (ECC) RAM cards. Up to four RAM cards may be installed. RAM upgrades include:

- HP A4265A 32 MB RAM Card
- HP A4266A 64 MB RAM Card

Model 743 VME Board Computers use custom 60-ns TSOP-based RAM cards. Use of TSOP packaging allows adequate cooling in single-slot installations.

Two stack locations for RAM cards are used. The primary RAM stack is on the right side, the secondary one is on the left side. Only one RAM card can be used in the secondary, or left stack, if a GSC+ card is added in the secondary GSC+ slot. Three RAM cards can be used in the primary stack. If more than one RAM card is used in either stack, the optional HP 4262A GSC Expansion Kit or A4504A PMC Bridge Adapter (HP-UX only) must be installed; then the board computer will occupy two VME slots in a VME chassis.

RAM cards may be placed in any order. A higher density card can be added on top of a low density card and vice versa.

### Model 744 Memory

Standard memory is Error Checking and Correcting (ECC) RAM cards. Up to four RAM cards may be installed. RAM upgrades include:

- HP A4501A 64 MB RAM Card
- HP A4449A 128 MB RAM Card
- HP A6005A 256 MB RAM Card

Model 744 VME Board Computers use custom TSOP-based RAM cards. Use of TSOP packaging allows adequate cooling in single-slot installations.

There is only one stack location for RAM cards on the Model 744. Memory cards are stacked in the same orientation; that is, there is no need to rotate cards 180 degrees relative to the previously inserted card as in the Model 743. If more than one RAM card is used, the optional HP 4219A GSC expansion kit must be installed; then the board computer will occupy two VME slots in a VME chassis.

When mixing the 128 MB and 256 MB RAM card with cards of a different capacity, the 128 MB and 256 MB card(s) must always be in the lower memory slots.

**System Graphics**

The Model 743 and Model 744 Board Computers can be ordered with optional on-board graphics.

The Model 744 supports up to four optional PMC Visualize-EG graphics cards.

The HP-UX 10.20 ACE operating system supports up to four displays.

The HP-RT operating system supports only one graphics display.

Table 1-4 shows the display resolutions and refresh rates that are supported on current and older graphics devices.

**NOTE:**

The HCRX graphics options support a Frame Buffer of 1280 by 1024; therefore, the monitor selected must support a resolution of 1280 by 1024.

**Table 1-4 Supported Graphics Configurations**

Display Pixel Resolution	Display Refresh Rate	On-board Graphics	HP A4267A 8-Plane GSC Card	HP A4315A 8-Plane or HP A4316A 24-Plane HCRX Graphics
1280x1024*	75 Hz 72 Hz	•*	•*	• •
1024 x 768*	75 Hz 70 Hz	•*	•*	
800 x 600	75 Hz	•	•	
640 X 480	75 Hz 60 Hz	•	•	

With the D8900A monitor, HP-UX 10.20 ACE or 11.00, and the A4267A graphics card or Model 743 onboard graphics, these resolutions are not supported.



### Model 743 and Model 744 External Devices

The Model 743 and Model 744 support the following external devices:

- LAN Transceiver (Medium Attachment Unit)
  - HP 28641B ThinLAN Ethernet Transceiver (order number A2670A)
  - HP 28685B Ethertwist Transceiver (order number A2671A)
  - HP 28683A Fiber Optic Hub/Transceiver
- Speaker: 8 ohm impedance with 1/8-inch sub-miniature stereo connector
- Single-ended SCSI through the onboard SE SCSI adapter

### Keyboard and Mouse

The Model 743 and Model 744 support the mouse with mini-DIN connector (PS/2) and keyboard with mini-DIN connector (PS/2) included in the HP A4030D Localization Kit.

### Model 743 and Model 744 Cables

Table 1-5 and Table 1-6 show the part numbers for standard cables and conversion cables used to interface with the Model 743 and Model 744 I/O backplanes.

Drawings showing mechanical and electrical characteristics for these cables are available. Refer to chapter 4 in this manual for more information.

**Table 1-5 Model 743 and Model 744 Standard Cables**

Product Number	Interface	Cable Type
HP 24524G	RS-232	3-meter terminal cable; 9-pin female to 25-pin male
HP 24524H	RS-232	3-meter modem cable; 9-pin female to 25-pin female
HP C2950A	HP Parallel	DB 25-pin male to 36-pin Centronics male
HP 92284A	HP Parallel	DB 25-pin male to 25-pin male
HP K2296	SCSI-2	0.9 meter high-density 50-pin to standard bail lock <sup>a</sup>

a. Additional lengths are available.

Conversion cables provide a way to connect a standard cable to the high-density connectors on the Model 743 and Model 744 front panels.

All conversion cables, except the A4167A, are 762 plus/minus 30mm (30 plus/minus 1.18 inch) long. The A4167A cable is 250 mm (10 inches) long.

**Table 1-6****Model 743 and Model 744 Conversion Cables**

<b>Product Number</b>	<b>Interface</b>	<b>Cable Type</b>
HP A4300A	HP parallel	High-density 25-pin to standard 25-pin female
HP A4301A	RS-232	High-density 9-pin to standard 9-pin male
HP A4302A	Audio	High-density 9-pin to stereo line-in
HP A4303A	LAN	High-density 15-pin to 15-pin AUI
HP A4304A	Video (743)	High-density 15-pin to standard 15-pin female
HP A4223A	Video (744)	High-density 15-pin to standard 15-pin female
HP A4305A	Video (743/744)	High-density 15-pin to EVC connector
HP A4167A	Video (GSC card)	Standard 15-pin to EVC connector

### **Model 743 and Model 744 Functional Description**

This section describes the major components of the Model 743 and Model 744 VME board computers

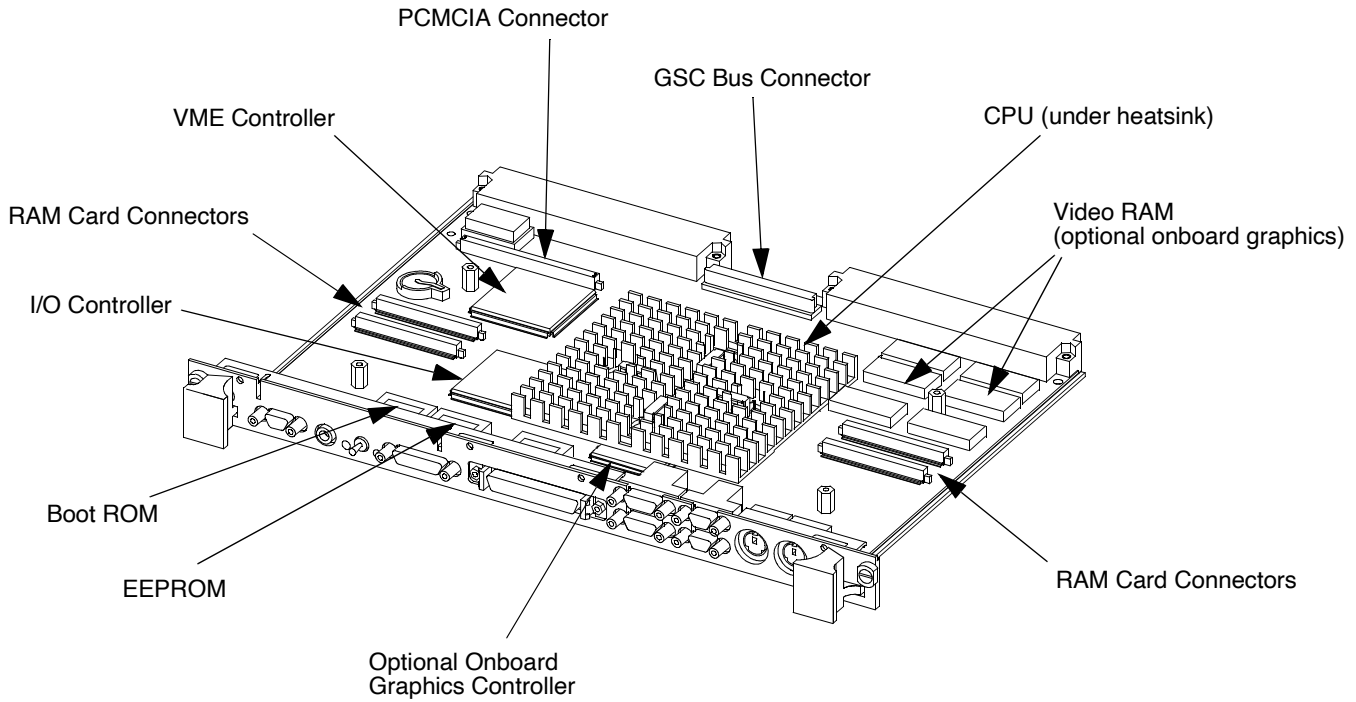
The system board contains the following functionality:

- Boot ROMs
- CPU
- Graphics
- I/O controller, which controls these interface circuits:
  - Audio
  - HP Parallel
  - LAN
  - RS-232-C
  - SE SCSI
  - Keyboard and mouse
  - Battery-backed Real Time/Time-of-Day clock
- Memory controller

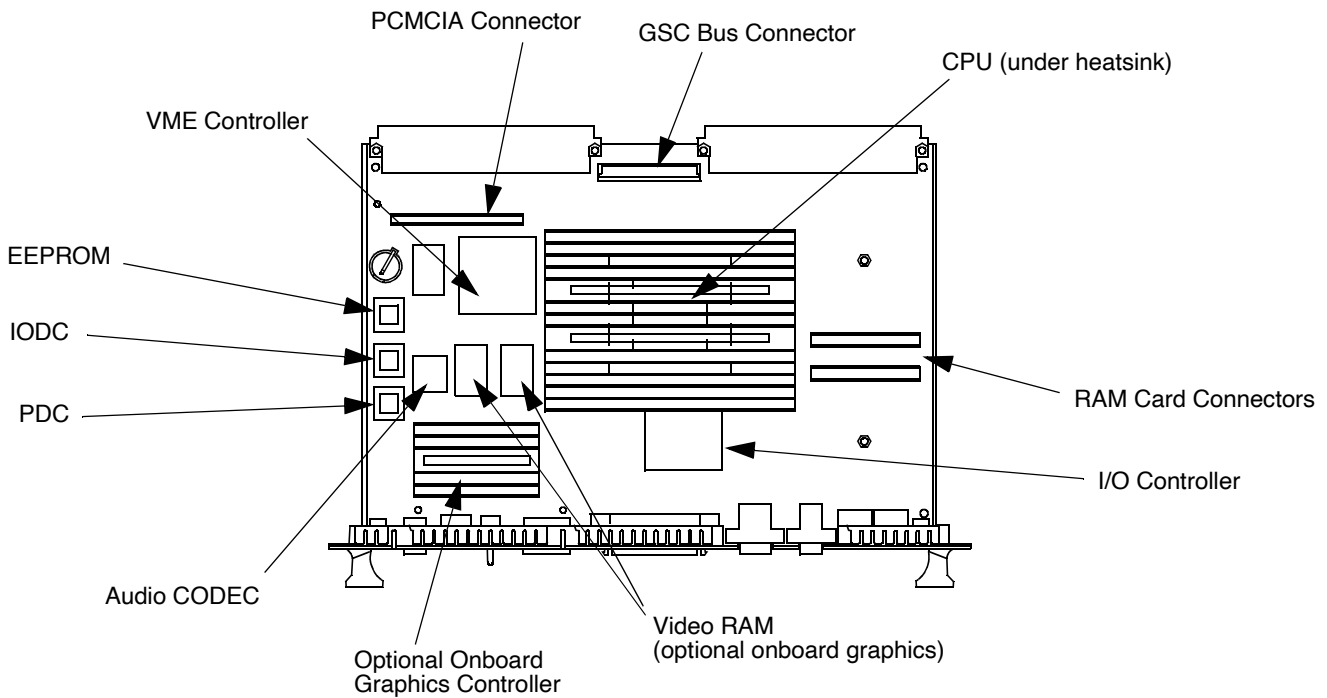
Figure 1-2 shows the major components of the Model 743.

Figure 1-3 shows the major components of the Model 744.

General Information  
**Model 743 and Model 744 VME Board Computers**

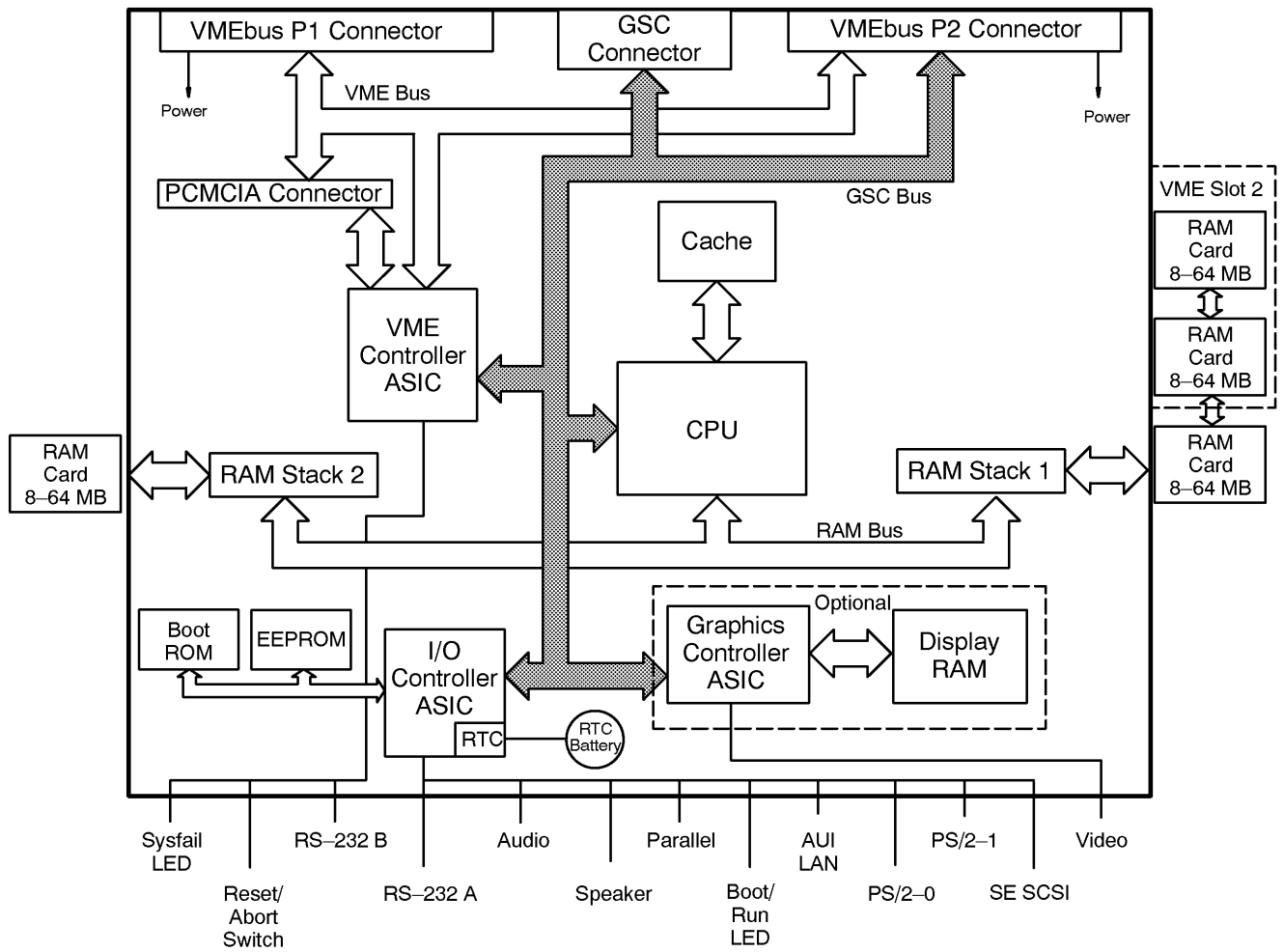


**Figure 1-2 Model 743 VME Board Computer Functional Components**



**Figure 1-3 Model 744 VME Board Computer Functional Components**

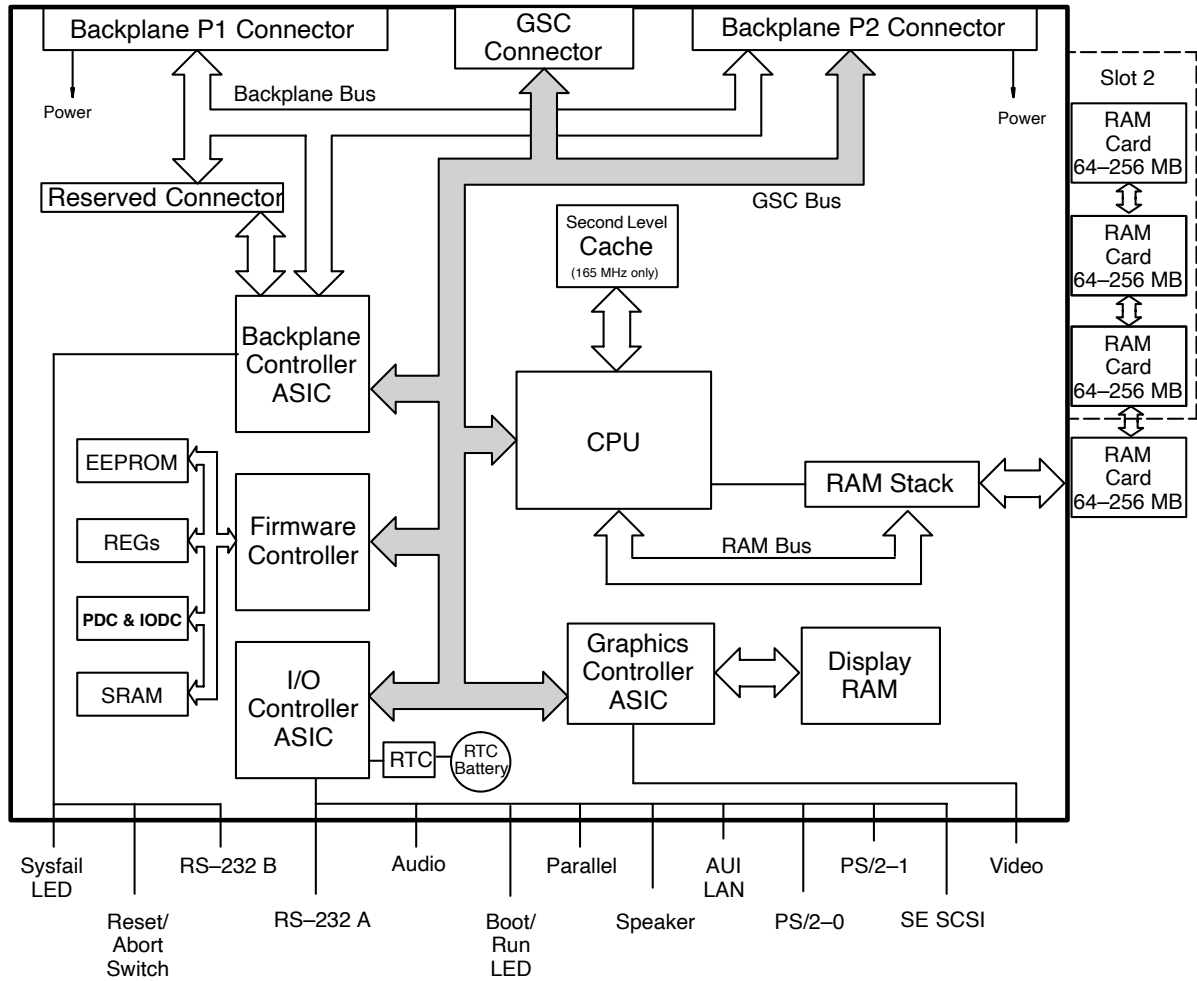
Figure 1-4 illustrates the functional architecture of the Model 743 system board.



**Figure 1-4 Model 743 Functional Block Diagram**

**Model 744 Block Diagram**

Figure 1-5 illustrates the functional architecture of the Model 744 system board.



**Figure 1-5 Model 744 Functional Block Diagram**

**CPU Circuit**

The Model 743 uses a Hewlett-Packard PA-RISC 7100-LC CPU chip and the Model 744 uses a Hewlett-Packard PA-RISC PA7300-LC CPU chip. The CPU chip is the heart of the CPU circuit. It executes instructions and controls the other circuits.

Table 1-7 lists the CPU performance figures of the Model 743 with HP-UX and Table 1-7 lists the CPU performance figures for the Model 744 with HP-UX.

**Table 1-7 Model 743 CPU Performance**

Model	743i/64		743i/100	
	9.05	10.x	9.05	10.x
MFLOPS (DP)	25.3	22.2	37.8	34.3
MIPS	77.7		121.6	121.8
SPECfp92	96.5	97.05	137.0	138.3
SPECint92	66.6	81.1	100.1	115.0
SPECfp95		2.6		3.47
SPECint95		1.9		2.89

**Table 1-8 Model 744 CPU Performance**

Model 744 Performance Based on HP-UX 10.20	132 MHz	165 MHz
SPECint95	5.90	7.90
SPECfp95	6.22	7.64

**Boot ROM Circuit**

The Boot ROM circuits have Boot ROMs containing 2x526 Kilobytes (Model 744) or 512 Kilobytes (Model 743) of information that does the following:

- Manages the internal interface configurations
- Searches for and boots an operating system
- Self-tests the board computer's main circuits
- Starts the CPU functions

An EEPROM stores the following information:

- Internal interface configurations
- LAN ID number
- System board serial number

**NOTE:**

The workstation's LAN ID number's last 6 characters are labeled on the EEPROM. The first group of six digits are typically “080009” or “0060b0” (the HP-owned prefix).

A PLL Clock Module generates the system clock, on which all timing is based.

**Graphics Circuit**

System boards with on-board graphics or graphics cards have a graphics controller ASIC and the display RAM. Resolution and refresh rate can be configured using the boot console handler for several types of monitors.

A keyboard must be connected to the PS/2 0 port if graphics are used as part of the console path. When a graphics device is specified as the console path, the boot ROM first checks for a keyboard by using the keyboard search list. If a keyboard is not found in this search list, graphics are not enabled.

Table 1-9 summarizes the graphics performance figures for the Model 743 with HP-UX and Table 1-9 summarizes the graphics performance figures for the Model 744 with HP-UX.

**Table 1-9 Model 743 Graphics Performance**

	Model 743 i/64		Model 743 i/100	
	8 Plane	HCRX 8 and 24	8 Plane	HCRX 8 and 24
2D/3D vectors/sec	1.4M	1.5M	1.6M	2.3M
Lighted, shaded quadrilateral/sec	15K	14K	23K	23K
PLBsurf	19	21	23	32
Triangles/sec	26K	25K	40K	40K
X11 Vec/sec	1.2M	1.5M	1.2M	2.1M
Xmark93	8.1	9.3	8.6	12.1



**Table 1-10 Model 744 Graphics Performance**

<b>On-board HP Visualize-EG Graphics</b>	<b>132 MHz</b>	<b>165 MHz</b>
X11 Lines	5.74M	TBD
Xmark93	33.11	36.47
PLBsurf93	49.7	TBD
PLB wire93	116.1K	135.4K
2D/3D vectors/sec	3.1M	TBD

**Model 743 Memory Controller Circuit**

The CPU's memory controller circuit manages memory. Up to 256 MB of RAM may be installed. An Error Checking and Correcting (ECC) function checks memory word read/write operations. The ECC function detects single-bit and double-bit errors. Single-bit errors are corrected. Double-bit errors are detected but not corrected. The memory controller circuit uses a 64-bit memory bus. The following two RAM card locations are used:

- RAM stack 1, behind the PS/2 connectors on the system board. Up to three RAM cards are supported.

Physical RAM slot positions are:

Bottom RAM card, slot 0

Middle RAM card, slot 1

Top RAM card, slot 2

- RAM stack 2, behind the audio connectors on the system board. One RAM card is supported and is in physical RAM slot 3.

**Model 744 Memory Controller Circuit**

The CPU's memory controller circuit manages memory. Up to 1 GB of RAM may be installed. An Error Checking and Correcting (ECC) function checks memory word read/write operations. The ECC function detects single-bit and double-bit errors. Single-bit errors are corrected. Double-bit errors are detected but not corrected. The memory controller circuit uses a 132-bit memory bus. One RAM card location is used, behind the PS/2 connectors on the system board. Up to four RAM cards are supported.

Physical RAM slot positions are:

Bottom RAM card, slot 0

Second RAM card, slot 1

Third RAM card, slot 2

Fourth RAM card, slot 3

**RAM Cards** When mixing RAM cards of different capacities that include 128 MB and 256 MB cards, the 128 MB and 256 MB cards must be installed into the lowest numbered memory sites. Memory mapping at turn on determines the size of the card in each location.

**LED Displays**

Model 743 and 744 VME Board Computers have two LEDs that indicate various system functions: a system failure LED and a functional LED. See Table 1-11.

**Table 1-11**

**LED Meanings**

<b>SYSFAIL (Red)</b>	<b>POWER (Green)</b>	<b>Meaning</b>	<b>Possible Solution</b>
Off	Off	No Power	Check for board seating in chassis.
On	2Hz Flash	Normal Power-on/self-test	
On	Off	Memory Failure	Troubleshoot for failed RAM card or problem with the RAM connection.
On	1 Flash/sec.	CPU (board) Failure	Replace the system board.
On	4 Flash/sec.	No console identified	Check the console search path and keyboard connections. If no problem is found, replace the system board.
On	On	OS is booted with VME services failure	Check the Operating System VME services. Check that VME services is configured in the kernel.
Off	On	OS is booted with VME services OK	

**I/O Controller ASIC**

I/O control by the system board's I/O controller ASIC includes the following interfaces:

- Audio
- AUI LAN
- HP Parallel
- PS/2 Ports 0 and 1
- RS-232 Port A
- Single-Ended SCSI
- Speaker

The battery-backed real-time clock is also implemented in the I/O controller ASIC.

The connectors for the system board's built-in interfaces are on the front panel. Most use micro-miniature connectors that require special conversion cables in order to use standard interface cables.

Table 1-12 summarizes I/O performance figures for the Model 743.

**Table 1-12**

**Model 743 I/O Performance**

I/O Type	Performance	Notes
Audio *	48 KHz	Sampling rate
FW SCSI *	10 MB/second	Asynchronous
	20 MB/second	Synchronous
GSC	32 MHz	64 MHz clock frequency
	33 <sup>1</sup> / <sub>3</sub> MHz	100 MHz clock frequency
HP Parallel	300+ KB/second	With DMA
	200 KB/second	Sustained
LAN	10 Mb/second	
PS/2	2.5 K 11-bit samples/sec	
RS-232	460.8 Kbps	
SE SCSI	5 MB/second	Synchronous
	1.5 MB/second	Asynchronous
* Not supported in HP-RT		

Table 1-13 summarizes I/O performance figures for the Model 744

**Table 1-13**

**Model 744 I/O Performance**

I/O Type	Performance	Notes
Audio *	48 KHz	Sampling rate
FW SCSI *	10 MB/second	Asynchronous
	20 MB/second	Synchronous
GSC	33 MHz	132 or 165 MHz clock frequency
HP Parallel	300+ KB/second	With DMA
	200 KB/second	Sustained
LAN	10 Mb/second	
PS/2	2.5 K 11-bit samples/sec	
RS-232	460.8 Kbps	
SE SCSI	5 MB/second	Synchronous
	1.5 MB/second	Asynchronous
* Not supported in HP-RT		

## General Information

### Model 743 and Model 744 VME Board Computers

The sections that follow explain the functions of the interfaces.

**Audio** Model 743 and Model 744 Board Computers provide compact disc-quality audio input and output, in stereo, with a 16-bit coder-decoder (CODEC) over a frequency range of 25-20,000 Hz. A stereo headphone mini-plug (8 ohms impedance) provides output. The stereo line-in and mono microphone mini-plugs provide input with the HP A4302A Audio Cable.

The CODEC combines CD quality stereo A/D converters for microphone and line input levels. D/A converters for driving headset and line outputs are used. The input sampling rate and format are programmable, as are the input gain control (used for software control of recording levels) and output attenuation.

A 1/8-inch mini-jack is used for the speaker out connection. The other audio signals are on a 9-pin micro D-sub connector. The output is capable of driving a minimum of 8 ohms. It can also be used for higher impedance devices with little or no additional distortion.

A voice-quality audio output may be used.

For information on programming for audio, refer to *Using the Audio Developer's Kit* (B2355-90069) and the man page *audio*.

Table 1-14 lists the Model 743 and Model 744 audio specifications.

**Table 1-14**

**Model 743 and Model 744 Audio Specifications**

Function	Range
Headphone maximum output level	2.75 V pp at 50 ohms
Input sensitivity	Line in, 2.0 V pp at 47 K ohms microphone, 22 mV at 1 K ohm
Programmable input gain	0 to 22.5 dB in 1.5 dB steps
Programmable output attenuation	0 to 96 dB in 1.5 dB steps
Programmable rates	8, 11.025, 16, 22.05, 32, 44.1, 48 KHz
Signal to noise ratio	Headphone, 61 dB Line in, 61 dB Microphone, 57 dB

**NOTE:**

Audio CD ROMs cannot output to the audio out connector.

**AUI LAN** LAN circuits use the Ethernet/IEEE 802.3 standard interface. Only the Attachment Unit Interface (AUI) version is used; no BNC connector is provided for ThinLAN. The AUI connector enables connections to an external MAU using the HP A4303A adapter cable. Table 1-15 summarizes the LAN AUI interface specifications.

**Table 1-15 LAN AUI Specifications**

Connector type	15-pin MDSM
Controller	Intel 82596CA compatible megacell
Data rate	10 Mbits/sec
Electrical interface	AUI
Type	IEEE 802.3, Ethernet 1.0

**Single-Ended SCSI** The 8-bit single-ended implementation is compatible with the current Series 700 products and supports 5 MB/sec data transfer rates.

The SCSI bus is terminated to 3.3 volts through 127 ohms on the system board. If the board computer is used in a VME chassis having internal mass storage devices, all devices except the last one must have their terminator removed. If an external disk drive is used, an active terminator must be used on the last drive's uncabled connector.

Table 1-16 summarizes the specifications for the single-ended SCSI interface.

**Table 1-16 Single-Ended SCSI Interface Specifications**

Controller	NCR 53C710 compatible macrocell, Rev D
Connector type	SCSI-II, ALT-1 50-pin high-density thumbscrew
Data rate	Asynchronous, 1.5 MBs/second Synchronous, 5 MB/second
Device limits	7 internal and/or external devices plus the host controller <sup>a</sup>
Maximum external cable length	4 meters (13.1 feet)
Type	SCSI-II (ANSI X3.131-1986), 8-bit, single-ended

a. The board computer is the host controller.

**HP Parallel** The parallel port is compatible with Centronics standards, plus some additional features found in HP Series 700 workstations. It supports a bi-directional register model interface. An 8-bit parallel, synchronous interface is used.

A high-density micro D-sub connector is used for the HP Parallel interface. An HP A4300A adaptor cable is required to convert to standard PC compatible 25-pin female D-sub.

Table 1-17 summarizes the specifications for the HP parallel interface.

**Table 1-17 HP Parallel Interface Specifications**

Connector type	Female 25-pin micro D-sub
Data rate	>300 Kilobytes/second with DMA 200 Kilobytes/second sustained
Device limit	1
Type	Centronics® and BUSY handshakes

**PS/2 Ports 1 and 0** There are two PS/2 style serial ports: one PS/2 keyboard port and one PS/2 mouse port.

**RS-232** There are two serial interfaces. The I/O controller ASIC controls port A, and the VME controller ASIC controls port B. Each supports CTS/RTS hardware handshaking. An HP A4301A adaptor cable is required to convert it to a standard PC compatible, 9-pin male D-sub. The maximum baud rate listed in Table 1-18 is the hardware limit. Actual transfer rates depend upon the operating system and application load.

Table 1-18 summarizes the specifications for RS-232-C.

---

**NOTE:**

The RS-232 port B is not active until VME Services is up and running.

**Table 1-18 RS-232-C Interface Specifications**

Baud rate	50 to 460.8 Kb/second
Connector type	9-pin female micro D-sub
Controller	16550 UART compatible megacell
Parity	Odd, even, none, one, zero
Stop bits	1, 1.5, 2
Type	EIA RS-232-C, CCITT V.24/V.28
Word size	5 to 8 bits

**Battery-Backed Real-Time Clock** The battery-backed clock is implemented in the I/O controller ASIC. Once power is applied to the system board, the battery-backed clock time is read by the operating system only during system initialization. Once the operating system is booted, real time is kept by using the timer built into the CPU. The battery-backed real-time clock is updated by the operating system only when the user (“root” or “super-user”) explicitly requests it though the **date** command. The clock has a resolution of 1 second. The accuracy of the clock is within ±5 seconds every 24 hours when the operating temperature is from 0 to 55 Deg.C.

**VME Controller ASIC**

A VME controller ASIC, with the VME backplane it plugs into, manages the board computer's interface to the VMEbus. The VME controller ASIC also controls the RS-232 B port interface.

Table 1-19 shows the VME addressing capabilities and Table 1-20 shows data transfer capabilities of the VME controller ASIC.

**Table 1-19 VME Addressing Capabilities**

Function	Capabilities
DMA as master	A16, A24, A32 with programmable address modifiers
Location monitor	A16, A24, A32
Message FIFO as slave	A16, A24, A32
PA memory as slave	A24, A32
Processor as master	A16, A24, A32 with programmable address modifiers

**Table 1-20 VME Data Transfer Capabilities**

Function	Capabilities	Supported Transfer Type
DMA as master	D08	Only for first cycle/last cycle alignment
	D16	Block or non-block
	D32	
	D64	Block only
Message FIFO as slave	D08	O
	D16, D32	Non-block only, only D7-D0 are significant
PA memory as slave	D08	EO
	D16	Block
	D32	
	D64	
Processor as master	D08, D16, D32	Non-block only

The VME controller ASIC supports the following additional features:

- 16 deep by 1 byte message FIFO with interrupt on not empty
- 256  $\mu$ s arbitration timer
- Ability to generate interrupts on any one of IRQ1 to IRQ7; programmable IACK status/ID.
- Automatic slot 1 detect by way of sensing VME BGIN[3] at power up.
- DMA controller with programmable bus tenure
- Independent location monitor
- IRQ1 to IRQ7 interrupt handling individually programmable.
- Programmable BR0 to BR3 levels (processor and DMA programmed separately)
- Programmable bus error timer from 10  $\mu$ s to 1.28 ms
- Programmable request mode: ROR, RWD, RWD/Fair
- Reception of read-modify-write cycles (Software protocol must be enforced for processor accesses to insure mutual exclusivity.)
- Selective generation of read-modify-write cycles
- Slot 1 arbiter programmable for RR or PRI bus arbitration
- VME64 "lock" address modifier cycles

Table 1-21 summarizes VME performance. The values shown in this table reflect raw hardware speed and do not include software overhead or system overhead.

**Table 1-21 VME Performance in MB/sec**

	D32		MBLT	
	Read	Write	Read	Write
Master	10	12	38	44
Slave	9	13	33	38

**Interval Timers** Three interval timers are part of the VME controller ASIC. These timers provide interrupts on terminal count and interrupt and restart on terminal count capability.

Table 1-22 summarizes the specifications for the interval timer.

**Table 1-22 Interval Timer Specifications**

Resolution	Drift
Timer 1 length	32 bits, cascadeable into timer 2
Timer 2 length	16 bits, cascadeable into timer 3
Timer 3 length	16 bits

**Watchdog Timer** The VME controller ASIC also includes a watchdog timer used with the HP-RT operating system.



**I/O Expansion**

The Model 743 and Model 744 board computers are capable of accepting expansion adapters allowing greater functionality through expansion I/O cards. The PMC bridge adapter (for HP-UX systems only) occupies an additional VME slot directly above or adjacent to the board computer, and has two sites for industry standard +5V signalling PMC cards. The PMC expansion adapter occupies another VME slot adjacent to or above the PMC bridge adapter, and provides two additional sites for PMC cards. The GSC expansion adapter has two sites for GSC expansion cards, and occupies one VME slot adjacent to or above the board computer. The PMC adapters and the GSC adapter cannot function together.

HP provides three GSC solutions for expanded I/O:

- 8-plane color graphics controller
- FWD SCSI controller
- ATM network controller

**Fast, Wide, Differential SCSI (GSC) (HP-UX only)** The FWD 16-bit implementation supports 20 MB/sec data transfer rates.

The internal, removable, differential bus terminators allow the card to be located at either end or between the ends of a SCSI bus. The host SCSI ID for the port is set by the user by way of the 4-position address selector DIP-type switch.

By default, the FWD SCSI card terminates one end of the SCSI bus by using removable terminator resistors that are on the card. Remove these terminator resistors if the card is in the middle of the bus.

Table 1-23 summarizes the FWD SCSI interface specifications.

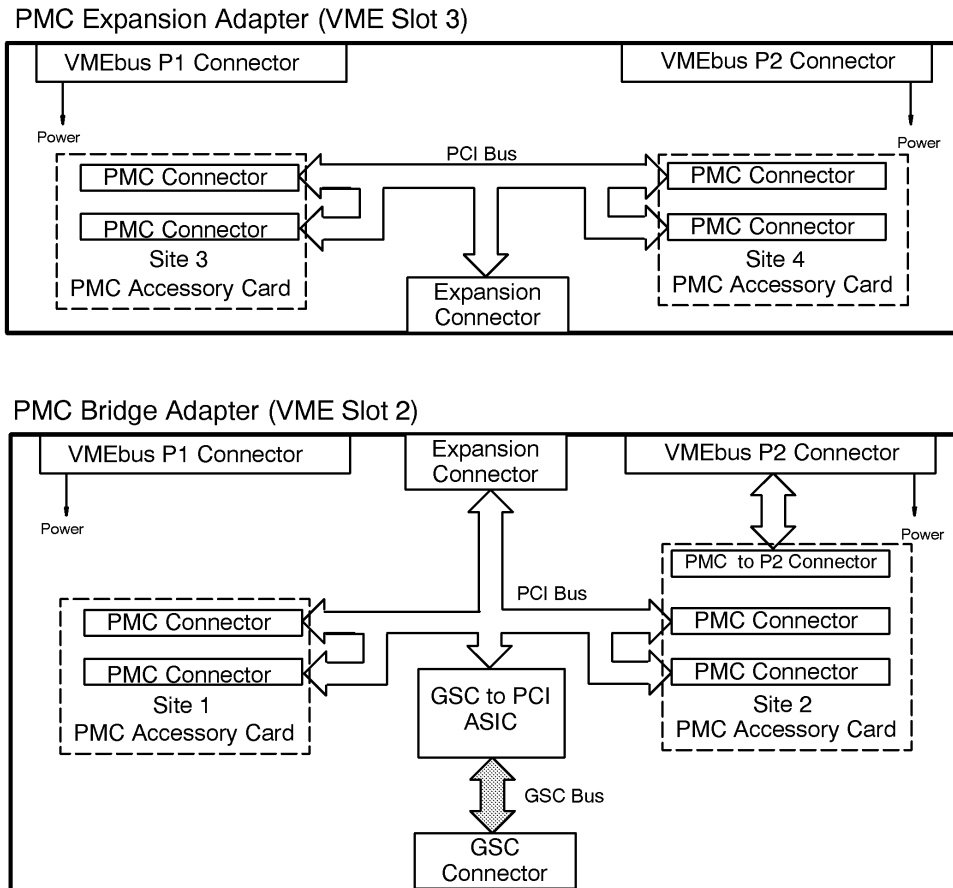
**Table 1-23**

**FWD SCSI Interface Specifications**

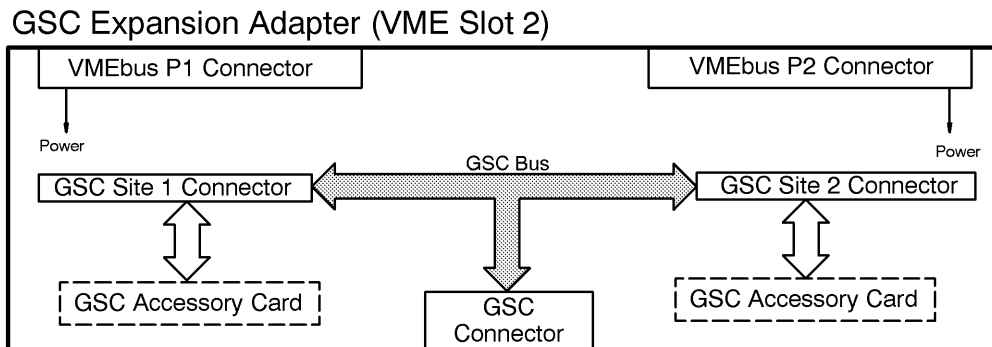
Connector type	SCSI-3, 68-pin high-density thumbscrew
Controller	NCR 53C720
Data rate	Asynchronous, 10 MB/second Synchronous, 20 MB/second
Device limits	15 internal and/or external devices
Maximum external cable length	25 meters (82 feet)
Type	SCSI-II, 16-bit

**I/O Expansion Block Diagrams**

Figure 1-6 illustrates the functional architecture of the PMC adapters, and Figure 1-7 illustrates the functional architecture of the GSC adapter.



**Figure 1-6** PMC Adapters Block Diagrams



**Figure 1-7** GSC Adapter Block Diagram

## Model 748 Ruggedized Workstation

The sections that follow contain the Model 748 Ruggedized Workstation product description and the Model 748 Ruggedized Workstation functional description.

### Product Description

Hewlett-Packard offers the following HP 9000 products:

- Model 748/132L Ruggedized Workstation
- Model 748/165L Ruggedized Workstation

The 748/132L and 748/165L model incorporates the HP 744/132L and HP 744/165L VME Board Computers that are based on the PA-RISC 7300LC central processing unit (CPU). All models provide a variety of interface, graphics, mass storage, and accessory card configurations. Table 1-24 summarizes the features of the Model 748.

**Table 1-24** Model 748 Ruggedized Workstation Features

Feature	Functionality
Operating system	HP-UX
System board	See the feature set for the Model 743 or 744 Board Computer
Monitors	17 or 19-inch color monitors 72 or 75 Hz refresh rate, multi-mode
Mass storage module	Up to four of the following devices: 4 GB or 9GB SE hard disk drive DDS-1, 2 GB native capacity yielding up to 4 GB w/Data compression. DDS-2, 4 GB native capacity yielding up to 8 GB w/Data compression. DDS-3, 12 GB native capacity, up to 24 GB w/Data compression 3.5-inch flexible disk drive CD-ROM drive
VME module	8 VME slots (six slots for VME add-in cards, two for board computer)
EISA module	4 EISA accessory cards
PCI module (option)	4 PCI accessory cards (PCI module replaces EISA module)
Power supply	Two 300 watt power supplies

### Supported Configurations

This section discusses the following supported configurations: mass storage, monitors, GSC mezzanine slot, built-in interfaces, EISA module, PCI module, and VME module.

**Mass Storage**

Model 748 uses several factory-installed mass storage devices. One or two removable media devices may be installed. Model 748 mass storage devices are factory installed with the removable media drives accessed from the front. Users may reconfigure devices to reverse the access. Hard disk drives are typically installed behind the removable media devices.

Mass storage devices are also available as the following upgrades:

- HP A4484A 4 GB SE SCSI Hard Drive Upgrade
- HP A5006A 9 GB SE SCSI Hard Drive Upgrade
- HP A2643A 2 - 4 GB DDS (DDS-1, 2 GB native, 4 GB with data compression) Tape Drive Upgrade
- HP A4307A 4-8 GB DDS (DDS-2, 4 GB native, 8 GB with data compression) Tape Drive Upgrade
- HP A4252A 12 - 24 GB DDS (DDS-3, 12 GB native, 24 GB with data compression) Tape Drive Upgrade
- HP A2645A 3.5-inch Flexible Disk Drive Upgrade
- HP A4496A Fast CD-ROM Disk Drive Upgrade

**Monitors**

Table 1-25 lists the monitors supported. Grayscale monitors are not supported.

**Table 1-25**

**Model 748 Supported Monitors**

Type	Resolution	Comments
17-inch color	1280 by 1024	
20-inch color	1280 by 1024	

**GSC Mezzanine Slot GSC**

Model 748 Ruggedized Workstations have a GSC Mezzanine slot.

**SCSI Interface** The mass storage module has a SCSI connector for connecting external SCSI device cables. When the external SCSI interface connector is not used, a SCSI terminator should be plugged into the SCSI connector.

A cable from the mass storage module connects to the system board's SCSI connector and must be connected for internal drives to operate. SCSI interface circuits use high-density, shielded connectors. The internal cable length is 1.8 meters (5.9 feet).

The last device on each SCSI bus must be terminated. Internal drives do not have terminators enabled. The SCSI bus terminator(s) shipped with the Model 748 must be installed on the external bus connector(s) if no external devices are connected. The single-ended terminator is part number A1658-62016, and the FWD terminator part number is A1658-63013.

**EISA Module** The Model 748 is available with a 4-slot EISA module. Table 1-26 shows the EISA accessory cards that are supported. In addition, the EISA module also supports the HP Human Interface Link (HP-HIL). However, HP-HIL devices are no longer offered by HP.

---

**NOTE:** Only one of the Human Interfaces (HP-HIL or PS/2) can be used at a time. Use of one interface excludes the other interface.

---

**Table 1-26 Supported EISA Accessory Cards**

Product Number	Product Name	Quantity Supported	Notes
HP 2070B	Instrument HP-IB	Up to 4	
HP 20711	High-Speed Instrument HP-IB	Up to 4	
	GPIO Interface Card	1	
HP 25525B	Differential SCSI	Up to 4	
HP 25560A	HP-IB Host Adaptor	1	
HP 25567B	IEEE 802.3 Thin/AUI LAN	Up to 4	
HP J2159A	PSI/X.25 Interface	Up to 4	
HP J2165A	Token Ring 802.5	Up to 4	
HP J2645AA	100VG-Any LAN	Up to 4	
HP J2802B	HP ATM Adapter Card	Up to 4	

**PCI Module** The Model 748 is available with a module that provides four slots for customer provided PCI accessory cards. The module supports the +5 Vdc PCI bus signalling card type.

**VME Module** A variety of VME accessory cards can be installed in the Model 748 's 8-slot VME module (slots 3 through 8 are for add-on cards). The slots conform to the 6U form factor. Slot numbers are 8 through 1, top to bottom. The VME backplane provides an interconnect connector for the EISA module.

---

**NOTE:** A Model 743 or 744 must be installed in VME **Slot 1** to provide VME Slot 1 controller functions (bus arbitration) for *any* VME boards installed in VME slots 3 through 8.

---

**Model 748 Ruggedized Workstation**

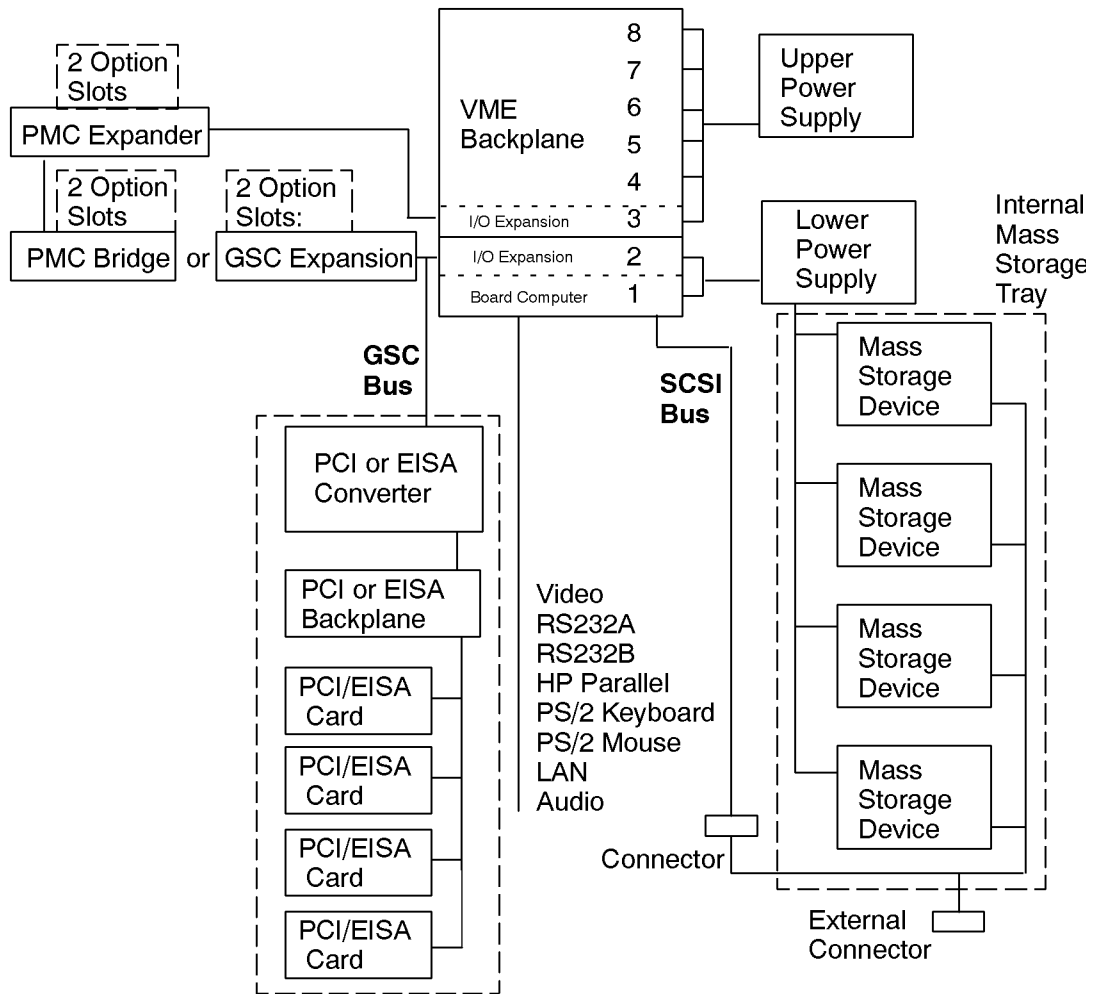
**Model 748 Ruggedized Workstation Functional Description**

The section that follows contains a block diagram of the Model 748 Ruggedized Workstation and describes EISA bus performance.

**EISA Bus Performance** The ideal slave read/write transfer rate is 25/25 MB/sec.

**Block Diagram**

Figure 1-8 shows the functional architecture of the Model 748 workstation.



**Figure 1-8 Model 748 Functional Block Diagram**

**Environmental Specifications for Monitors**

This section describes the environmental specifications for the HP D2806A, HP A4490D, and HP A4331A/D color monitors.

Table 1-27 lists the operating, non-operating or storage, and recommended specifications for altitude, humidity, and temperature for the monitors.

**Table 1-27 Environmental Specifications for Monitors**

<b>Environmental Condition</b>	<b>Specification</b>
Altitude, non-operating	15,240 m (49,530 ft.)
Altitude, operating	3,658 m (11,888 ft.) <sup>a</sup>
Humidity, nonoperating or storage	5% to 95% RH
Humidity, operating	10% to 80% RH
Humidity, recommended operating at 22 Deg C	Non-condensing RH
Temperature, nonoperating or storage	-40 Deg C to 60 Deg C
Temperature, operating	0 Deg C to 40 Deg C
Temperature, recommended operating	10 Deg C to 40 Deg C

a. Temperature derating above 2,500-m (8,000 ft.): 1.1 degrees C for each 1,000 feet above 7,500 feet.

## **Original Equipment Manufacturer (OEM) Support Overview**

The sections that follow describe standard OEM support and additional OEM support.

### **Standard Support**

OEMs may obtain the following standard hardware and software support through their local Hewlett-Packard Sales and Service Office:

- Customer support programs for servicing Hewlett-Packard products
- System/product hardware/software configurations
- System support options, including the following:
  - HP SupportLine electronic support
  - License to use software updates
  - Media and document updates
  - On-site response

### **Additional OEM Support Programs**

Contact your Hewlett-Packard OEM Sales Representative regarding the availability of the following OEM support:

- Detailed product qualification programs information
- Drawings: electrical and mechanical
- Engineering consulting time
- Hewlett-Packard specifications for products
- Peripheral device specifications
- Product component lists and specifications



---

## **References**

This chapter lists the titles and part numbers for hardware and software manuals associated with the Model 743/744 and Model 748.

### HP Hardware Manuals

This section contains tables listing the hardware installation guides, service manuals, and diagnostic manuals for the Model 743/744 and Model 748.

#### Installation Guides

Table 2-1 lists the hardware installation guides available for the Model 743 and Model 748.

**Table 2-1**

#### System Installation/Owner's Manuals

Manual Title	Part Number
HP Model 743 VMEbus Board Computer Owner's Guide	A2636-90603
HP Model 744 VMEbus Board Computer Owner's Guide	A4511-90606
HP Model 748 Workstation Owner's Guide	A4511-90604

#### Service Manuals

Table 2-2 lists the hardware service manuals available for the Model 743/744 and Model 748.

**Table 2-2**

#### Related Service Manuals

Manual Title	Part Number
HP Model 743 VMEbus Board Computer	A2636-90604
HP Model 748	A4511-90605
HP Model 744	A4511-90603

**Diagnostic Manuals**

Table 2-3 lists the hardware diagnostic manuals available for the Model 743/744 and Model 748.

**Table 2-3****Diagnostic Manuals**

<b>Manual Title</b>	<b>Part Number</b>
PA-RISC Support Tools Manual Licensed Users Volume 1, SPU	5960-3149
PA-RISC Support Tools Manual Licensed Users Volume 2, Device Adapters/MUXes	5960-3151
PA-RISC Support Tools Manual Licensed Users Volume 3, LAN	5960-3153
PA-RISC Support Tools Manual Licensed Users Volume 4, SCSI	5960-3155
PA-RISC Support Tools Manual Licensed Users Volume 5, Disks	5960-3157
PA-RISC Support Tools Manual Licensed Users Volume 6, Tapes/Printers	5960-3159
PA-RISC Support Tools Manual Licensed Users Volume 7, Utilities	5960-3161
PA-RISC Support Tools Manual Licensed Users Volume 8, ISL Support Tools	5960-3163
PA-RISC Support Tools Manual for HP Employees	5960-3165
Support Tools Manager User's Manual; HP 9000 Series 700 and 800	5961-1612
HP Apollo 9000 Series 700 Diagnostics Manual, Volume 1	09740-90041
HP Apollo 9000 Series 700 Diagnostics Manual, Volume 2	09740-90043
HP Apollo 9000 Series 700 Support Tape/CD-ROM User's Manual	B2380-90000

### HP Software Manuals

This section contains tables listing the software system usage manuals and development manuals for the Model 743/744 and Model 748.

Table 2-4 lists the software system usage manuals available for the Model 743/744 and Model 748.

**Table 2-4**      **System Usage Manuals**

Manual Title	Part Number
HP-RT System Administration Tasks	B5487-90002
VME Backplane Networking System Administration Guide	B5489-90001

Table 2-5 lists the software development manuals available for the Model 743/744 and Model 748.

**Table 2-5**      **Software Development Manuals**

Manual Title	Part Number
HP-UX 9.05 Device Drivers	A2636-90020
VME Services HP-UX 10	A4412-90022
Driver Writing in the HP-RT Environment	B5487-90003

---

## Quality

The Quality Chapter discusses safety compliance programs, electromagnetic compatibility programs, climatic and dynamic environmental tests, acoustics levels, statistical reliability, and manufacturing quality programs.

## Safety Compliance Programs

The sections that follow describe the Underwriter's Laboratories, Canadian Standards Association, and TUV Rheinland programs.

### Introduction

Models 743, 744, and 748 are designed, manufactured, and marketed in compliance with the published safety standards stated below. Validation testing was done with one unit representative of the product shipped to the customer. Continued compliance is measured by periodic regulatory audits; production units are tested for each audit. Models 743, 744, and 748 are in compliance with adopted safety standards issued by the following standards bodies:

- Underwriter's Laboratories (USA)
- Canadian Standards Association (Canada)
- TUV Rheinland (Germany)

The sections that follow explain each standard.

#### **Underwriter's Laboratories (USA)**

- UL Standard 1950 Information Technology Equipment

As evidence of UL's listing, the products are marked with the UL listing mark.

#### **Canadian Standards Association (Canada)**

- CSA Standard 22.2 No. 950 Safety of Information Technology Equipment including Electronic Business Equipment

As evidence of CSA's certification, the products are marked with the CSA monogram.

#### **TUV Rheinland (Germany)**

- Standards:
  - Safety - EN60950 Safety of Information Technology Equipment including Electronic Business Equipment; International Electrotechnical Commission, Publication 950
  - Ergonomics - ZH1/618 Safety Regulations for Display Work Places in the Office Sector

As evidence of TUV's certification, the products are marked with the TUV GS mark.

## Electromagnetic Compatibility Programs

The sections that follow discuss the Federal Communications Commission, European Community, and Voluntary Control Council for Interface standards bodies.

### Introduction

Models 743, 744 and 748 comply with published standards for Electromagnetic Compatibility (EMC). In general, testing to required standards was performed using statistically significant quantities of typical Models 743, 744 and 748 configurations representative of the product shipped to customers. These tests' statistical basis demonstrates that with 80% confidence, at least 80% of the production population meets the specified margins to each standard. Additional configurations are also tested to reduce the probability that non-conforming configurations exist. Continued compliance is measured by periodic regulatory audits; production units are tested for each audit. The Models 743, 744 and 748 are in compliance with adopted EMC standards issued by the following standards bodies:

- Federal Communications Commission (USA)
- European Community
- Voluntary Control Council for Interference (Japan)

### Federal Communications Commission (USA)

- Compliance Date: 6 November 1992 (dates of subsequent revisions available upon request)
- Self-Certified to 47 CFR (Code of Federal Regulations), parts 2 and 15, Class A

As evidence of compliance, products are marked with the FCC A statement.

### European Community

- Compliance Date: 6 November 1992 (dates of subsequent revisions available upon request)
- Compliant to the EMC Directive 89/33/EEC and 92/31/EEC for Information Technology Equipment (ITE) per EN55022, and for Industrial, Scientific, and Medical Equipment (ISM) per EN55011

As evidence of compliance, products are marked with the CE mark, and the product manuals include a Declaration of Conformity.

### Voluntary Control Council for Interference (Japan)

- Compliance Date: 9 December, 1992. (dates of subsequent revisions available upon request)
- Registered to VCCI as a Class A product, according to CISPR 22

As evidence of compliance, products are marked with the VCCI statement.

**Overview**

The sections that follow summarize the Electromagnetic Compatibility Programs. The following is a list of those programs:

- 1 Electromagnetic field emissions test suite
  - Radiated emissions (Table 3-1)
  - Conducted emissions (Table 3-2)
  - Magnetic emissions (Table 3-3 and Table 3-4)
- 2 Electromagnetic field immunity/susceptibility test suite
  - Electro-Static discharge field immunity (Table 3-5)
  - Radiated field immunity (Table 3-6)
  - Magnetic field immunity (Table 3-7)
- 3 Line transients immunity/susceptibility test suite
  - Electrical fast transients (Table 3-8)
  - Surge transients (Table 3-9)
  - Conducted immunity (Table 3-10)
  - Line sag (Table 3-11) Line surge (Table 3-12)
  - Line blackout/dropout (Table 3-13)
  - Line brownout (Table 3-14)
  - Line brownout/recovery (Table 3-15)

**Electromagnetic Field Emissions Test Suite**

This section summarizes the Electromagnetic Field Emissions Test Suite.

Table 3-1 summarizes the radiated emissions tests during operation.

**Table 3-1**

**Radiated Emissions Tests During Operation**

Standard	Level
EN55011 (ISM)	CISPR 11 class A
EN55022 (ITE)	CISPR 22 class A
FCC CFR 47 parts 2 and 15	FCC Class A
VCCI class A	CISPR 22 class A

Table 3-2 summarizes the conducted emissions tests during operation.

**Table 3-2**

**Conducted Emissions Tests During Operation**

Standard	Level
EN55011 (ISM)	CISPR 11 class A
EN55022 (ITE)	CISPR 22 class A



**Table 3-2 Conducted Emissions Tests During Operation**

Standard	Level
FCC CFR 47 parts 2 and 15	FCC Class A
VCCI class A	CISPR 22 class A

Table 3-3 summarizes the magnetic emissions tests while the equipment is not operating.

**Table 3-3 Magnetic Emissions Tests While Non-Operating**

Standard	Level
HP Standard 765.006 complies with CFR49 IATA Dangerous Goods Regulations, 30ed	<2 milligauss at 2.1 m

Table 3-4 summarizes the magnetic emissions tests during operation.

**Table 3-4 Magnetic Emissions Tests During Operation**

Standard	Level
HP Standard 765.007	< 5 gauss p-p

**Electromagnetic Field Immunity/Susceptibility Test Suite**

This section summarizes the Field Immunity/Susceptibility Test Suite.

**NOTE:** All tests in this suite were performed while the product was operating.

Table 3-5 summarizes the electro-static discharge field immunity tests.

**Table 3-5 Electro-Static Discharge Field Immunity**

Standard	Level
HP Standard 765.002	15 KV A.D. (operating)
IEC 801-2 level 2	4 KV C.D., 8 KV A.D.
prEN50082-2	(ISM) 4 KV C.D., 8 KV A.D.
prEN55024-2	(ITE) 3 KV C.D., 8 KV A.D.

Table 3-6 summarizes the radiated field immunity test.

**Table 3-6 Radiated Field Immunity**

Standard	Level
prEN55024-3 (ITE/ISM)	3 V/m (IEC 801-3 level2)

Quality  
Electromagnetic Compatibility Programs

Table 3-7 summarizes the magnetic field immunity tests.

**Table 3-7**      **Magnetic Field Immunity**

Standard	Level
HP Standard 765.001	317 A/m
IEC 801-8 level 5	100 A/m

**Line Transients Immunity/Susceptibility Test Suite**

This section summarizes the Line Transients Immunity/Susceptibility Test Suite.

---

**NOTE:** All tests in this suite were performed while the product was operating.

---

Table 3-8 summarizes the electrical fast transients test.

**Table 3-8**      **Electrical Fast Transients**

Standard	Level
prEN55024-4 (ISM)	2 KV mains, 1 KV I/O ports

Table 3-9 summarizes the surge transients tests.

**Table 3-9**      **Surge Transients**

Standard	Level
HP Standard 765.003	1 KV DM/CM high energy transient
HP Standard 765.003	1 KV DM/CM low energy transient
HP Standard 765.003	3 KV peak DM/CM low energy ring wave
IEC 801-5 level 3	1 KV DM, 2KV CM

Table 3-10 summarizes the conducted immunity test.

**Table 3-10**      **Conducted Immunity**

Standard	Level
EN55082-1, IEC801-6, level 2	3 V rms

Table 3-11 summarizes the line sag test.

**Table 3-11**      **Line Sag**

Standard	Level
HP Standard 765.003	500 ms, 33% sag

Table 3-12 summarizes the line surge test.

**Table 3-12**      **Line Surge**

Standard	Level
HP Standard 765.003	500 ms, 25% surge

Table 3-13 summarizes the line blackout/dropout test.

**Table 3-13**      **Line Blackout/Dropout**

Standard	Level
HP Standard 765.003	20 ms

Table 3-14 summarizes the line brownout test.

**Table 3-14**      **Line Brownout**

Standard	Level
HP Standard 765.003	Minimum rated line voltage to 0 V in 30 minutes.

Table 3-15 summarizes line brownout/recovery test.

**Table 3-15**      **Line Brownout/Recovery**

Standard	Level
HP Standard 765.003	0 V to minimum rated line voltage in 30 minutes.

## Climatic and Dynamic Environmental Ruggedness

The sections that follow summarize the climatic and dynamic environmental tests suites.

### Introduction

Models 743, 744 and 748 are designed for use in an environment that involves moderately high and low temperatures, humidity variations, and occasional vibration. Many of the test limits the workstations are subjected to during development are more severe than those documented.

The tests were developed to cause product failure so that product weaknesses are identified, understood, and eliminated, when possible and to provide greater assurance of long-term compliance to product specifications.

An effective qualification program establishes appropriate assurances. Our development and manufacturing process capabilities are well understood.

Significant quantities of Models 743, 744, and 748 were tested prior to release for volume production. Representative samples of customer-shippable workstations were tested in various configurations through the environmental tests to evaluate corner-case conditions.

---

**NOTE:**

---

Presentation of these test suites does not imply a guarantee of product performance, nor a guarantee of performance to these levels by the entire population of Models 743, 744, and 748 computer systems.

### Overview

The following is a list of the climatic and environmental ruggedness tests suites summarized in this section:

- 1 Temperature, humidity, and altitude test suite
  - Temperature (Table 3-16 and Table 3-17)
  - Humidity (Table 3-18 and Table 3-19)
  - Altitude (Table 3-20 and Table 3-21)
- 2 Vibration and shock test suite
  - Vibration (Table 3-22)
  - Shock (Table 3-23 and Table 3-24)

**Temperature, Humidity, and Altitude Test Suite**

Table 3-16 and Table 3-17 summarize the temperature tests suite.

**Table 3-16 Temperature Tests While Non-Operations**

Standard	Level
HP class B1 (IEC 654 Part 1 class C3 compatible)	-40 Deg C to 71 Deg C (-40 Deg F to 159.8 Deg F)

**Table 3-17 Temperature Tests During Operation**

Standard	Level
HP class B1 (IEC 654-1 class Bx compatible)	0 Deg C to 55 Deg C (41 Deg F to 131 Deg F)
Temperature slew rate (exceeds IEC 654-1)	10 Deg C/minute (50 Deg F/minute)

Table 3-18 and Table 3-19 summarize the humidity tests suite.

**Table 3-18 Humidity Tests While Non-Operational**

Standard	Level
HP class B	90% relative humidity at 65 Deg C

**Table 3-19 Humidity Tests During Operation**

Standard	Level
Condensation	<5 minutes recovery
HP class B	15% to 95% relative humidity at 40 Deg C

Table 3-20 and Table 3-21 summarize the altitude test suite.

**Table 3-20 Altitude Tests While Non-Operating**

Standard	Level
HP Standard 761 (class B) (exceeds IEC 654-1)	4.6 Km (15 Kft)

**Table 3-21 Altitude Tests During Operation**

Standard	Level
HP Standard 761 (class B) (exceeds IEC 654-1)	4.6 Km (15 Kft)

Quality  
**Climatic and Dynamic Environmental Ruggedness**

Table 3-22 summarizes the vibration tests suite.

**Table 3-22**      **Vibration Tests While Non-Operating**

Standard	Level
HP Standard 759 (class B1)(exceeds IEC 654-3/VH2)	7.4 m/s <sup>2</sup> (0.75 g 0-p) swept sine
Packaging tests HP Standard 762	4.9 m/s <sup>2</sup> (0.5 g 0-p) swept sine
Packaging tests HP Standard 762	0.015 g <sup>2</sup> /Hz (.3 g rms) random

Table 3-23 and Table 3-24 summarizes the shock tests suite.

**Table 3-23**      **Shock Tests While Non-Operational**

Standard	Level
Bump test HP Standard 760 (class B)	> 294 m/s <sup>2</sup> (>30g) trapezoidal wave
Packaging drop test HP Standard 762 IEC 654-3	.61 meters (24 inches)

**Table 3-24**      **Shock Tests During Operation**

Standard	Level
HP Standard 760 (class B), IEC 654-3	150 cm/s < 3ms 1/2 half sine

---

## Acoustics

This section summarizes the sound power level test suite.

### Sound Power Levels

Table 3-25 summarizes the sound power level test suite. Sound power levels are A-weighted for these tests.

**Table 3-25**

### Sound Power Levels

Standard	Level	Equipment Under Test Conditions, Procedures, and Measurements (Acceptance Criteria)
HP Environmental tests, Section 767	Model 748: 6.22 Bels	Fan(s) operating at high speed.
	Model 748: 5.72 Bels	Fan(s) operating at low speed.

## Statistical Reliability

The sections that follow explain the Annualized Failure Rate (AFR) and the Mean Time Between Failure (MTBF) computations.

### Annualized Failure Rate Projections

Estimated AFR is based on a parts count and the failure rates of those parts in similar products. The AFR is estimated from the sum of the failure rates of the components' assemblies. A key assumption is that AFR is constant beyond the early life of the product and before long-term wear out.

Projected Failure Rate is the mature AFR, estimated from the failure rates of the components of the product. The "Estimated Long-Term Annualized Failure Rate" is a future projection of an average realistic failure rate beyond the typical infant failure period that occurs in the first few months of use and before long-term wear out, which occurs after many years of use.

### Mean Time Between Failure Computations

The MTBF is the reciprocal of the AFR. MTBF uses the following two units of time:

- Annualized MTBF (A-MTBF), the time units are years, or annually.
- Hourly MTBF (H-MTBF), the time unit is the hour.

This is derived by factoring out the AFR's annualized percentage, then finding its reciprocal. A resultant A-MTBF term is in years.

**Table 3-26**      **MTBF Example**

Example	AFR
Model 744 VME board computer with graphics	4.8%/year
Add one 32MB RAM card	0.72%/year
Total	5.5%/year

$$\frac{1}{0.055 / 8766 \text{ hours}} = 159,381 \text{ hours}$$



The H-MTBF numbers in the following tables are rounded to the nearest 100 hours.

**Table 3-27 Model 748 Ruggedized Workstation With Model 743 CPU AFR Projections (%/Year)**

Hardware Configurations	Projected AFR (%/Yr.)
743 VME Board Computer, 32 MB RAM (two 16 MB cards), no on-board graphics	11.5
Option 64 MB RAM card (one card using 16 Mbit DRAM)	1.5
8-Plane Color Graphics (GSC mezzanine card)	1.7

**Table 3-28 Model 748 Ruggedized Workstation With Model 744 CPU AFR Projections (%/Year)**

Hardware Configurations	Projected AFR (%/Yr.)
744 VME Board Computer, 32 MB RAM, EISA Tray, 2.0-GB FWD SCSI Disk, 17-inch Monitor	11.8
Option 64 MB RAM card (one card using 16 Mbit DRAM)	1.23
HCRX 8-Plane Graphics	1.38

**Table 3-29 Model 743 VME Board Computer AFR Projections (%/Year)**

Hardware Configurations	Projected AFR (%/Yr.)
743 VME Board Computer, no graphics	3.1
743 VME Board Computer, and on-board 8-plane color graphics	3.8
Memory 8 MB RAM card (one card using 4 Mbit DRAM)	0.6
16 MB RAM card (one card using 4 Mbit DRAM)	1.2
32 MB RAM card (one card using 16Mbit DRAM)	0.7
64 MB RAM card (one card using 16Mbit DRAM)	1.5
Option 8-Plane Color Graphics (GSC mezzanine card)	1.7
HCRX-8	1.38
HCRX-24	1.54
ATM	2.0
PMC Bridge	2.0
PMC Bridge and Expander	3.0

**Table 3-30 Model 744 VME Board Computer AFR Projections (%/Year)**

Hardware Configurations		Projected AFR (%/Yr.)
744 VME Board Computer with on-board graphics option		4.8
Memory	32 MB RAM card (one card using 16Mbit DRAM)	0.7
	64 MB RAM card (one card using 16Mbit DRAM)	1.23
	128 MB RAM card (one card using 64Mbit DRAM)	2.1
Option	8-Plane Color Graphics (GSC mezzanine card)	1.7
	HCRX-8	1.38
	HCRX-24	1.54
	ATM	2.0
	PMC Bridge	2.0
	PMC Bridge and Expander	3.0

Table 3-31 summarizes the MTBF for the Model 743.

**Table 3-31 Model 743 VME Board Computer MTBF (hr-MRBF) Computations**

Hardware (Includes Model 743 VME Board Computer)	No On-Board Graphics	On-Board Graphics
	MTBF (Hours)	MTBF (Hours)
16 MB RAM (one 16 MB card using 4 Mbit DRAM)	186,000	160,000
32 MB RAM (one 32 MB card using 16Mbit DRAM)	210,000	177,800
64 MB RAM (one 64 MB card using 16 Mbit DRAM)	173,900	153,800
128 MB RAM (two 64 MB cards using 16 Mbit DRAM)	131,100	117,600
256 MB RAM (four 64 MB cards using 16 Mbit DRAM)	87,900	81,600

---

## **Mechanical Information**

This chapter contains mechanical information about the components of the Model 743 and Model 744 VME Board Computers and the Model 748 Ruggedized Workstation. Included is air flow requirements, interface connector manufacturing data, system board and accessory card dimensions, chassis and module dimensions and weights, mounting and support, and mechanical drawings.

## Model 743 and Model 744 VME Board Computers

### Key Components

Figure 4-1 shows key components on the Model 743 VME Board Computer.

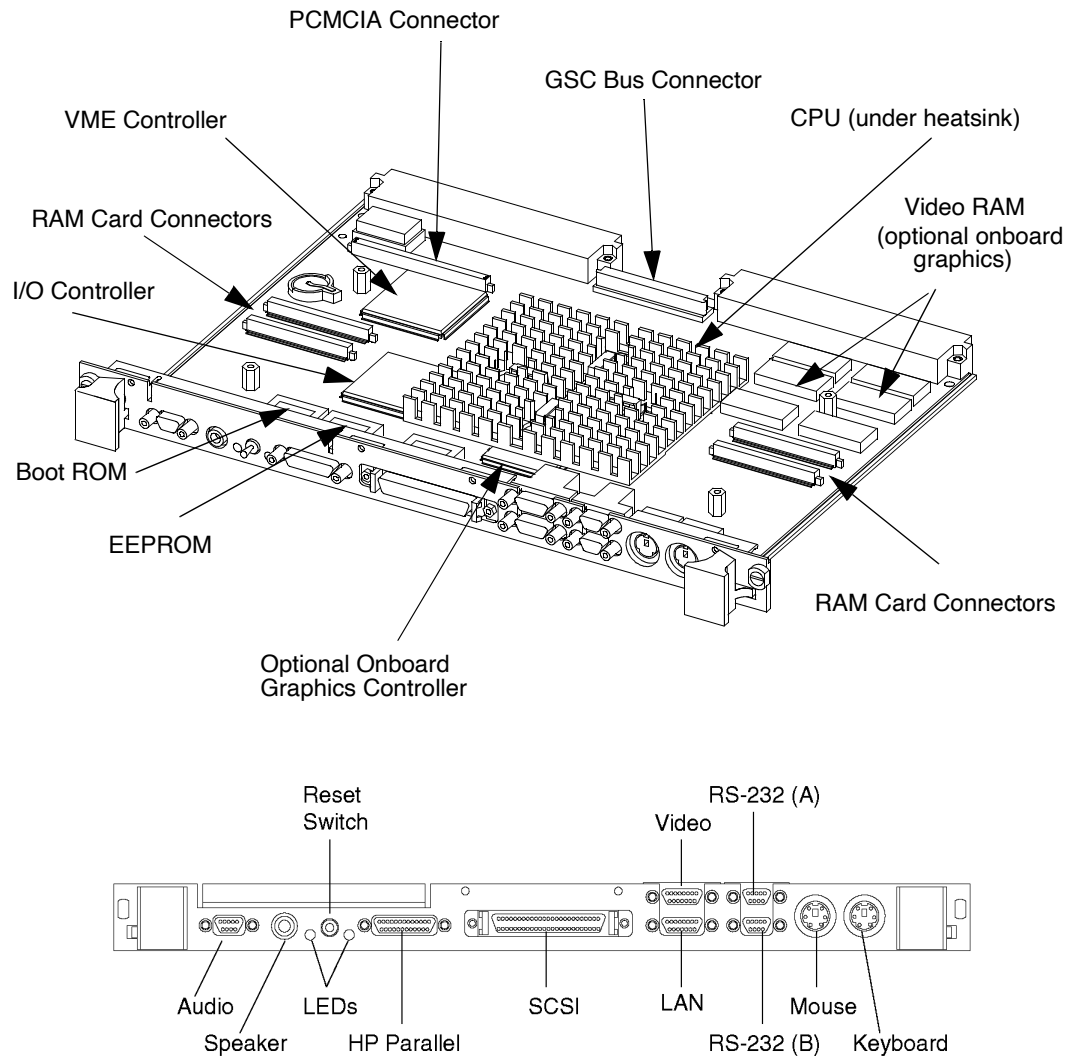
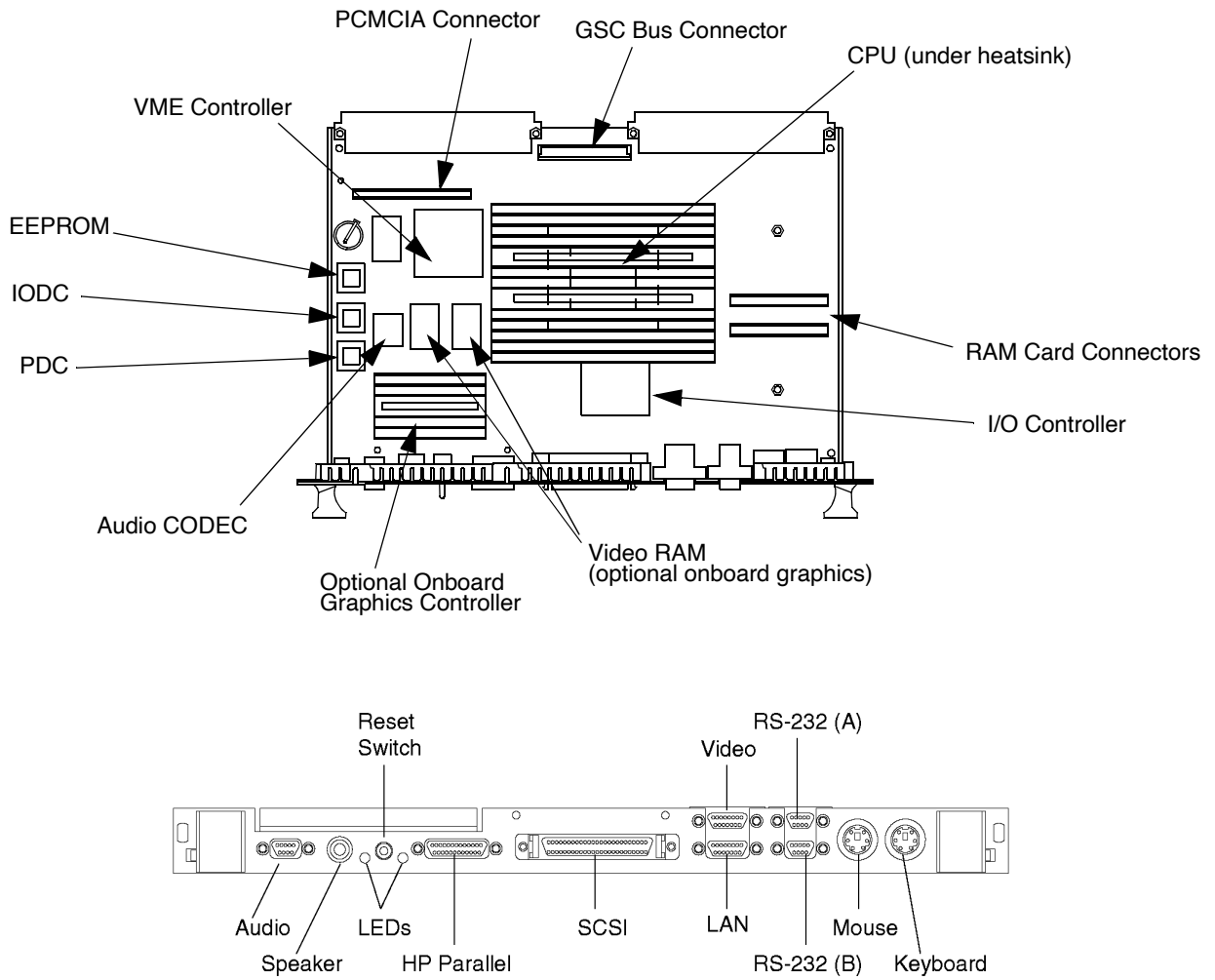


Figure 4-1 Model 743 Key Components

Figure 4-2 shows key components on the Model 744 VME Board Computer.



**Figure 4-2** Model 744 Key Components

### Air Flow Requirements

The air flow requirements for the Model 743 and Model 744 are as follows:

46 linear meters (150 linear feet) per minute, -5 Deg C to 35 Deg C (23 Deg F to 95 Deg F)

61 linear meters (200 linear feet) per minute, 35 Deg C to 55 Deg C (95 Deg F to 151 Deg F)

---

**NOTE:**

Model 743 and Model 744 VME Board Computers are to be operated only in an environment that is free from conductive pollution, including dry non-conductive pollution which could become conductive due to expected condensation.

---

**CAUTION:**

Integrated circuit case and junction temperatures must not exceed those shown in Figure 4-3 and Figure 4-4.

---

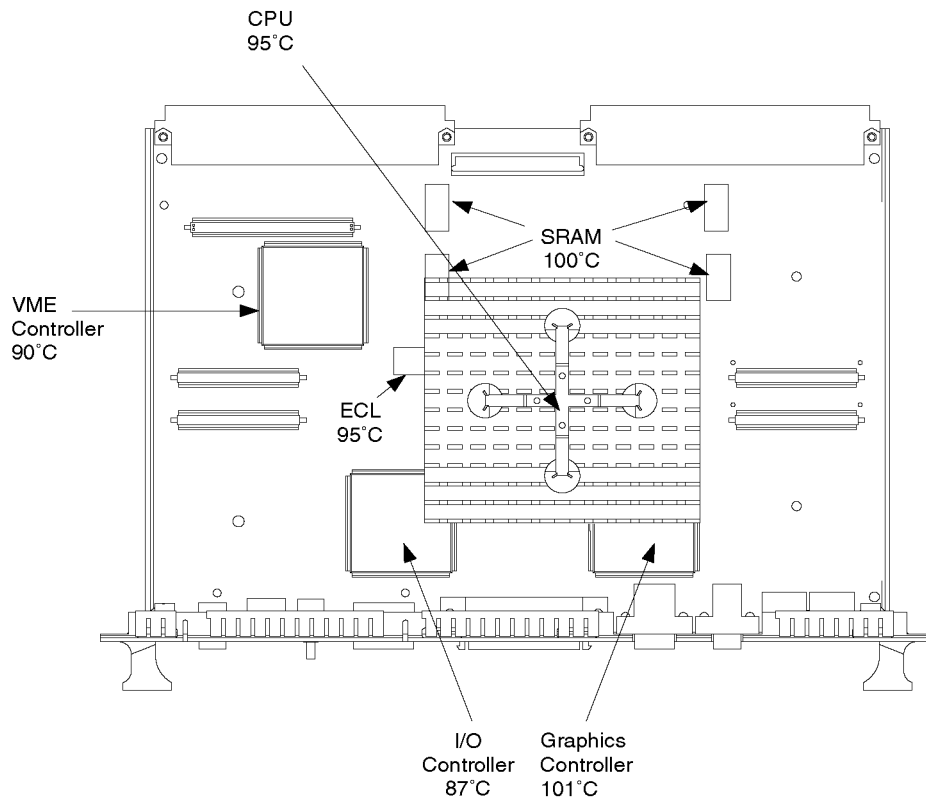


Figure 4-3 Model 743 Integrated Circuit Case Temperature Limits

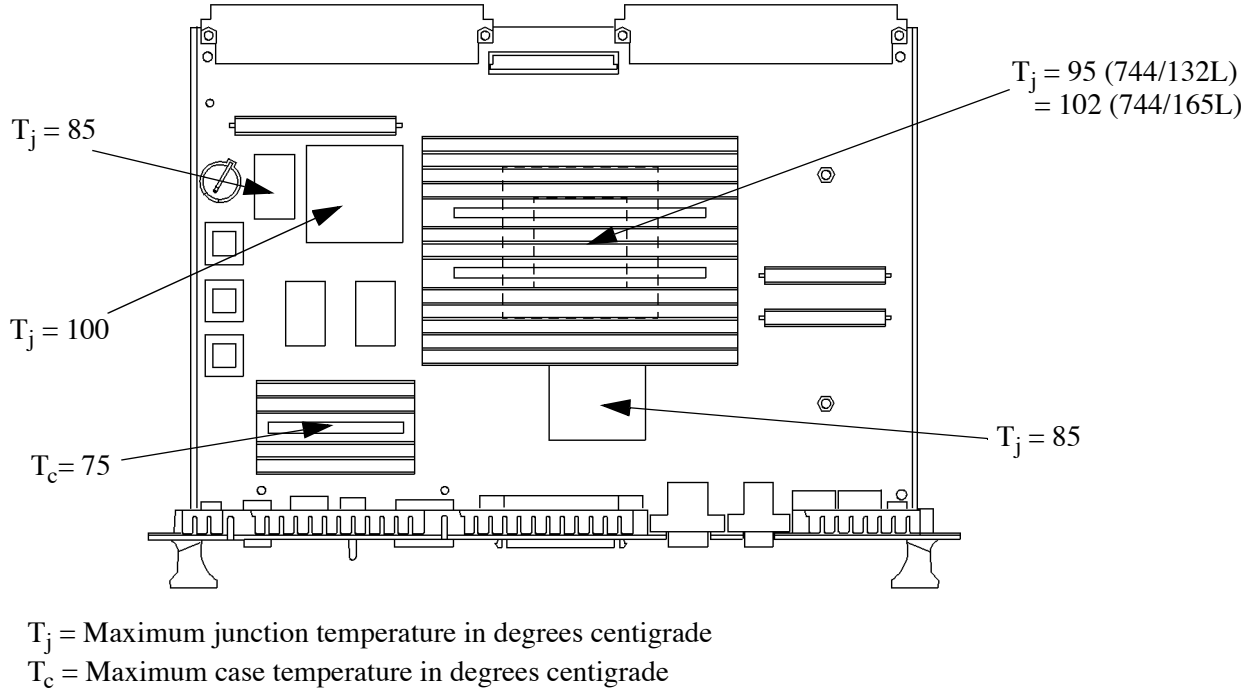


Figure 4-4 Model 744 Integrated Circuit Case Temperature Limits

### Interface Connectors

Table 4-1 lists the interface connector manufacturing data.

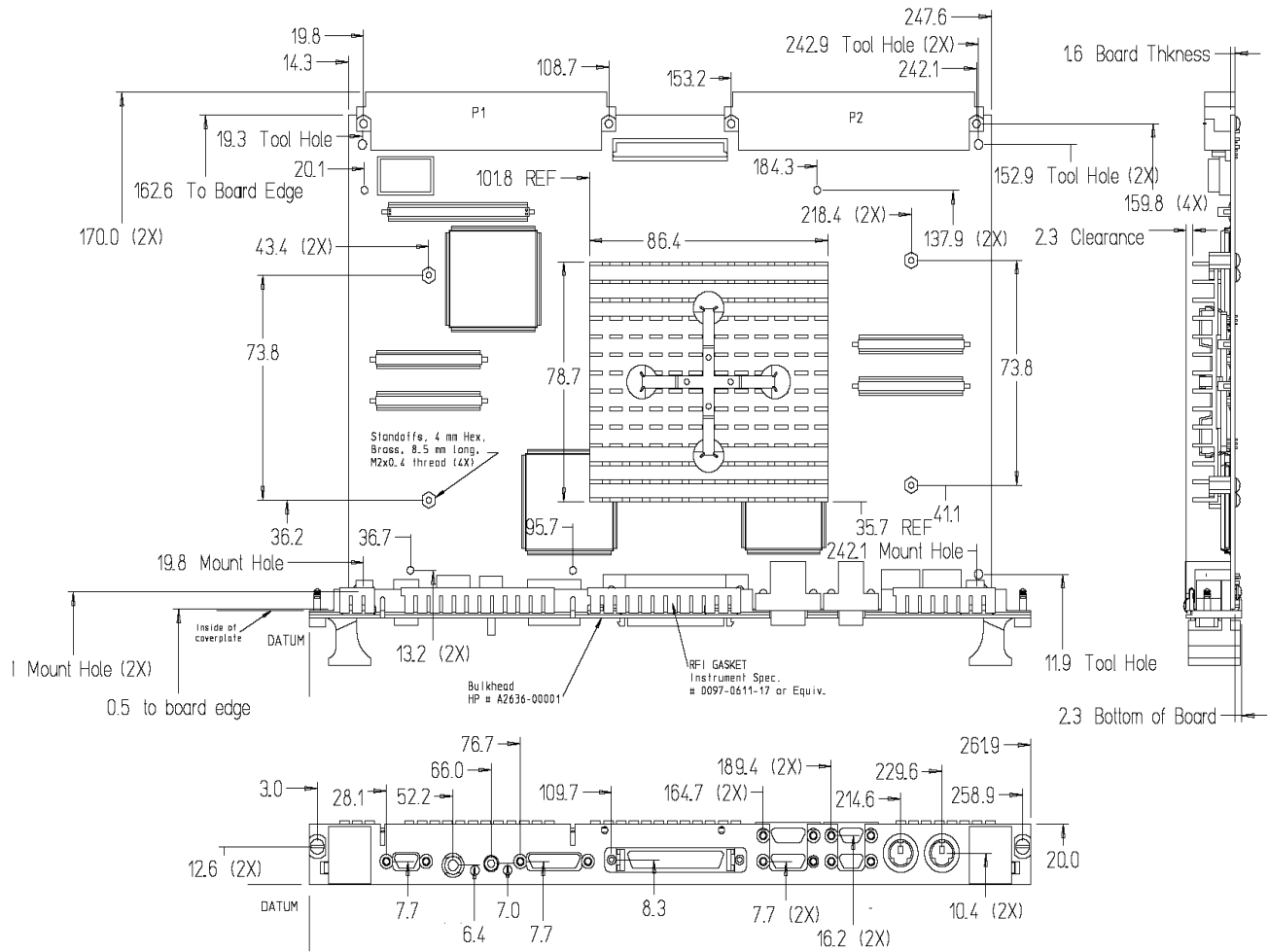
**Table 4-1**      **Interface Connector Manufacturing Data**

Connector	Manufacturing Data	Manufacturing Part Number
Audio	ITT Canon	MDSM-9PE-Z10 or equivalent
HP Parallel	ITT Canon	MDSM-25PE-Z10 or equivalent
Mouse/Keyboard	AMP	750071-1 or equivalent
P1	AMP	215606-4 or equivalent
P2	AMP	650988-0 or equivalent
SCSI II	AMP	749830-5 or equivalent
Serial	ITT Canon	MDSM-18PE-Z22 or equivalent
Speaker	Hosiden	HSJ3062-01-410 or equivalent
Video/LAN	ITT Canon	MDSM-30PE-z10 or equivalent



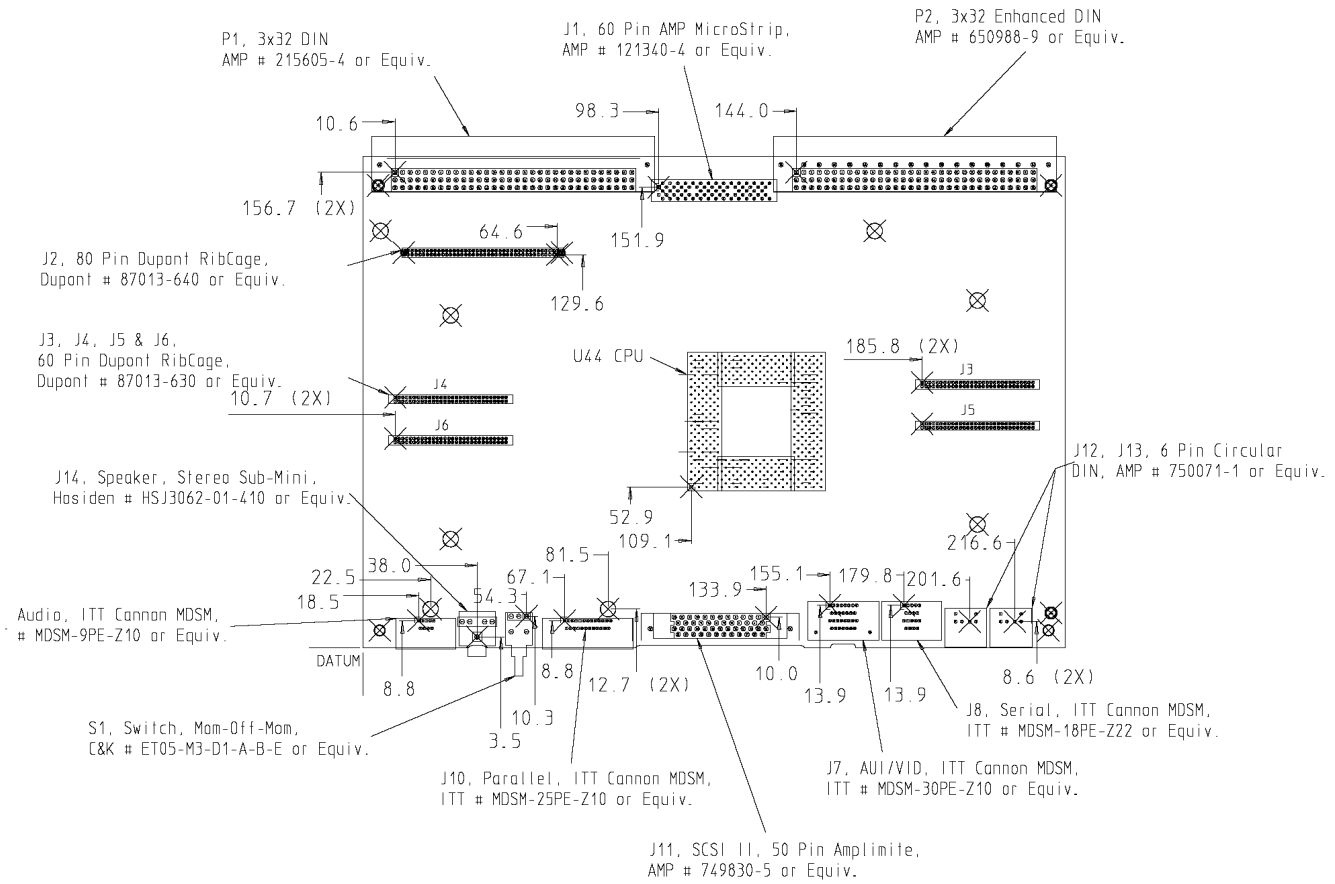
**Mechanical Dimensions**

Figure 4-5 and Figure 4-6 show the dimensions of the Model 743 board computer.



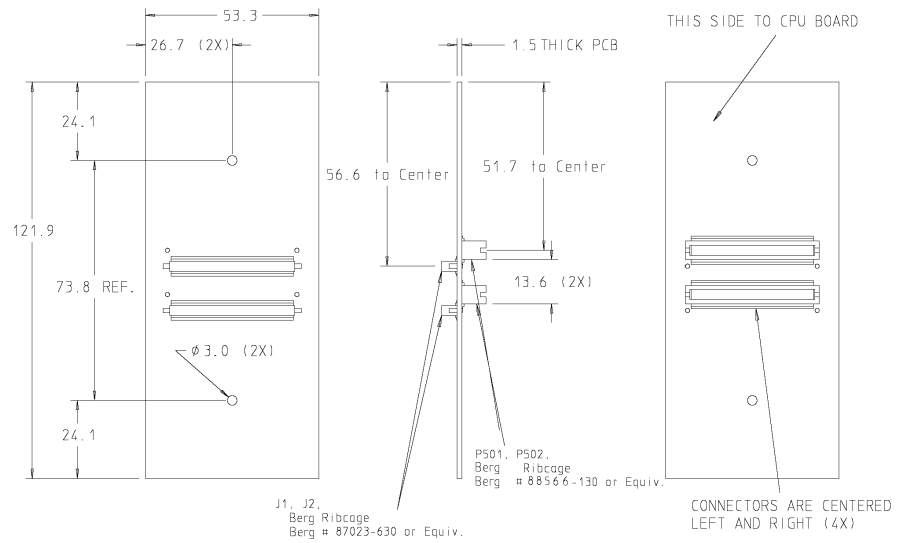
**Figure 4-5 Model 743 Board Computer**

**Mechanical Information**  
**Model 743 and Model 744 VME Board Computers**



**Figure 4-6 Model 743 Board Computer (Continued)**

Figure 4-7 shows the dimensions of a Model 743 RAM card.



**Figure 4-7**                      **Model 743 RAM Card**

Mechanical Information  
Model 743 and Model 744 VME Board Computers

Figure 4-8 through Figure 4-12 show the dimensions of the Model 744 system board.

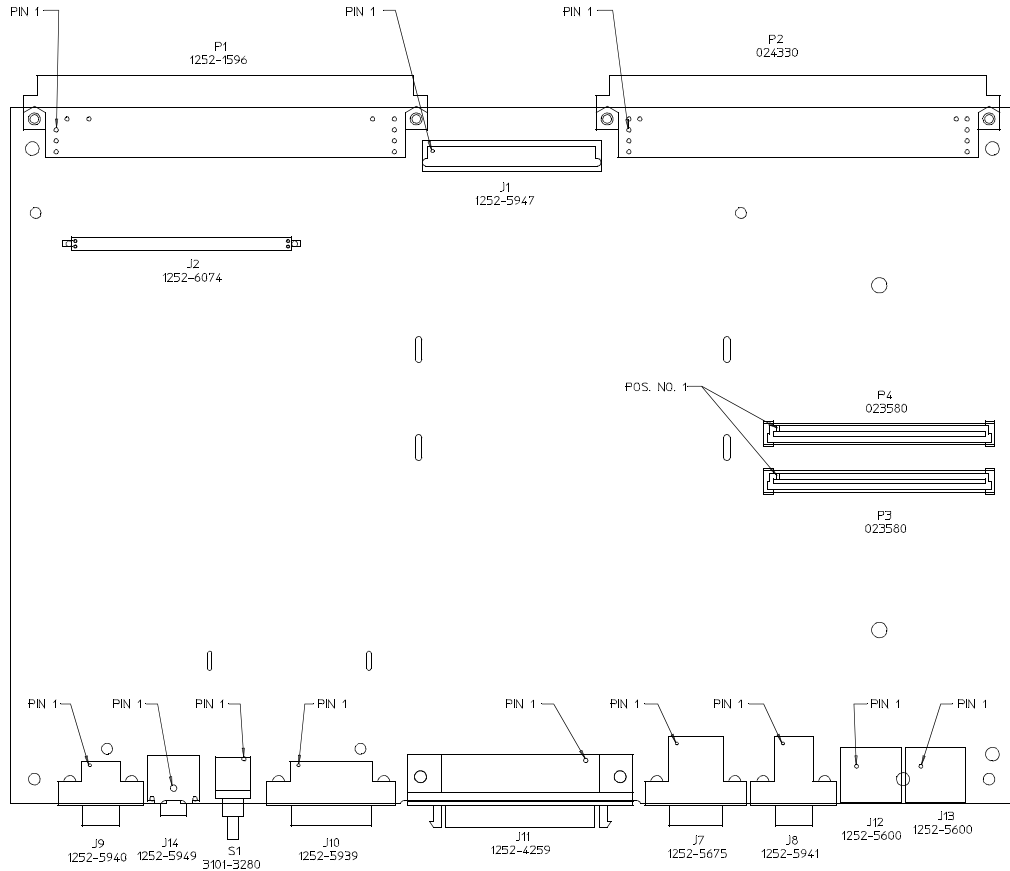


Figure 4-8 Model 744 Board Computer

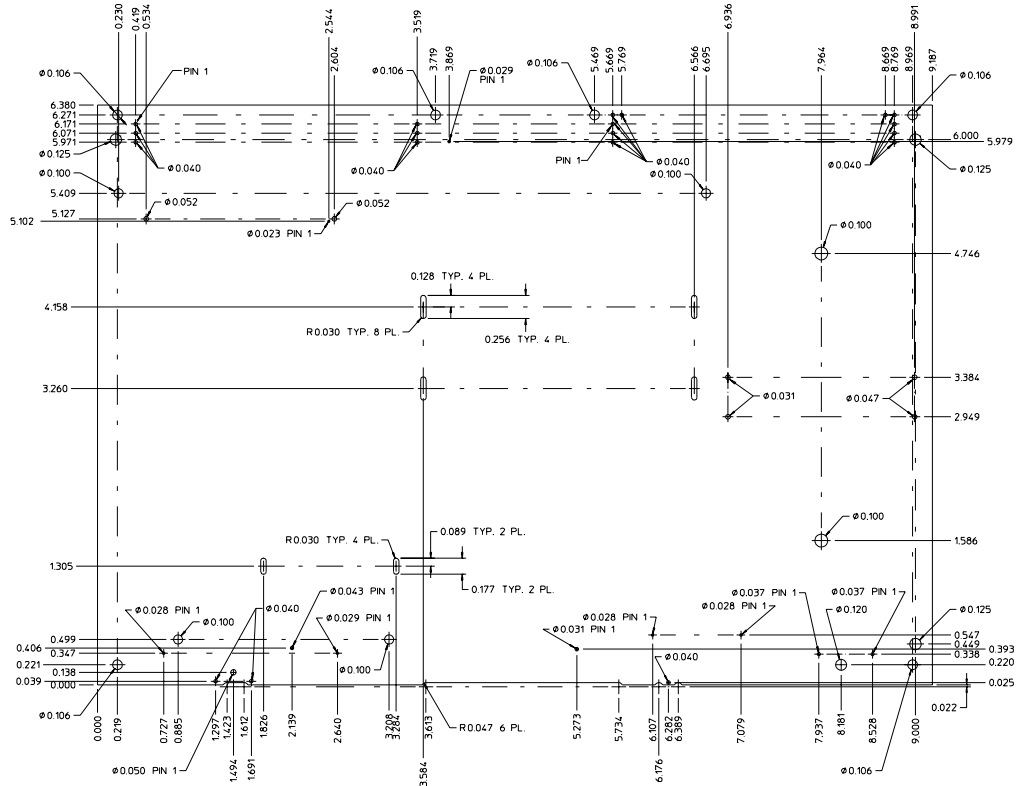


Figure 4-9 Model 744 Board Computer (Continued)

Mechanical Information  
Model 743 and Model 744 VME Board Computers

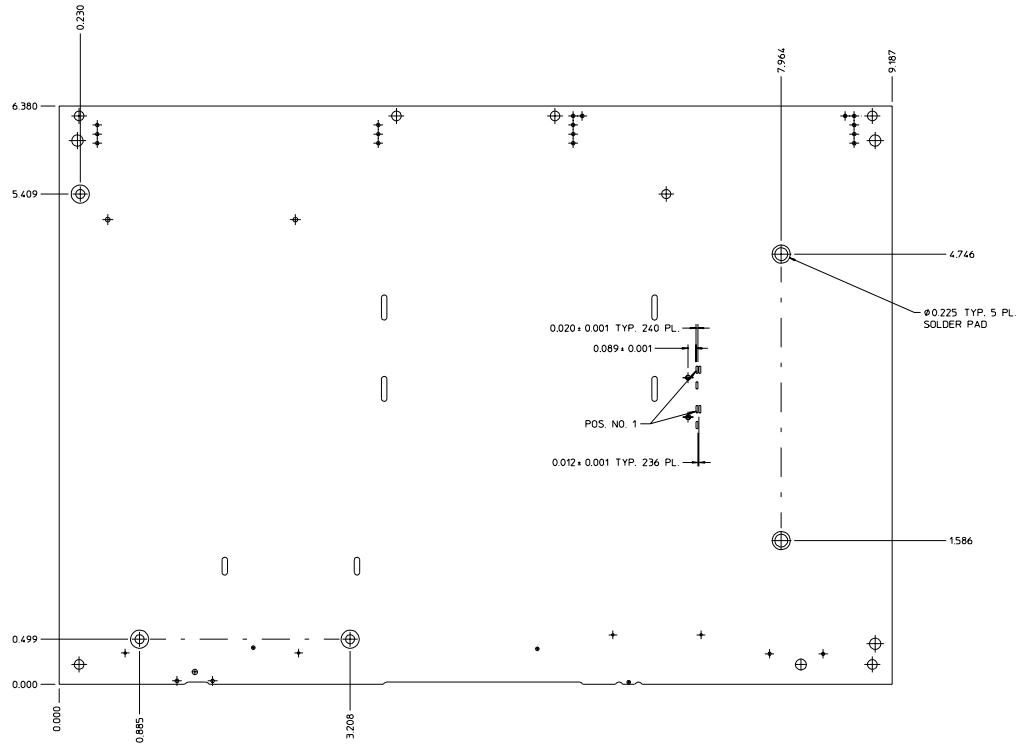


Figure 4-10 Model 744 Board Computer (Continued)

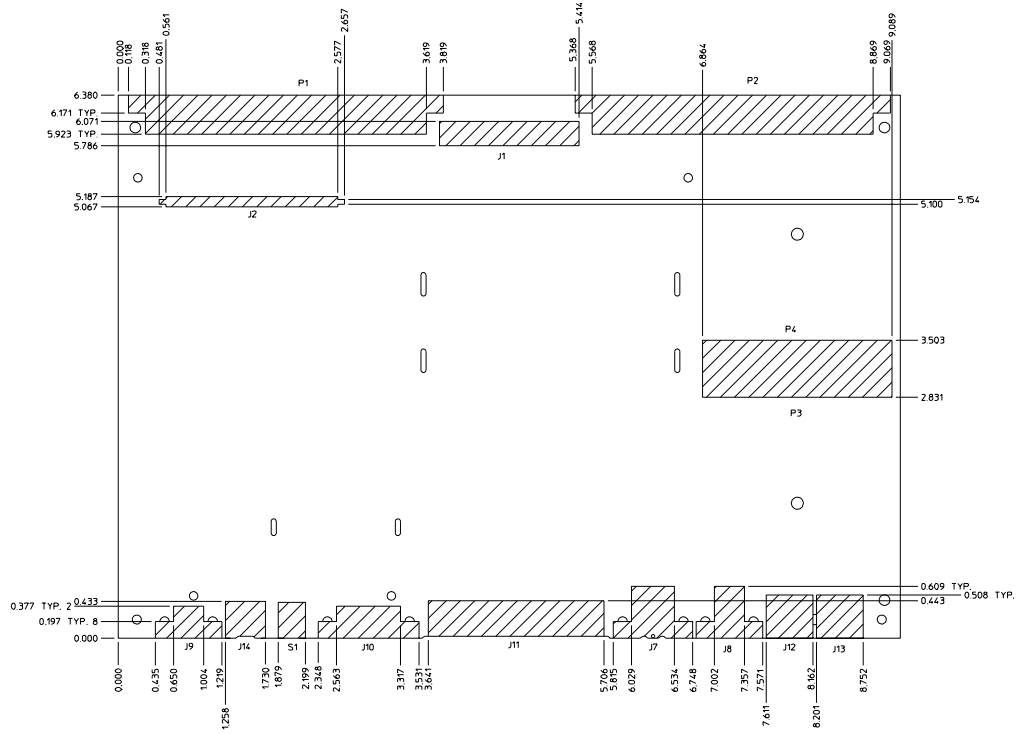


Figure 4-11 Model 744 Board Computer (Continued)

Mechanical Information  
 Model 743 and Model 744 VME Board Computers

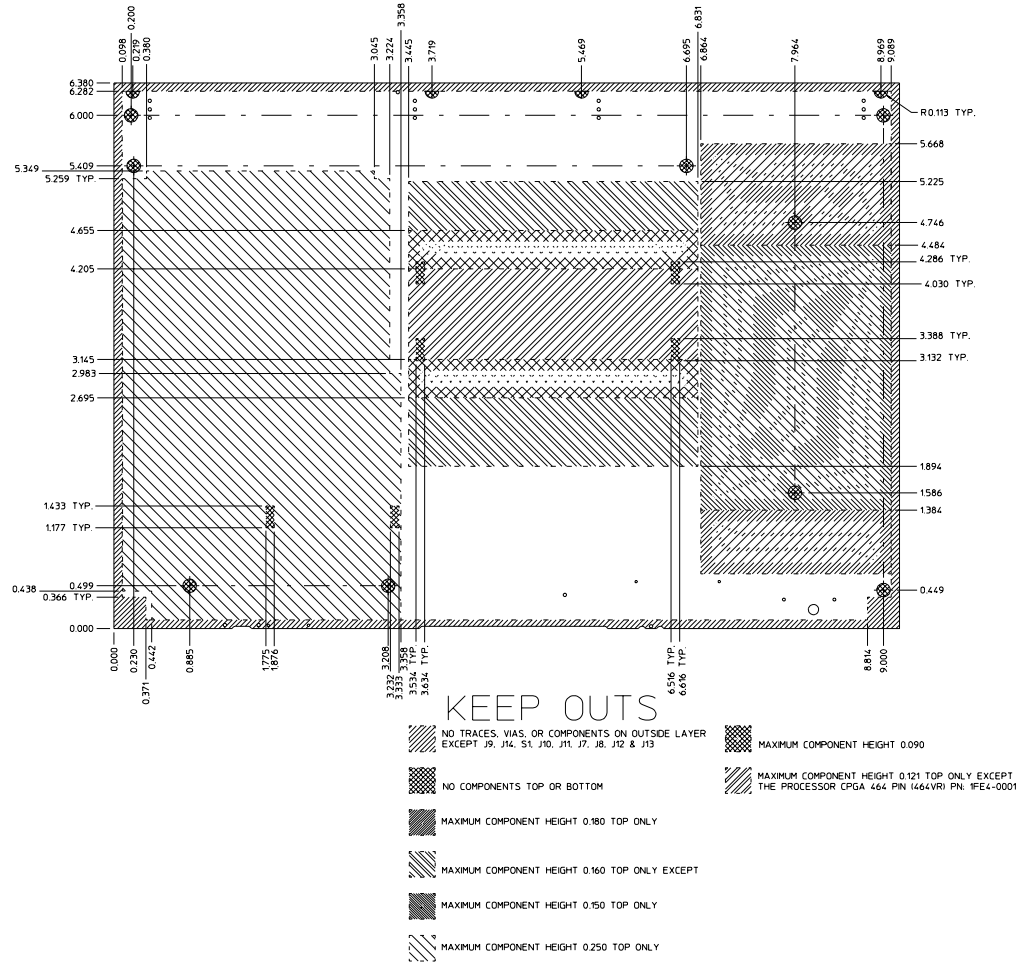
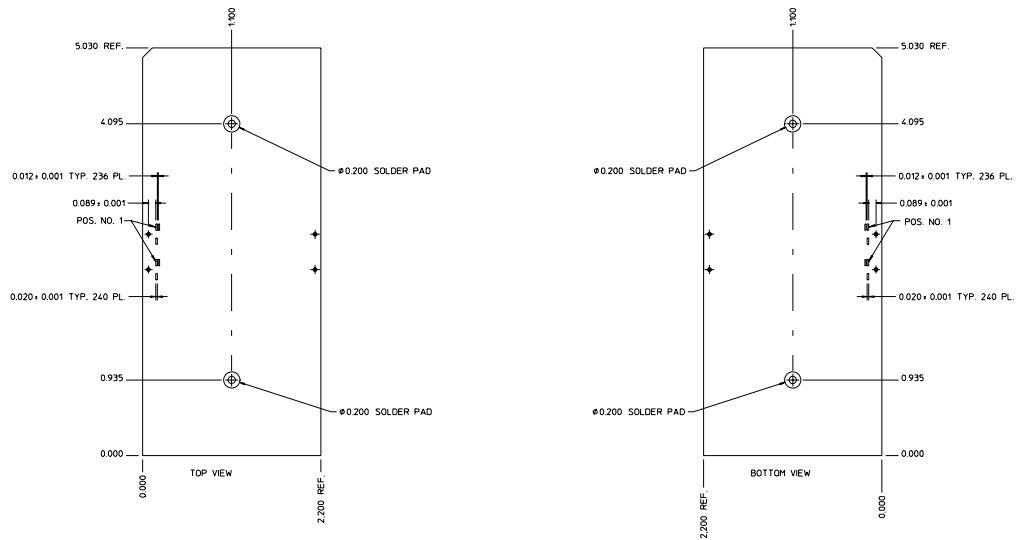


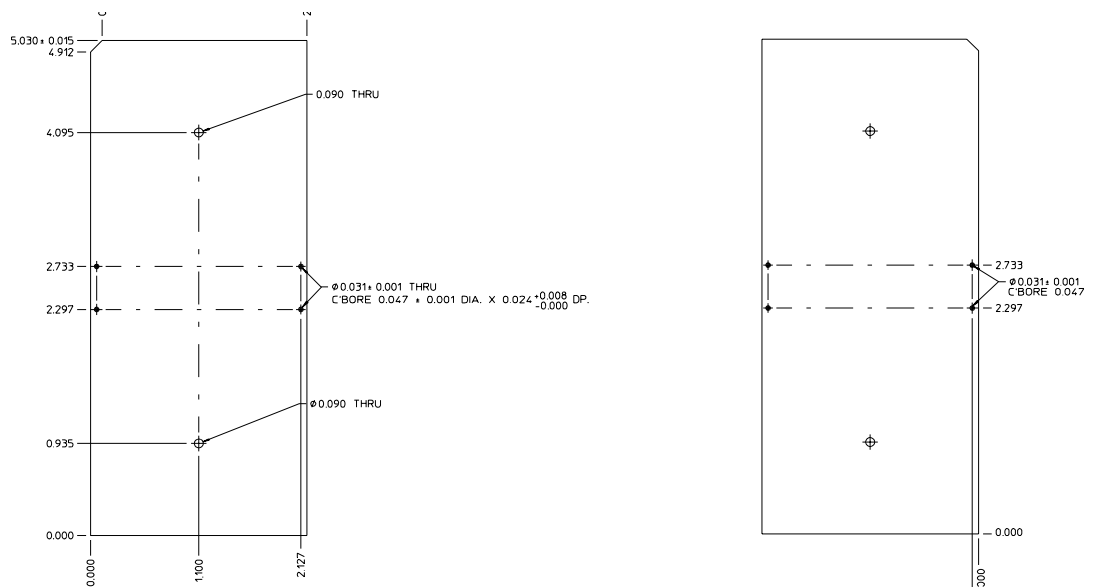
Figure 4-12 Model 744 Board Computer (Continued)



Figure 4-13 through Figure 4-15 show the dimensions of a Model 744 RAM card.

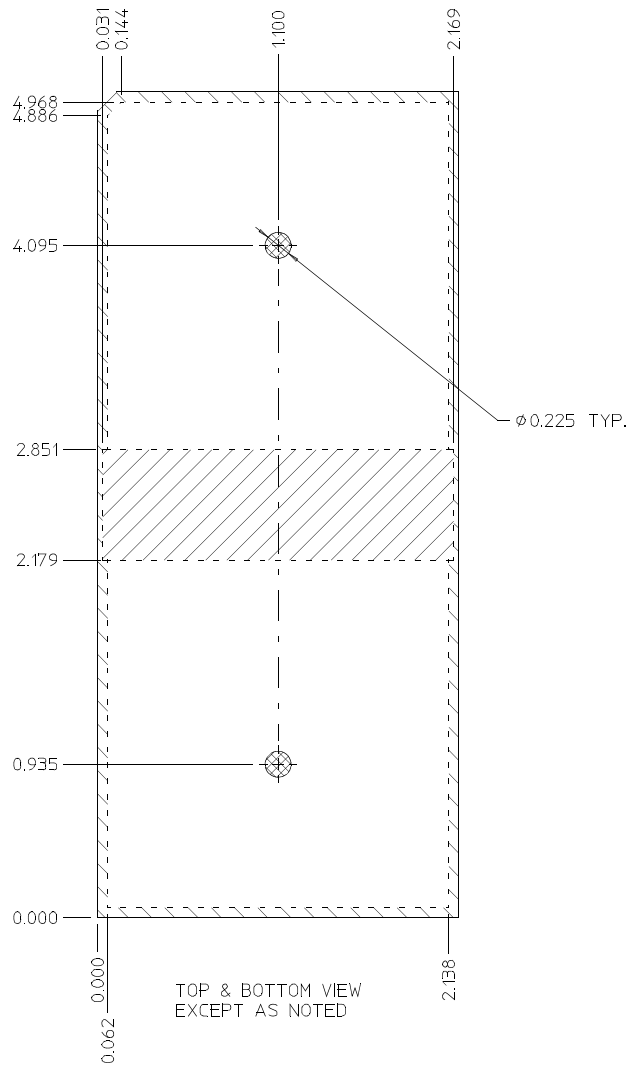





**Figure 4-13** **Model 744 RAM Card**



**Figure 4-14** **Model 744 RAM Card (Continued)**

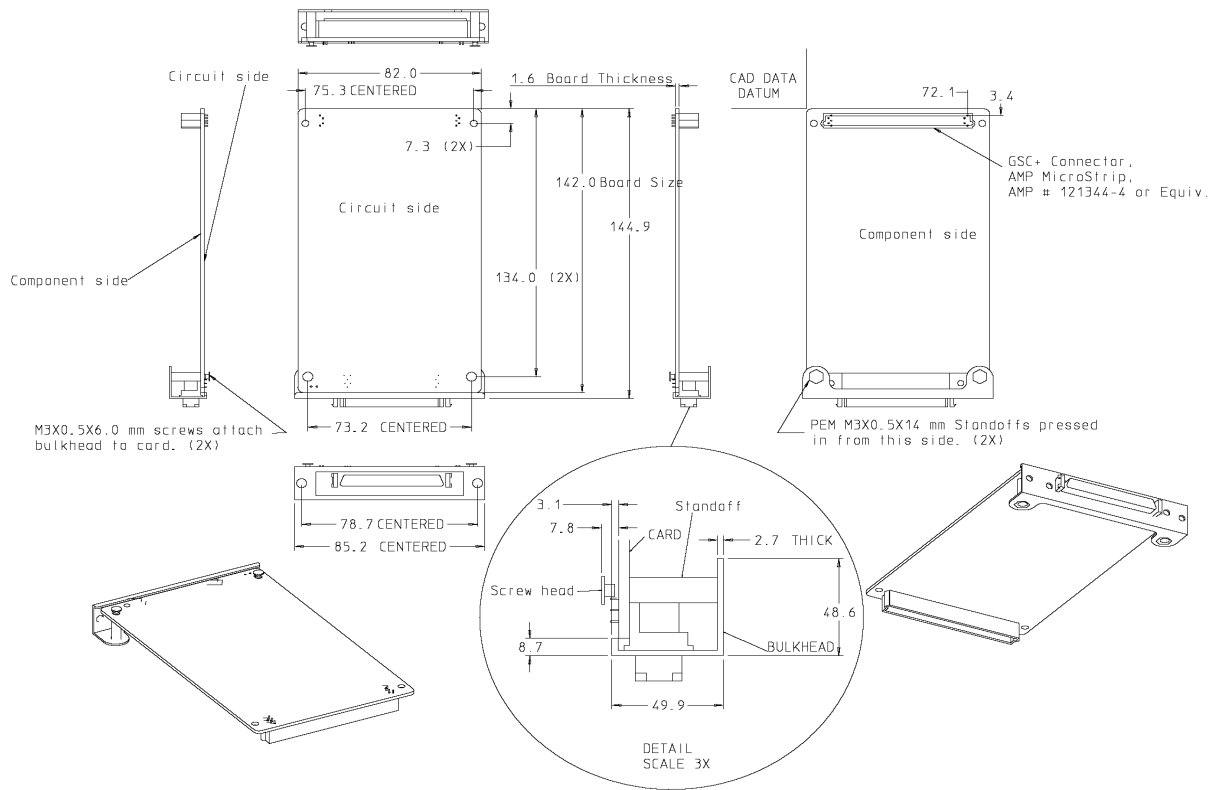
Mechanical Information  
**Model 743 and Model 744 VME Board Computers**



-  NO TRACES, VIAS, OR COMPONENTS ON OUTSIDE LAYERS EXCEPT J1 & J2
-  NO COMPONENTS
-  NO COMPONENTS EXCEPT J1 & J2

**Figure 4-15 Model 744 RAM Card (Continued)**

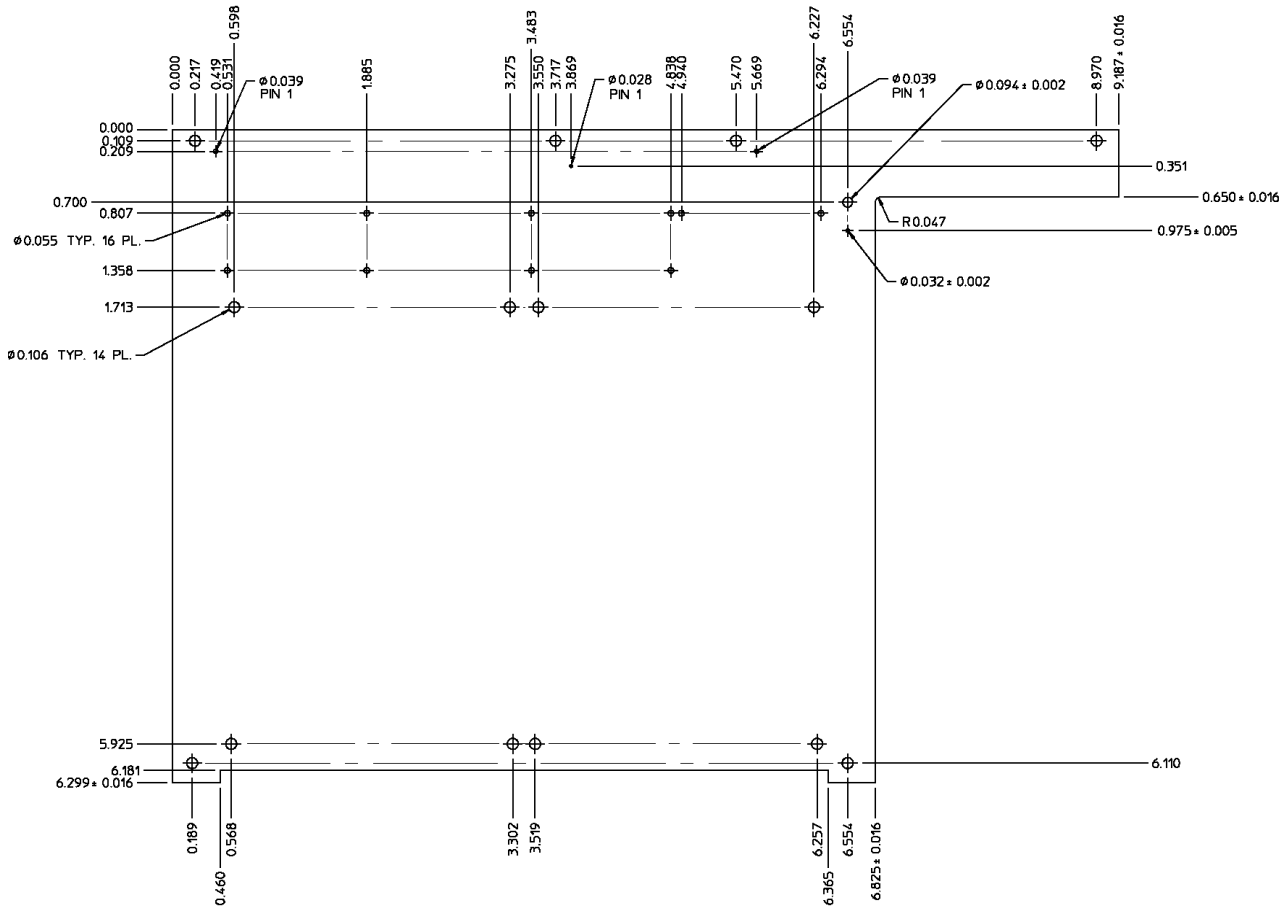
Figure 4-16 shows the dimensions of a GSC+ accessory card.



**Figure 4-16**                      **GSC Accessory Card**

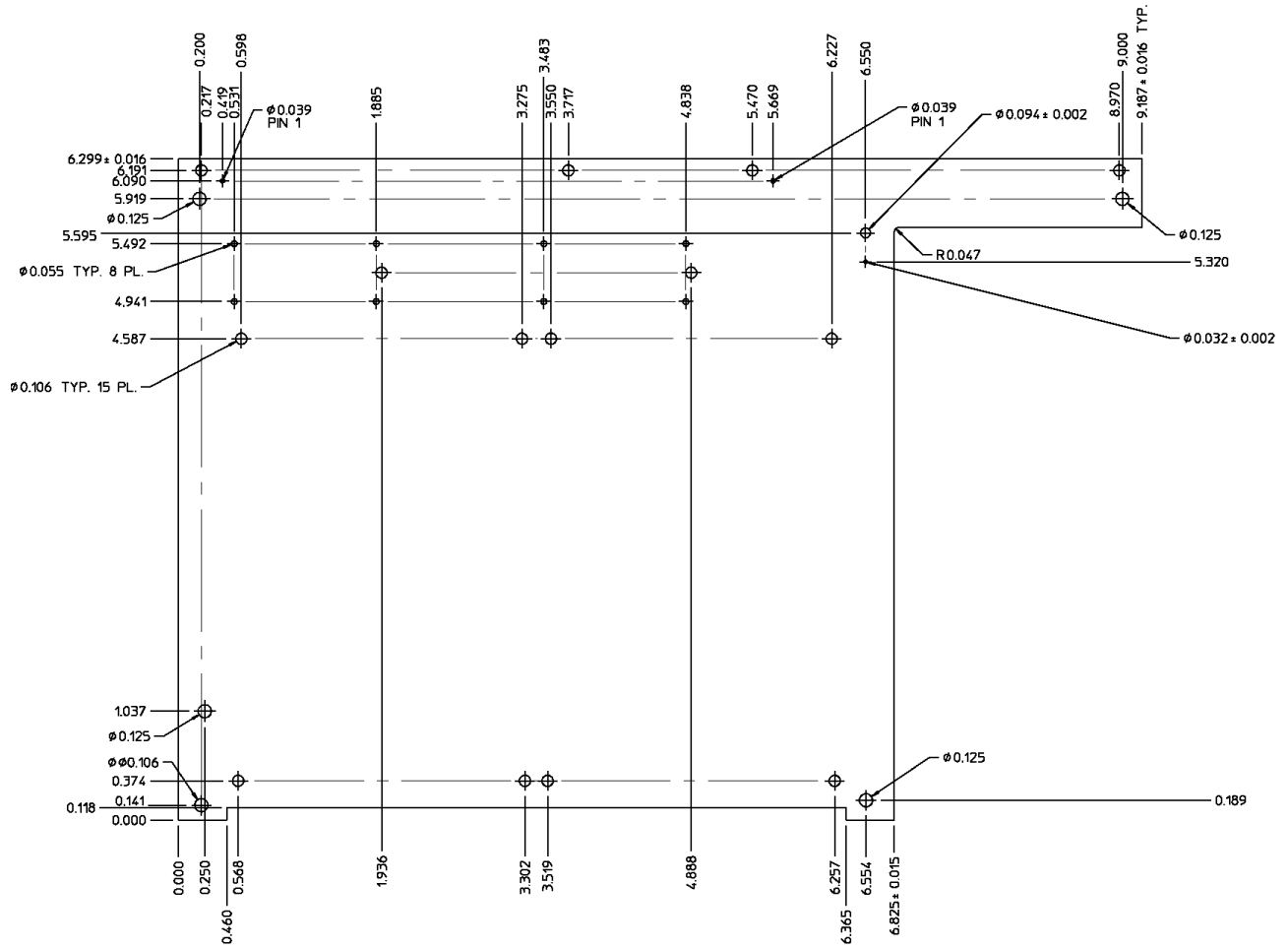
Mechanical Information  
**Model 743 and Model 744 VME Board Computers**

Figure 4-17 shows the dimensions of the PMC Bridge Adapter.



**Figure 4-17**      **PMC Bridge Adapter**

Figure 4-18 shows the dimensions of the PMC Expansion Adapter.



**Figure 4-18** PMC Expansion Adapter

## Model 748 Chassis and Modules

Figure 4-19 shows the dimensions of the Model 748 chassis.

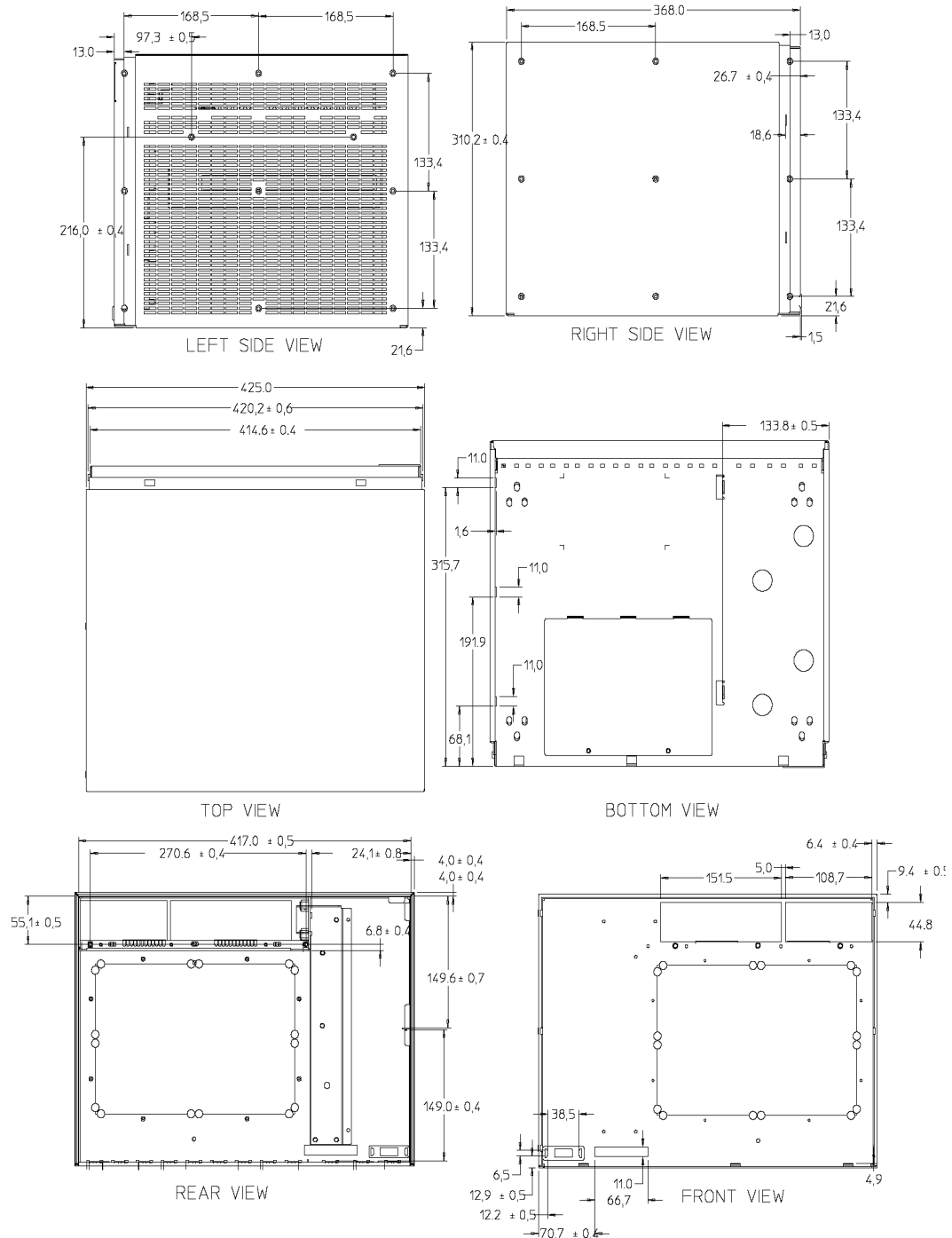
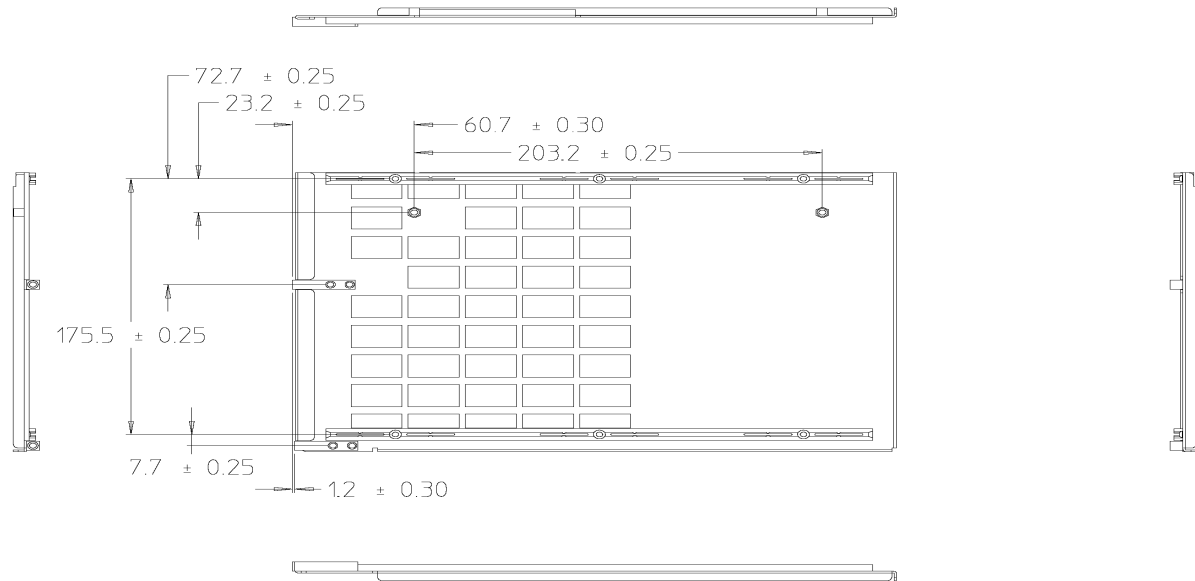


Figure 4-19

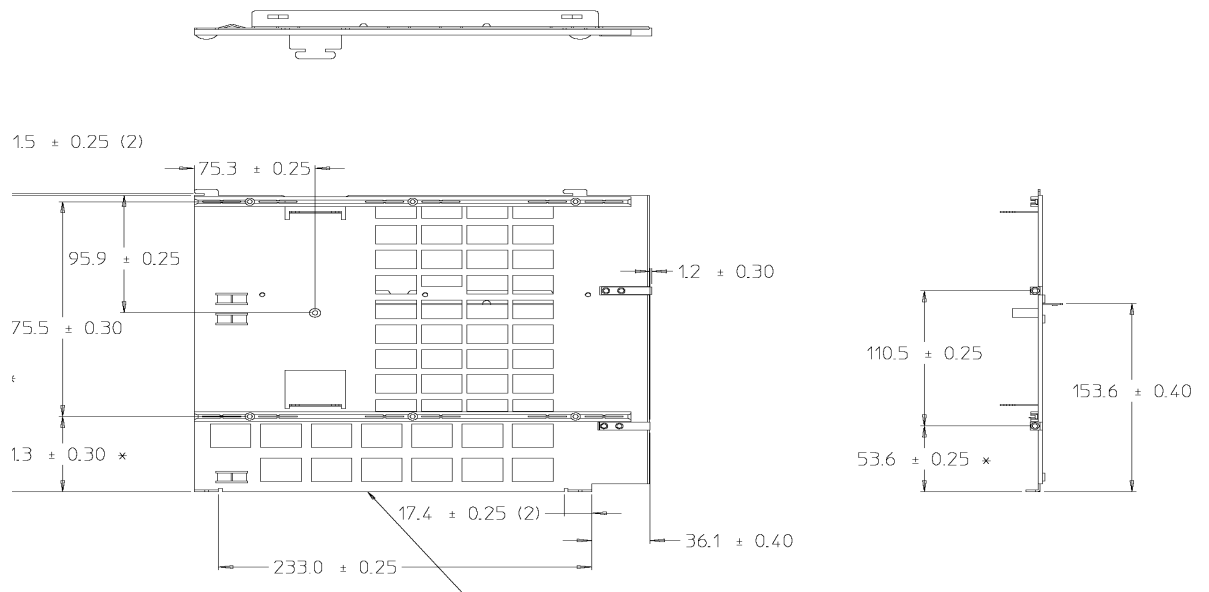
Model 748 Main Chassis

Figure 4-20 shows the dimensions of the Model 748 outside wall.



**Figure 4-20**                      **Model 748 Outside Wall**

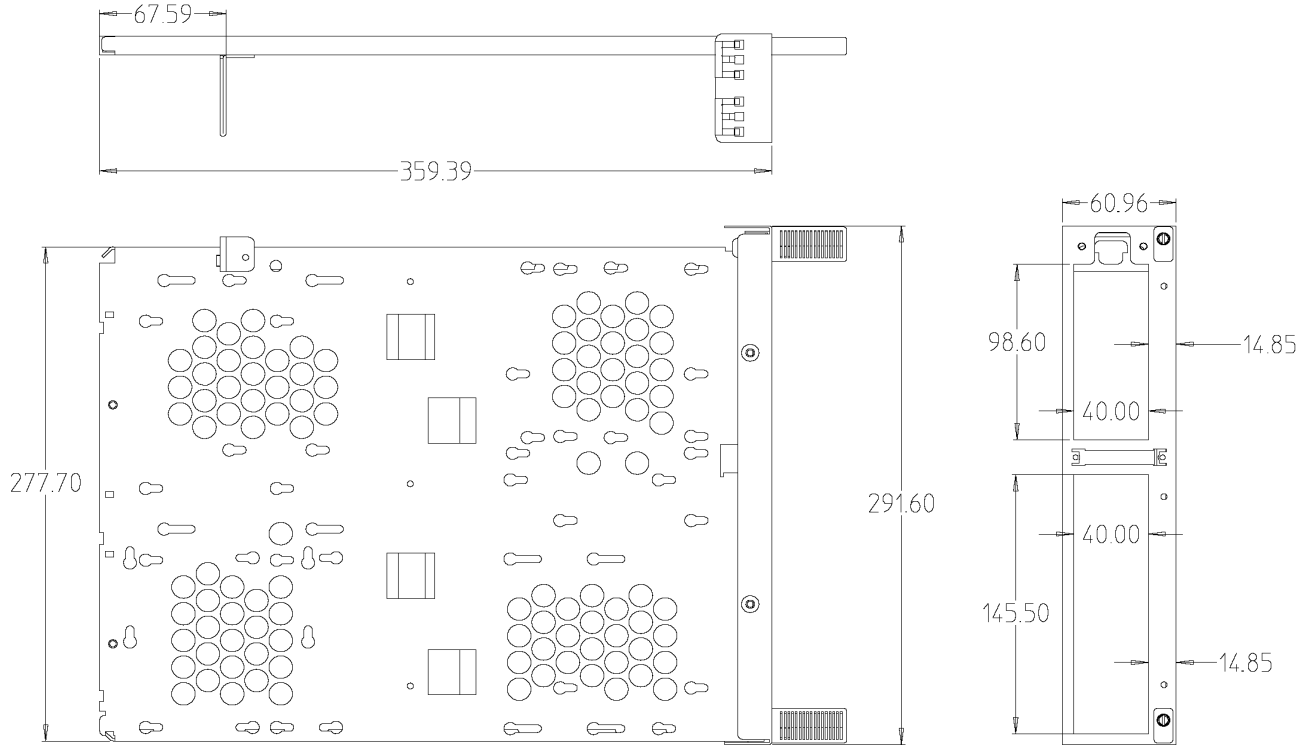
Figure 4-21 shows the dimensions of Model 748 center wall.



**Figure 4-21**                      **Model 748 Center Wall**

Mechanical Information  
**Model 748 Chassis and Modules**

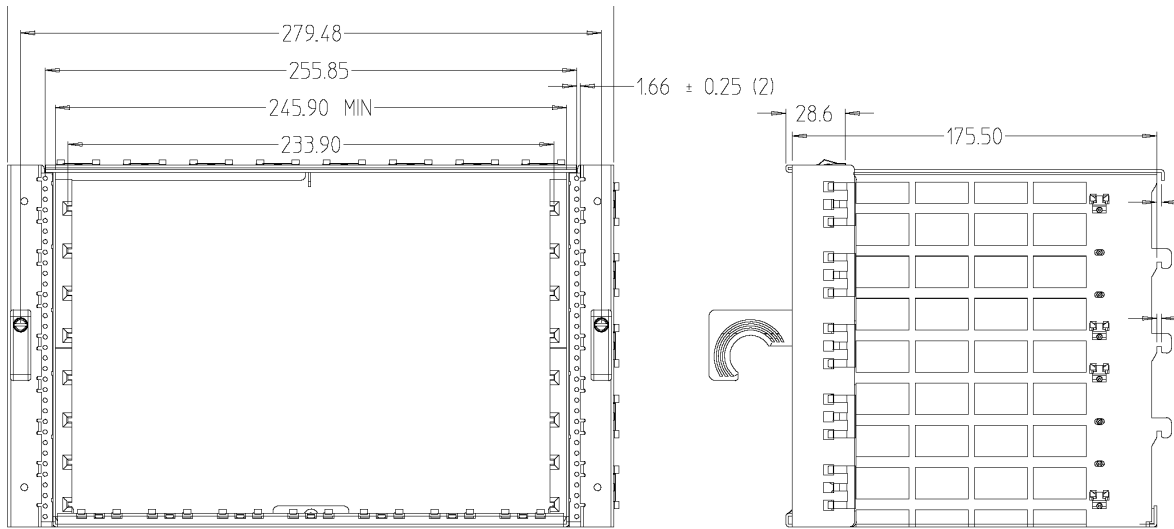
Figure 4-22 shows the dimensions of the Model 748 mass storage module chassis.



**Figure 4-22**      **Model 748 Mass Storage Module Chassis**



Figure 4-23 shows the dimensions of the Model 748 VME module chassis.



**Figure 4-23**                      **Model 748 VME Module Chassis**

Mechanical Information  
Model 748 Chassis and Modules

Figure 4-24 shows the dimensions of the Model 748 PCI/EISA module chassis.

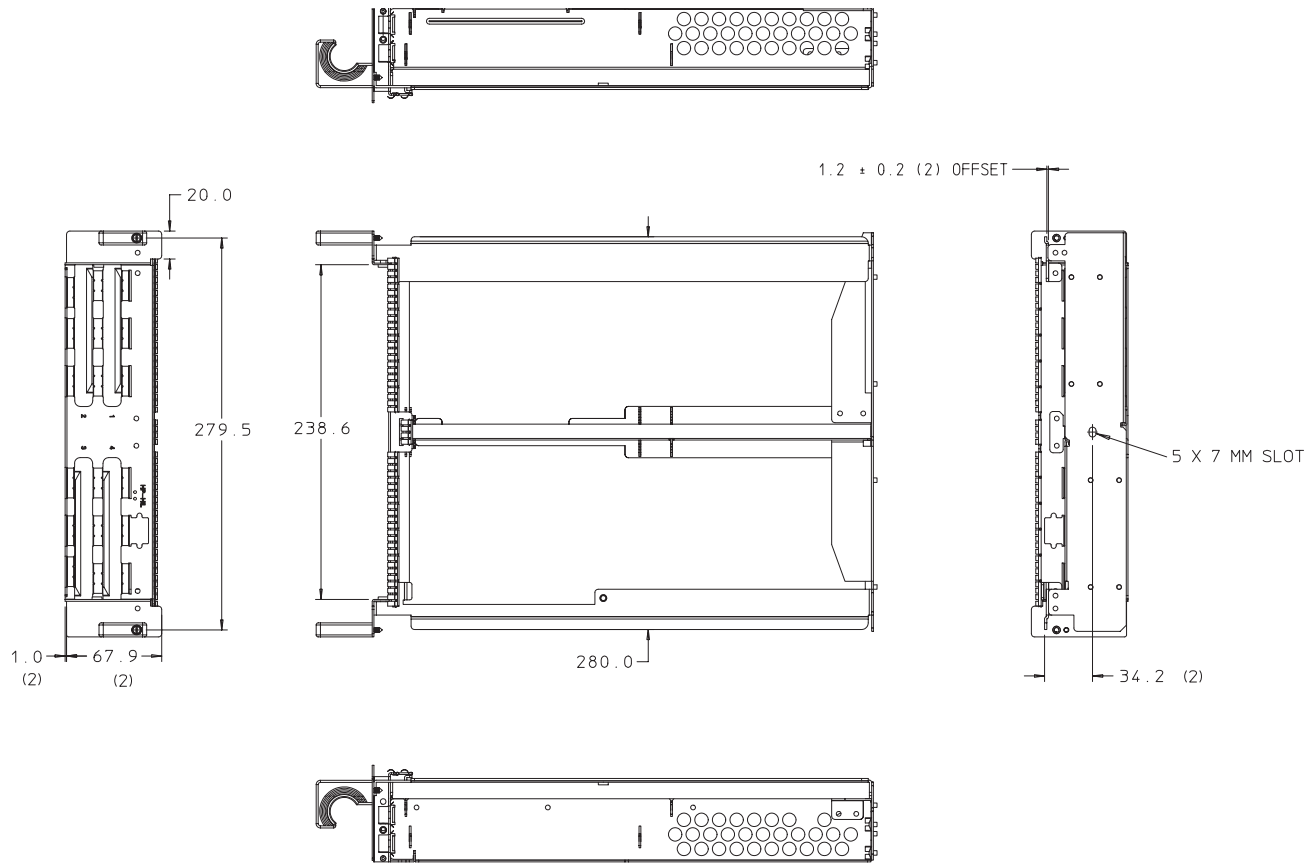
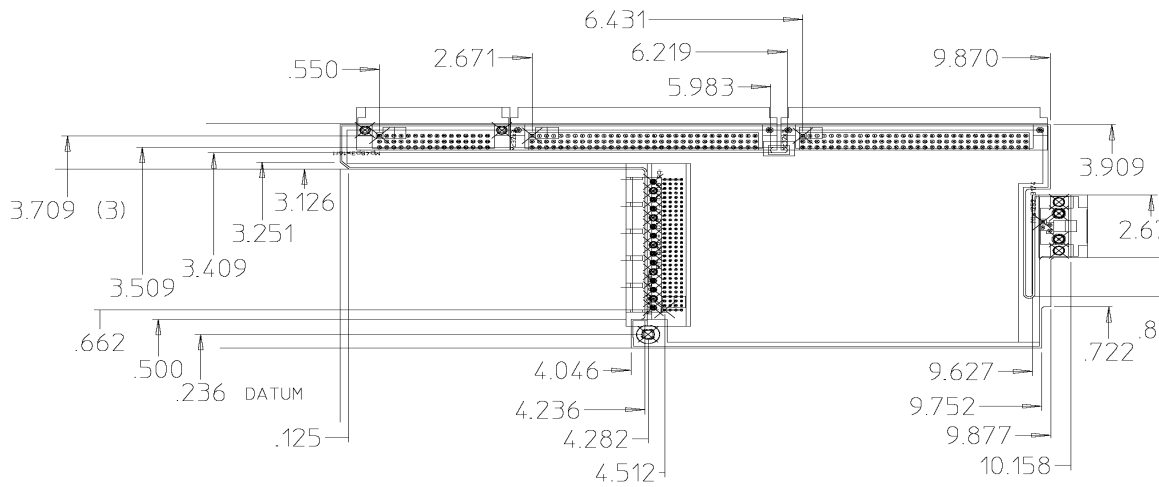


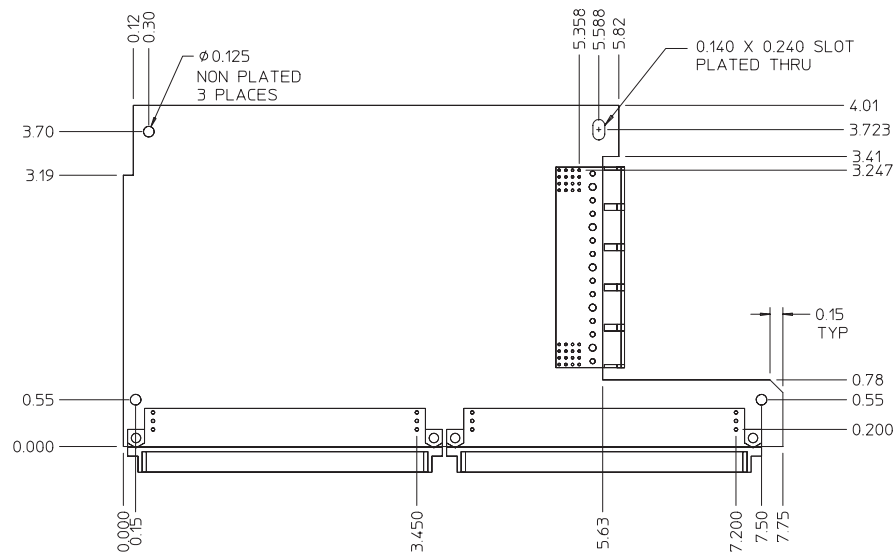
Figure 4-24 Module 748 PCI/EISA Module Chassis

Figure 4-25 shows the dimensions of the Model 748 EISA converter board.



**Figure 4-25 Model 748 EISA Converter Board**

Figure 4-26 shows the dimensions of the Model 748 PCI converter board.



**Figure 4-26 Model 748 PCI Converter Board**

Mechanical Information  
Model 748 Chassis and Modules

Figure 4-27 shows the dimensions of the Model 748 VME backplane board.

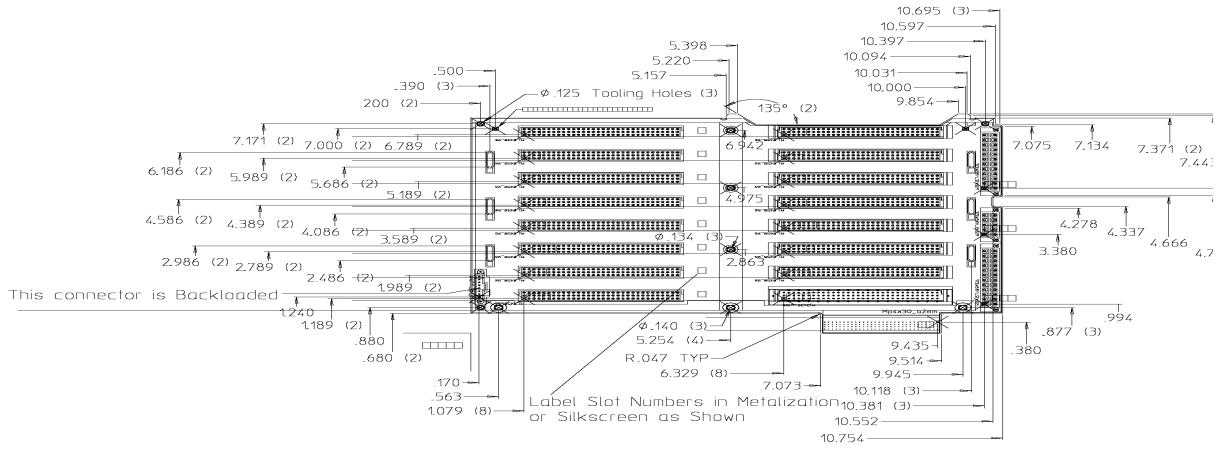


Figure 4-27 Model 748 VME Backplane Board

Figure 4-28 shows the dimensions of the Model 748 power distribution board.

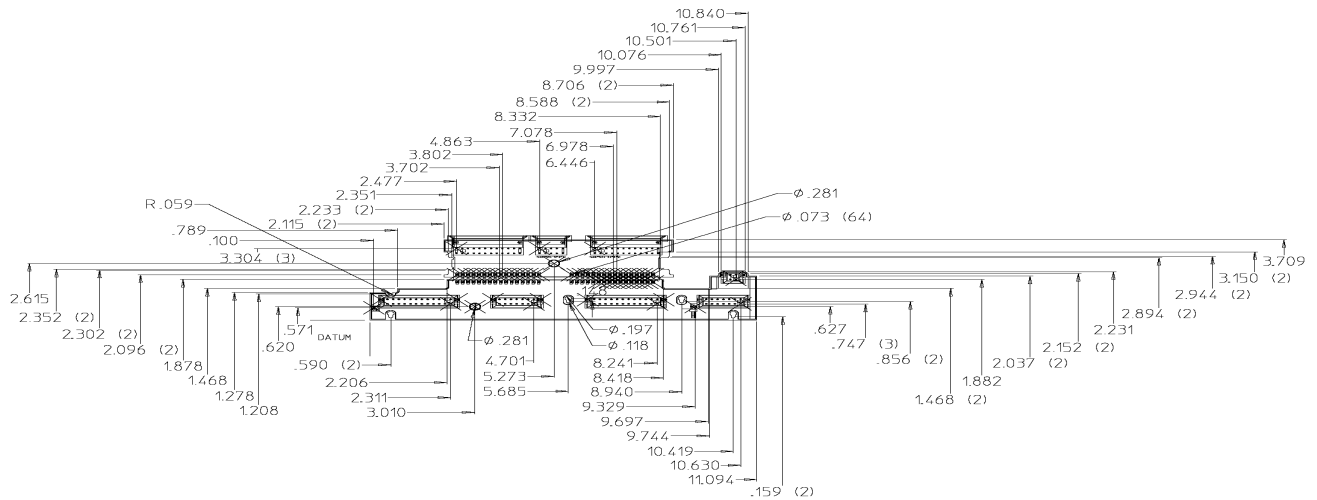


Figure 4-28 Model 748 Power Distribution Board

## Weights

Table 4-2 lists the weights of the components of the Model 748 workstation.

**Table 4-2 Weights of Model 748 Workstation Product and Modules**

Part Name	Metric Weight	English Weight
Model 748 Ruggedized Workstation chassis including power distribution board, on/off switch, and front cover (does not include modules or board computer)	9.50 Kg	21 lbs. 2.0 oz.
SE Mass storage module including SCSI and power cables	2.03 Kg	4 lbs. 8.1 oz.
FWD Mass storage module including SCSI and power cables	2.25 Kg	5 lbs. 0 oz.
Disk drives (maximum weight)	0.95 Kg	2 lbs. 1.6 oz.
VME backplane	0.63 Kg	1 lb. 6.4 oz.
VME module (including six slot cover)	1.91 Kg	4 lbs. 4.0 oz.
VME module (without slot covers)	1.65 Kg	3 lbs. 10.4 oz.
VME slot cover	0.05 Kg	1.7 oz.
PCI/EISA module	1.13 Kg	2 lbs. 8.3 oz.
EISA converter board/backplane	0.47 Kg	1 lb. 0.7 oz.
PCI converter board/backplane	0.37 Kg	13.2 oz.
Power supply	3.43 Kg	7 lbs. 9.5 oz.
Model 743 Board Computer with on-board graphics (no other options)	0.47 Kg	1 lb. 0.7 oz.
Model 744 Board Computer with on-board graphics (no other options)	0.62 Kg	1 lb. 1.7 oz.
Model 743 RAM card	0.05 Kg	1.6 oz.
Model 744 RAM card	0.05 Kg	1.6 oz.
GSC Expansion kit	0.17 Kg	6.1 oz.
PMC bridge board with mounting hardware (no blank bezels)	0.27 Kg	7.6 oz.
PMC expansion board with mounting hardware (no blank bezels or sleeves)	0.24 Kg	6.8 oz.
PMC blank bezels (each)	0.03 Kg	0.8 oz.
PMC ejector handle sleeves	0.02 Kg	0.7 oz.
GSC graphics card	0.10 Kg	3.6 oz.
GSC FWD SCSI card	0.11 Kg	3.8 oz.
HCRX/8 graphics card	0.27 Kg	7.7 oz.
HCRX/24 graphics card	0.29 Kg	8.4 oz.
GSC ATM card	0.14 Kg	4.0 oz.

## **Mounting and Support**

Each Model 748 workstation is shipped with a rack mount kit including flanges, spacers, and screws. In this section, the term "back" refers to the cable-out side of the workstation. Model 748 satisfies three rack mount orientations:

- Mast mount
- Rack mount, either front out or back out

Power switching is accessible from both front and back. A single power LED is on the front. Status and test LEDs are located on the Model 743 Model 744 VME Board Computers. If the power supply and VME board computer LEDs must be visible, mount the workstation back out. Devices within the mass storage module can be arranged for front or back accessibility.

- Wall mount

PCI/EISA and VME card cages are fixed and cannot be reversed.

## **Mechanical Drawings**

For OEMs that have signed a Hewlett-Packard non-disclosure agreement, the mechanical drawings are available by request from the Workstation Systems Group through your Hewlett-Packard OEM Sales Representative. These drawings are Hewlett-Packard confidential and cannot be redistributed.

When you ask for drawings, please specify the following:

- Drawing part number, size, and page number, if needed
- Name, assembly or subassembly

The drawings are sent to your Sales and Service Office.

## **Conversion Cables**

All conversion cables are 762 plus or minus 30 mm (30 plus or minus 1.18 inch) long. The end of the cable that connects to the board computer uses a micro D-sub male (MDSM) connector. The other end of the cable uses a standard D-sub or other connector.

### Chassis Parts and Models

Table 4-3 shows the assembly group, included subassemblies, and mechanical drawing reference number for the Model 748 chassis parts and modules.

**Table 4-3 Mechanical Drawings for Chassis Parts and Modules**

Assembly Group	Included Subassemblies	Subassembly Drawing Number
Model 748 chassis	Trim piece	C-A2261-40019-10
	Front bezel (cover)	D-A2261-40003-10
	Light pipe assembly	D-A2261-40004-10
	Removable wall	C-A4309-00003-10
	Left wall assembly	C-A4309-00004-10
	Chassis	D-A4309-00011-10
	Power distribution board	D-A4309-66002-10
Mass storage module	Tray	D-A4309-00005-10
PCI/EISA module	4-slot chassis	C-A4309-00010-10
VME module	Card cage	D-A4309-00006-10
Power supply module		D-0950-2303-10
Model 743/744 system board	Front panel	D-A2636-00001-10
GSC expansion	GSC video bulkhead	C-A2636-00005-10
	Double-high bulkhead	D-A2636-00002-10
	GSC blank bulkhead	C-A2636-00010-10
	Blank VME bulkhead	D-A2636-00004-10
	Two-slot adapter board	D-A2636-66012-10
PMC expansion	PMC bridge adapter	D-A4504-66001-10
	PMC expansion adapter	D-A4505-66002-10

Mechanical Information  
**Model 748 Chassis and Modules**



---

## **Electrical Information**

The Electrical Information Chapter contains information on the connector pinouts, real-time clock battery, and video output signal specifications.

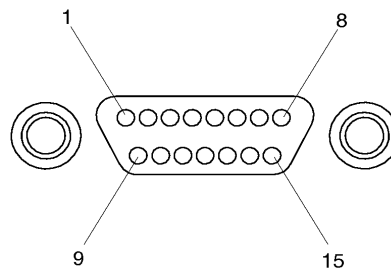
## Electrical Information

The sections that follow contain figures and tables of the connector pinouts and the wiring tables for video, audio, HP parallel, RS-232, AUI LAN, single-ended SCSI, FW SCSI, PS/2, and VMEbus; specifications for the real-time battery clock, video output signals, and video timing.

### Video Connector Pinouts

This section contains a figure of the video connector, a table of the video connector pinouts, the HP4304A conversion video cable connectors diagrams, and the conversion video cable wiring table.

Figure 5-1 illustrates the video connector pin locations for the Model 743 and Model 744 I/O backplane.



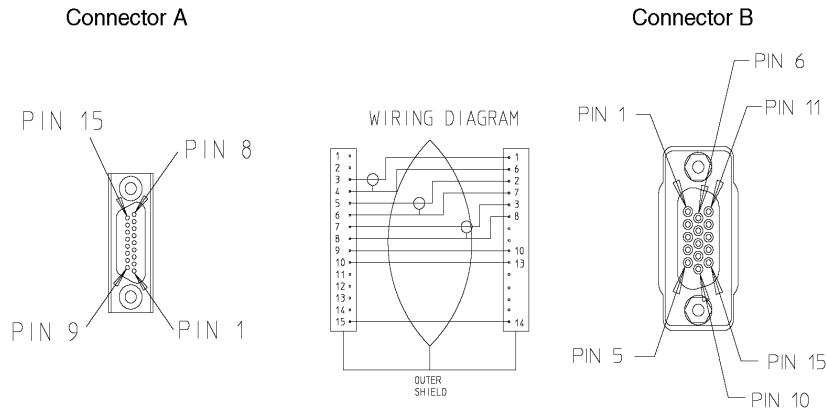
**Figure 5-1 Video Connector**

Table 5-1 identifies the pins on the Model 743 and Model 744 I/O backplane video connector.

**Table 5-1 Video Connector Pinouts**

Pin Number	Signal 743 / 744	Pin Number	Signal 743 / 744	Pin Number	Signal 743 / 744
1	GND / DDC	6	GND	11	GND / +5
2	GND	7	BLUE	12	GND
3	RED	8	GND	13	NC / SSYNC
4	GND	9	GND	14	GND
5	GREEN	10	HSYNC	15	VSYNC

Figure 5-2 illustrates the connector pin locations on each end of the HP A4304A conversion video cable.



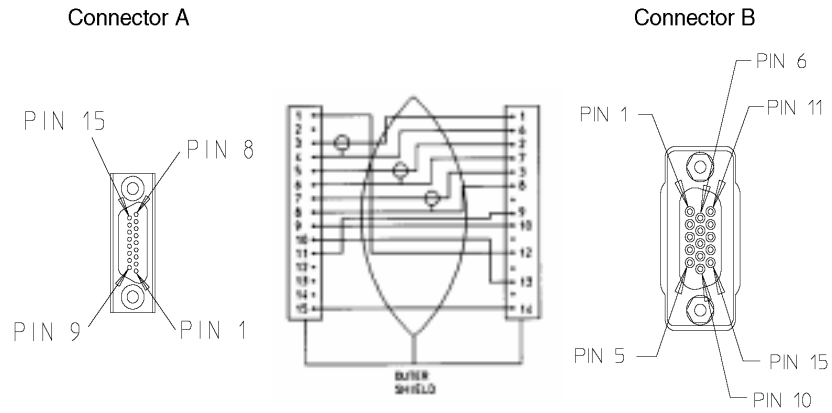
**Figure 5-2 HP A4304A Conversion Video Cable Connectors**

Table 5-5 identifies HP A4304A conversion video cable pins.

**Table 5-2 A4304A Conversion Video Cable Wiring Table**

15-Pin MDSM	15-Pin D-Sub
Pin 1	
Pin 2	
Pin 3	Pin 1
Pin 4	Pin 6
Pin 5	Pin 2
Pin 6	Pin 7
Pin 7	Pin 3
Pin 8	Pin 8
Pin 9	Pin 10
Pin 10	Pin 13
Pin 11	
Pin 12	
Pin 13	
Pin 14	
Pin 15	Pin 14

Figure 5-3 illustrates the connector pin locations on each end of the HP A4223A conversion video cable.



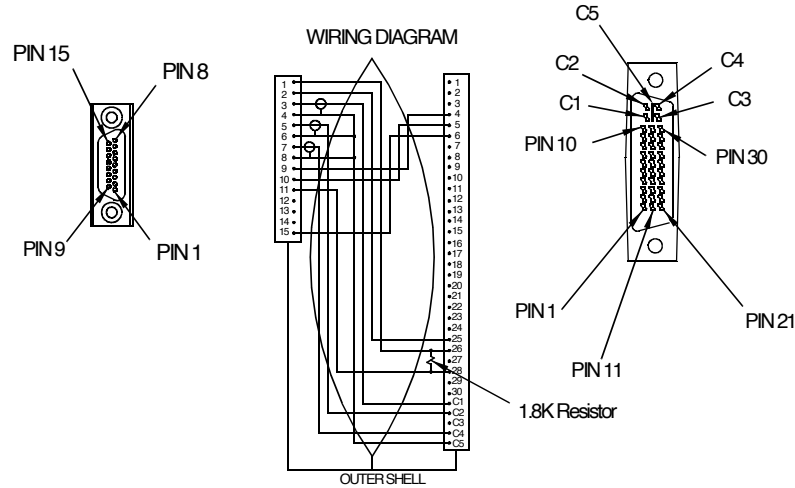
**Figure 5-3 HP A4223A Conversion Video Cable Connectors**

Table 5-3 identifies HP A4223A conversion video cable pins.

**Table 5-3 A4223A Conversion Video Cable Wiring Table**

15-Pin MDSM	15-Pin D-Sub
Pin 1	Pin 12
Pin 2	
Pin 3	Pin 1
Pin 4	Pin 6
Pin 5	Pin 2
Pin 6	Pin 7
Pin 7	Pin 3
Pin 8	Pin 8
Pin 9	Pin 10
Pin 10	Pin 13
Pin 11	Pin 9
Pin 12	
Pin 13	
Pin 14	
Pin 15	Pin 14

Figure 5-4 illustrates the connector pin locations on each end of the HP A4305A conversion video cable.



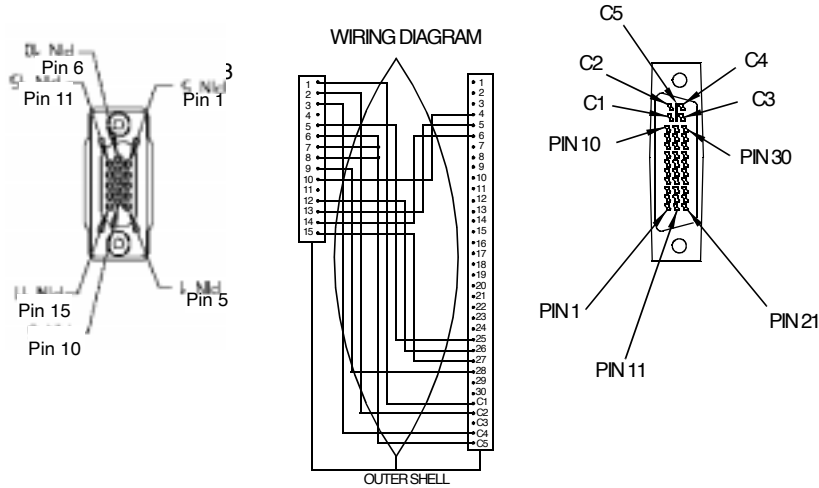
**Figure 5-4 HP A4305A Conversion Video Cable Connectors**

Table 5-4 identifies HP A4305A conversion video cable pins.

**Table 5-4 A4305A Conversion Video Cable Wiring Table**

15-Pin MDSM	35-Pin EVC
Pin 1	Pin 26
Pin 2	Pin 25
Pin 3	Pin C1
Pin 4	Pin C5
Pin 5	Pin C2
Pin 6	Pin C5
Pin 7	Pin C4
Pin 8	Pin C5
Pin 9	Pin 4
Pin 10	Pin 5
Pin 11	Pin 28
Pin 12	
Pin 13	
Pin 14	
Pin 15	Pin 6

Figure 5-5 illustrates the connector pin locations on each end of the HP A4167A conversion video cable.



**Figure 5-5 HP A4167A Conversion Video Cable Connectors**

Table 5-5 identifies HP A4167A conversion video cable pins.

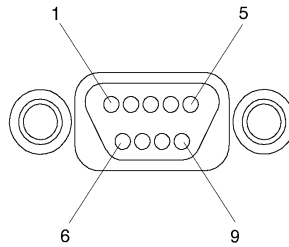
**Table 5-5 A4167A Conversion Video Cable Wiring Table**

15-Pin D-Sub	35-Pin EVC
Pin 1	Pin C1
Pin 2	Pin C2
Pin 3	Pin C4
Pin 4	
Pin 5	Pin 25
Pin 6	Pin C5
Pin 7	Pin C5
Pin 8	Pin C5
Pin 9	Pin 28
Pin 10	Pin 4
Pin 11	
Pin 12	Pin 26
Pin 13	Pin 5
Pin 14	Pin 6
Pin 15	Pin 27

### Audio Connector Pinouts

This section contains a figure of the audio connector and a table of the audio connector pinouts.

Figure 5-6 illustrates the audio connector pin locations.



**Figure 5-6** Audio Connector

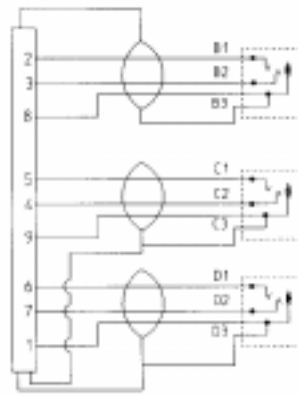
Table 5-6 identifies the audio connector pins.

**Table 5-6** Audio Connector Pinouts

Pin Number	Signal
1	Mic in GND
2	Line in left
3	Line in right
4	Headset right
5	Headset left
6	Mic in A
7	Mic Vref
8	Line in GND
9	Headset GND



Figure 5-7 illustrates the connector pin locations on each end of the HP A4302A conversion audio cable.

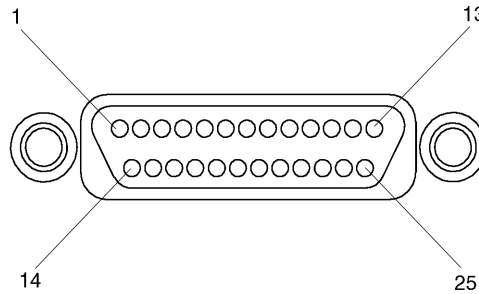


**Figure 5-7**                      **HP A4302A Conversion Audio Cable Connectors**

### HP Parallel Connector Pinouts

This section contains a figure of the HP parallel connector, a table of the HP parallel connector pinouts, the HP4300A conversion HP parallel cable connectors diagrams, and the conversion HP parallel cable wiring table.

Figure 5-8 illustrates the HP parallel connector pin locations.



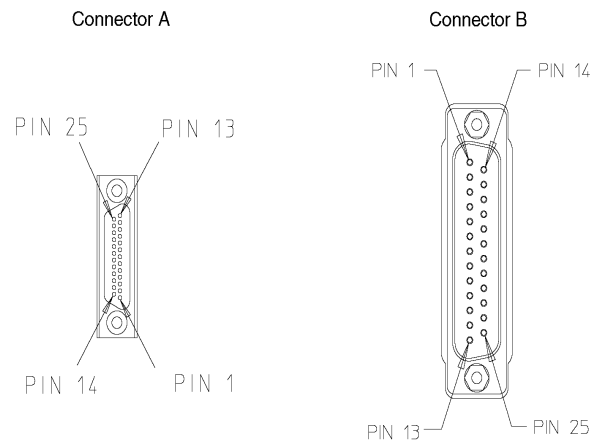
**Figure 5-8**      **HP Parallel Connector**

Table 5-7 identifies the HP parallel connector pins.

**Table 5-7**      **HP Parallel Connector Pinouts**

Pin Number	Signal	Pin Number	Signal
1	STROBE	14	AFD
2	Data 0	15	ERROR
3	Data	16	INIT
4	Data	17	SCT IN
5	Data	18	GND
6	Data	19	GND
7	Data	20	GND
8	Data	21	GND
9	Data	22	GND
10	ACK	23	GND
11	BUSY	24	GND
12	PE	25	GND
13	SLCT		

Figure 5-9 illustrates the connector pin locations on each end of the HP A4300A conversion HP parallel cable



**Figure 5-9 HP A4300A Conversion HP Parallel Cable Connectors**

Table 5-8 identifies the HP A4300A conversion HP parallel cable pins.

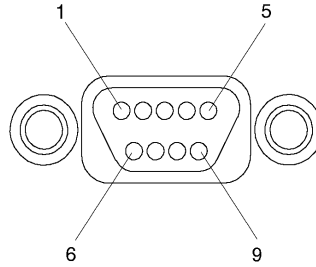
**Table 5-8 Conversion HP Parallel Cable Wiring Table**

25-Pin MDSM	25-Pin D-Sub	25-Pin MDSM	25-Pin D-Sub
Pin 1	Pin 1	Pin 14	Pin 14
Pin 2	Pin 2	Pin 15	Pin 15
Pin 3	Pin 3	Pin 16	Pin 16
Pin 4	Pin 4	Pin 17	Pin 17
Pin 5	Pin 5	Pin 18	Pin 18
Pin 6	Pin 6	Pin 19	Pin 19
Pin 7	Pin 7	Pin 20	Pin 20
Pin 8	Pin 8	Pin 21	Pin 21
Pin 9	Pin 9	Pin 22	Pin 22
Pin 10	Pin 10	Pin 23	Pin 23
Pin 11	Pin 11	Pin 24	Pin 24
Pin 12	Pin 12	Pin 25	Pin 25
Pin 13	Pin 13		

### RS-232 Connector Pinouts

This section contains a figure of the RS-232 connector, a table of the RS-232 connector pinouts, the HP 4301A conversion RS-232 cable connectors diagrams, and the conversion RS-232 cable wiring table.

Figure 5-10 illustrates the RS-232 connector pin locations.



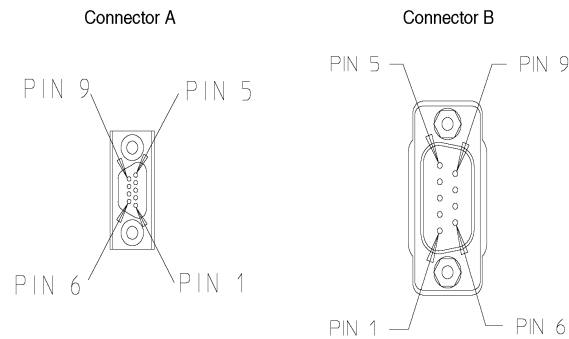
**Figure 5-10 RS-232 Serial Connector**

Table 5-9 identifies the RS-232 connector pins.

**Table 5-9 RS-232-C Connector Pinouts**

Pin Number	Signal	Pin Number	Signal
1	DCD	6	DSR
2	RXD	7	RTS
3	TXD	8	CTS
4	DTR	9	RI
5	GND		

Figure 5-11 illustrates the connector pin locations on each end of the HP A4301A conversion RS-232 cable.



**Figure 5-11 HP A4301A Conversion RS-232 Cable Connectors**

Table 5-10 is the wiring table for the HP A4301A conversion RS-232 cable.

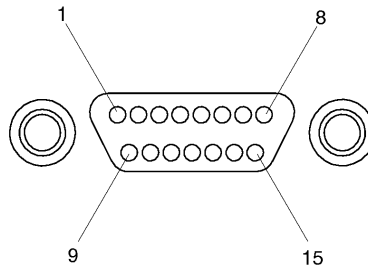
**Table 5-10 Conversion RS-232 Cable Wiring Table**

9-Pin MDSM	9-Pin D-Sub
Pin 1	Pin 1
Pin 2	Pin 2
Pin 3	Pin 3
Pin 4	Pin 4
Pin 5	Pin 5
Pin 6	Pin 6
Pin 7	Pin 7
Pin 8	Pin 8
Pin 9	Pin 9

### AUI LAN Connector Pinouts

This section contains a figure of the AUI LAN connector, a table of the AUI LAN connector pinouts, the HP 4303A conversion AUI LAN cable connectors diagrams, and the conversion AUI LAN cable wiring table.

Figure 5-12 illustrates the AUI LAN connector pin locations.



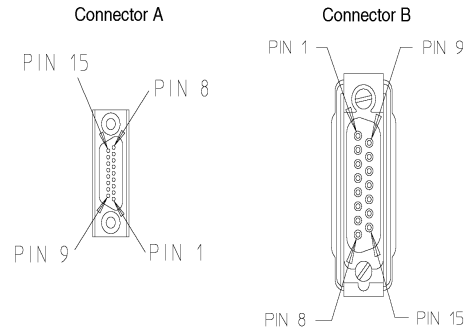
**Figure 5-12** AUI LAN Connector

Table 5-11 identifies the AUI LAN connector pins.

**Table 5-11** AUI LAN Connector Pinouts

Pin Number	Signal	Pin Number	Signal	Pin Number	Signal
1	GND	6	GND	11	DO-S (GND)
2	CI-A	7	CO-A (NC)	12	DI-B
3	DO-A	8	CO-S (NC)	13	+ 12 V
4	DI-S (GND)	9	CI-B	14	GND
5	DI-A	10	DO-B	15	CO-B (NC)

Figure 5-13 illustrates the connector pin locations on each end of the HP A4303A conversion LAN cable.



**Figure 5-13 HP A4303A Conversion LAN Cable Connectors**

Table 5-12 is the wiring table for the HP A4303A conversion LAN cable.

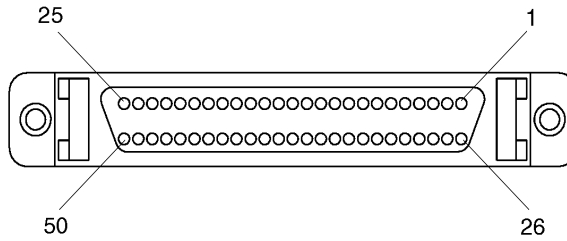
**Table 5-12 Conversion LAN Cable Wiring Table**

15-Pin MDSM	15-Pin D-Sub	15-Pin MDSM	15-Pin D-Sub
Pin 1	Pin 1	Pin 9	Pin 9
Pin 2	Pin 2	Pin 10	Pin 10
Pin 3	Pin 3	Pin 11	Pin 11
Pin 4	Pin 4	Pin 12	Pin 12
Pin 5	Pin 5	Pin 13	Pin 13
Pin 6	Pin 6	Pin 14	Pin 14
Pin 7	Pin 7	Pin 15	Pin 15
Pin 8	Pin 8		

### Single-Ended SCSI Connector Pinouts

The section that follows contains a figure of the single-ended SCSI connector and a table of the single-ended SCSI connector pinouts.

Figure 5-14 illustrates the single-ended SCSI connector pin locations.



**Figure 5-14**      **Single-Ended SCSI Connector**



Table 5-13 identifies the single-ended SCSI connector pins.

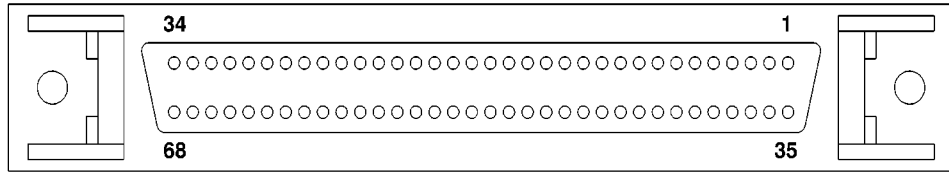
**Table 5-13 Single-Ended SCSI Connector Pinouts**

Pin Number	Signal	Pin Number	Signal
1	GND	26	DATA 0
2	GND	27	DATA 1
3	GND	28	DATA 2
4	GND	29	DATA 3
5	GND	30	DATA 4
6	GND	31	DATA 5
7	GND	32	DATA 6
8	GND	33	DATA 7
9	GND	34	Data Parity
10	GND	35	GND
11	GND	36	GND
12	GND	37	GND
13	GND	38	Term_Pwr
14	GND	39	GND
15	GND	40	GND
16	GND	41	ATN
17	GND	42	GND
18	GND	43	BSY
19	GND	44	ACK
20	GND	45	RST
21	GND	46	MSG
22	GND	47	SEL
23	GND	48	CD
24	GND	49	REQ
25	GND	50	IO

### FW SCSI Connector Pinout

The section that follows contains a figure of the FW SCSI connector and a table of the FW SCSI connector pinouts.

Figure 5-15 illustrates the FW SCSI connector pin locations.



**Figure 5-15**

### FW SCSI Connector

Table 5-14 identifies the FW SCSI connector pins.

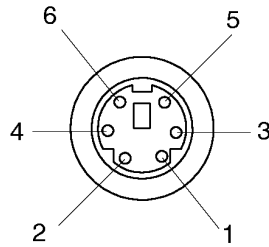
**Table 5-14 FW SCSI Connector Pinouts**

<b>Pin Number</b>	<b>Signal</b>	<b>Pin Number</b>	<b>Signal</b>
1	FW_SD12+	35	FW_SD12-
2	FW_SD13+	36	FW_SD13-
3	FW_SD14+	37	FW_SD14-
4	FW_SD15+	38	FW_SD15-
5	FW_SD1+	39	FW_SP1-
6	GND	40	GND
7	FW_SD0+	41	FW_SD0-
8	FW_SD1+	42	FW_SD1-
9	FW_SD2+	43	FW_SD2-
10	FW_SD3+	44	FW_SD3-
11	FW_SD4+	45	FW_SD4-
12	FW_SD5+	46	FW_SD5-
13	FW_SD6+	47	FW_SD6-
14	FW_SD7+	48	FW_SD7-
15	FW_SP0+	49	FW_SP0-
16	FW_DIFFSENS	50	GND
17	FW_TERM POWER	51	FW_TERM POWER
18	FW_TERM POWER	52	FW_TERM POWER
19	NC	53	NC
20	FW_SATN+	54	FW_SATN-
21	GND	55	GND
22	FW_SBSY+	56	FW_SBSY-
23	FW_SACK+	57	FW_SACK-
24	FW_SRST+	58	FW_SRST-
25	FW_SYMSG+	59	FW_SMSG-
26	FW_SSEL+	60	FW_SSEL-
27	FW_SCD+	61	FW_SCD-
28	FW_SREQ+	62	FW_SREQ-
29	FW_SIO+	63	FW_SIO-
30	GND	64	GND
31	FW_SD8+	65	FW_SD8-
32	FW_SD9+	66	FW_SD9-
33	FW_SD10+	67	FW_SD10-
34	FW_SD11+	68	FW_SD11-

### PS/2 Connector Pinouts

The following section contains a figure of the PS/2 connector and a table of the PS/2 connector pinouts.

Figure 5-16 illustrates the PS/2 connector pin locations.



**Figure 5-16** PS/2 Connector

Table 5-15 identifies the PS/2 connector pins.

**Table 5-15** PS/2 Connector Pinouts

Pin Number	Signal
1	Data
2	Not used
3	GND
4	+5
5	Clock
6	Not used

## VME Connector Pinouts

This section contains tables for the Model 743, Model 744, and the Model 748 VMEbus P1/J1 pin assignments and signal mnemonics; the Model 748 VMEbus P2/J2, slots 2-8, pin assignments and signal mnemonics; the Model 743 and Model 744 VMEbus P2/J2, slot 1 pin assignments and signal mnemonics. Slot 1 in the Model 748 is reserved for the Model 743 and 744 CPU boards.

Table 5-16 identifies the VMEbus connector pin assignments and signal mnemonics for the Model 743, Model 744, and the Model 748 VME P1/J1.

**Table 5-16 Model 743 and 744/Model 748 VME P1/J1 Pin Assignments and Signal Mnemonics**

Pin Number	Row A	Row B	Row C
1	D00	BBSY	D08
2	D01	BCLR	D09
3	D02	ACFAIL	D10
4	D03	BG0IN	D11
5	D04	BG0OUT	D12
6	D05	BG1IN	D13
7	D06	BG1OUT	D14
8	D07	BG2IN	D15
9	GROUND	BG2OUT	GROUND
10	SYSCLOCK	BG3IN	SYSFAIL
11	GROUND	BG3OUT	BERR
12	DS1	BR0	SYSRESET
13	DS0	BR1	LWORD
14	WRITE	BR2	AM5
15	GND	BR3	A23
16	DTACK	AM0	A22
17	GND	AM1	A21
18	AM2	AM2	A20
19	AM3	AM3	A19
20	GND	GND	A18
21	IACKIN	NC	A17
22	IACKOUT	NC	A16
23	AM4	GND	A15
24	A07	IRQ7	A14
25	A06	IRQ6	A13
26	A05	IRQ5	A12
27	A04	IRQ4	A11
28	A03	IRQ3	A10
29	A02	IRQ2	A09
30	A01	IRQ1	A08
31	-12Vdc	NC	+12Vdc
32	+5Vdc	+5Vdc	+5Vdc

Table 5-17 identifies the VMEbus connector pin assignments and signal mnemonics for the Model 748 VME P2/J2, slots 2 - 8.

Table 5-17

**Model 748 VME P2/J2 Pin Assignments and Signal Mnemonics**

Pin Number	Row A	Row B	Row C
1	User defined	+5Vdc	User defined
2	User defined	GND	User defined
3	User defined	Reserved	User defined
4	User defined	A24	User defined
5	User defined	A25	User defined
6	User defined	A26	User defined
7	User defined	A27	User defined
8	User defined	A28	User defined
9	User defined	A29	User defined
10	User defined	A30	User defined
11	User defined	A31	User defined
12	User defined	GND	User defined
13	User defined	+5Vdc	User defined
14	User defined	D16	User defined
15	User defined	D17	User defined
16	User defined	D18	User defined
17	User defined	D19	User defined
18	User defined	D20	User defined
19	User defined	D21	User defined
20	User defined	D22	User defined
21	User defined	D23	User defined
22	User defined	GND	User defined
23	User defined	D24	User defined
24	User defined	D25	User defined
25	User defined	D26	User defined
26	User defined	D27	User defined
27	User defined	D28	User defined
28	User defined	D29	User defined
29	User defined	D30	User defined
30	User defined	D31	User defined
31	User defined	GND	User defined
32	User defined	+5Vdc	User defined

Table 5-18 identifies the VMEbus connector pin assignments and signal mnemonics for the Model 743 P2.

**Table 5-18 Model 743 P2/J2 Pin Assignments and Signal Mnemonics - Slot 1**

Pin Number	Row A	Row B	Row C
1	SYNCL	+5Vdc	GSC_AD[0]
2	SYNCH	GND	GSC_AD[1]
3	NC	Reserved	GSC_AD[2]
4	RESET_L	A24	GSC_AD[3]
5	NC	A25	GSC_AD[4]
6	GSC_BR_L	A26	GSC_AD[5]
7	GSC_BG_L	A27	GSC_AD[6]
8	NC	A28	GSC_AD[7]
9	GSC_ADDV_L	A29	GSC_AD[8]
10	GSC_READY_L	A30	GSC_AD[9]
11	NC	A31	GSC_AD[10]
12	GSC_ERROR_L	GND	GSC_AD[11]
13	GSC_PARITY_L	+5Vdc	GSC_AD[12]
14	GSC_XQ_L	D16	GSC_AD[13]
15	GSC_LS_L	D17	GSC_AD[14]
16	NC	D18	GSC_AD[15]
17	GSC_TYPE[0]	D19	GSC_AD[16]
18	GSC_TYPE[1]	D20	GSC_AD[17]
19	GSC_TYPE[2]	D21	GSC_AD[18]
20	GSC_TYPE[3]	D22	GSC_AD[19]
21	NC	D23	GSC_AD[20]
22	SYNCTTL	GND	GSC_AD[21]
23	SP_DETECT	D24	GSC_AD[22]
24	ALT_BR_L	D25	GSC_AD[23]
25	ALT_BG_L	D26	GSC_AD[24]
26	NC	D27	GSC_AD[25]
27	NC	D28	GSC_AD[26]
28	TDO	D29	GSC_AD[27]
29	TDI	D30	GSC_AD[28]
30	TCK	D31	GSC_AD[29]
31	TMS	GND	GSC_AD[30]
32	TRST	+5Vdc	GSC_AD[31]



Table 5-19 identifies the VMEbus connector pin assignments and signal mnemonics for the Model 744 VME P2.

**Table 5-19 Model 744 VME P2 Pin Assignments and Signal Mnemonics**

Pin Number	Row A	Row B	Row C
1	SYNCHWAXL	+5 V	GSC_AD0
2	SYNCHWAXH	GND	GSC_AD1
3	NC	Reserved	GSC_AD2
4	WAX_RST_L	VME_A24	GSC_AD3
5	NC	VME_A25	GSC_AD4
6	GSC_BR_L(2)	VME_A26	GSC_AD5
7	GSC_BG_L(2)	VME_A27	GSC_AD6
8	NC	VME_A28	GSC_AD7
9	GSC_ADDV_L	VME_A29	GSC_AD8
10	GSC_READY_L	VME_A30	GSC_AD9
11	NC	VME_A31	GSC_AD10
12	GSC_ERROR_L	GND	GSC_AD11
13	GSC_PARITY_L	+5 V	GSC_AD12
14	GSC_XQ_L	VME_D16	GSC_AD13
15	GSC_LS_L	VME_D17	GSC_AD14
16	NC	VME_D18	GSC_AD15
17	GSC_TYPE0	VME_D19	GSC_AD16
18	GSC_TYPE1	VME_D20	GSC_AD17
19	GSC_TYPE2	VME_D21	GSC_AD18
20	GSC_TYPE3	VME_D22	GSC_AD19
21	NC	VME_D23	GSC_AD20
22	SYNCTTL	GND	GSC_AD21
23	SP_DETECT	VME_D24	GSC_AD22
24	ALT_BR_L	VME_D25	GSC_AD23
25	ALT_BG_L	VME_D26	GSC_AD24
26	NC	VME_D27	GSC_AD25
27	NC	VME_D28	GSC_AD26
28	TDO	VME_D29	GSC_AD27
29	TDI	VME_D30	GSC_AD28
30	TCK	VME_D31	GSC_AD29
31	TMS	GND	GSC_AD30

**Table 5-19 Model 744 VME P2 Pin Assignments and Signal Mnemonics**

Pin Number	Row A	Row B	Row C
32	TRST	+5 V	GSC_AD31

Table 5-29 identifies the PMC JN1 signals on the PMC Bridge J21 connectors.

**Table 5-20 PMC JN1 Signals (Bridge J21)**

Pin Number	Signal	Pin Number	Signal
1	TCK	2	-12V
3	Ground	4	INTC
5	INTB#	6	INTA
7	BUSMODE1#	8	+5V
9	INTD#	10	PCI-RESERVED
11	Ground	12	PCI-RESERVED
13	CLK	14	Ground
15	Ground	16	GNTB#
17	REQB#	18	+5V
19	VDD(I/O)	20	AD31
21	AD28	22	AD27
23	AD25	24	Ground
25	Ground	26	C/BE3#
27	AD22	28	AD21
29	AD19	30	+5V
31	VDD(I/O)	32	AD17
33	FRAME#	34	Ground
35	Ground	36	IRDY#
37	DEVSEL#	38	+5V
39	Ground	40	LOCK#
41	SDONE#	42	SBO#
43	PAR	44	Ground
45	VDD(I/O)	46	AD15
47	AD12	48	AD11
49	AD09	50	+5V
51	Ground	52	C/BE0#
53	AD06	54	AD05
55	AD04	56	Ground

**Table 5-20**      **PMC JN1 Signals (Bridge J21)**

Pin Number	Signal	Pin Number	Signal
57	VDD(I/O)	58	AD03
59	AD02	60	AD01
61	AD00	62	+5V
63	Ground	64	REQ64#

Table 5-29 identifies the PMC JN2 signals on the PMC Bridge J22 connectors.

**Table 5-21**      **PMC JN2 Signals (Bridge J22)**

Pin Number	Signal	Pin Number	Signal
1	+12V	2	TRST#
3	TMS	4	TDO
5	TDI	6	Ground
7	Ground	8	PCI-RESERVED
9	PCI-RESERVED	10	PCI-RESERVED
11	BUSMODE2#	12	+3.3V
13	RST	14	BUSMODE3
15	+3.3V	16	BUSMODE4
17	PCI-RESERVED	18	Ground
19	AD30	20	AD29
21	Ground	22	AD26
23	AD24	24	+3.3V
25	IDSEL(1)	26	AD23
27	+3.3V	28	AD20
29	AD18	30	Ground
31	AD16	32	C/BE2#
33	Ground	34	PMC-RSVD
35	TRDY#	36	+3.3V
37	Ground	38	STOP#
39	PERR#	40	Ground
41	+3.3V	42	SERR#
43	C/BE1#	44	Ground
45	AD14	46	AD13
47	Ground	48	AD10
49	AD08	50	+3.3V

**Table 5-21**      **PMC JN2 Signals (Bridge J22)**

Pin Number	Signal	Pin Number	Signal
51	AD07	52	PMC-RSVD
53	+3.3V	54	PMC-RSVD
55	PMC-RSVD	56	Ground
57	PMC-RSVD	58	PMC-RSVD
59	Ground	60	PMC-RSVD
61	ACK64#	62	+3.3V
63	Ground	64	PMC-RSVD

Table 5-28 identifies the PMC JN1 signals on the PMC Bridge J11 connectors.

**Table 5-22**      **PMC JN1 Signals (Bridge J11)**

Pin Number	Signal	Pin Number	Signal
1	TCK	2	-12V
3	Ground	4	INTB
5	INTC#	6	INTD
7	BUSMODE1#	8	+5V
9	INTA#	10	PCI-RESERVED
11	Ground	12	PCI-RESERVED
13	CLK	14	Ground
15	Ground	16	GNTA#
17	REQA#	18	+5V
19	VDD(I/O)	20	AD31
21	AD28	22	AD27
23	AD25	24	Ground
25	Ground	26	C/BE3#
27	AD22	28	AD21
29	AD19	30	+5V
31	VDD(I/O)	32	AD17
33	FRAME#	34	Ground
35	Ground	36	IRDY#
37	DEVSEL#	38	+5V
39	Ground	40	LOCK#
41	SDONE#	42	SBO#
43	PAR	44	Ground

**Table 5-22**      **PMC JN1 Signals (Bridge J11)**

Pin Number	Signal	Pin Number	Signal
45	VDD(I/O)	46	AD15
47	AD12	48	AD11
49	AD09	50	+5V
51	Ground	52	C/BE0#
53	AD06	54	AD05
55	AD04	56	Ground
57	VDD(I/O)	58	AD03
59	AD02	60	AD01
61	AD00	62	+5V
63	Ground	64	REQ64#

Table 5-29 identifies the PMC JN2 signals on the PMC Bridge J12 connectors.

**Table 5-23**      **PMC JN2 Signals (Bridge J12)**

Pin Number	Signal	Pin Number	Signal
1	+12V	2	TRST#
3	TMS	4	TDO
5	TDI	6	Ground
7	Ground	8	PCI-RESERVED
9	PCI-RESERVED	10	PCI-RESERVED
11	BUSMODE2#	12	+3.3V
13	RST	14	BUSMODE3
15	+3.3V	16	BUSMODE4
17	PCI-RESERVED	18	Ground
19	AD30	20	AD29
21	Ground	22	AD26
23	AD24	24	+3.3V
25	IDSEL(2)	26	AD23
27	+3.3V	28	AD20
29	AD18	30	Ground
31	AD16	32	C/BE2#
33	Ground	34	PMC-RSVD
35	TRDY#	36	+3.3V
37	Ground	38	STOP#

**Table 5-23**      **PMC JN2 Signals (Bridge J12)**

Pin Number	Signal	Pin Number	Signal
39	PERR#	40	Ground
41	+3.3V	42	SERR#
43	C/BE1#	44	Ground
45	AD14	46	AD13
47	Ground	48	AD10
49	AD08	50	+3.3V
51	AD07	52	PMC-RSVD
53	+3.3V	54	PMC-RSVD
55	PMC-RSVD	56	Ground
57	PMC-RSVD	58	PMC-RSVD
59	Ground	60	PMC-RSVD
61	ACK64#	62	+3.3V
63	Ground	64	PMC-RSVD

Table 5-25 identifies the PMC JN4 User Defined pin outs on the PMC Bridge J14 connector that is wired to the VME backplane P2 connector.

**Table 5-24**      **PMC JN4 Pin Outs (Bridge J14)**

Pin Number	Signal	Pin Number	Signal
1	P2-C1	2	P2-A1
3	P2-C2	4	P2-A2
5	P2-C3	6	P2-A3
7	P2-C4	8	P2-A4
9	P2-C5	10	P2-A5
11	P2-C6	12	P2-A6
13	P2-C7	14	P2-A7
15	P2-C8	16	P2-A8
17	P2-C9	18	P2-A9
19	P2-C10	20	P2-A10
21	P2-C11	22	P2-A11
23	P2-C12	24	P2-A12
25	P2-C13	26	P2-A13
27	P2-C14	28	P2-A14
29	P2-C15	30	P2-A15

**Table 5-24**      **PMC JN4 Pin Outs (Bridge J14)**

Pin Number	Signal	Pin Number	Signal
31	P2-C16	32	P2-A16
33	P2-C17	34	P2-A17
35	P2-C18	36	P2-A18
37	P2-C19	38	P2-A19
39	P2-C20	40	P2-A20
41	P2-C21	42	P2-A21
43	P2-C22	44	P2-A22
45	P2-C23	46	P2-A23
47	P2-C24	48	P2-A24
49	P2-C25	50	P2-A25
51	P2-C26	52	P2-A26
53	P2-C27	54	P2-A27
55	P2-C28	56	P2-A28
57	P2-C29	58	P2-A29
59	P2-C30	60	P2-A30
61	P2-C31	62	P2-A31
63	P2-C32	64	P2-A32

Table 5-25 identifies the PMC Bridge J3 connector that routes signals from the bridge board to the PMC expander board.

**Table 5-25**      **PMC Bridge J3 Connector**

Pin Number	Signal	Pin Number	Signal	Pin Number	Signal
1	SYNC-EXPI	39	GSC-AD23	114	PCI-STOP-L
2	GSC-READY-L	40	GSC-AD24	115	PCI-AD0
3	GSC-RESET-L	41	GSC-AD25	116	PCI-AD1
4	GSC-ADDV-L	42	GSC-AD26	117	PCI-AD2
5	SYNC-EXPI-L	43	GSC-AD27	118	PCI-AD3
6	GSC-BR-L	44	GSC-AD28	119	PCI-AD4
7	GSC-BG-L	45	GSC-AD29	120	PCI-AD5
8	GSC-INTR-L	46	GSC-AD30	121	PCI-AD6
9	GSC-ERROR-L	47	GSC-AD31	122	PCI-AD7
10	GSC-PARITY	48	GSC-TYPE0	123	PCI-AD8
11	GSC-XO-L	49	GSC-TYPE1	124	PCI-AD9
12	GSC-LS-L	50	GSC-TYPE2	125	PCI-AD10
13	TRSTL	51	GSC-TYPE3	126	PCI-AD11
14	TMS	52	VDL	127	PCI-AD12
15	VDL	53	VDL	128	PCI-AD13

**Table 5-25**      **PMC Bridge J3 Connector**

Pin Number	Signal	Pin Number	Signal	Pin Number	Signal
16	GSC-AD0	54	VDL	129	PCI-AD14
17	GSC-AD1	55	VDL	130	PCI-AD15
18	GSC-AD2	56	VDL	131	PCI-AD16
19	GSC-AD3	57	VDL	132	PCI-AD17
20	GSC-AD4	58-95	No connect	133	PCI-AD18
21	GSC-AD5	96	PCI-RST-L	134	PCI-AD19
22	GSC-AD6	97	PCI-SL3-CLK	135	PCI-AD20
23	GSC-AD7	98	PCI-FRAME-L	136	PCI-AD21
24	GSC-AD8	99	PCI-SL4-CLK	137	PCI-AD22
25	GSC-AD9	100	PCI-CBEO	138	PCI-AD23
26	GSC-AD10	101	PCI-CBE1	139	PCI-AD24
27	GSC-AD11	102	PCI-CBE2	140	PCI-AD25
28	GSC-AD12	103	PCI-CBE3	141	PCI-AD26
29	GSC-AD13	104	PCI-SERR-L	142	PCI-AD27
30	GSC-AD14	105	PCI-PERR-L	143	PCI-AD28
31	GSC-AD15	106	PCI-PAR	144	PCI-AD29
32	GSC-AD16	107	PCI-REQC-L	144	PCI-AD30
33	GSC-AD17	108	PCI-GNTC-L	146	PCI-AD31
34	GSC-AD18	109	PCI-REQD-L	147	PCI-INTA-L
35	GSC-AD19	110	PCI-GNTD-L	148	PCI-INTB-L
36	GSC-AD20	111	PCI-TRDY-L	149	PCI-INTC-L
37	GSC-AD21	112	PCI-IRDY-L	150	PCI-INTD-L
38	GSC-AD22	113	PCI-LOCK-L	151	PCI-DEVSEL-L
				152	VDL

Table 5-26 identifies the PMC JN1 signals on the PMC Expander J31 connectors.

**Table 5-26**      **PMC JN1 Signals (Expander J31)**

Pin Number	Signal	Pin Number	Signal
1	TCK	2	-12V
3	Ground	4	INTD
5	INTA#	6	INTB
7	BUSMODE1#	8	+5V
9	INTC#	10	PCI-RESERVED
11	Ground	12	PCI-RESERVED
13	CLK	14	Ground
15	Ground	16	GNTC#



**Table 5-26**      **PMC JN1 Signals (Expander J31)**

Pin Number	Signal	Pin Number	Signal
17	REQC#	18	+5V
19	VDD(I/O)	20	AD31
21	AD28	22	AD27
23	AD25	24	Ground
25	Ground	26	C/BE3#
27	AD22	28	AD21
29	AD19	30	+5V
31	VDD(I/O)	32	AD17
33	FRAME#	34	Ground
35	Ground	36	IRDY#
37	DEVSEL#	38	+5V
39	Ground	40	LOCK#
41	SDONE#	42	SBO#
43	PAR	44	Ground
45	VDD(I/O)	46	AD15
47	AD12	48	AD11
49	AD09	50	+5V
51	Ground	52	C/BE0#
53	AD06	54	AD05
55	AD04	56	Ground
57	VDD(I/O)	58	AD03
59	AD02	60	AD01
61	AD00	62	+5V
63	Ground	64	REQ64#

Table 5-27 identifies the PMC JN2 signals on the PMC Expander J32 connectors.

**Table 5-27**      **PMC JN2 Signals (Expander J32)**

Pin Number	Signal	Pin Number	Signal
1	+12V	2	TRST#
3	TMS	4	TDO
5	TDI	6	Ground
7	Ground	8	PCI-RESERVED
9	PCI-RESERVED	10	PCI-RESERVED

Table 5-27

PMC JN2 Signals (Expander J32)

Pin Number	Signal	Pin Number	Signal
11	BUSMODE2#	12	+3.3V
13	RST	14	BUSMODE3
15	+3.3V	16	BUSMODE4
17	PCI-RESERVED	18	Ground
19	AD30	20	AD29
21	Ground	22	AD26
23	AD24	24	+3.3V
25	IDSEL(3)	26	AD23
27	+3.3V	28	AD20
29	AD18	30	Ground
31	AD16	32	C/BE2#
33	Ground	34	PMC-RSVD
35	TRDY#	36	+3.3V
37	Ground	38	STOP#
39	PERR#	40	Ground
41	+3.3V	42	SERR#
43	C/BE1#	44	Ground
45	AD14	46	AD13
47	Ground	48	AD10
49	AD08	50	+3.3V
51	AD07	52	PMC-RSVD
53	+3.3V	54	PMC-RSVD
55	PMC-RSVD	56	Ground
57	PMC-RSVD	58	PMC-RSVD
59	Ground	60	PMC-RSVD
61	ACK64#	62	+3.3V
63	Ground	64	PMC-RSVD

Table 5-28 identifies the PMC JN1 signals on the PMC Expander J41 connectors.

Table 5-28

PMC JN1 Signals (Expander J41)

Pin Number	Signal	Pin Number	Signal
1	TCK	2	-12V
3	Ground	4	INTA

**Table 5-28**      **PMC JN1 Signals (Expander J41)**

<b>Pin Number</b>	<b>Signal</b>	<b>Pin Number</b>	<b>Signal</b>
5	INTB#	6	INTC
7	BUSMODE1#	8	+5V
9	INTD#	10	PCI-RESERVED
11	Ground	12	PCI-RESERVED
13	CLK	14	Ground
15	Ground	16	GNTD#
17	REQD#	18	+5V
19	VDD(I/O)	20	AD31
21	AD28	22	AD27
23	AD25	24	Ground
25	Ground	26	C/BE3#
27	AD22	28	AD21
29	AD19	30	+5V
31	VDD(I/O)	32	AD17
33	FRAME#	34	Ground
35	Ground	36	IRDY#
37	DEVSEL#	38	+5V
39	Ground	40	LOCK#
41	SDONE#	42	SBO#
43	PAR	44	Ground
45	VDD(I/O)	46	AD15
47	AD12	48	AD11
49	AD09	50	+5V
51	Ground	52	C/BE0#
53	AD06	54	AD05
55	AD04	56	Ground
57	VDD(I/O)	58	AD03
59	AD02	60	AD01
61	AD00	62	+5V
63	Ground	64	REQ64#

Table 5-29 identifies the PMC JN2 signals on the PMC Expander J42 connectors.

**Table 5-29**      **PMC JN2 Signals (Expander J42)**

Pin Number	Signal	Pin Number	Signal
1	+12V	2	TRST#
3	TMS	4	TDO
5	TDI	6	Ground
7	Ground	8	PCI-RESERVED
9	PCI-RESERVED	10	PCI-RESERVED
11	BUSMODE2#	12	+3.3V
13	RST	14	BUSMODE3
15	+3.3V	16	BUSMODE4
17	PCI-RESERVED	18	Ground
19	AD30	20	AD29
21	Ground	22	AD26
23	AD24	24	+3.3V
25	IDSEL4)	26	AD23
27	+3.3V	28	AD20
29	AD18	30	Ground
31	AD16	32	C/BE2#
33	Ground	34	PMC-RSVD
35	TRDY#	36	+3.3V
37	Ground	38	STOP#
39	PERR#	40	Ground
41	+3.3V	42	SERR#
43	C/BE1#	44	Ground
45	AD14	46	AD13
47	Ground	48	AD10
49	AD08	50	+3.3V
51	AD07	52	PMC-RSVD
53	+3.3V	54	PMC-RSVD
55	PMC-RSVD	56	Ground
57	PMC-RSVD	58	PMC-RSVD
59	Ground	60	PMC-RSVD
61	ACK64#	62	+3.3V
63	Ground	64	PMC-RSVD

## Real-Time Clock (RTC) Battery Information

The following section contains information on the real-time clock battery.

### Battery Specifications

Table 5-30 summarizes the RTC battery specifications.

**Table 5-30**

### RTC Battery Specifications

Type	Voltage	Manufacturer	Manufacturer Part No	HP Part No.	Battery Life Power Off	Battery Life Power On
Lithium	3 Vdc	Panasonic (743) RAYOVAC (744)	BR-1616 (743) BR-1225 (744)	1420-0525 (743) 1420-0541 (744)	.5 Yr (743) 1 Yr (744)	10 Years

---

**WARNING:**

**Danger of explosion if battery is incorrectly replaced.**

**Replace only with the same or equivalent type recommended by the manufacturer.  
Dispose of used batteries according to the manufacturer's instructions.**

---

### Video Output Signal Specifications

The following input signal specifications are typical for all HP monitors:

- Output connector - 15-pin MDSM
- Impedance - 75 ohms Signal levels -
- Signal levels follow EIA standard RS-343A; white is positive. The composite sync is supplied on the green signal only. Horizontal sync pulses do not need to be supplied during the vertical sync pulse. However, the 75 Hz VESA-standard timing should use separate TTL horizontal and vertical syncs. Sync-on-green should not be supplied simultaneously with the separate syncs.

### Video Timing Specifications

This section contains information on video timing specifications. These specifications are not the output timing specifications for any particular graphics option. They are the input specifications for Hewlett-Packard monitors.

Table 5-31 summarizes the timing specifications for the 1024 x 768 and 1280 x 1024 monitors at 60 Hz, 75 Hz, and 72 Hz.

**Table 5-31 Timing Specifications at 60 Hz, 75 Hz, and 72 Hz**

Signal	D2806A 1024x768 60 Hz	D2806A 1024x768 75 Hz	A4330A/ A4331 1280x1024 60Hz	A4330A/ A4331 1280x1024 72 Hz
Horizontal active scan	15.97µs	12.105µs	11.832µs	9.482µs
Horizontal “back porch”	2.00µs	1.513µs	1.849µs	1.422µs
Horizontal blanking	4.99µs	3.783µs	3.956µs	3.318µs
Horizontal “front porch”	1.00µs	0.756µs	0.407µs	0.474µs
Horizontal period (“1H”)	20.96µs	15.888µs	15.788µs	12.800µs
Horizontal sweep frequency	47.7KHz	62.936KHz	63.34KHz	78.125KHz
Horizontal sync width	2.00µs	1.513µs	1.701µs	1.422µs
Pixel clock rate	64.1088MHz	84.587MHz	108.181MHz	135.000MHz
Vertical active period	16.097ms	12.202ms	16.167ms	13.107ms
Vertical “back porch”	419.20µs (20H)	1.016ms (64H)	410.49 µs (26H)	704.00µs (55H)
Vertical blanking	0.570ms	1.144ms	.505ms	0.780ms
Vertical frame rate	60Hz (non-in)	74.924Hz (non-in)	60Hz (non-in)	72.005Hz (non-in)
Vertical “front porch”	62.89µs (3H)	63.55µs (4H)	47.36µs (3H)	38.400µs (3H)
Vertical period	16.667ms	13.346ms	16.672ms	13.887ms
Vertical sync width	83.86µs (4H)	63.55µs (4H)	47.36µs (3H)	38.400µs (3H)

Table 5-32 summarizes the timing specifications for the 1024 x 768 and 1280 x 1024 monitors at VESA 75 Hz standard.

**Table 5-32 Timing Specifications for VESA 75 HZ Standard**

<b>Signal</b>	<b>D2806A 1024x768 75 Hz VESA</b>	<b>A4330A/A4331 1280x1024 75 Hz VESA</b>
Horizontal active scan	13.003 $\mu$ s	9.481 $\mu$ s
Horizontal "back porch"	2,235 $\mu$ s	1.837 $\mu$ s
Horizontal blanking	3.367 $\mu$ s	3.022 $\mu$ s
Horizontal "front porch"	0.203 $\mu$ s	0.119 $\mu$ s
Horizontal period ("1H")	16.660 $\mu$ s	12.504 $\mu$ s
Horizontal sweep frequency	60.023KHz	79.976KHz
Horizontal sync width	1.219 $\mu$ s	1.067 $\mu$ s
Pixel clock rate	78.750 MHz	135.000Mhz
Vertical active period	12.795ms	12.804ms
Vertical "back porch"	466.48 $\mu$ s	475.15 $\mu$ s
Vertical blanking	0.533ms	0.525ms
Vertical frame rate	75.029Hz (non-in)	75.025Hz (non-in)
Vertical "front porch"	16.66 $\mu$ s (1H)	13.000 $\mu$ s (1H)
Vertical period	13.328ms	13.329ms
Vertical sync width	49.98 $\mu$ s (3H)	37.520 $\mu$ s (3H)

In the past, Hewlett-Packard workstation timing was set with sync-on-green. The VESA standard provides separate TTL syncs, thereby providing an unambiguous way for the monitor to distinguish them.





---

## **Power Requirements**

This chapter discusses power distribution, monitor ac power specifications, and power budgeting.

## Power Distribution

The VMEbus chassis connectors P1 and P2 distribute power to the Model 743 and Model 744 board computer's PC boards as follows:

Graphics cards receive power through the adapter board's P1 and P2 connectors. RAM cards receive power through the RAM stack connectors. The system board and RAM card receive power through the system board's P1 and P2 connectors.

**NOTE:**

VME P1 and P2 connectors use two or more pins to carry power or grounds to the board computer. Check the VME P1 and P2 pinout tables for exact pin identification for power and grounds.

Figure 6-1 and Figure 6-2 illustrate the power distribution for the Model 743 and Model 744 VMEbus board computers. Figure 6-3 and Figure 6-4 illustrate the power distribution for the GSC expansion adapter and the PMC adapters.

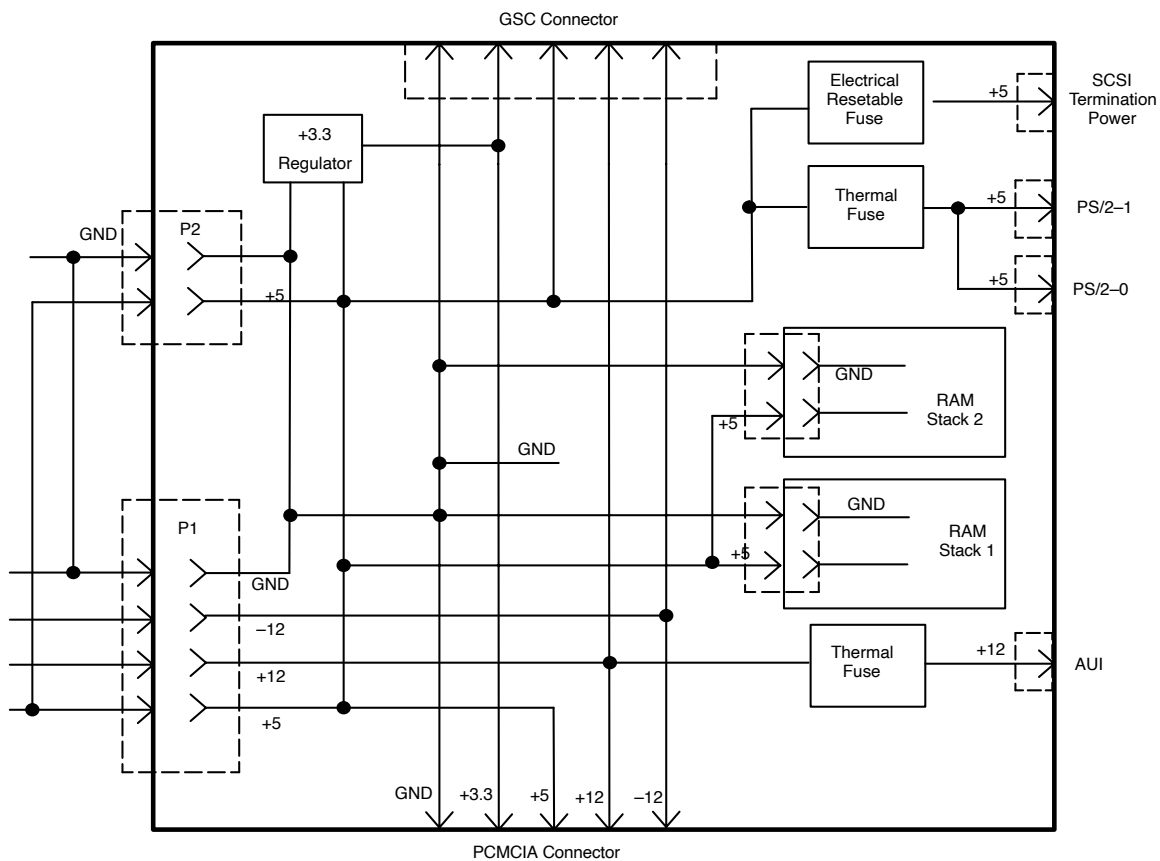


Figure 6-1 Model 743 Board Computer Power Distribution Diagram

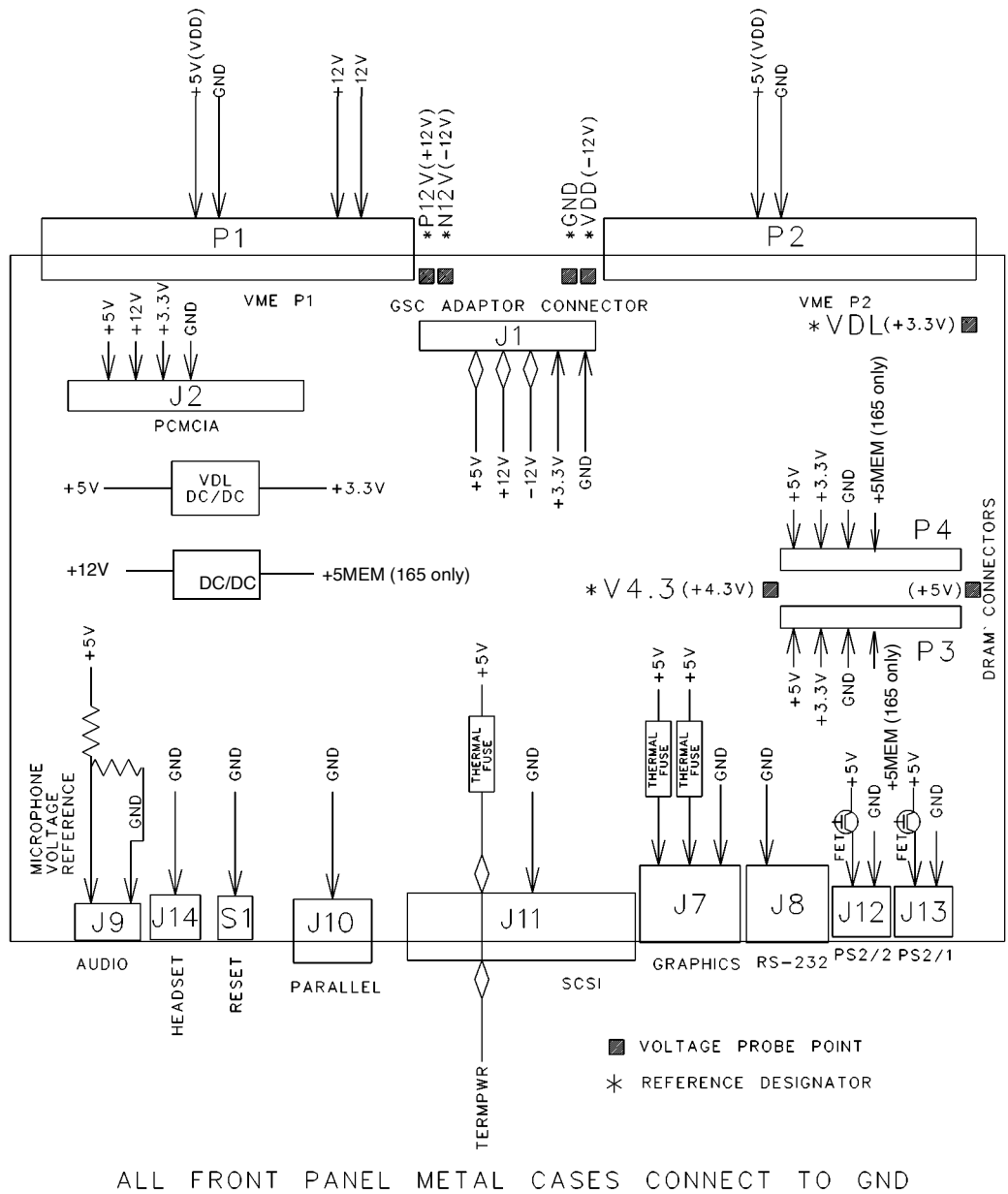


Figure 6-2 Model 744 Board Computer Power Distribution Diagram

Power Requirements  
Power Distribution

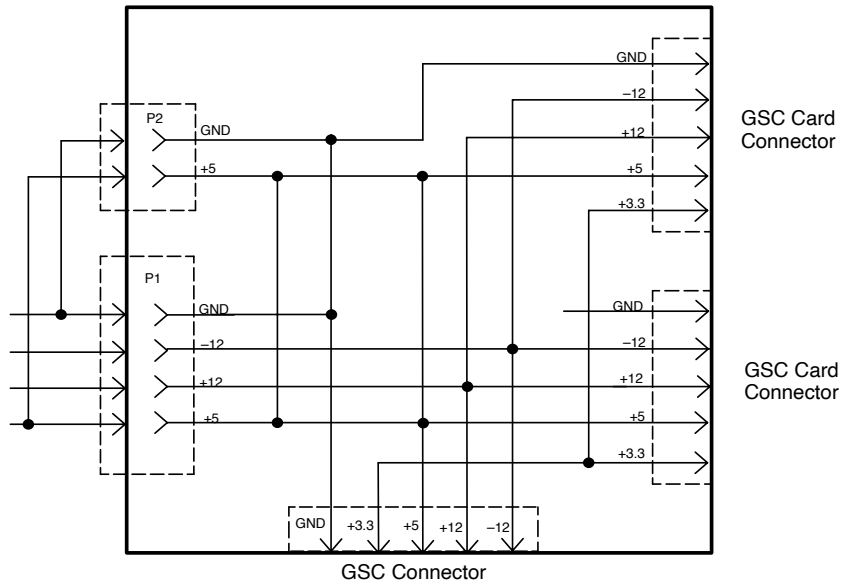


Figure 6-3 GSC Expansion Adapter Power Distribution

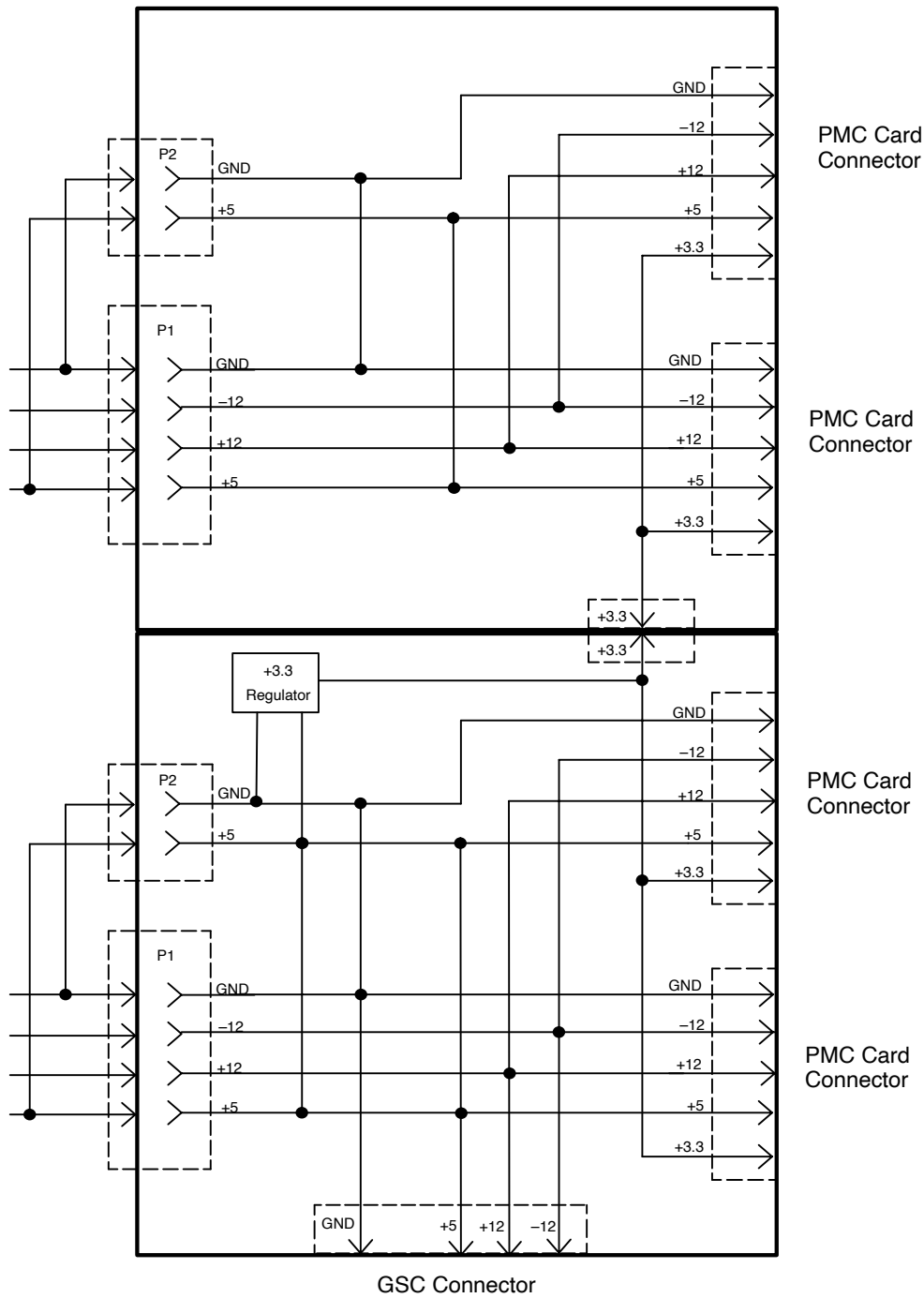


Figure 6-4 PMC Adapters Power Distribution

### FW SCSI Estimated Power Consumption

Table 6-1 summarizes the estimated power consumption of the FW SCSI adapter.

**Table 6-1 FW SCSI Power Dissipation**

HW Component	+5 V Current (VDD0)	+3 V Current (SYS_VDL)	+12 V Current	-12 V Current	P-total
SCSI terminators <sup>a</sup>	213 mA	0	0	0	1.07 W
Total <sup>b</sup>	698 mA	1.2 mA	0	0	3.50 W

a. On-board SCSI terminators; all signals asserted.

b. Actual power demand is greater due to the requirement of supplying SCSI bus TERM power. This value is limited to 2 A by an on-board fuse. The total power demand could be as high as 12.43 W.

### Monitor Power Specifications

The following section describes the ac power specifications for the 17-inch and 20-inch monitors.

Table 6-2 summarizes the ac power specifications.

**Table 6-2 Monitor Power Specifications**

Voltage Type	60 Hz	50 Hz
Maximum operating (Vac)	132	288
Minimum operating (Vac)	90	198
Nominal rated (Vac)	110	230
Rated line current (Arms)	2.7	1.5
Frequency range (not-strappable)	47 Hz to 63 Hz	47 Hz to 63 Hz

## Power Budgeting

If your workstation's application requires several accessory cards and mass storage devices, power budgeting may be required. Power budgeting ensures that the power needed for the following internal devices does not exceed the power available:

- Mass storage devices
- Model 743 and Model 744 VMEbus Board Computer(s)
- Standard internal printed circuit boards
- PCI, PMC, VME, or EISA accessory cards

The Model 748 ruggedized workstation uses two power supplies. Each power supply provides voltages to the workstation's modules and accessory card slots as listed in Table 6-8 and Table 6-9.

These tables are also worksheets to use in determining your power budget. You may photocopy these tables as needed.

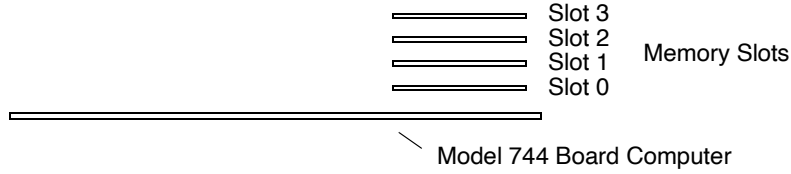
To determine the workstation's power needs, follow these instructions:

- 1 Determine the board computer's current requirements from the Computer Current Requirements Worksheet (Table 6-5 or Table 6-6).
- 2 To determine the maximum current usage of the Model 744 memory cards, use Figure 6-5 and Table 6-3 (for Model 744/132L) or Table 6-4 (for Model 744/165L). **Note that some memory cards draw current from +12V on the Model 744/165L.** This is because +12 is converted to +5MEM for the 16MB, 32MB, and 64MB cards (see Figure 6-2). You must work with the worst case power draw to correctly determine power usage. Determine worst case power draw by examining active memory bank configurations, using the following steps:
  - a Examine your memory card configuration, noting which size card is in each memory slot.
  - b The worst case active memory bank configuration depends on the slot position of the memory cards, and the size of the cards. The 32 MB memory card has two banks per card, and the 16, 64, 128, and 256 MB cards each have only one memory bank per card.
    - When 32 MB cards are used as a pair in memory slots 2 and 3 they can use three memory banks concurrently.
    - When used as a pair in slots 0, 1, or 2, the 32 MB cards can have two active memory banks.
    - The 16, 64, 128, and 256 MB cards each have only one memory bank that is active at any one time.

The worst case power draw is when your system has two 32MB cards in slots 2 and 3 (these banks would be considered active, all other memory cards/banks would be considered inactive). The next worst case is a 256 MB card in any slot (all other memory cards in the system would be inactive), followed by a 64 MB card in any slot (all other memory cards in the system would be inactive), followed by two 32 MB cards in slots 0, 1, or 2 (all other memory cards in the system would be inactive), followed by a 128 MB card in any slot, and finally a 16 MB card in any slot (all other memory cards in the system would be inactive).

**Power Requirements**  
**Power Distribution**

- c Inactive memory banks are those banks on cards in your configuration in addition to the worst case active memory banks. They must also be added to the calculation.
- d Fill in the information in Table 6-3 or Table 6-4.



**Figure 6-5 Model 744 Memory Slots**

**Table 6-3 Model 744/132L Memory Card Current Usage Worksheet**

Memory Card Size	First Active Bank <sup>1</sup>	Second Active Bank	Third Active Bank	Inactive Banks	Totals (+5V)
32 MB <sup>2</sup>	1.15 A	1.15 A	1.15 A	0.05A x ____	_____
64 MB	2.6 A	N/A	N/A	0.1 A x ____	_____
128 MB	1.45A	N/A	N/A	0.07 A x ____	_____
16 MB	1.15 A	N/A	N/A	0.05A x ____	_____
256 MB	2.90 A	N/A	N/A	0.14 A x ____	_____
					_____
<sup>1</sup> Choose the worst case active bank(s) for your calculation. <sup>2</sup> Slot positions and amount of 32MB cards determine the number of active banks.					

**Table 6-4 Model 744/165L Memory Card Current Usage Worksheet**

Memory Card Size	First Active Bank <sup>1</sup>	Second Active Bank	Third Active Bank	Inactive Banks	Totals (+12V)	Totals (+5V)
32 MB <sup>2</sup>	0.53 A (+12V)	0.53 A	0.53 A	0.023A x ____	_____	_____
64 MB	1.2 A (+12V)	N/A	N/A	0.05 A x ____	_____	_____
128 MB	1.45 A (+5V)	N/A	N/A	0.07 A x ____	_____	_____
16 MB	0.53 A (+12V)	N/A	N/A	0.023A x ____	_____	_____
256 MB	2.90 A (+5V)	N/A	N/A	0.14 A	_____	_____
					_____	_____
<sup>1</sup> Choose the worst case active bank(s) for your calculation. <sup>2</sup> Slot positions and amount of 32MB cards determine the number of active banks.						



- 3 Write in the board computer's current requirements in the line provided for VME slots 1 and 2 in the Lower Power Supply Worksheet (Table 6-9).
- 4 Determine each device's current requirements from the Internal Device Requirements table and the VME accessory card's specifications sheet (Table 6-7).
- 5 Write in each device's current requirements in the spaces provided in the Upper or Lower Power Supply current budgeting worksheets (Table 6-8 and Table 6-9).
- 6 Total each column in both worksheets, then write the total in the Total Current Required line.
- 7 If *either* worksheet has a column whose current totals exceed the maximum available for that column's voltage, you must reduce the number of devices to lower the total current being drawn at that voltage. You may be able to relocate VME accessory cards between the upper eight and lower two slots to reduce the power required from either power supply.

Power Requirements  
Power Distribution

**Table 6-5 Model 744 Current Requirements Worksheet**

Each Model 744 Board Computer	+5V dc Amps	+12V dc Amps	-12V dc Amps
If 132 MHz, current for +5V dc is 4.7A <sup>1</sup> If 165 MHz, current for +5V dc is 6.3A	_____	0.1A	0.1A
RAM cards (see Table 6-3 or Table 6-4)	_____	_____	
Graphics subsystems <sup>2</sup> x 0.9A each =	_____		
FWD SCSI GSC card x 0.7A each =	_____		
HCRX graphics board 2.0A	_____		
PMC bridge adapter 0.6A	_____		
PMC cards on bridge adapter <sup>3</sup>	_____	_____	_____
Totals for Model 744 board computer	_____	_____	_____
<p>1. Does not include on-board graphics, if installed.            2. On-board graphics and graphics accessory cards are each separate graphics subsystems.            3. PMC cards may also draw +3.3 current that is provided through the +5 on the bridge adapter.  <b>The +3.3 current FOR ALL PMC CARDS ON THE BRIDGE ADAPTER AND EXPANSION ADAPTER (do not include other expansion adapter currents) must be entered into the +5 column after multiplying the +3.3 current by .75 to convert to the actual +5 current draw.</b></p>			

**Table 6-6 Model 743 Current Requirements Worksheet**

Each Model 743 Board Computer	+5V dc Amps	+12V dc Amps	-12V dc Amps
If 64 MHz, current for +5V dc is 6.1A <sup>1</sup> If 100 MHz, current for +5V dc is 7.5A	_____	0.1A	0.1A
_____ RAM cards x 0.2A each =	_____		
Graphics subsystems <sup>2</sup> x 0.7A each =	_____		
FWD SCSI GSC card x 0.7A each =	_____		
HCRX graphics board 2.0A	_____		
PMC bridge adapter 0.6A	_____		
PMC cards on bridge adapter <sup>3</sup>	_____	_____	_____
Totals for Model 743 board computer	_____	_____	_____
<p>1. Does not include on-board graphics, if installed.            2. On-board graphics and graphics accessory cards are each separate graphics subsystems.            3. PMC cards may also draw +3.3 current that is provided through the +5 on the bridge adapter.  <b>The +3.3 current FOR ALL PMC CARDS ON THE BRIDGE ADAPTER AND EXPANSION ADAPTER (do not include other expansion adapter currents) must be entered into the +5 column after multiplying the +3.3 current by .75 to convert to the actual +5 current draw.</b></p>			

Table 6-7 summarizes the current requirements for internal devices.

**Table 6-7 Internal Device Current Requirements**

Device	+5.1V dc Amps	+12V dc Amps	-12V dc Amps
Internal mass storage devices:			
CD-ROM drive	1.6 A	1.8 A	
DDS tape drive	1.0 A	0.8 A	
Flexible disk drive	0.8 A		
1 GB SE hard drive	1.2 A	1.8 A	
2 GB FWD hard drive	1.1A	0.9 A	
2 GB SE hard drive	1.0 A	0.9 A	
4 GB FWD hard drive	1.1 A	1.0 A	
4 GB SE hard drive	1.0 A	1.0 A	
9 GB FWD hard drive	1.2 A	0.9 A	
Hewlett-Packard EISA Cards:			
HP 25525A SCSI DIFF	3.1 A	0.05 A	
HP 25525B EISA SCSI	3.06 A	5 mA	5 mA
HP 25560A HPIB	3.1 A		
HP 25567A LAN	3.4 A	0.04 A	
HP J2156A FDDI	2.0 A	0.09 A	0.05 A
HP J2159A X.25 PSI	3.4 A	0.04 A	
HP J2165A LAN	2.1 A		
HP J2645AA VG Any LAN	0.3 A		
HP J2802B ATM			

Power Requirements  
Power Distribution

**Table 6-8 Upper Power Supply Current Budgeting Worksheet**

Location	Device	+5V dc Amps	+12V dc Amps	-12V dc Amps
VME Slot 8	_____	_____	_____	_____
VME Slot 7	_____	_____	_____	_____
VME Slot 6	_____	_____	_____	_____
VME Slot 5	_____	_____	_____	_____
VME Slot 4	_____	_____	_____	_____
VME Slot 3 or PMC cards in Expansion Adapter*	_____	_____	_____	_____
Total Current Required:		_____	_____	_____
Maximum Available:		34.0A	8.0A	1.5A
* +3.3 current must be entered into Table 6-5 or Table 6-6				

**CAUTION:**

If you upgrade your Model 748 Ruggedized Workstation, adding more: RAM cards, mass storage devices, GSC, VME, EISA, PCI, or PMC accessory cards, you must recompute the power budget to ensure the new configuration will be within the available current each power supply can provide.

**NOTE:**

The PCI tray provides power for option cards from both a +3.3 Vdc source and a +5 Vdc source. Cards may use either or both power sources, up to 25W per slot. However, the +3.3 V dc source is limited to 39.8 W combined for slots 1 and 2, and 39.8 W combined for slots 3 and 4. For example, if the card in slot 1 draws 25 W at +3.3 V dc, only 14.8 W at +3.3 V dc is available to a card in slot 2. The limits of + 5 Vdc is 25 W per slot.

**Table 6-9 Lower Power Supply Current Budgeting Worksheet**

Location	Device	+5V dc Amps	+12V dc Amps	-12V dc Amps	-5.2V dc Amps
Mass Storage Device 1	_____	_____	_____		
Mass Storage Device 2	_____	_____	_____		
Mass Storage Device 3	_____	_____	_____		
Mass Storage Device 4	_____	_____	_____		
VME Slot 2 and VME Slot 1	Model 743/744 Board Computer	_____	_____	_____	
EISA/PCI Slot 1	_____	_____	_____	_____	_____
EISA/PCI Slot 2	_____	_____	_____	_____	_____
EISA/PCI Slot 3	_____	_____	_____	_____	_____
EISA/PCI Slot 4	_____	_____	_____	_____	_____
Total Current Required:		_____	_____	_____	_____
Maximum Available:		33.0A	8.0A	1.5A	1.0A

Power Requirements  
**Power Distribution**

---

## **Product Design Considerations**

The Product Design Considerations Chapter contains information on applications and system integration.

## Application Information

This section contains information on VME Services updates and VME system design considerations.

### VME Services Updates

At HP-UX release 10.10 and later, VME Services ships as part of the standard operating system.

For HP-UX release 9.05 and 9.07, updates to HP-UX Version 9.05 VME Services are available from Hewlett-Packard.

Updates include the following:

- Enhanced driver functionality essential for trouble-free VME applications
- Improved error messages
- On-line man pages
- Support for Model 743 VMEbus Board Computers and Model 748 Ruggedized Workstations

Also available is information that you might need to help you design and configure your VME system to work properly with the Models 743 and 748. A brief description of these VME system design considerations follows. More detailed information and information that becomes available after the printing of this manual is available on request. Please review this information before configuring your VME system or if you are having trouble getting your VME configuration to work properly.

Details on how to get VME Services Updates and Design Consideration information are available through the World Wide Web.

**[http://www.hp.com/go/hp\\_vme](http://www.hp.com/go/hp_vme)**

### VME Systems Design Considerations for Models 743, 744, and 748

This section provides a brief overview of some design considerations when configuring VME system with Models 743, 744, or 748. This overview will help you determine whether these considerations are relevant to your VME system. More detailed information is available on request.

#### Data Transfer Considerations

The sections that follow discuss data transfers within the VME system.

**VME Data Lines During Write Cycle** The VME data lines need to remain stable during the entire write cycle from a non-Model 743/744 VME bus master to the main memory of a Model 743/744 serving as a VME slave. This period includes the time from the assertion of the data strobe by the master to the receipt of the DTACK from the Model 743/744. All data lines need to remain stable in all transactions, including the higher order data lines unused in a D08 or D16 data transaction.



### **Bus Arbitration Considerations**

The sections that follow discuss VME cycle time restrictions, FAIR arbitration restrictions, and bus grant daisy chain.

**Bus Grant Daisy Chain** Each of the VME's internal VME bus masters, processor to VME data transfer controller, DMA controller, and the interrupt controller, function as separate devices in the bus grant daisy chain. As a result, each request from an individual VME bus master of the Model 743/744 results in a unique assertion of BBSY and a unique VME bus request/grant on the bus arbitration daisy chain.

### **System Integration**

The System Integration section provides information for system integrators who are incorporating the HP 9000 Series Model 742*i* into the HP 9000 Series Model 748*i* VME systems and the HP 9000 Series Model 743*i* or 744 into the HP 9000 Series Model 747*i* VME systems running HP-UX into VME systems. Topics include hardware power-on information and VME ASIC VME sysreset behavior.

### **Hardware Power On Information**

The section that follows contains information about the Models 742*i* and 747*i* and the Models 743*i*, 744, and 748*i* at the time of power on.

#### **VME ASIC Slave Behavior at Power On**

The VME ASIC on the Model 742*i* responds to VME cycles immediately upon power on. That is, VME cycles to A32 space in the address range 0x00000000 to 0x0ffffff are acknowledged by the VME ASIC, running cycles into the onboard processor RAM. This range of addresses is the default (power-on) location of the ASIC's A32 direct map window. The A32 VME address range of 0x00000000 to 0x00100000 is also acknowledged by the ASIC's A32 slave mapper, running cycles into onboard processor RAM (PA) physical addresses of 0x0 to 0xffff). This power-on behavior cannot be disabled.

VME cycles to A24 space in the VME address range of 0x0000000 to 0xffff are acknowledged by the VME ASIC, running cycles into onboard (PA) processor RAM. This range of addresses is the default (power-on) location of the VME ASIC's A24 direct map window and of the A24 slave map window. This power-on behavior cannot be disabled.

VME cycles to A16, A24, and A32 space of the VME address range of 0x0000 to 0xffff are acknowledged by the VME ASIC. This range of addresses is the default (power on) location of the VME ASIC's location monitor and FIFO register. This power on behavior cannot be disabled.

When the HP-UX operating system is loaded, the VME A32 and A24 space mapped to onboard processor RAM may be moved to another 256 MB boundary location in VME space, based on the information that the EEPROM contains (the value of the EEPROM is set through the vme\_config program). The FIFO and location monitor may also be moved; however, the current HP-RT and HP-UX services do not use the FIFO and location monitor capabilities.

The HP-RT operating system sets up the VME space for a conflict-free configuration based on information provided during the system build process. However, if there is no local memory defined on an HP-RT processor, the Model 742's default is still in place. This can lead to a conflict if another memory area is assigned that overlaps the Model 742's defaults.

## Product Design Considerations

### Application Information

In a combined Models 742i and 747i and Models 743i and 748i backplane containing one or more Models 742i and 747i VME ASICS, the address areas previously discussed must be unpopulated to avoid conflicts prior to loading the operating system. The lowest 256 MB region should be left unused for system use. For more information on combined systems, refer to `/etc/vme/example2.CFG` and the HP-RT System Administrator Task Manual.

The VME ASIC in the Models 743i and 744 does not respond to VME cycles until it is explicitly enabled by the HP-UX operating system.

#### VME ASIC VME Sysreset Behavior

When the VME ASIC is a slot 1 controller (always on the Model 747i and switch selectable on the Model 742i/rt), it generates VME sysreset and VME sysfail at power on, but ignores the state of these lines thereafter. If the VME ASIC is not a slot 1 controller, assertion of VME sysreset by another VME card causes the Model 742i/rt to reboot.

The VME ASIC in the Models 743i and 744 behaves similarly but can be configured as to whether or not a VME sysreset causes a non slot 1 controller to reboot.

#### Models 742i and 747i VME IACK Anomaly at Power On

Models 742i and 747i respond to the first interrupt cycle on any irq level after power-on with an invalid status-id by the VME ASIC. This behavior occurs regardless of whether or not Models 742i or 747i are enabled as an interrupt handler for the associated interrupt level. The patched HP-UX Version 9.05 fixes this behavior; however, the behavior should not cause problems because VME handles multiple interrupts on an irq level.

Models 743i and 744 do not exhibit this behavior.

#### VME System Configuration Information

The HP-UX `vme_config` program helps system integrators generate a conflict-free system configuration. After running `vme_config`, which writes data into the EEPROM, the system must be rebooted to use the new EEPROM information. For more information, refer to "Required Entity Declarations for HP Processors" in `/etc/vme/example(x).CFG` and the HP-UX 10.0 VME Device Drivers Manual.

#### Runtime VME ASIC Anomalies

The VME data lines need to remain stable during the entire write cycle from a non-743/744 VME bus master to the main memory of Models 743i or 744 serving as a VME slave. The write cycle includes the time from the assertion of the data strobe by the master to the receipt of DTACK from Model 743/744. All data lines need to remain stable in all transactions, including higher order data lines unused in a D08 or D16 data transaction.

---

#### **NOTE:**

If the VMEbus card bus master either drives the data lines to a known and stable state or allows the data lines to float to VME's stable high termination, there will be no parity errors. However, if the VMEbus card master drives the lines for part of the cycle and allows them to float for the remainder of the cycle, parity errors are possible on the internal Model 743/744's bus, resulting in an HP-UX panic and system crash. In HP-UX, this parity error results in a non-zero value of the bus check displayed as part of HP-UX panic. The HP-RT error message indicates that the

High Priority Machine Check (HPMC) was of type bus error with the "check Type" field equal to "20000000", the "sysReqAdd" field equal to "00109180", and the "cache", "tlb", "bus", "assists", "asstState", "sysRsAdd" fields set to zero.

---

In rare circumstances, Models 742i and 747i allow non-specified data lines to float, resulting in HP-UX panic. Most often, this behavior occurs when Models 743i and 744 are generating IACK as a D08 or D16 interrupter. To avoid this behavior, do not have Models 743i and 744 as interrupt handlers for Models 742i and 747i or configure (in the kernel interface driver that is generating the interrupt) Models 742i and 747i as D32 interrupters.

Models 742i and 747i have an internal (SGC) bus watchdog timer set to 1 ms by the boot ROM (PDC) code. When the PA processor starts a read or write transaction to VME I/O space, the watchdog timer starts. If the total time from acquiring the VME bus (arbitration time) to cycle completion time (DTACK or BERR) exceeds 1 ms, the system crashes with a HPMC. In HP-UX, the resulting panic dump message indicates a SGC bus error HPMC (this behavior cannot be changed). In either HP-UX or HP-RT, the operating system cannot recover from an HPMC error.

The system must be configured so that Models 742 or 747 always get the VME bus and complete the first transaction in less than 1 ms. This is done through vme\_config in HP-UX, and by setting specific defines, such as bus request priority, to set bus behavior in HP-RT.

Models 743i and 744 have an internal bus protocol called "split" that overcomes the 1 ms problem in Models 742i and 747i, but the processor appears hung until the VME cycle completes.

Current releases of HP-UX and HP-RT do not support the use of the location monitor capability. However, Models 742i and 747i and Models 743i and 744 handle monitoring VME locations differently:

Models 742i and 747i ASIC, if enabled, generate a local interrupt when the VME space that is defined for the location monitor is accessed. It also DTACKS the VME cycle.

Models 743i and 744 ASIC, if enabled, generate a local interrupt when the space that is defined for the location monitor is accessed. It does not+ DTACK the VME cycle.



---

# Index

---

## A

- AFR projections 3-12
- air flow requirements 4-4
- annualized failure rate 3-12
- application information 7-2-7-3
- arbitration
  - FAIR 7-3
- audio 1-20
- AUI LAN 1-21

## B

- battery specifications 5-37
- boot ROM circuit 1-16
- bus arbitration 7-3

## C

- cables
  - conversion 1-9, 4-28
  - Canadian Standards Association 3-2
- chassis
  - modules 4-29
  - parts 4-29
- clock, battery backed real-time 1-22
- clocks 1-3, 1-4, 1-5
- CODEC 1-20
- component weights 4-27
- Configuration 1-3
- controller
  - VME ASIC 1-23
- conversion audio cable 5-9
- conversion cables 1-9, 4-28
- conversion HP parallel cable 5-11
- conversion LAN cable 5-15
- conversion RS-232 cable 5-13
- conversion video cable 5-4, 5-5, 5-6, 5-7
- CPU 1-3, 1-4, 1-5
- CPU circuit 1-15

## D

- data lines 7-2
- data transfers 7-2
- dimensions
  - GSC+ accessory card 4-17
  - Model 743 RAM card 4-9
  - Model 743 system board 4-7
  - Model 744 RAM card 4-15
  - Model 744 system board 4-10
  - Model 748 center wall. 4-21
  - Model 748 chassis 4-20
  - Model 748 EISA converter board 4-25
  - Model 748 mass storage module chassis 4-22
  - Model 748 outside wall. 4-21
  - Model 748 PCI converter board 4-25
  - Model 748 PCI/EISA module chassis. 4-24
  - Model 748 power distribution board 4-26
  - Model 748 VME backplane board 4-26
  - Model 748 VME module chassis 4-23
  - PMC bridge adapter 4-18
  - PMC expansion adapter 4-19

## E

- EEPROM 7-3, 7-4
- EISA module 1-28
- electromagnetic compatibility program 3-3
- European Community 3-3

## F

- fast, wide SCSI 1-25

## FCC 3-3

- Features 1-3
- features, standard 1-3, 1-5, 1-6
- FIFO 7-3
- functionality
  - Model 743 1-11
- FW SCSI 1-25
- FW SCSI interface specifications 1-25
- FW SCSI power consumption 6-1

## G

- graphics 1-3, 1-4, 1-6
- graphics circuit 1-16
- graphics performance 1-16
- GSC
  - power distribution 6-4
- GSC mezzanine slot 1-28

## H

- HP parallel port 1-22

## I

- I/O controller 1-18
- I/O controller ASIC 1-18
- I/O performance 1-19
- input specifications 5-37
- interface
  - SCSI 1-28
- interface connector 4-6
- interval timers 1-24

## K

- key components
  - Model 743 4-2
  - Model 744 4-3

## L

- LED displays 1-18
- location monitor 7-3

## M

- main memory 1-3, 1-4, 1-6
- manuals
  - hardware 2-1
  - software 2-4
- mass storage 1-28
- mean time between failure 3-12
- mechanical drawings 4-28
- memory
  - Model 743 1-7
  - Model 744 1-7
- memory controller circuit 1-17
- Model 744 1-5, 1-6
- monitor
  - ac power specifications 6-1, 6-6
  - monitors 1-3, 1-4, 1-6
  - environmental specifications 1-31
  - supported 1-28
- MTBF computations 3-12

## O

- OEM support 1-32
- operating system 1-3, 1-4, 1-5

## P

- PCI module 1-29
- pinouts
  - audio connector 5-8

## AUI LAN 5-14

- FW SCSI connector 5-18
- HP parallel connector 5-10
- PS/2 5-20
- RS-232 5-12
- single-ended SCSI connector 5-16
- video connector 5-3
- VME connector 5-21
- PMC
  - power distribution 6-5
- PMC bridge adapter 4-18
- PMC connectors 5-26, 5-27, 5-28, 5-29, 5-30, 5-31, 5-32, 5-33, 5-34, 5-35
- PMC expansion adapter 4-19
- power 6-2
- power budgeting 6-1, 6-7
- power budgeting worksheets 6-7
- power distribution 6-1
  - GSC 6-4
  - Model 743 6-2
  - Model 744 6-3
  - PMC 6-5
- product description
  - Model 743 1-2
  - Model 744 1-2
  - Model 748 1-27
- programs
  - electromagnetic compatibility 3-3
  - safety compliance 3-2
- PS/2 ports 1-22

## Q

- quality 3-1

## R

- RAM cards 1-18
- real-time clock battery 5-37
- RS-232 serial interface 1-22
- RTC battery specifications 5-37

## S

- safety compliance programs 3-2
- SCSI 1-28
- SCSI interface 1-28
- SE SCSI 1-21
- single-ended SCSI 1-21
- single-ended SCSI connector pins 5-17
- slot configuration 1-3
- specifications
  - video 5-37
- standard support 1-32
- statistical reliability 3-12
- support
  - OEM 1-32
  - standard 1-32
- supported configurations 1-7
  - Model 748 1-27
- sysfail 7-4
- sysreset 7-4
- system graphics 1-8
- system integration 7-3, 7-3-??

## T

- temperature limits
  - integrated circuit case 4-4, 4-5
- terminators 1-28
- terminators, SCSI 1-28
- tests

---

# Index

---

acoustics 3-11  
altitude 3-9  
brownout 3-7  
brownout/recovery 3-7  
climatic and environmental 3-8  
conducted immunity 3-6  
electrical fast transients 3-6  
electromagnetic field emissions 3-4  
electromagnetic field immunity/susceptibility 3-5  
electro-static discharge 3-5  
humidity 3-9  
line blackout/dropout 3-7  
line surge 3-7  
line transients immunity/susceptibility 3-6  
magnetic emissions 3-5  
magnetic field immunity 3-6  
power level 3-11  
radiated emissions 3-4  
radiated field immunity 3-5  
sag 3-6  
shock 3-10  
surge transients 3-6  
temperature 3-9  
vibration 3-10  
TUC Rheinland 3-2

## U

Underwriter's Laboratories 3-2  
upgrades, three slots 1-4, 1-5, 1-6  
upgrades, two slots 1-3, 1-5, 1-6  
user interface 1-3, 1-4, 1-5

## V

VCCI statement 3-3  
video timing 5-37  
VME ASIC 7-3, 7-4  
VME module 1-29  
VME services updates 7-2  
VME system design considerations 7-2  
vme\_config 7-4  
Voluntary Control Council for Interference 3-3

## W

watchdog timer 1-24