

7009 Compact Server

Service Guide

7009 Compact Server

Service Guide

Second Edition (July 1995)

This edition notice applies to the *7009 Compact Server Service Guide*. This edition obsoletes all previous editions.

The following paragraph does not apply to the United Kingdom or any country where such provisions are inconsistent with local law: THIS PUBLICATION IS PRINTED "AS IS" WITHOUT WARRANTY OF ANY KIND, EITHER EXPRESS OR IMPLIED, INCLUDING, BUT NOT LIMITED TO, THE IMPLIED WARRANTIES OF MERCHANTABILITY OR FITNESS FOR A PARTICULAR PURPOSE. Some states do not allow disclaimer of express or implied warranties in certain transactions; therefore, this statement may not apply to you.

This publication could include technical inaccuracies or typographical errors. Changes are periodically made to the information herein; these changes will be incorporated in new editions of the publication.

It is possible that this publication may contain reference to, or information about, products (machines and programs), programming, or services that are not announced in your country. Such references or information must not be construed to mean that such products, programming, or services intend to be announced in your country. Any reference to a licensed program in this publication is not intended to state or imply that you can use only the licensed program mentioned. You can use any functionally equivalent program instead.

Medeco is a trademark of the Medeco Company.

PowerPC™, PowerPC 601™, and PowerPC 604™ are trademarks of International Business Machines Corporation.

©Copyright International Business Machines Corporation, 1994, 1995. All rights reserved.

Note to U.S. Government Users – Documentation and programs related to restricted rights – Use, duplication, or disclosure is subject to the restrictions set forth in the GSA ADP Schedule Contract.

Table of Contents

Communications Statements	v
Safety Notices	ix
About This Book	xi
Chapter 1. Reference Information	1-1
System Unit Locations	1-1
Front View with Cover	1-1
Front View with Door Open	1-1
Rear View	1-2
Front View without Cover	1-2
System Planar Locations	1-3
Disable/Enable the SCSI Connector	1-4
Specifications	1-5
Power Cables	1-6
Service Inspection Guide	1-7
Chapter 2. Maintenance Analysis Procedures (MAPs)	2-1520-1
MAP 1520: Power Map	2-1520-1
MAP 1540: Minimum Machine Configuration	2-1540-1
MAP 1560: Built-In Diagnostics	2-1560-1
Chapter 3. Removals and Replacements	3-1
Handling Static-Sensitive Devices	3-1
System Unit Cover	3-3
Power Supply	3-8
Diskette Drive	3-11
Media Drive	3-13
Disk Drive	3-16
Internal SCSI Cable	3-25
Adapters	3-27
Memory	3-29
Level-2 Cache Card	3-33
CPU Card	3-34
Operator Panel	3-36
Fan	3-38
Riser Card	3-41
System Planar	3-43
Battery	3-48

Chapter 4. Diagnostics	4-1
Chapter 5. Parts Information	5-1
Chassis, Power Supply, and Internal Devices	5-2
System Planar, CPU Card, and Internal Cables	5-4
Keyboard, Mouse, and Serial Dual-Port Cable	5-6
Power Cables and Plugs	5-8
Index	X-1

Communications Statements

The following statement applies to this product. The statement for other products intended for use with this product appears in their accompanying manuals.

Federal Communications Commission (FCC) Statement

Note: This equipment has been tested and found to comply with the limits for a Class A digital device, pursuant to Part 15 of the FCC Rules. These limits are designed to provide reasonable protection against harmful interference when the equipment is operated in a commercial environment. This equipment generates, uses, and can radiate radio frequency energy and, if not installed and used in accordance with the instruction manual, may cause harmful interference to radio communications. Operation of this equipment in a residential area is likely to cause harmful interference in which case the user will be required to correct the interference at his own expense.

Properly shielded and grounded cables and connectors must be used in order to meet FCC emission limits. Neither the provider nor the manufacturer are responsible for any radio or television interference caused by using other than recommended cables and connectors or by unauthorized changes or modifications to this equipment. Unauthorized changes or modifications could void the user's authority to operate the equipment.

This device complies with Part 15 of the FCC Rules. Operation is subject to the following two conditions: (1) this device may not cause harmful interference, and (2) this device must accept any interference received, including interference that may cause undesired operation.

United Kingdom Telecommunications Safety Requirements

This equipment is manufactured to the International Safety Standard EN60950 and as such is approved in the UK under the General Approval Number NS/G/1234/J/100003 for indirect connection to the public telecommunication network.

The network adapter interfaces housed within this equipment are approved separately, each one having its own independent approval number. These interface adapters, supplied by the manufacturer, do not use or contain excessive voltages. An excessive voltage is one which exceeds 70.7 V peak ac or 120 V dc. They interface with this equipment using Safe Extra Low Voltages only. In order to maintain the separate (independent) approval of the manufacturer's adapters, it is essential that other optional cards, not supplied by the manufacturer, do not use main voltages or any other excessive voltages. Seek advice from a competent engineer before installing other adapters not supplied by the manufacturer.

EC Council Directive

This product is in conformity with the protection requirements of EC Council Directive 89/336/EEC on the approximation of the laws of the Member States relating to electromagnetic compatibility.

Neither the provider nor the manufacturer can accept responsibility for any failure to satisfy the protection requirements resulting from a non-recommended modification of the product, including the fitting of option cards not supplied by the manufacturer.

International Electrotechnical Commission (IEC) Statement

This product has been designed and built to comply with IEC Standard 950.

Avis de conformité aux normes du ministère des Communications du Canada

Cet appareil numérique de la classe A respecte toutes les exigences du Règlement sur le matériel brouilleur du Canada.

Canadian Department of Communications Compliance Statement

This Class A digital apparatus meets the requirements of the Canadian Interference-Causing Equipment Regulations.

電波障害自主規制 届出装置の記述

この装置は、第一種情報装置（商工業地域において使用されるべき情報装置）で商工業地域での電波障害防止を目的とした情報処理装置等電波障害自主規制協議会（VCCI）基準に適合しております。

従って、住宅地域またはその隣接した地域で使用すると、ラジオ、テレビジョン受信機等に受信障害を与えることがあります。

取扱説明書に従って正しい取り扱いをしてください。

VCCI Statement

The following is a summary of the VCCI Japanese statement in the box above.

This equipment is in the Class 1 category (information equipment to be used in commercial and/or industrial areas) and conforms to the standards set by the Voluntary Control Council For Interference by Data Processing Equipment and Electronic Office Machines aimed at preventing radio interference in commercial and/or industrial areas.

Consequently, when used in a residential area or in an adjacent area thereto, radio interference may be caused to radios and TV receivers, etc.

Read the instructions for correct handling. VCCI-1.

Radio Protection for Germany

Dieses Gerät ist berechtigt in Übereinstimmung mit dem deutschen EMVG vom 9.Nov.92 das EG-Konformitätszeichen zu führen.

Der Aussteller der Konformitätserklärung ist die IBM Germany.

Dieses Gerät erfüllt die Bedingungen der EN 55022 Klasse A. Für diese Klasse von Geräten gilt folgende Bestimmung nach dem EMVG:

Geräte dürfen an Orten, für die sie nicht ausreichend entstört sind, nur mit besonderer Genehmigung des Bundesministers für Post und Telekommunikation oder des Bundesamtes für Post und Telekommunikation betrieben werden. Die Genehmigung wird erteilt, wenn keine elektromagnetischen Störungen zu erwarten sind.

(Auszug aus dem EMVG vom 9.Nov.92, Para.3, Abs.4)

Hinweis:

Dieses Genehmigungsverfahren ist von der Deutschen Bundespost noch nicht veröffentlicht worden.

Safety Notices

Note: For a translation of the safety notices, refer to the *System Unit Safety Information*, Order Number SA23-2652.

A *danger* notice indicates the presence of a hazard that has the potential of causing death or serious personal injury. *Danger* notices appear under the following topics on the following pages:

ix
2-1520-1
3-2
3-8.

A *caution* notice indicates the presence of a hazard that has the potential of causing moderate or minor personal injury. *Caution* notices appear under the following topics on the following pages:

ix
2-1520-1
3-2
3-48.

Electrical Safety

Observe the following safety instructions any time you are connecting or disconnecting devices attached to the workstation.

DANGER

An electrical outlet that is not correctly wired could place hazardous voltage on metal parts of the system or the devices that attach to the system. It is the responsibility of the customer to ensure that the outlet is correctly wired and grounded to prevent an electrical shock.

Before installing or removing signal cables, ensure that the power cables for the system unit and all attached devices are unplugged.

When adding or removing any additional devices to or from the system, ensure that the power cables for those devices are unplugged before the signal cables are connected. If possible, disconnect all power cables from the existing system before you add a device.

Use one hand, when possible, to connect or disconnect signal cables to prevent a possible shock from touching two surfaces with different electrical potentials.

During an electrical storm, do not connect cables for display stations, printers, telephones, or station protectors for communications lines.

DANGER

To prevent electrical shock hazard, disconnect the power cable from the electrical outlet before relocating the system.

CAUTION:

This product is equipped with a three-wire power cable and plug for the user's safety. Use this power cable in conjunction with a properly grounded electrical outlet to avoid electrical shock.

About This Book

This book provides maintenance information specific to the 7009 system unit and adapters that do not have their own service information. It also contains Maintenance Analysis Procedures (MAPs) that are not common to other systems.

MAPs that are common to all systems are contained in the *POWERstation and POWERserver Common Diagnostics Information Manual*.

This book is used by the service technician to repair system failures. This book assumes that the service technician has had training on the 7009 system unit.

Related Information

The *POWERstation and POWERserver Common Diagnostics Information Manual*, Order Number SA23-2665, Section I, contains the maintenance information and procedures that are common to all systems. The information and procedures in this book apply to any system unit that uses the diagnostic programs.

The *Adapters, Devices, and Cable Information*, Order Number SA23-2764, contains reference information about adapters, devices, and cabling for the system units. This manual also contains the removal and replacement procedures for the logic boards on the disk drives. This manual provides the service representative pin-out lists and cabling information to use in isolating problems with customer cabling.

The *7009 Compact Server Operator Guide*, Order Number SA23-2715, provides information about the controls and features of the system unit.

The *7009 Compact Server Hardware Setup Procedure*, Order Number SA23-2717, is a pictorial guide designed to help you quickly set up your 7009 system unit.

Chapter 1. Reference Information

System Unit Locations

Front View with Cover

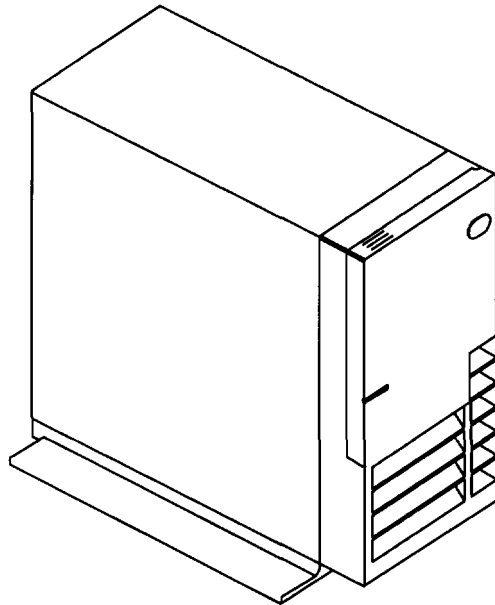

Front View with Door Open

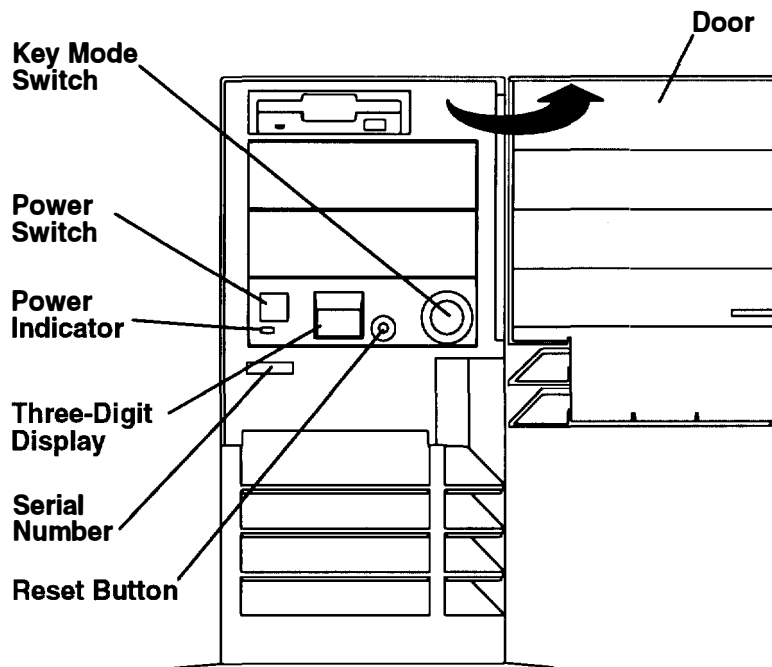

Rear View

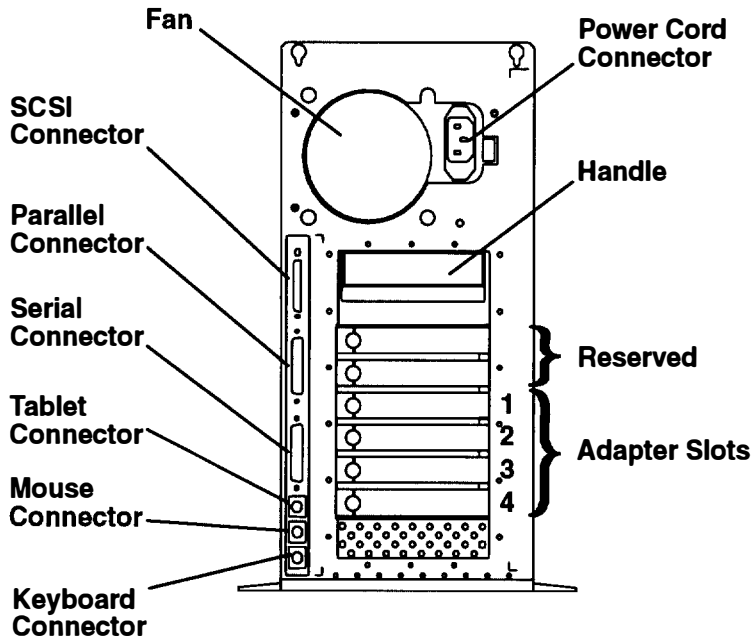

Front View without Cover

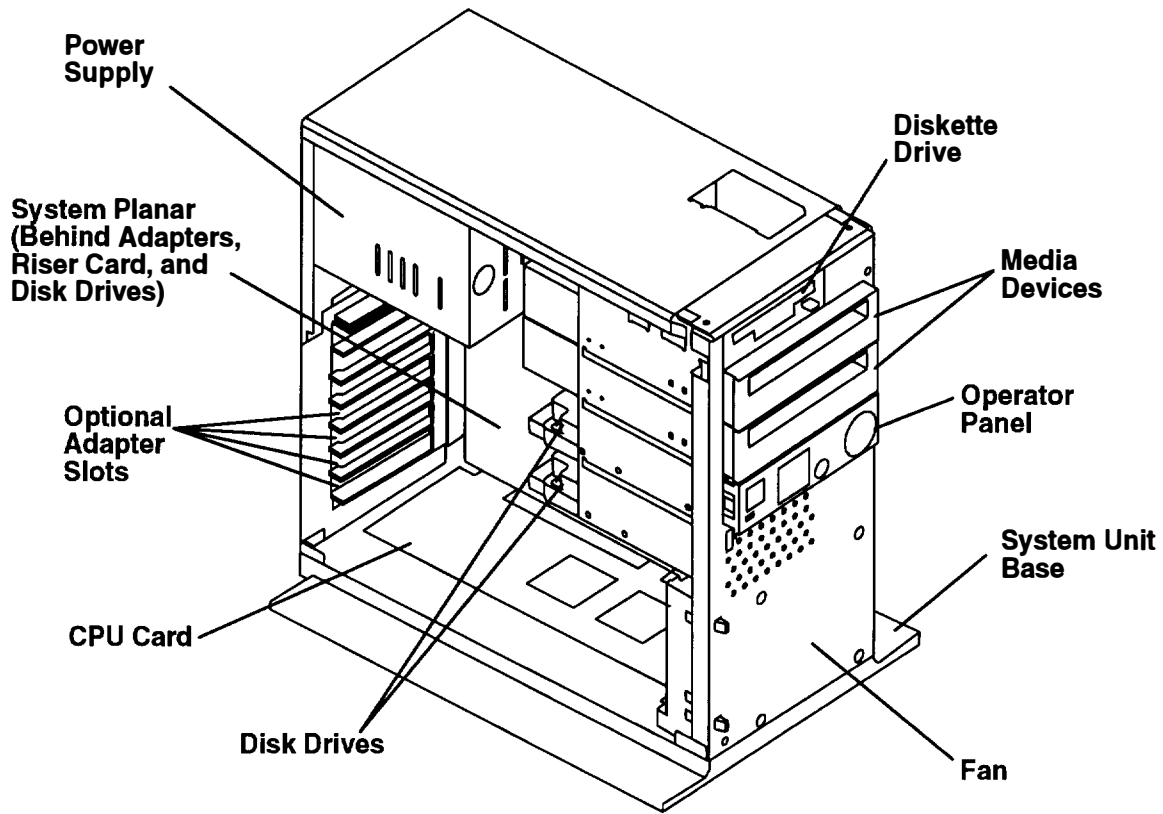

System Planar Locations

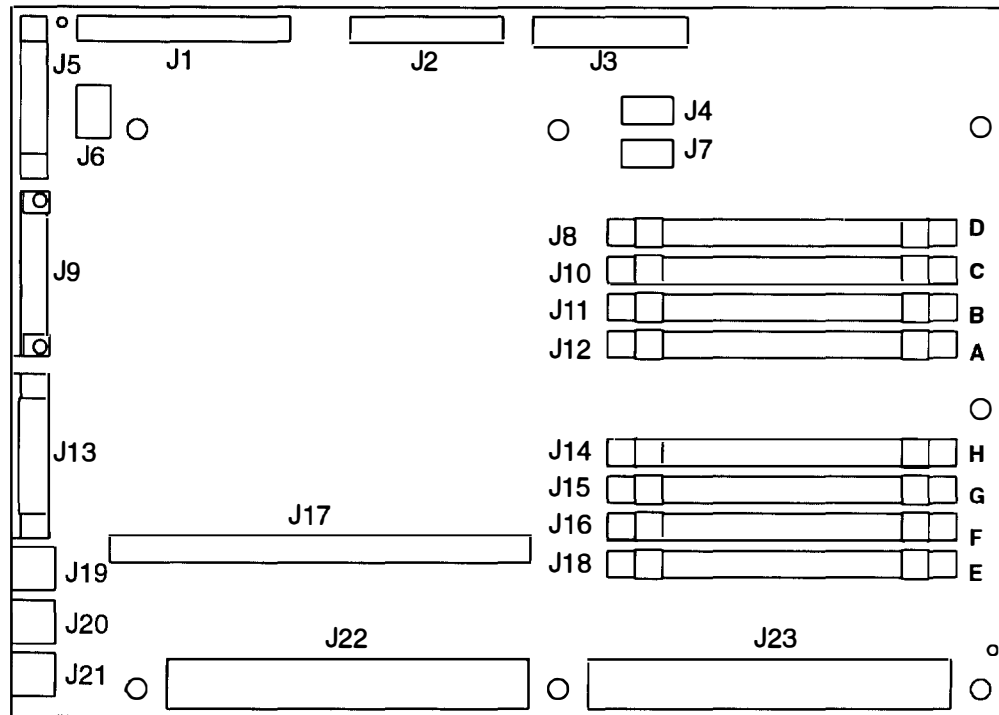

Connector	Function
J1	Internal SCSI Device Cable
J2	Diskette Connector
J3	Power Supply Connector
J4	Keylock Connector
J5	SCSI Connector
J6	SCSI Enable/Disable Jumpers
J7	Three-Digit Display Connector
J9	Parallel Connector
J8, J10, J11, J12	Set 0 of Memory (SIMMs) Connectors
J14, J15, J16, J18	Set 1 of Memory (SIMMs) Connectors
J13	Serial Connector
J17	Riser Card Connector
J19	Tablet Connector
J20	Mouse Connector
J21	Keyboard Connector
J22, J23	CPU Card Connector

Disable/Enable the SCSI Connector

Optional data security for the internal SCSI devices is provided by five jumpers (J6) on the system planar. These jumpers (when set to the disabled position) prevent communication through the external SCSI connector. The default setting of the jumpers from the manufacturer is SCSI connector *enabled*. To change the SCSI jumper setting:

1. If you have not already done so, remove the cover as described in "System Unit Cover" on page 3-3.
2. Gently lay the system unit down so that the open side faces upward.

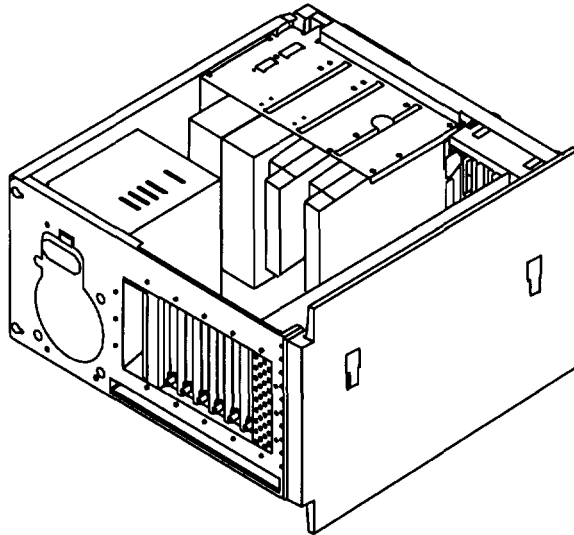

3. Locate the SCSI enable/disable jumpers on the system planar. Remove the jumpers and replace them all in the disabled or enabled position.

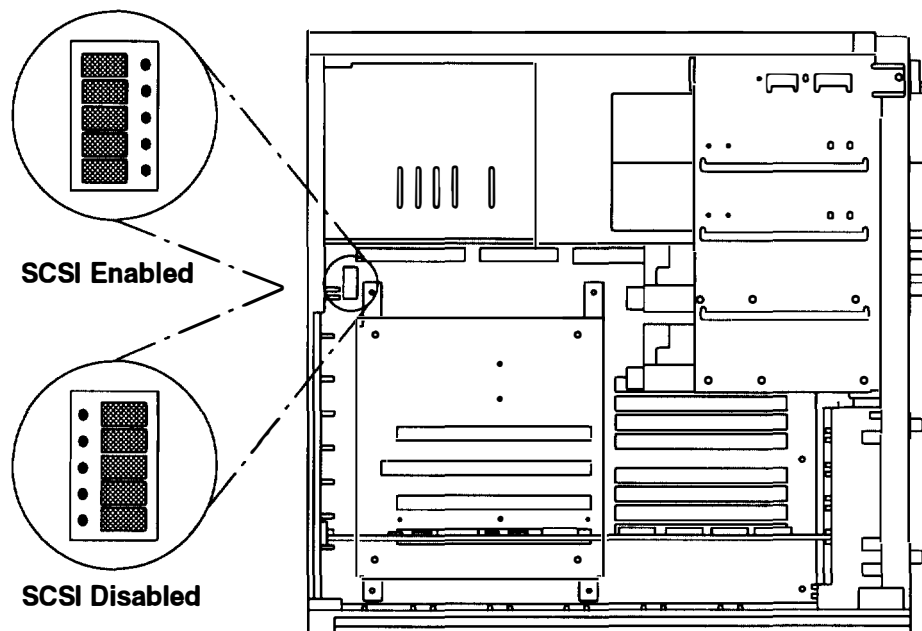

4. Do the replacement procedure in "System Unit Cover" on page 3-3.

Specifications

The mechanical packaging, cooling, power supply, and environmental requirements for the Compact Server are shown in the following:

Dimensions

Height: 394 mm (15.5 inches)

Depth: 432 mm (17 inches)

Width: 240 mm (9.5 inches), with pedestal

Weight

Minimum: 16 kg (35 pounds)

Maximum: 18 kg (39.5 pounds)

Operating Environment – Class B

Temperature: 16° to 32° C (60° to 90° F)

Humidity: 8% to 80 % noncondensing

Maximum Altitude: 2135 m (7000 feet)

Power Source Loading

Model C10: 0.232k VA maximum

Model C20: 0.250 k VA maximum

Power Supply

272 watts

Operating Voltage (Autoranging)

100 to 125 V ac; 50 to 60 Hz

200 to 240 V ac; 50 to 60 Hz

Heat Output (Maximum)

Model C10: 512 BTU per hour

Model C20: 544 BTU per hour

Acoustics

5.7 Bels operating

5.3 Bels idle

Power Cables

To avoid electrical shock, a power cable with a grounded attachment plug is provided. Use only properly grounded outlets.

Power cables used in the United States and Canada are listed by Underwriter's Laboratories (UL) and certified by the Canadian Standards Association (CSA). These power cords consist of:

- Electrical cables, Type SVT or SJT.
- Attachment plugs complying with National Electrical Manufacturers Association (NEMA) 5-15P. That is:

“For 115 V operation, use a UL listed cable set consisting of a minimum 18 AWG, Type SVT or SJT three-conductor cord a maximum of 15 feet in length and a parallel blade, grounding type attachment plug rated at 15 A, 125 V.”

“For 230 V operation in the United States use a UL listed cable set consisting of a minimum 18 AWG, Type SVT or SJT three-conductor cable a maximum of 15 feet in length, and a tandem blade, grounding type attachment plug rated at 15 A, 250 V.”

- Appliance couplers complying with International Electrotechnical Commission (IEC) Standard 320, Sheet C13.

Power cables used in other countries consist of the following:

- Electrical cables, Type HD21.
- Attachment plugs approved by the appropriate testing organization for the specific countries where they are used.

“For units set at 230 V (outside of U.S.): use a cable set consisting of a minimum 18 AWG cable and grounding type attachment plug rated 15 A, 250 V. The cable set should have the appropriate safety approvals for the country in which the equipment will be installed and should be marked 'HAR'.”

Refer to Chapter 5, “Parts Information” for information about available power cables.

Service Inspection Guide

Perform a service inspection on the system when:

- The system is inspected for a maintenance agreement.
- Service is requested and service has not recently been performed.
- An alterations and attachments review is performed.
- Changes have been made to the equipment that may affect the safe operation of the equipment.
- External devices with their own power cables have those cables attached.

If the inspection indicates an unacceptable safety condition, the condition must be corrected before anyone can service the machine.

Note: The correction of any unsafe condition is the responsibility of the owner of the system.

Perform the following checks:

1. Check the covers for sharp edges and for damage or alterations that expose the internal parts of the system unit.
2. Check the covers for proper fit to the system unit. They should be in place and secure.
3. Gently rock the system unit from side to side to determine if it is steady.
4. Set the power switch of the system unit to Off.
5. Remove the covers.
6. Check for alterations or attachments. If there are any, check for obvious safety hazards such as broken wires, sharp edges, or broken insulation.
7. Check the internal cables for damage.
8. Check for dirt, water, and any other contamination within the system unit.
9. Check the voltage label on the back of the system unit to ensure that it matches the voltage at the outlet.
10. Check the external power cable for damage.
11. With the external power cable connected to the system unit, check for 0.1 ohm or less resistance between the ground lug on the external power cable plug and the metal frame.
12. Perform the following checks on each device that has its own power cables:
 - a. Check for damage to the power cord.
 - b. Check for the correct grounded power cable.
 - c. With the external power cable connected to the device, check for 0.1 ohm or less resistance between the ground lug on the external power cable plug and the metal frame of the device.
13. Install the covers.

Chapter 2. Maintenance Analysis Procedures (MAPs)

MAP 1520: Power Map

Note: This is not the “Start of Call” MAP. For the “Start of Call” MAP, refer to the *POWERstation and POWERserver Common Diagnostics Information Manual*.

Purpose of This MAP

The Power MAP assists the trained service person in analyzing power problems in the system unit.

DANGER

An electrical outlet that is not correctly wired could place hazardous voltage on metal parts of the system or the devices that attach to the system. It is the responsibility of the customer to ensure that the outlet is correctly wired and grounded to prevent an electrical shock.

Before installing or removing signal cables, ensure that the power cables for the system unit and all attached devices are unplugged.

When adding or removing any additional devices to or from the system, ensure that the power cables for those devices are unplugged before the signal cables are connected. If possible, disconnect all power cables from the existing system before you add a device.

Use one hand, when possible, to connect or disconnect signal cables to prevent a possible shock from touching two surfaces with different electrical potentials.

During an electrical storm, do not connect cables for display stations, printers, telephones, or station protectors for communications lines.

CAUTION:

This product is equipped with a three-wire power cable and plug for the user’s safety. Use this power cable with a properly grounded electrical outlet to avoid electrical shock.

Step 1.

Verify that the power supply switch is set to match the voltage supplied by the power outlets.

Check that the external power cable to the system unit has continuity, the power cable is plugged into both the system unit and the outlet, and the outlet has the correct voltage.

Did you find a problem?

NO Go to Step 2.

YES Correct the problem and go to Step 18.

Step 2.

(from Step 1)

1. Set the power switch on the system unit to Off.
2. Remove the cover. (Refer to "System Unit Cover" on page 3-3.)
3. Verify that the power supply cable to the operator panel is connected properly to the operator panel. (Refer to "Operator Panel" on page 3-36.)
4. Verify that the front cooling fan cable is connected properly to the operator panel. (Refer to "Operator Panel" on page 3-36.)
5. Set the power switch on the system unit to On.

Did the power-on light come on and stay on, and are both the power supply fan and front cooling fan running continuously?

- NO** Go to Step 3.
YES Go to Step 18.

Step 3.

(from Step 2)

1. Set the power switch on the system unit to Off.
2. Disconnect the power supply connectors from the system planar and from any installed disk drives and media drives.
3. Disconnect the front cooling fan cable from the operator panel card.
4. Set the power switch on the system unit to On.

Did the power-on light come on and stay on, and is the power supply fan running continuously?

- NO** The power supply or operator panel must be replaced. Replace the power supply and return to Step 1 to verify operation. If the power-on light and power supply fan still are not on continuously, replace the operator panel and go to Step 18.
YES Go to Step 4.

Step 4.

(from Step 3)

1. Set the power switch on the system unit to Off.
2. Connect the front cooling fan cable to the operator panel card.
3. Set the power switch on the system unit to On.

Did the power-on light come on and stay on, and are both the power supply fan and front cooling fan running continuously?

- NO** Replace the front cooling fan and go to Step 18.
YES Go to Step 5.

Step 5.

(from Step 4)

Is a disk drive or media drive installed?

- NO** Go to Step 7.
YES Go to Step 6.

Step 6.

(from Step 5)

1. Set the power switch on the system unit to Off.
2. Connect the disk drive or media drive power cable connector.
3. Set the power switch on the system unit to On.

Did the power light come on and stay on?

- NO** Exchange the following in the indicated order, then go to Step 18.
1. Disk drive or media drive
 2. Signal cable.
- YES** Repeat Step 6 until all disk drives and media drives have been reconnected. Go to Step 7.

Step 7.

(from Steps 5 and 6)

1. Set the power switch on the system unit to Off.
2. Connect the power supply connector to the system planar.

Is a diskette drive installed?

- NO** Go to Step 9.
YES Go to Step 8.

Step 8.

(from Step 7)

1. Disconnect the diskette drive signal cable connector from the system planar.
2. Set the power switch on the system unit to On.

Did the power light come on and stay on?

- NO** Go to Step 9.
YES Exchange the diskette drive and go to Step 18.

Step 9.

(from Steps 7 and 8)

1. Set the power switch on the system unit to Off.
2. Record the location of each adapter.
3. Remove one adapter.
4. Set the power switch on the system unit to On.

Did the power light come on and stay on?

- NO** Repeat this step until all adapters have been removed, then go to Step 10.
- YES** Go to Step 11.

Step 10.

(from Step 9)

1. Set the power switch on the system unit to Off.
2. Unplug one cable from the back of the system unit, such as the keyboard, tablet, mouse, serial or parallel device.
3. Set the power switch on the system unit to On.

Did the power light come on and stay on?

- NO** Repeat this step until all cables have been removed, then go to Step 16.
- YES** Repair or exchange the cable or device that was just removed, then go to Step 18.

Step 11.

(from Step 9)

Examine the adapter that was removed.

Were any cables connected to the adapter?

- NO** Go to Step 12.
- YES** Go to Step 14.

Step 12.

(from Step 11)

Refer to the *POWERstation and POWERserver Common Diagnostics Information Manual* to see if the adapter has more than one field-replaceable unit (FRU).

Does the failing adapter have additional FRUs?

- NO** Exchange the failing adapter, then go to Step 18.
- YES** Go to Step 13.

Step 13.

(from Step 12)

1. Set the power switch on the system unit to Off.
2. Remove all FRUs from the failing adapter.
3. Replace the failing adapter on the system planar.
4. Set the power switch on the system unit to On. Wait 10 seconds, then answer the following question:

Is the power-on light on?

- NO** Exchange the failing adapter, then go to Step 18.
- YES** One of the additional FRUs that was removed is failing. If only one FRU was removed, exchange it. Otherwise, replace the removed FRUs, one at a time until you identify the failing FRU. Exchange the failing FRU and go to Step 18.

Step 14.

(from Step 11)

1. Set the power switch on the system unit to Off.
2. Replace the adapter without its cables.
3. Set the power switch on the system unit to On.

Did the power-on light come on and stay on?

- NO** Exchange the adapter, then go to Step 18.
- YES** Go to Step 15.

Step 15.

(from Step 14)

Either the cable or the device is defective.

1. Set the power switch on the system unit to Off.
2. Disconnect everything from the device end of the cable.
3. Connect the cable to the adapter.
4. Set the power switch on the system unit to On.

Did the power-on light come on and stay on?

- NO** Exchange the cable, then go to Step 18.
- YES** Repair or exchange the defective device, then go to Step 18.

Step 16.

(from Step 10)

1. Remove one SIMM.
2. Set the power switch on the system unit to On.

Did the power-on light come on and stay on?

- NO** Repeat this step until all SIMMS have been removed, then go to Step 17.
- YES** Exchange the SIMM that was last removed, then go to Step 18.

Step 17.

(from Step 16)

1. Set the power switch on the system unit to Off.
2. Disconnect one of the following: the operator panel, CPU card, or any other cable (except the power cable) attached to the system planar.
3. Set the power switch on the system unit to On.

Did the power-on light come on and stay on?

- NO** Repeat this step until the defective part is located or all connectors have been disconnected, then exchange the system planar and go to Step 18.
- YES** Repair or exchange the FRU that was removed, then go to Step 18.

Step 18.

(from Steps 1, 2, 3, 4, 6, 8, 10, 12, 13, 14, 15, 16, and 17)

Replace the cover if removed.

This completes the repair. Go to "MAP 0410: Repair Checkout" in the *POWERstation and POWERserver Common Diagnostics Information Manual*.

MAP 1540: Minimum Machine Configuration

Purpose of This MAP

The Minimum Machine Configuration Map assists the trained service representative in analyzing configuration problems in the system unit.

Step 1.

(from Steps 3, 9, 12, 14, 17, 18, and 22)

1. Set the power switch on the system unit to Off.
2. Set the key mode switch to the Service position.
3. Remove the CPU feature card, if present.
4. Record the slot numbers of the adapters and any cables attached to the adapter. Remove any adapters in slots 1, 2, 3, and 4.
5. Remove the Micro Channel riser card from the system planar.
6. Remove any memory SIMMs and record their socket numbers.
7. Unplug the internal SCSI device cable.
8. Disconnect the diskette drive cable if present.
9. Disconnect all external device cables.
10. Set the power switch on the system unit to On.
11. Wait for one of the following conditions:
 - The system stops for at least one minute with a constant number, character, or symbol in the three-digit display.
 - A flashing 888 is displayed in the three-digit display.

Is 213 displayed in the three-digit display?

NO Go to Step 2.

YES Go to Step 4.

Step 2.

(from Step 1)

Is 211 displayed in the three-digit display?

NO Go to Step 3.

YES Exchange the system planar and retry Step 1. If this does not fix the problem, continue to Step 3.

Step 3.

(from Step 2)

One of the FRUs in the system is defective.

- Exchange the FRUs that have not been exchanged in the following order:
 1. System planar
 2. CPU card
 3. CPU feature card
 4. Power supply.
- Test each FRU by turning the system power On. No failure has been detected when the system stops with 213 in the three-digit display. The last FRU exchanged is defective.

Were you able to identify the defective FRU?

- NO** Set the power switch on the system unit to Off.
 If the symptom changed, go to Step 1.
 If the symptom did not change, call your next level of support for assistance.
- YES** Go to Step 19.

Step 4.

(from Step 1)

No failure was detected. One of the FRUs you removed is probably defective.

1. Set the power switch on the system unit to Off.
2. Install a set of four matching SIMMs in positions A, B, C, and D.
 Refer to page 1-3 for an illustration of the SIMM locations on the system planar.
3. Set the power switch on the system unit to On.
4. Wait for one of the following conditions:
 - The system stops for at least one minute with a constant number, character, or symbol in the three-digit display.
 - A flashing 888 is displayed in the three-digit display.

Is 261 or 262 displayed in the three-digit display?

- NO** Go to Step 8.
- YES** Go to Step 5.

Step 5.

(from Step 4)

Are all of the memory SIMMs that were removed previously, now installed back into the system unit?

- NO** Go to Step 6.
- YES** Go to Step 13.

Step 6.

(from Step 5)

No failure was detected. One of the FRUs you removed is probably defective.

1. Set the power switch on the system unit to Off.
2. Reinstall the next quad of SIMMs (set of four) in their original slots.
3. Set the power switch on the system unit to On.
4. Wait for one of the following conditions:
 - The system stops for at least one minute with a constant number, character, or symbol in the three-digit display.
 - A flashing 888 is displayed in the three-digit display.

Is 261 or 262 displayed in the three-digit display?

NO Go to Step 7.

YES Go to Step 13.

Step 7.

(from Step 6)

One of the FRUs in the system is defective.

Exchange the FRUs that have not been exchanged in the following order:

- Memory SIMMs
 - CPU card
 - CPU feature card
 - System planar.
1. Test each FRU by setting the power switch on the system unit to On. No failure has been detected when the system stops with 261 or 262 in the three-digit display. Any other condition means the FRU is defective.
 2. Go to Step 19.

Step 8.

(from Step 4)

One of the FRUs in the system unit is defective.

Do you have another quad of SIMMS?

NO Go to Step 9.

YES Go to Step 10.

Step 9.

(from Step 8)

Exchange the FRUs that have not been exchanged in the following order:

1. Memory SIMMs
2. CPU card
3. CPU feature card
4. System planar
5. Power supply.

Test each FRU by setting the power switch on the system unit to On. No failure has been detected when the system stops with 261 or 262 in the three-digit display. The last FRU exchanged is defective.

Were you able to identify the defective FRU?

- NO** Set the power switch on the system unit to Off.
 If the symptom changed, go to Step 1.
 If the symptom did not change, call your next level of support for assistance.
- YES** Go to Step 19.

Step 10.

(from Step 8)

1. Set the power switch on the system unit to Off.
2. Remove the quad of SIMMs in positions A, B, C, and D.
 Refer to page 1-3 for an illustration of the SIMM locations on the system planar.
3. Install a different quad of SIMMs in positions A, B, C, and D.
4. Set the power switch on the system unit to On.
5. Wait for one of the following conditions:
 - The system stops for at least one minute with a constant number, character, or symbol in the three-digit display.
 - A flashing 888 is displayed in the three-digit display.

Is 261 or 262 displayed in the three-digit display?

- NO** Go to Step 12.
- YES** Go to Step 11.

Step 11.

(from Step 10)

One of the SIMMs you just removed is defective.

1. Test each FRU by setting the power switch on the system unit to On. No failure has been detected when the system stops with 261 or 262 in the three-digit display. Any other condition means the memory SIMM is defective.
2. Exchange the defective SIMM.
3. Go to Step 19.

Step 12.

(from Step 10)

Exchange the FRUs that have not been exchanged in the following order:

1. System planar
2. CPU card
3. CPU feature card
4. Power supply.

Test each FRU by setting the power switch on the system unit to On. No failure has been detected when the system stops with 261 or 262 in the three-digit display. The last FRU exchanged is defective.

Were you able to identify the defective FRU?

- NO** Set the power switch on the system unit to Off.
 If the symptom changed, go to Step 1.
 If the symptom did not change, call your next level of support for assistance.
- YES** Go to Step 19.

Step 13.

(from Steps 5 and 6)

No failures have been detected. One of the FRUs you removed is probably defective.

1. Set the power switch on the system unit to Off.
2. Connect either:
 - An ASCII terminal to serial port 1
 - A keyboard and display (requires display adapter).
3. Set the power switch on the system unit to On.
4. Wait for one of the following conditions:
 - The system stops for at least one minute with a constant number, character, or symbol in the three-digit display.
 - A flashing 888 is displayed in the three-digit display.

Is 260, 261 or 262 displayed in the three-digit display?

NO Go to Step 14.

YES Go to Step 15.

Step 14.

(from Step 13)

Exchange the FRUs that have not been exchanged in the following order:

1. Keyboard
2. System planar
3. CPU card
4. CPU feature card
5. Power supply.

Test each FRU by setting the power switch on the system unit to On. No failure has been detected when the system stops with either 260, 261, or 262 in the three-digit display. The last FRU exchanged is defective.

Were you able to identify the defective FRU?

NO Set the power switch on the system unit to Off.

 If the symptom changed, go to Step 1.

 If the symptom did not change, call your next level of support for assistance.

YES Go to Step 19.

Step 15.

(from Step 13)

The system is working correctly with this configuration. One of the FRUs you removed is probably defective.

If you are using a terminal attached to serial port 1, press any key.

Did the Main Menu display?

NO Go to Step 16.

YES Go to Step 20.

Step 16.

(from Step 15)

Was an SRN reported?

NO Go to Step 17.

YES Go to Step 18.

Step 17.

(from Step 16)

Exchange the FRUs that have not been exchanged in the following order:

1. Display, adapter, or terminal
2. System planar
3. CPU card
4. CPU feature card
5. Power supply.

Test each FRU by rerunning the diagnostics.

Were you able to identify the defective FRU?

NO Set the power switch on the system unit to Off.

If the symptom changed, go to Step 1.

If the symptom did not change, call your next level of support for assistance.

YES Go to Step 18.

Step 18.

(from Steps 16, 17, 20, 21, and 22)

Exchange the FRUs indicated by the SRN.

Test each FRU by rerunning the diagnostics.

Were you able to identify the defective FRU?

NO Set the power switch on the system unit to Off.

If the symptom changed, go to Step 1.

If the symptom did not change, call your next level of support for assistance.

YES Go to Step 19.

Step 19.

(from Steps 3, 7, 9, 11, 12, 14, and 18)

Starting with your initial program load (IPL) device, replace all other FRUs you have removed.

Run diagnostics after all the FRUs have been replaced.

When all FRUs have been tested and replaced if necessary, go to "Map 0410: Repair Checkout" in the *POWERstation and POWERserver Common Diagnostics Information Manual*.

Step 20.

(from Step 15)

Run the diagnostics.

Was an SRN reported?

NO Go to Step 21.

YES Go to Step 18.

Step 21.

(from Step 20)

Replace all remaining FRUs one at a time.

Run diagnostics each time a FRU is added.

Was an SRN reported?

NO Go to Step 22.

YES Go to Step 18.

Step 22.

(from Step 21)

Exchange the FRUs that have not been exchanged in the following order:

1. IPL device
2. System planar
3. CPU card
4. CPU feature card
5. Power supply.

Test each FRU by rerunning the diagnostics.

Were you able to identify the defective FRU?

- | | |
|------------|--|
| NO | Set the power switch on the system unit to Off.
If the symptom changed, go to Step 1.
If the symptom did not change, call your next level of support for assistance. |
| YES | Go to Step 18. |

MAP 1560: Built-In Diagnostics

Purpose of This MAP

The Diagnostics MAP assists the trained service representative in using the system unit's built-in diagnostic programs. This MAP should be used when the system diagnostics cannot be loaded because of a hardware problem. Entry into this MAP should be from "MAP 0020" in the *POWERstation and POWERserver Common Diagnostics Information Manual*.

Step 1.

1. Set the power switch on the system unit to Off.
2. Set the mode switch to the Secure position.
3. Wait 10 seconds.
4. Turn on system power.
5. Wait until one of the following occurs:
 - The same number is displayed in the three-digit display for more than one minute.
 - The number 888 flashes in the three-digit display.
 - The system stops with nothing displayed in the three-digit display.
 - The system stops with a menu displayed.

Is 200 displayed in the three-digit display?

- | | |
|------------|---------------|
| NO | Go to Step 2. |
| YES | Go to Step 3. |

Step 2.

(from Step 1)

Is the Configuration and Diagnostics Main Menu displayed?

- | | |
|------------|---|
| NO | Go to "MAP 0020: Problem Determination Procedure," Step 1, in the <i>POWERstation and POWERserver Common Diagnostics Information Manual</i> . |
| YES | Perform the following: <ol style="list-style-type: none">1. Record SRN 111-102.2. Go to Step 9. |

Step 3.

(from Step 1)

1. Set the mode switch to the Service position.
2. Press the system Reset button.
3. Wait until one of the following occurs:
 - The same number is displayed in the three-digit display for more than one minute.
 - The number 888 flashes in the three-digit display.
 - The system stops with nothing displayed in the three-digit display.
 - The system stops with a menu displayed.

Is the Configuration and Diagnostics Main Menu displayed?

- | | |
|-----|--|
| NO | Go to "MAP 0020: Problem Determination Procedure," Step 1 in the <i>POWERstation and POWERserver Common Diagnostics Information Manual</i> . |
| YES | Go to Step 4. |

Step 4.

(from Step 3)

Select option 5, Perform Diagnostics, and wait for the system unit to determine SCSI configuration.

Is the Diagnostics screen displayed?

- | | |
|-----|--|
| NO | Perform the following: <ol style="list-style-type: none">1. Record SRN 111-921.2. Go to Step 9. |
| YES | Go to Step 5. |

Step 5.

(from Step 4)

Select option 2, Perform Built-In ADVANCED Diagnostics.

Is the Test Selection menu displayed?

- | | |
|-----|------------------------|
| NO | Perform the following: |
| | 1. Record SRN 111-921. |
| | 2. Go to Step 9. |
| YES | Go to Step 6. |

Step 6.

(from Step 5)

1. Select option 1, Run All Built-In ADVANCED Diagnostics.
2. When the Test Mode screen appears, select option 1, Run One Time.
3. Follow the displayed instructions for each test.

Did you arrive at the Test Completed, No Trouble Found menu?

- | | |
|-----|----------------|
| NO | Go to Step 7. |
| YES | Go to Step 10. |

Step 7.

(from Step 6)

Did the system stop with an SRN displayed?

- | | |
|-----|---------------|
| NO | Go to Step 8. |
| YES | Go to Step 9. |

Step 8.

(from Step 7)

Did the system stop with a steady number displayed in the three-digit display?

- | | |
|-----|--|
| NO | Go to MAP 1540, Step 1. |
| YES | Perform the following: |
| | 1. Record SRN 101-xxx, where xxx is the number displayed in the three-digit display. |
| | 2. Go to Step 9. |

Step 9.

(from Steps 2, 4, 5, 7, and 8)

1. Find the SRN in the "Service Request Number List" in Chapter 2 of the *POWERstation and POWERserver Common Diagnostics Information Manual*.
2. Proceed to the MAP listed in the Description and Action column.

Step 10.

(from Step 6)

All built-in diagnostics have run without error. If you are trying to IPL over a communications network, problems could be caused by configuration errors, network errors, or host problems. Local problem determination procedures should be used before returning to operating system diagnostics.

Go to "MAP 0020: Problem Determination Procedure," Step 1 in the *POWERstation and POWERserver Common Diagnostics Information Manual*.

Chapter 3. Removals and Replacements

Before performing any of the removal or replacement procedures in this chapter, read the following notice.

Handling Static-Sensitive Devices

Warning: Adapters, system boards, diskette drives, media drives, disk drives, CPU cards, and SIMMs are sensitive to static electricity discharge. These devices are wrapped in antistatic bags, as shown in this illustration, to prevent this damage.

Take the following precautions:

- If you have an antistatic wrist strap available, use it while handling the device.
- Do not remove the device from the antistatic bag until you are ready to install the device in the system unit.
- With the device still in its antistatic bag, touch it to a metal frame of the system.
- Grasp cards and boards by the edges. Hold drives by the frame. Avoid touching the solder joints or pins.
- If you need to lay the device down while it is out of the antistatic bag, lay it on the antistatic bag. Before picking it up again, touch the antistatic bag and the metal frame of the system unit at the same time.
- Handle the devices carefully in order to prevent permanent damage.

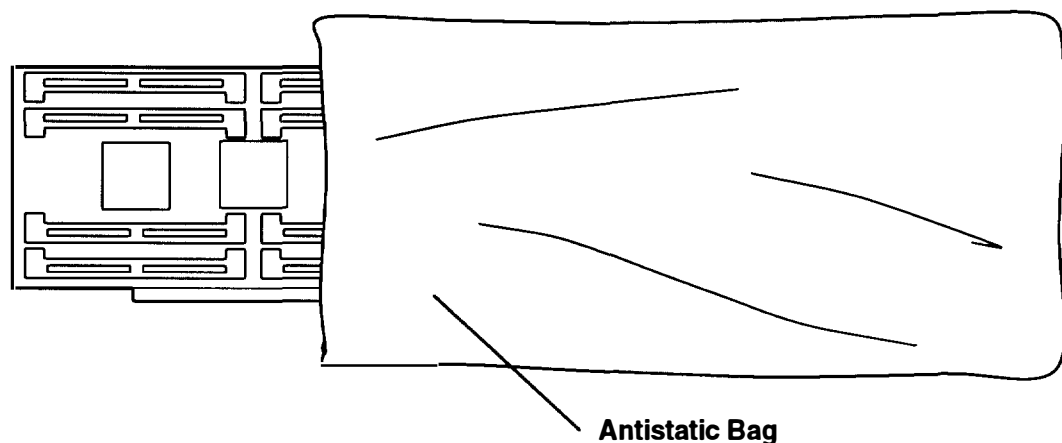

DANGER

An electrical outlet that is not correctly wired could place hazardous voltage on metal parts of the system or the devices that attach to the system. It is the responsibility of the customer to ensure that the outlet is correctly wired and grounded to prevent an electrical shock.

Before installing or removing signal cables, ensure that the power cables for the system unit and all attached devices are unplugged.

When adding or removing any additional devices to or from the system, ensure that the power cables for those devices are unplugged before the signal cables are connected. If possible, disconnect all power cables from the existing system before you add a device.

Use one hand, when possible, to connect or disconnect signal cables to prevent a possible shock from touching two surfaces with different electrical potentials.

During an electrical storm, do not connect cables for display stations, printers, telephones, or station protectors for communications lines.

CAUTION:

This product is equipped with a three-wire power cable and plug for the user's safety. Use this power cable with a properly grounded electrical outlet to avoid electrical shock.

System Unit Cover

Removal

1. Shut down the system unit:
 - a. If the operating system is still responding to commands, enter the correct **shutdown** command. Failure to do so may result in loss of data. If you need information on the shutdown procedure for your operating system, refer to your operating system documentation.
 - b. After you shut down the operating system, set the power switches of the attached devices to Off.
 - c. Turn off the system unit.
2. Set the key mode switch to the Service position.

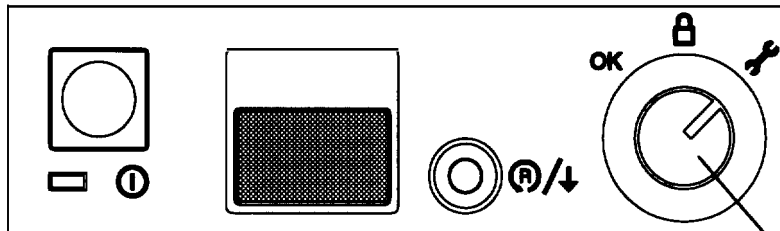

**Key Mode Switch
(Service Position)**

3. Remove the keys (if present) and set them in a safe place.
4. Close the operator door.
5. Unplug the system unit power cable and attached device power cables from electrical outlets.
6. To remove the cover, pull forward on the bottom of the front while steadying the pedestal.

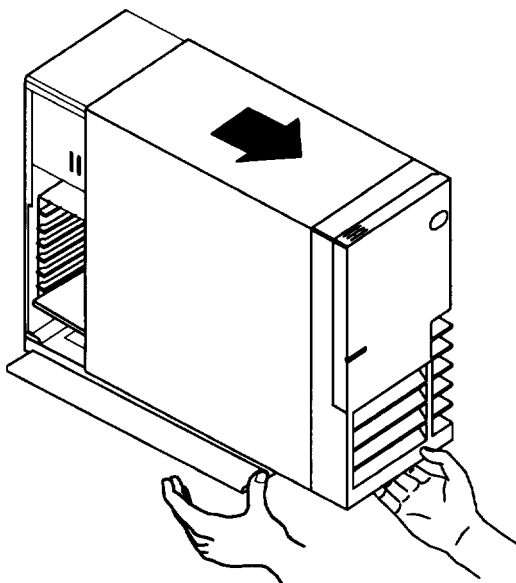

7. If you are removing the system unit cover in order to remove or replace a diskette drive, optional adapter, Level-2 Cache card, CPU card, or CPU card battery, then you have now completed the system unit cover removal procedure. It is not necessary to remove the Fast/Wide SCSI cable and airflow baffle.
8. If your system unit contains an optional Fast/Wide SCSI adapter connected to internal SCSI devices, then do the following:
 - a. Unplug the internal Fast/Wide SCSI cable from the Fast/Wide SCSI adapter.

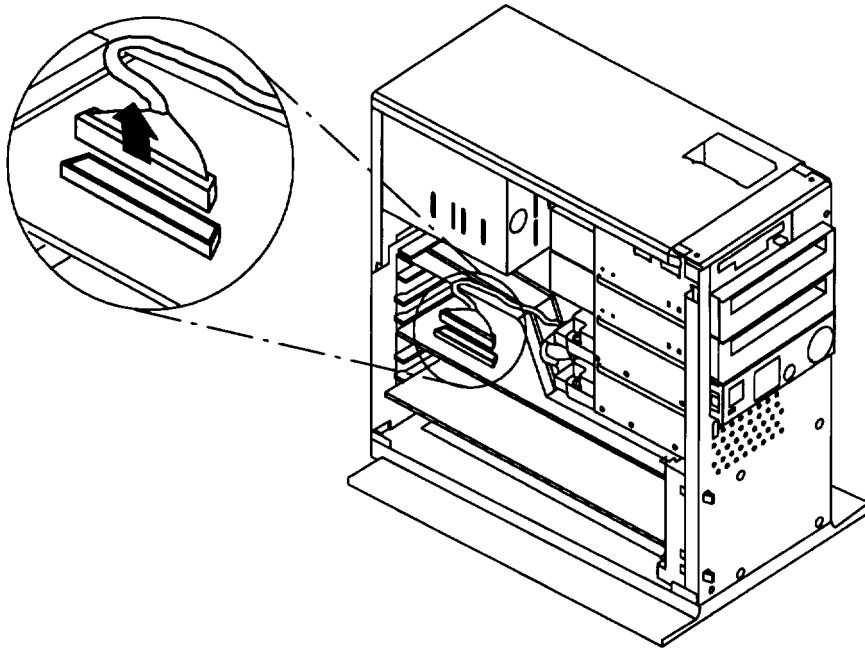

- b. Remove the Fast/Wide SCSI cable from the notch in the airflow baffle.

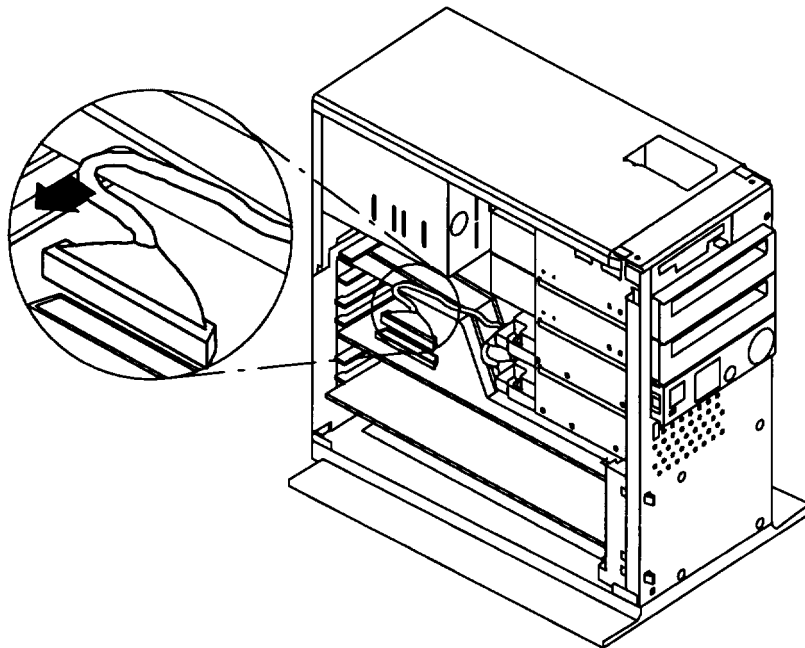

9. Remove the airflow baffle.

Warning: The airflow baffle must be installed before replacing the cover. Failure to replace the airflow baffle could result in damage to the system unit.

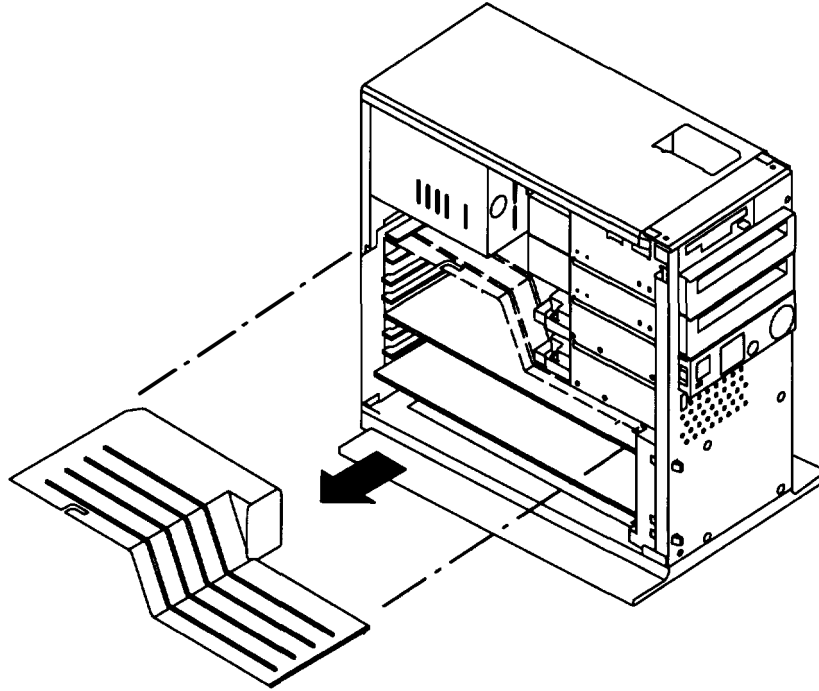

Replacement

1. Install the airflow baffle into its rails. You may have to arrange the internal cables to fully insert the airflow baffle.

Warning: The airflow baffle must be installed before replacing the cover. Failure to replace the airflow baffle could result in damage to the system unit.

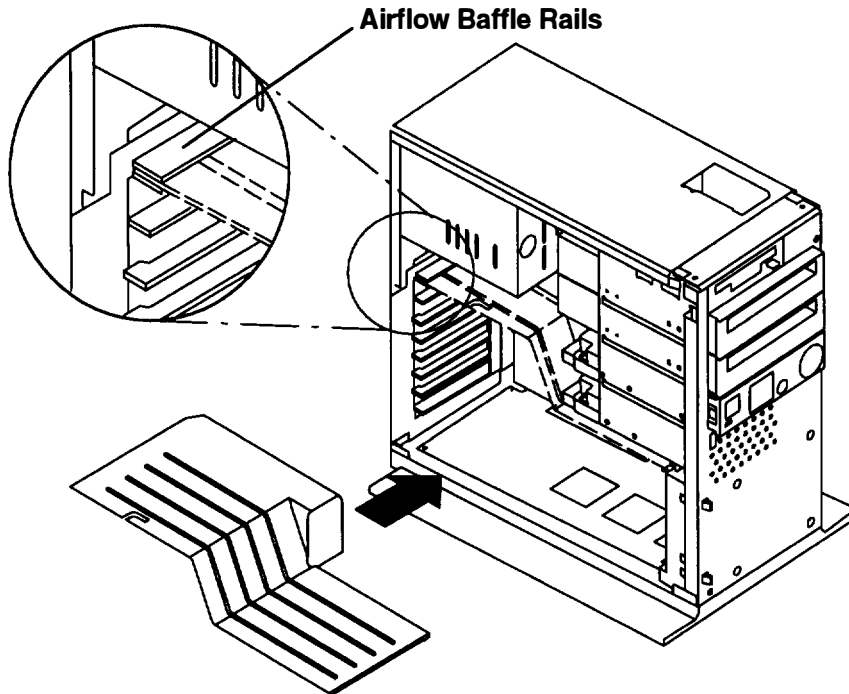

2. If the system unit contains a Fast/Wide SCSI adapter connected to internal Fast/Wide SCSI devices, then insert the Fast/Wide SCSI cable into the notch in the airflow baffle and connect the Fast/Wide SCSI cable to the Fast/Wide SCSI adapter.

Insert Fast/Wide SCSI Cable into Airflow Baffle Notch

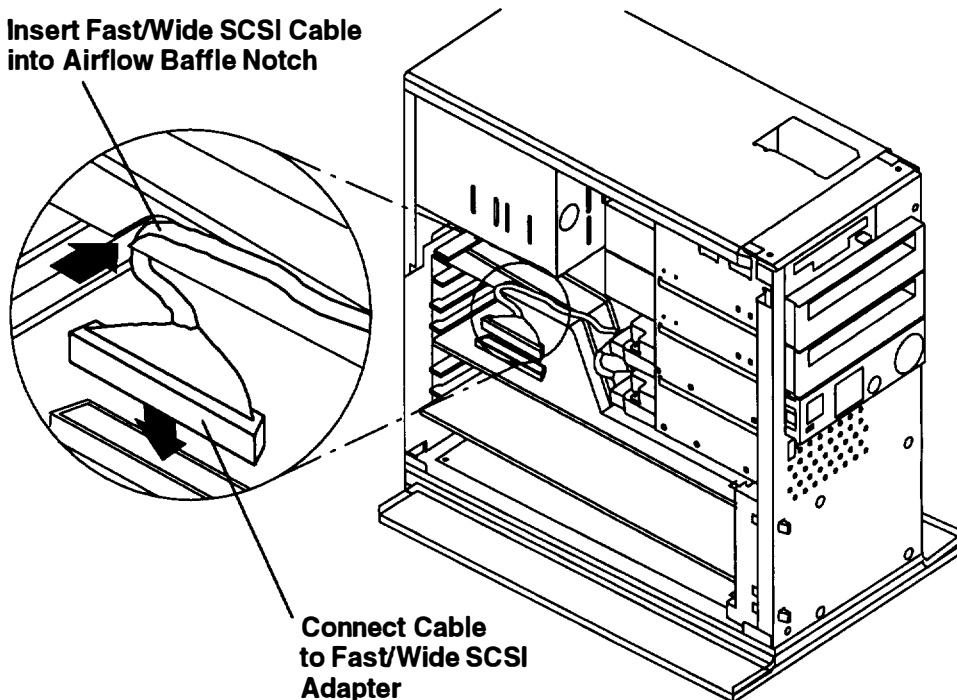

3. Slide the cover backward onto the chassis.

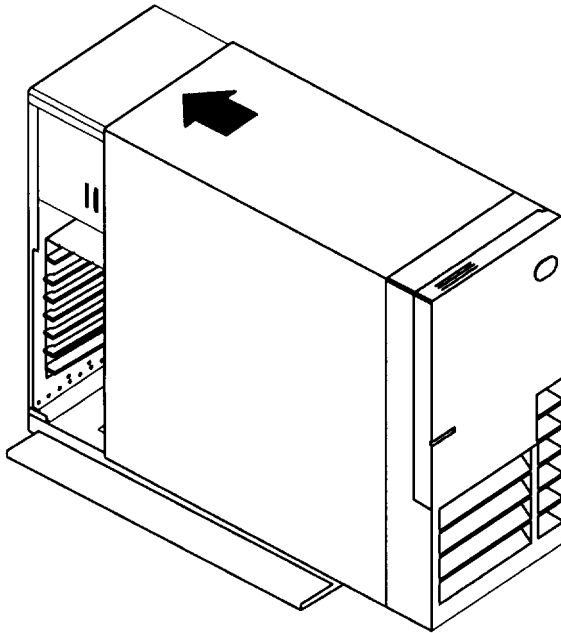

4. Open the door and insert the system unit keys into the key mode switch. If the cover is fully installed, you should be able to lock the cover onto the chassis by turning the key to the Secure or OK position.

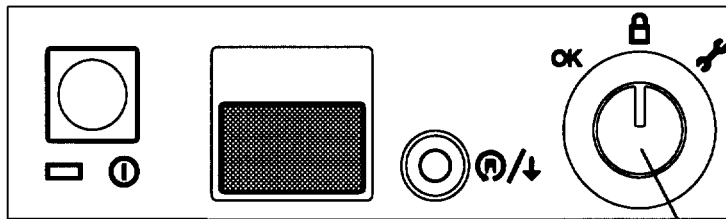

**Key Mode Switch
(Secure Position)**

Power Supply

DANGER

Do not attempt to open the covers of the power supply. Power supplies are not serviceable and are to be replaced as a unit.

Removal

1. Do the removal procedure in "System Unit Cover" on page 3-3.
2. Ensure that you have removed the power cord from the connector on the back of the system unit.
3. Remove the power supply cables from the connector on the back of each media device and disk drive.

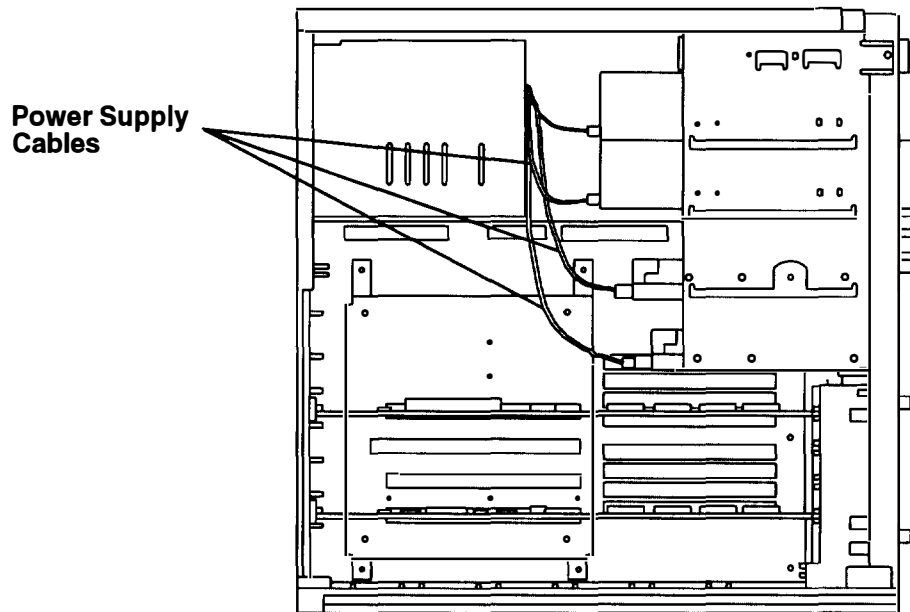

4. Unlatch the left side of the operator panel assembly, then the right side.

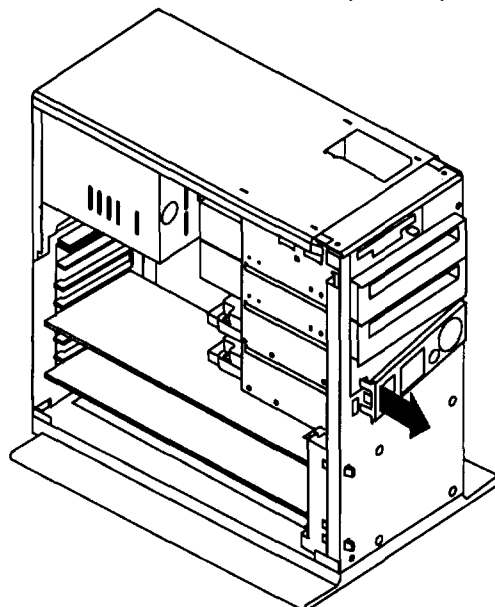

5. Remove the operator panel power supply cable from the back of the operator panel.
6. Remove the power supply cable from the connector on the system planar.

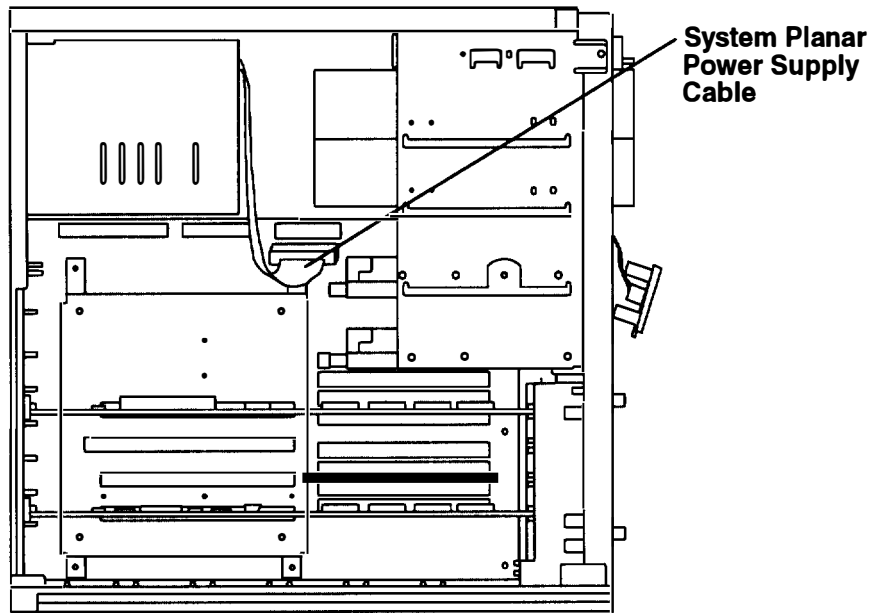

7. Gently lay the system unit down so the open side faces upward.

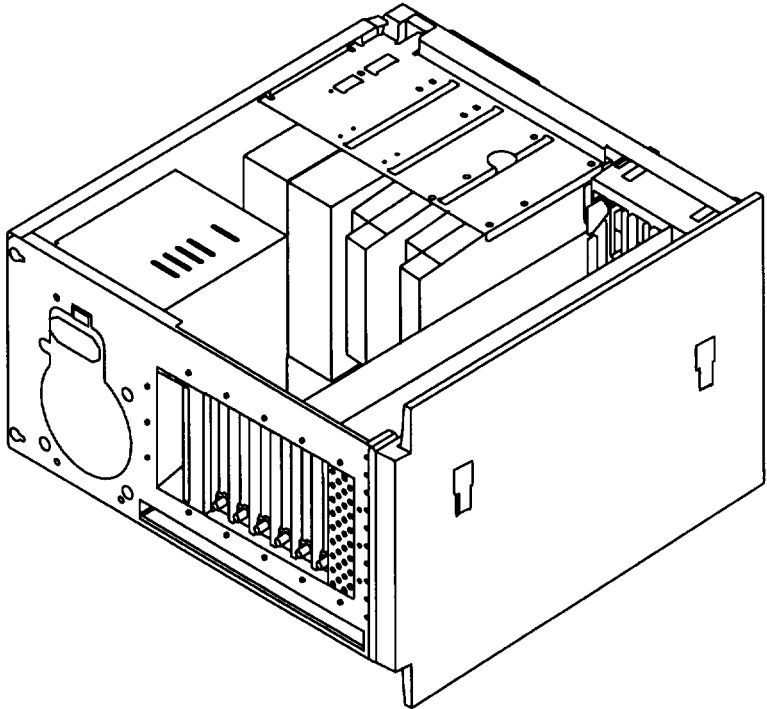

8. Remove the four screws that secure the power supply to the chassis.

**Power Supply
Screws**

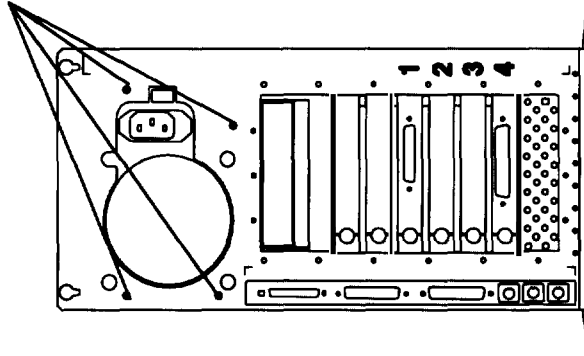

9. Move the power supply toward the front of the system unit, then remove the power supply from the system unit.

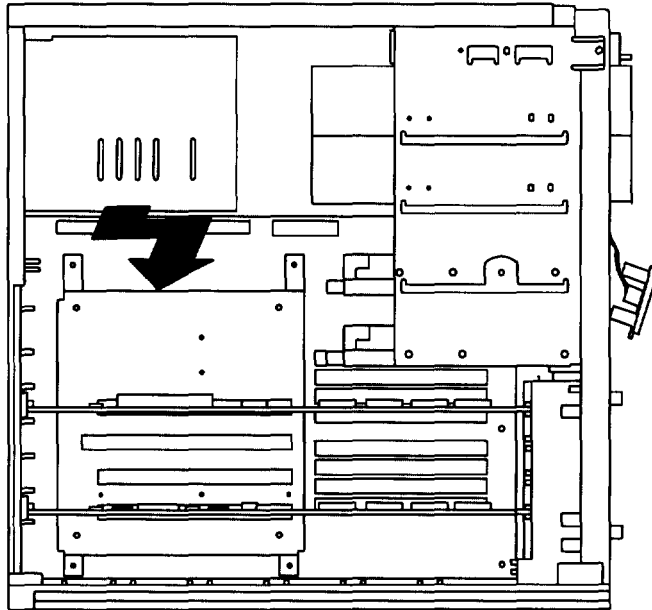

Replacement

To replace the power supply, perform the removal steps in the reverse order.

Note: Make sure the voltage switch setting matches the voltage provided by the electrical outlets.

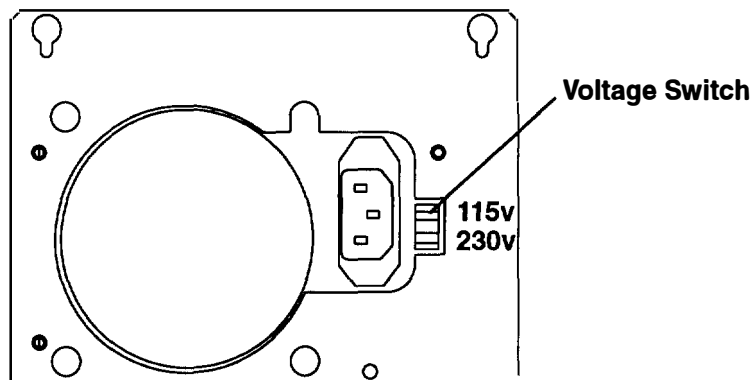

Diskette Drive

Removal

1. Do the removal procedure in "System Unit Cover" on page 3-3.
2. Remove the diskette drive cable from the back of the diskette drive.

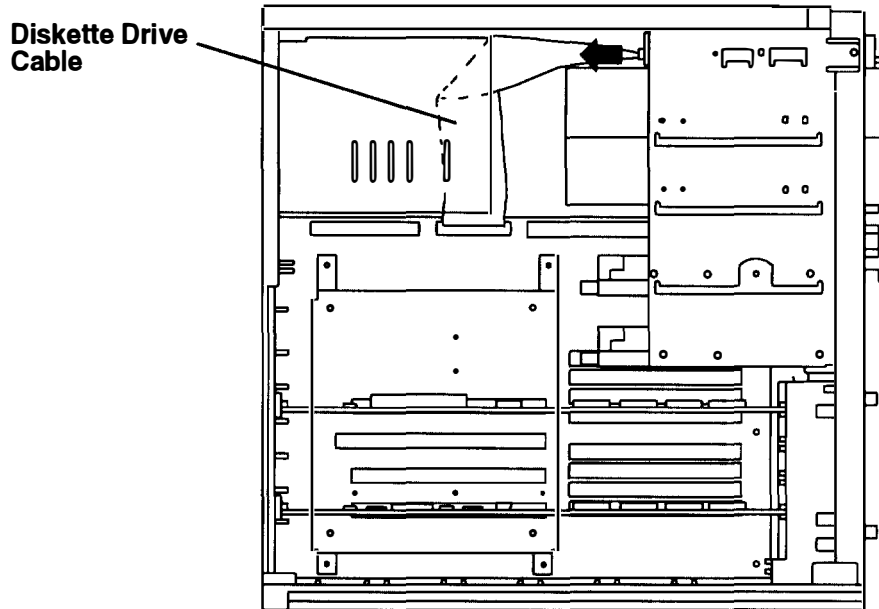

3. Remove the screws that hold the diskette drive inside the system unit.

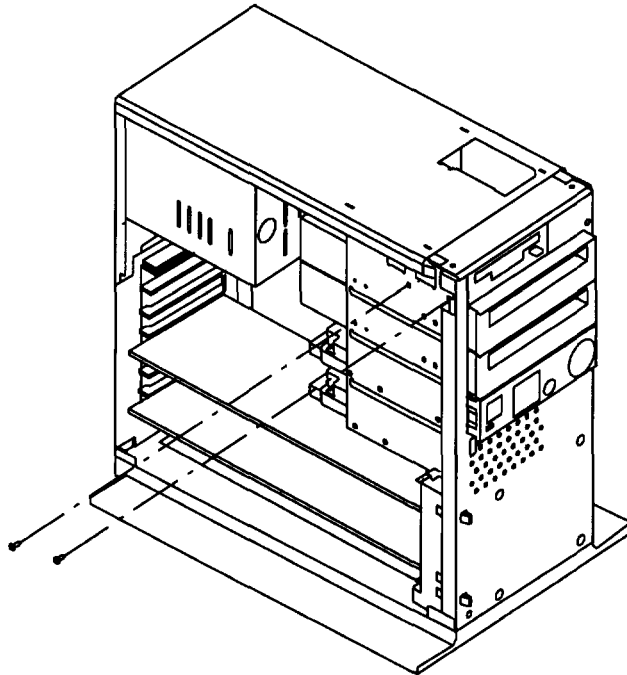

- Slide the diskette drive out of the system unit.

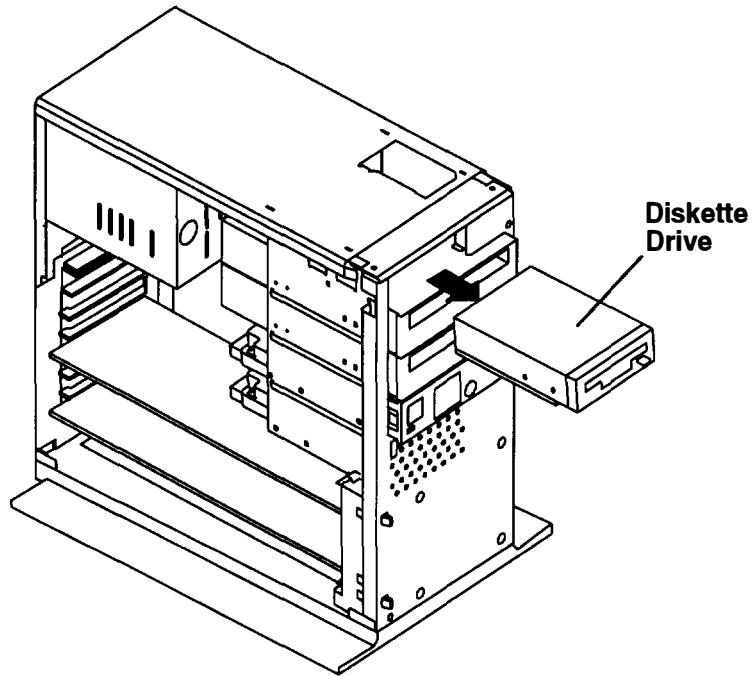

Replacement

To replace the diskette drive, do the removal steps in the reverse order.

Note: The screws that hold the diskette drive inside the system unit must be inserted into the holes indicated in the illustration.

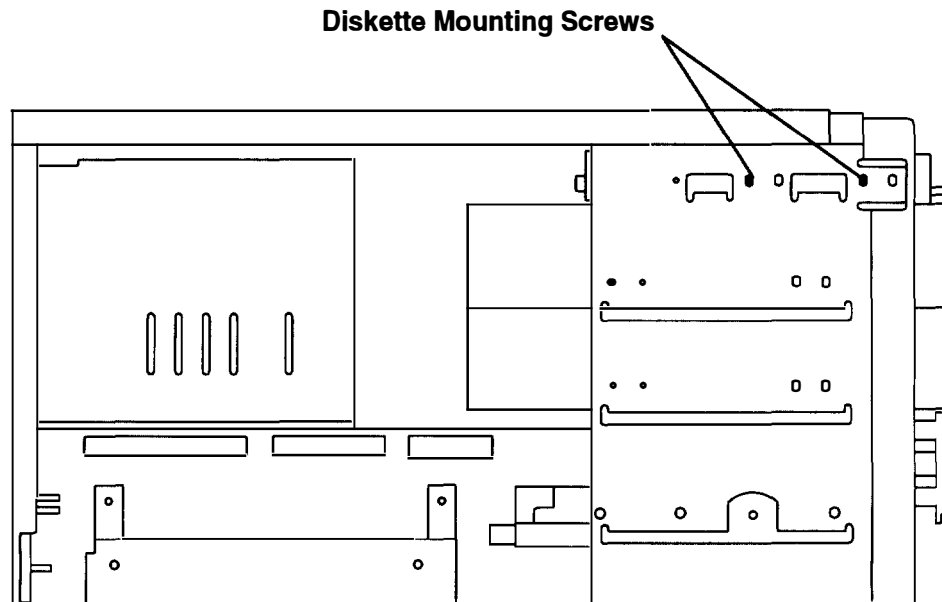

Media Drive

Note: For a translation of this notice, see *System Unit Safety Information*. This caution only applies to the CD-ROM drive.

CAUTION:

A class 3 laser may be contained in the device. Do not attempt to operate the drive while it is disassembled. Do not attempt to open the covers of the drive as it is not serviceable and is to be replaced as a unit.

Removal

1. Do the removal procedure in "System Unit Cover" on page 3-3.
1. Disconnect the cables from the back of the media drive.
2. Remove the four screws that hold the media drive inside the system unit.

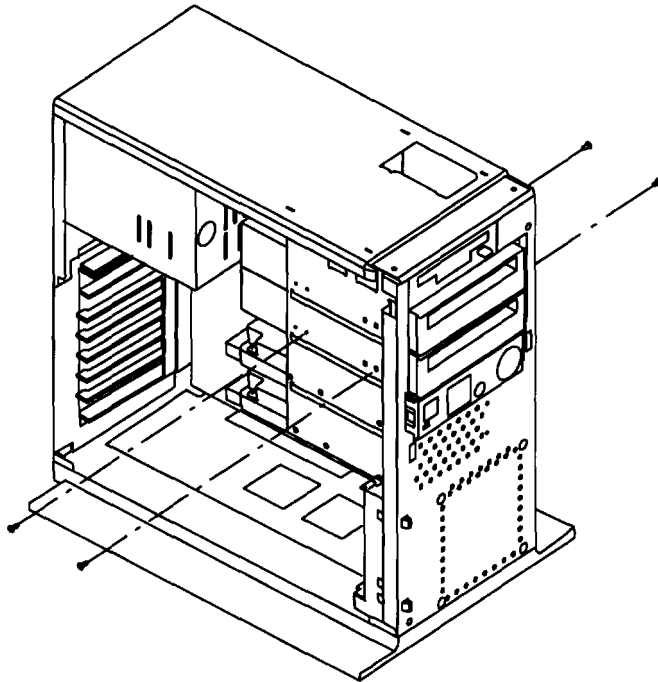

3. Slide the media drive forward and remove it from the system unit.

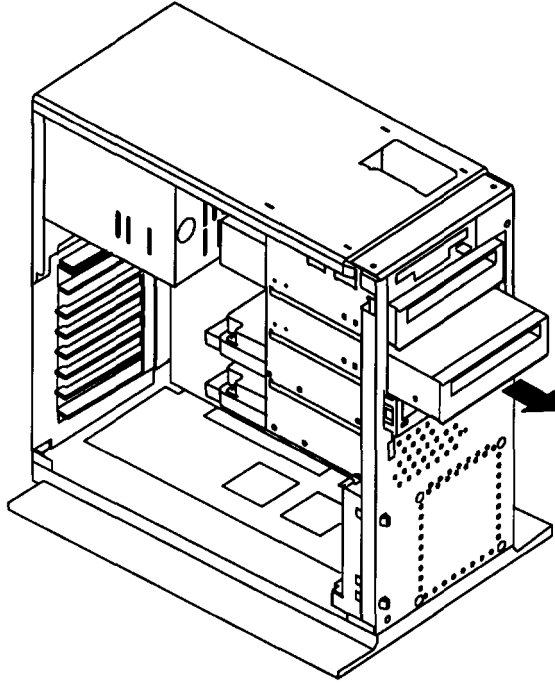

4. Record the jumper settings for the media drive you removed.

Replacement

1. Set the jumpers on the new media drive to match those on the removed media drive. For information on how to set the jumpers, see Chapter 9 of the *POWERstation and POWERserver Common Diagnostics Information Manual*.
2. Place the media drive on the mounting rails in an unoccupied media drive position.

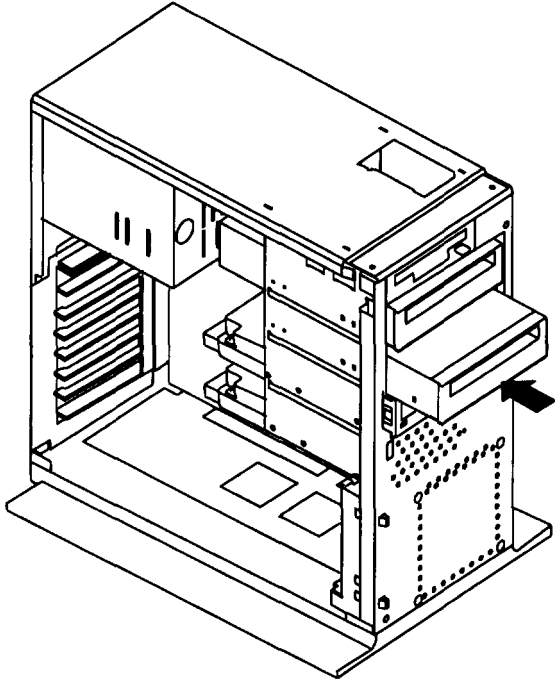

3. Connect the internal SCSI cable and power supply cable to the back of the media drive.
4. Slide the drive backward until the screw holes on the side of the drive line up with the holes in the side of the chassis.

5. Insert and tighten the four screws that hold the media drive inside the system unit.

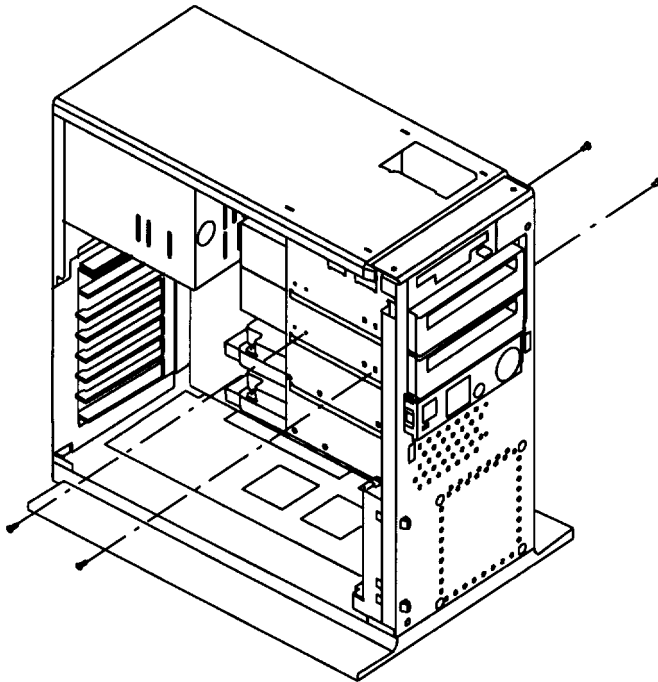

6. If no SCSI devices are connected to the SCSI connector, then make sure the system unit SCSI terminator is inserted into the system unit SCSI connector.

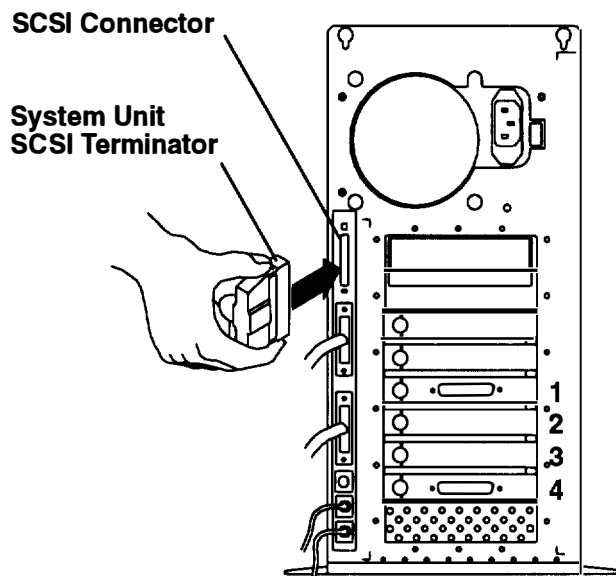

7. Do the replacement procedure in "System Unit Cover" on page 3-3.

Disk Drive

Removal

1. Do the removal procedure in "System Unit Cover" on page 3-3.
1. Disconnect the cables from the back of the disk drive.
2. If the disk drive is mounted in the upper or lower disk drive position, do the following:
 - a. Remove the disk drive mounting screws.

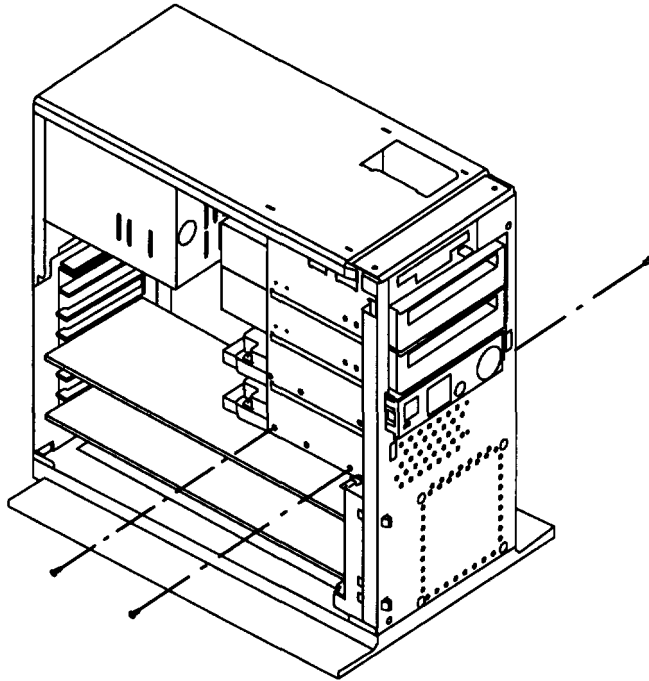

Note: The disk drive screws on the right side are recessed within the chassis. Move any cables aside to remove the disk drive's mounting screw.

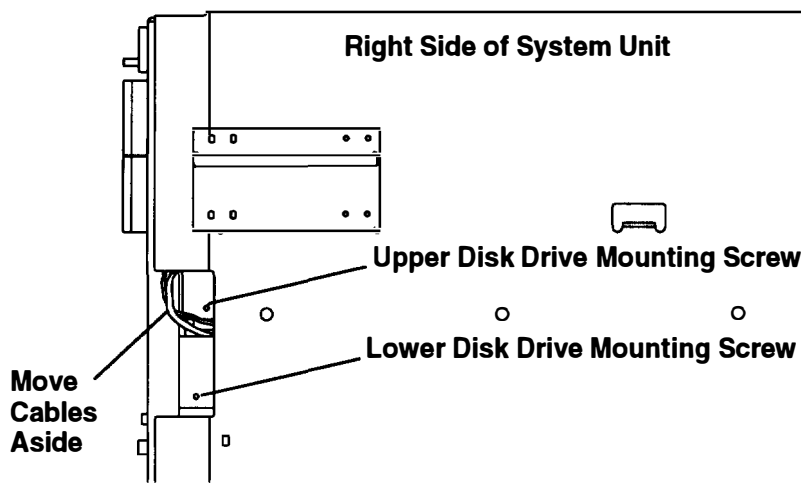

- b. Slide the disk drive backward and remove it from the system unit.

3. If the disk drive is mounted in the upper or lower media position, do the following:
 - a. Remove the disk drive mounting screws.

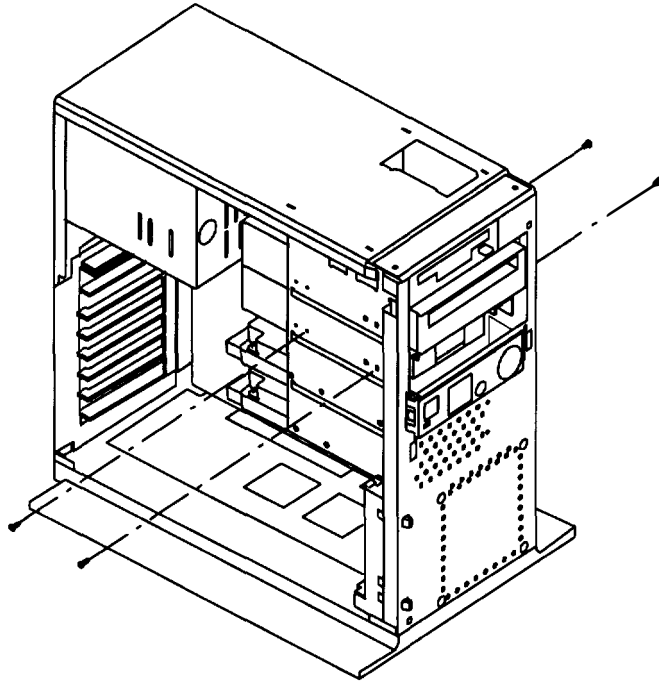

- b. Slide the disk drive forward and remove it from the system unit.
 - c. Remove the mounting brackets from the old disk drive.

Mounting Brackets

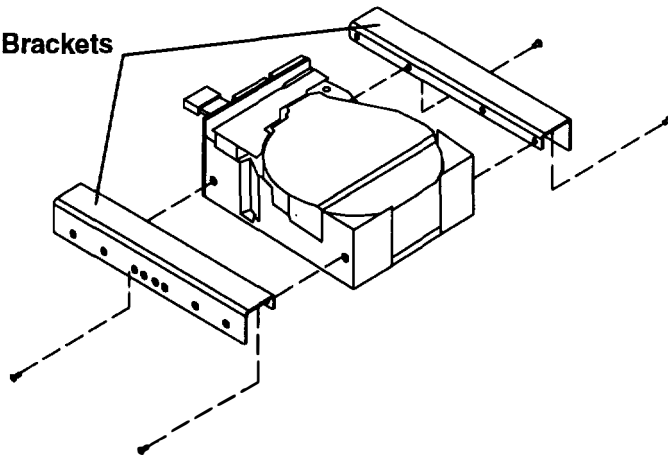

4. Record the jumper settings (SCSI address) for the disk drive you removed.

Replacement

1. Set the jumpers on the new disk drive to match those on the removed disk drive. The following illustration and table are included for reference. For more information about these disk drives, see the *Adapters, Devices, and Cable Information*.

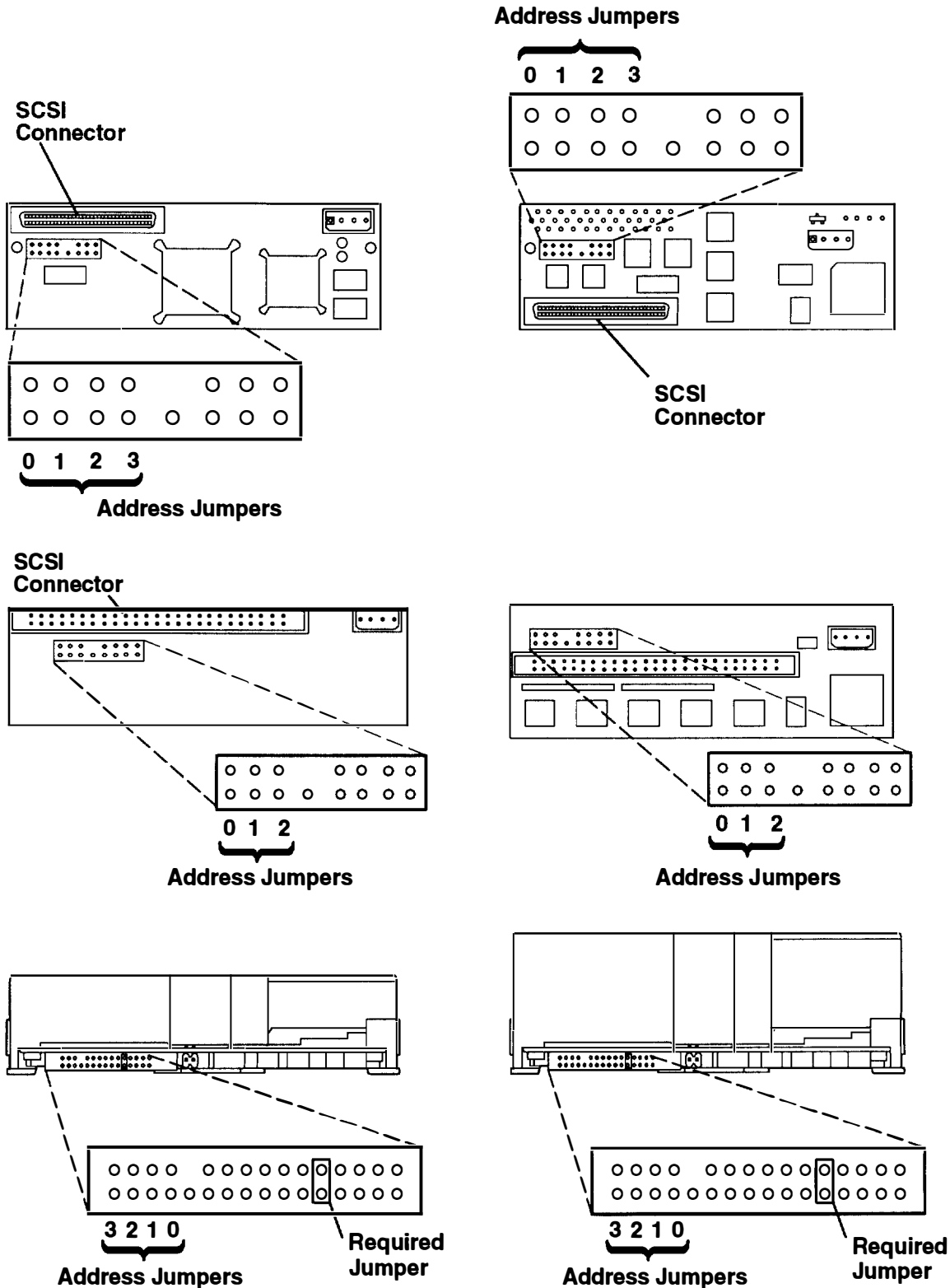

Notes:

- The following table shows the jumper settings for each SCSI address. Before you set jumpers to assign the disk drive's SCSI address, consult the SCSI address record in Appendix A to make sure the address you assign is unique.
- SCSI address 5 is recommended for disk drives installed in the upper media position. SCSI address 6 is recommended for disk drives installed in the lower media position. SCSI address 1 is recommended for disk drives installed in the upper disk position. SCSI address 0 is recommended for disk drives installed in the lower disk position.
- Address 7 is usually reserved for the adapter; however, in high-availability configurations, the second adapter is usually assigned address 6.
- An optional Fast/Wide SCSI adapter can be used with Fast/Wide SCSI disk drives, which use Jumper 3 to set SCSI addresses up to 15.

SCSI Address	Jumper 3	Jumper 2	Jumper 1	Jumper 0
0	Off	Off	Off	Off
1	Off	Off	Off	On
2	Off	Off	On	Off
3	Off	Off	On	On
4	Off	On	Off	Off
5	Off	On	Off	On
6*	Off	On	On	Off
7*	Off	On	On	On
8	On	Off	Off	Off
9	On	Off	Off	On
10	On	Off	On	Off
11	On	Off	On	On
12	On	On	Off	Off
13	On	On	Off	On
14	On	On	On	Off
15	On	On	On	On

2. If you are mounting a disk drive in the upper or lower disk drive position, place the disk drive on the mounting rails.

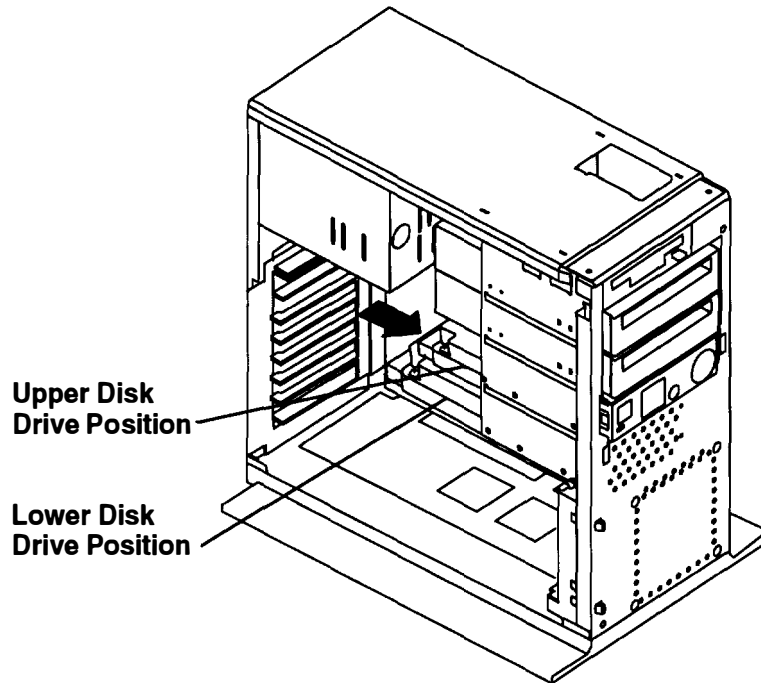

3. If you are mounting a disk drive in the upper or lower media position, then attach the mounting brackets to the disk drive as shown, and place the entire assembly in the media position within the system unit.

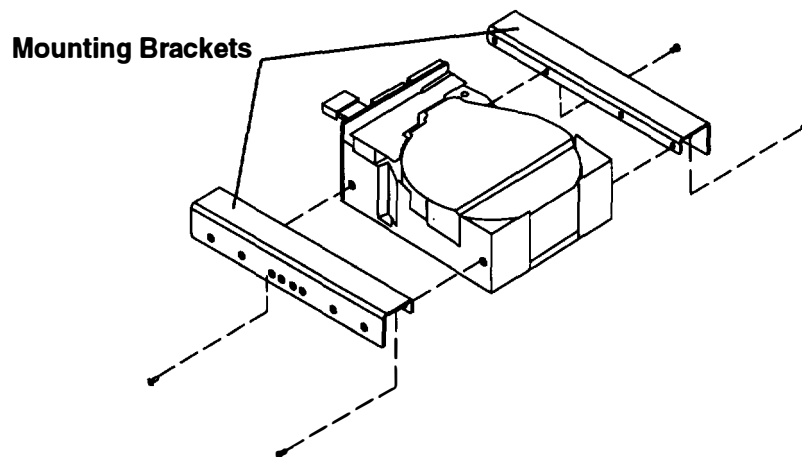

4. If the disk drive you are installing is a Fast/Wide SCSI device which you will connect to an optional Fast/Wide SCSI adapter, then connect the Fast/Wide SCSI cable to the back of the disk drive now.

Note: Do not attach the cable to the Fast/Wide SCSI adapter. You will attach the cable to the Fast/Wide SCSI adapter just before replacing the system unit cover.

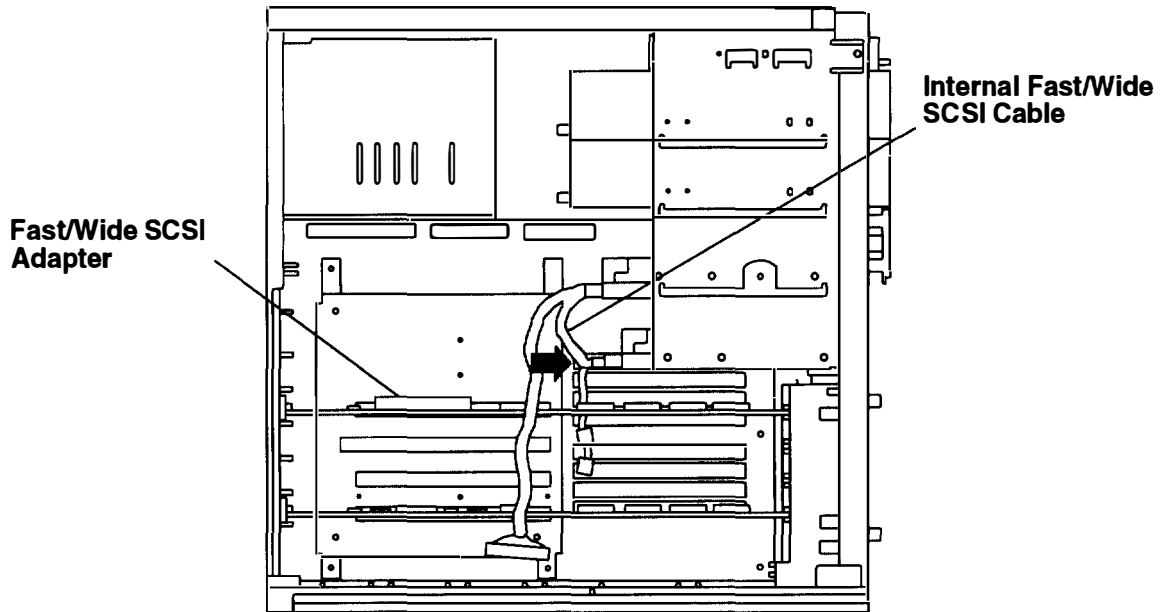

5. If you will connect the disk drive to the *built-in* SCSI adapter, then locate the connector on the internal SCSI cable that corresponds to the position in which you have installed the disk drive. Connect the internal cable to the back of the disk drive.

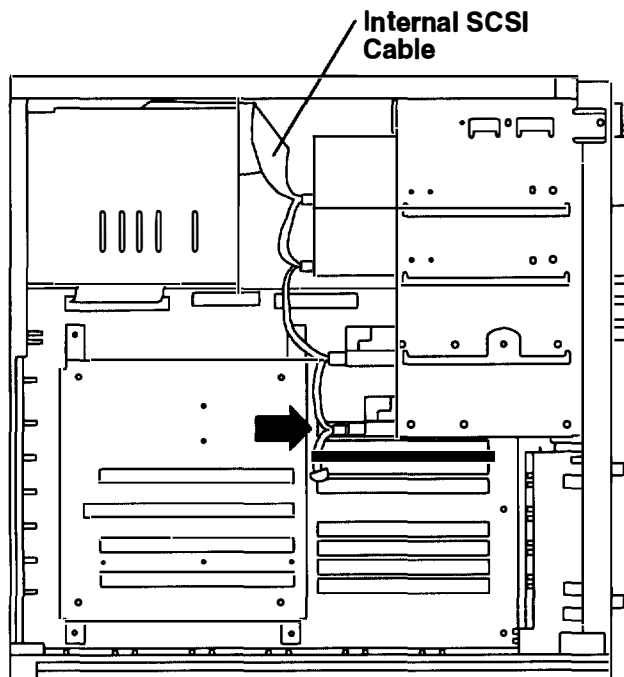

6. Locate an unused power supply cable of appropriate length and attach it to the power connector on the back of the disk drive. If no unused power supply cables are long enough to reach the new disk drive, exchange an unused power supply cable with a longer power supply cable already attached to a drive.

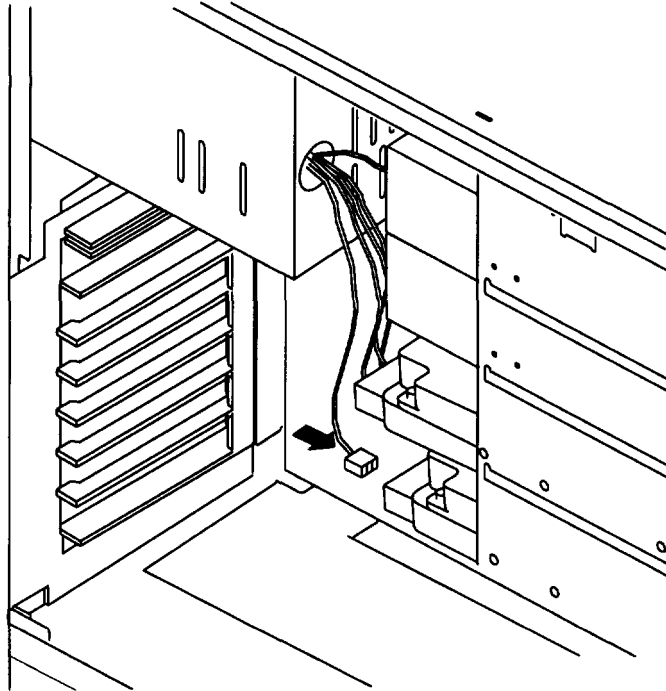

7. Slide the drive forward until the screw holes on the side of the drive line up with the holes in the side of the chassis.
8. If you are installing a disk drive in the lower disk position or the upper disk position, insert and tighten the three disk drive mounting screws.

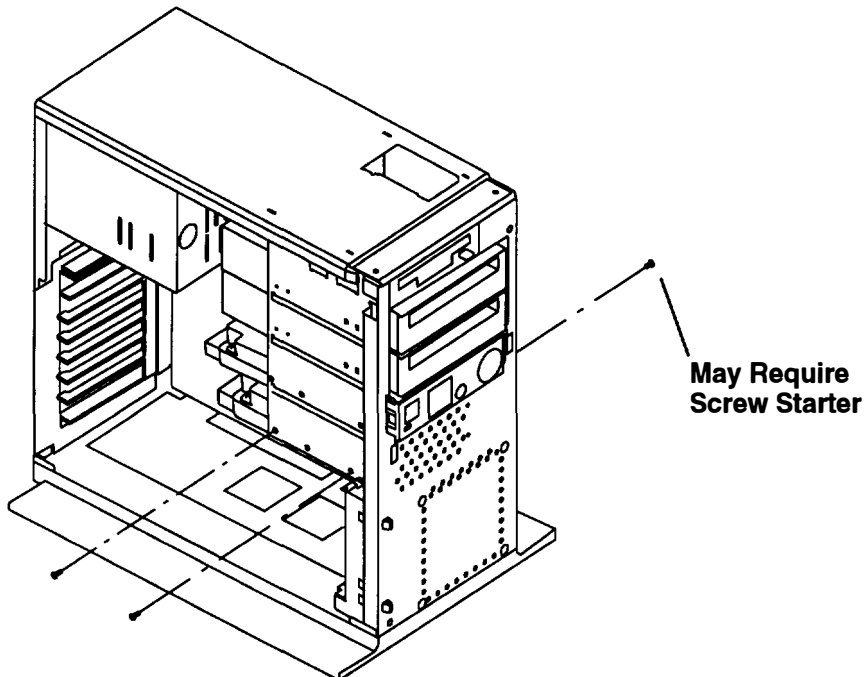

Note: The disk drive screw holes on the right side are recessed within the chassis. Move any cables aside to clear the screw hole, then insert and tighten the screw for the disk drive you are installing. You may need a screw starter to insert the screw.

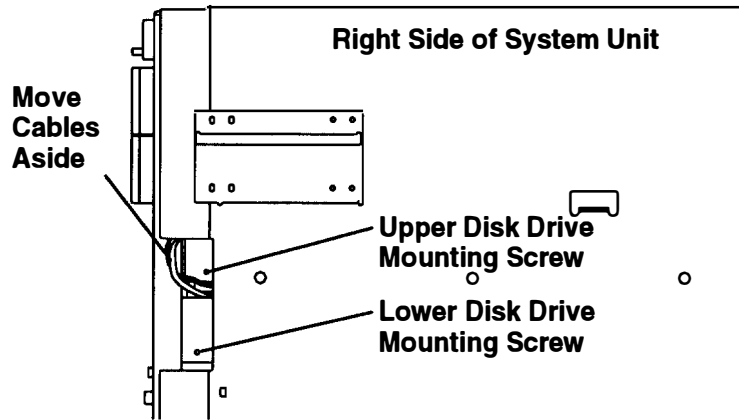

9. If you are installing a disk drive in the upper or lower media position, lift the disk drive so that a set of holes in the mounting brackets matches the mounting holes in the system unit chassis. Insert and tighten the four mounting screws as shown.

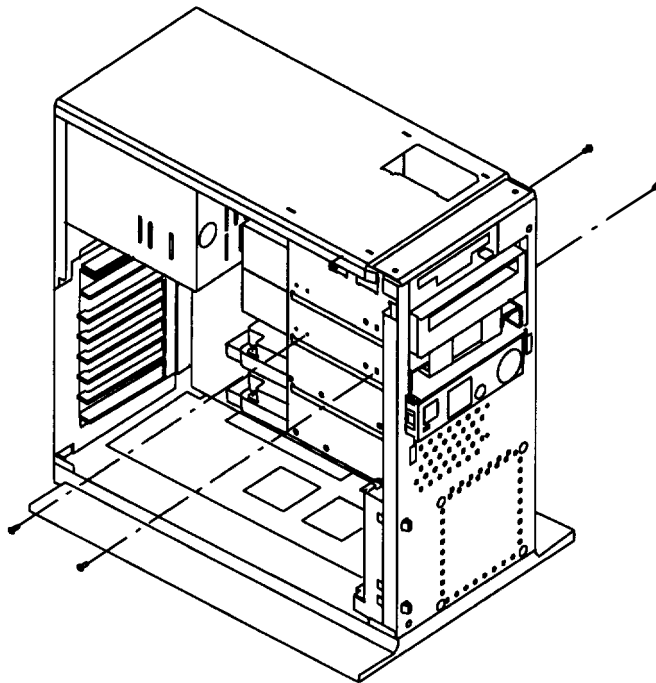

10. If no SCSI devices are connected to the external SCSI connector, then make sure the system unit SCSI terminator (Part Number 51G7737) is inserted into the system unit SCSI connector.

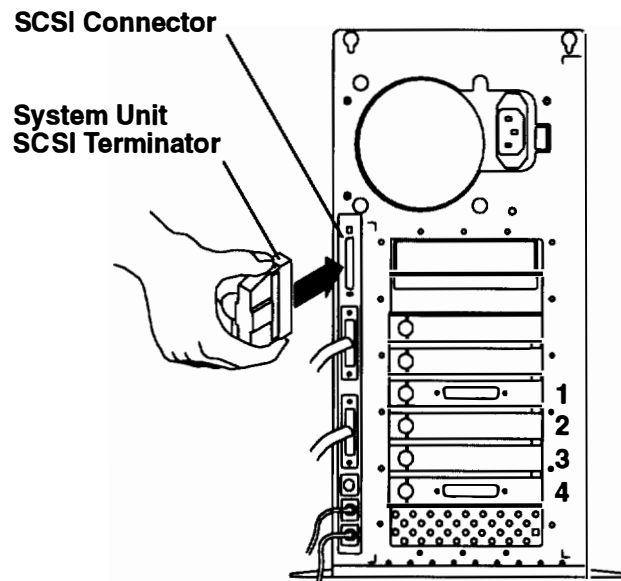

11. Do the replacement procedure in "System Unit Cover" on page 3-3.

Internal SCSI Cable

Removal

1. Do the removal procedure in "System Unit Cover" on page 3-3.
2. Do the removal procedure in "Power Supply" on page 3-8.
3. Disconnect the internal SCSI device cable from the backs of all disk drives and media devices.

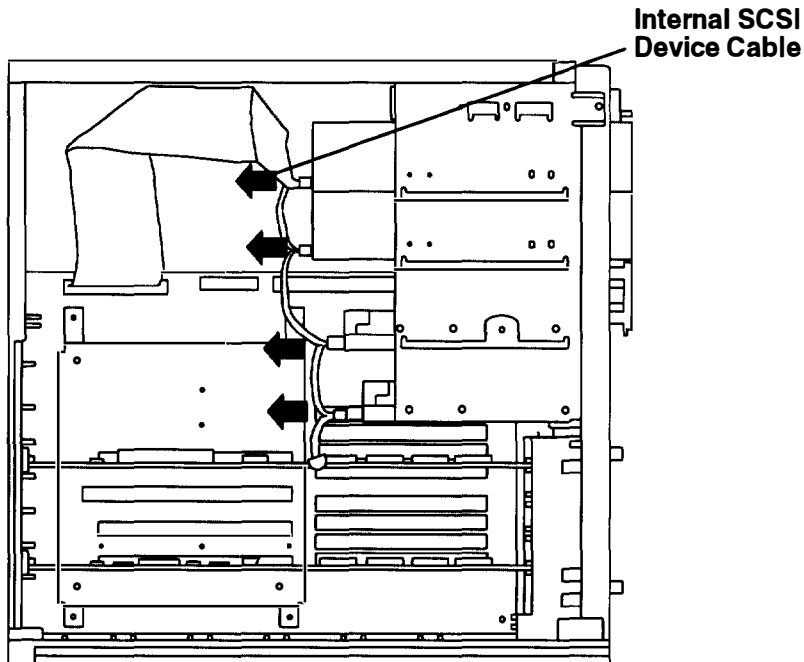

4. Disconnect the internal SCSI device cable from the system planar SCSI connector

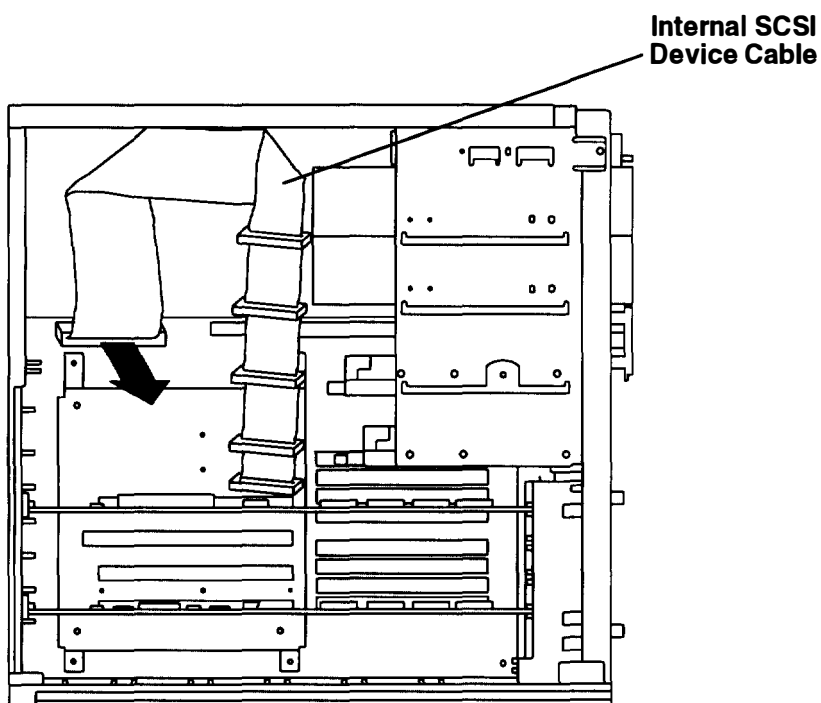

Replacement

1. Route the internal SCSI cable as shown in the illustration, and connect the SCSI cable to the connector on the system planar.

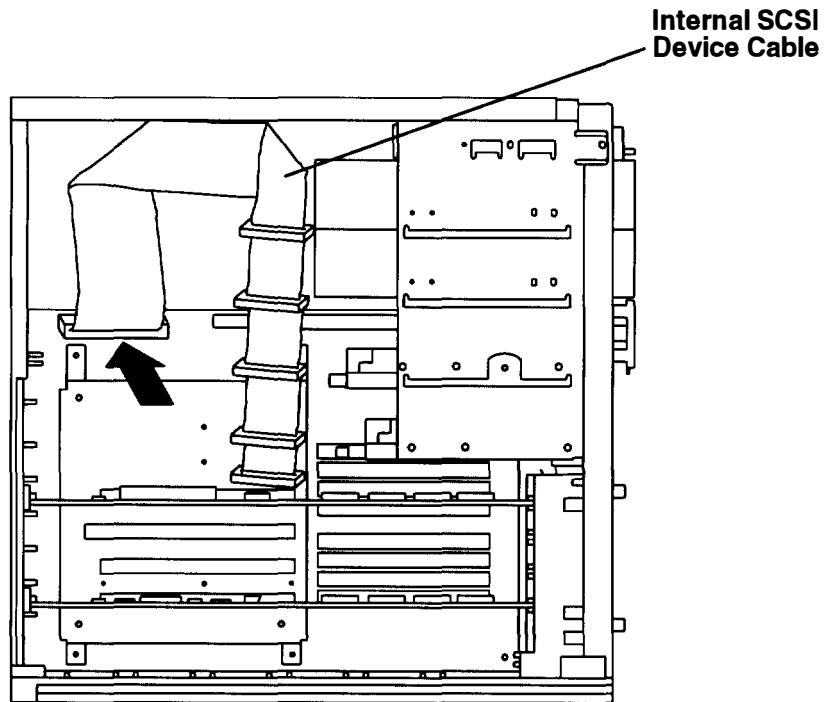

2. Connect the internal SCSI device cable to the backs of all disk drives and media devices.

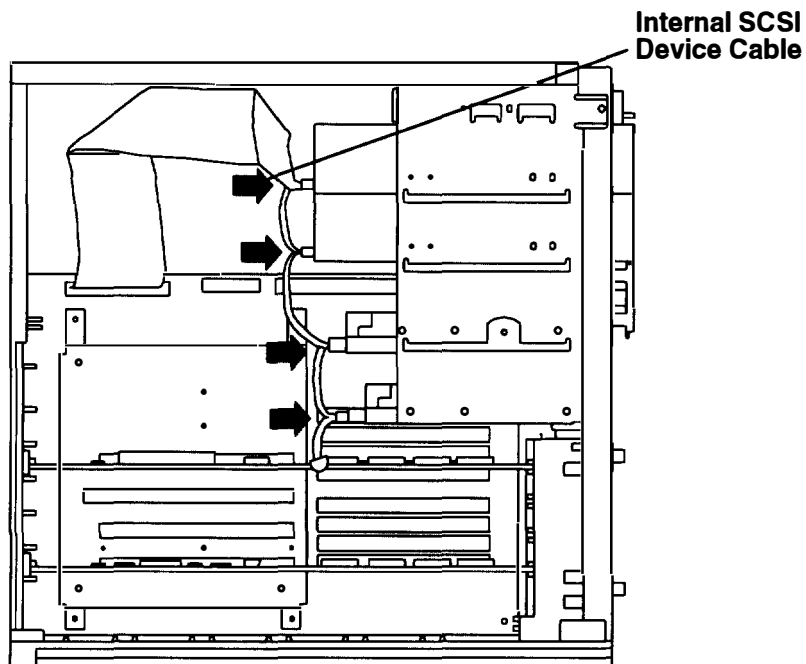

3. Do the replacement procedure in "Power Supply" on page 3-8.
4. Do the replacement procedure in "System Unit Cover" on page 3-3.

Adapters

Removal

1. Do the removal procedure in "System Unit Cover" on page 3-3.
2. Remove the cable attached to the adapter. For quick reattachment later, you may want to label the cable as you remove it.
3. Loosen the serrated knob on the slot containing the adapter.

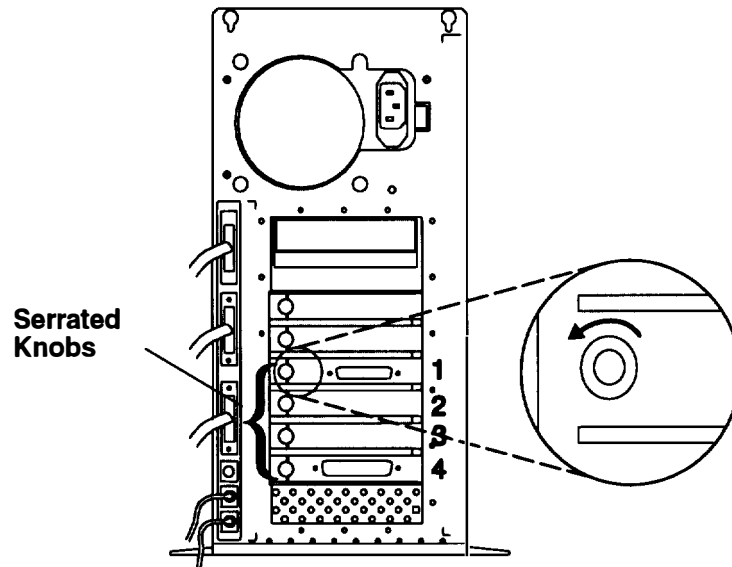

4. Gently lay the system unit down so that the open side faces upward.

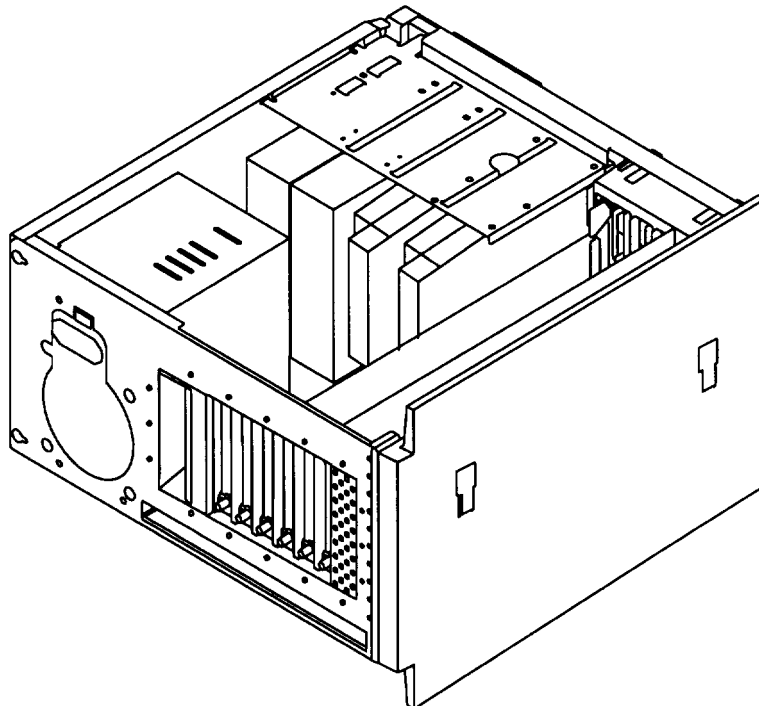

5. Remove the adapter from the system unit by pulling upward. If a Type 3 card fastener is installed in the front card guide, press the adapter toward the bottom of the system unit before pulling upward.

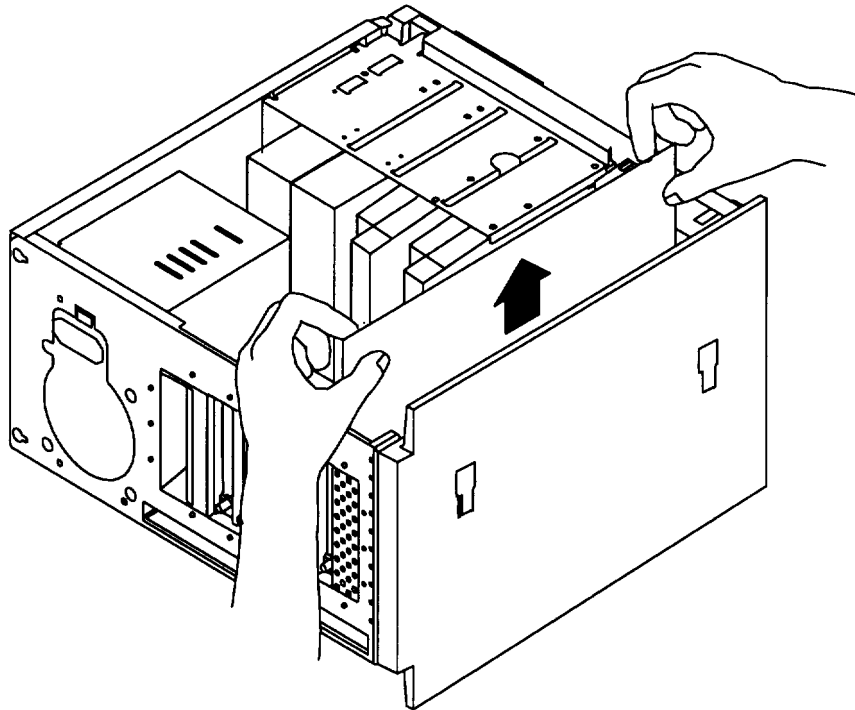

Replacement

To replace the adapter, do the removal procedures in the reverse order.

Note: If replacing Fast/Wide SCSI adapters, the first Fast/Wide adapter must be installed in slot 1, the second in slot 2, and so on.

Memory

Removal

1. Do the removal procedure in "System Unit Cover" on page 3-3.
2. If you need to remove SIMM set 0 and a disk drive is installed in the lower disk drive position, do the removal procedure in "Disk Drive" on page 3-13 to remove the lower disk drive.

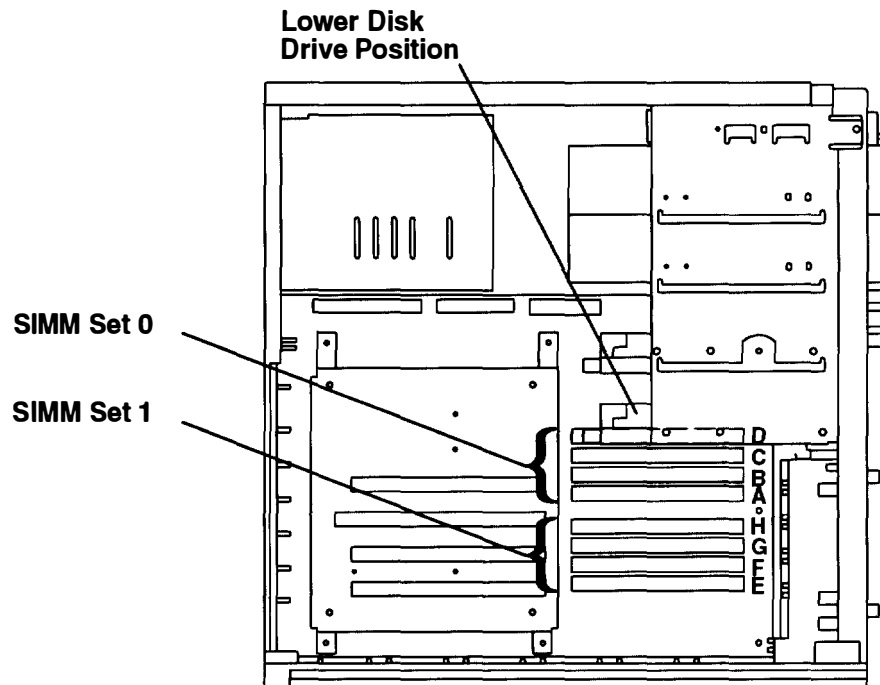

3. If adapters are installed, do the removal procedure in "Adapters" on page 3-27.
4. Gently lay the system unit down so that the open side faces upward.

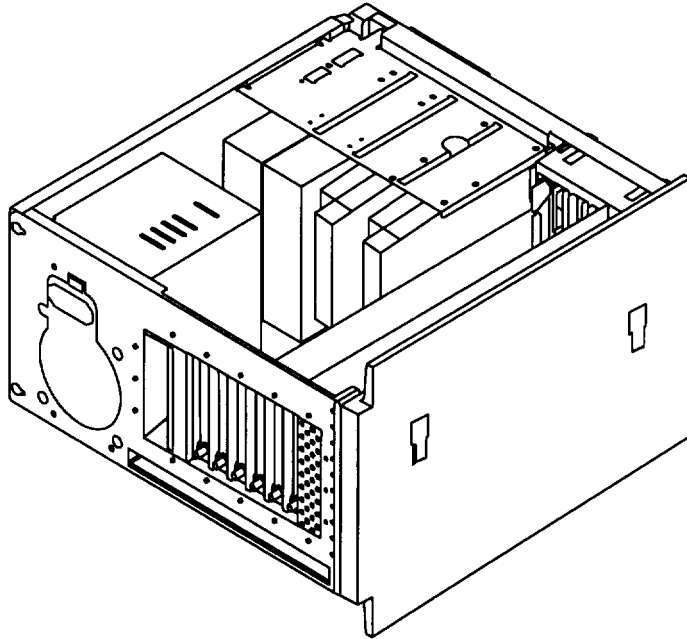

5. To remove previously installed SIMMs:

- a. Within the set of four SIMMs, start with the SIMM closest to the top of the system unit. Press the locking tabs outward.

Press Tabs Outward

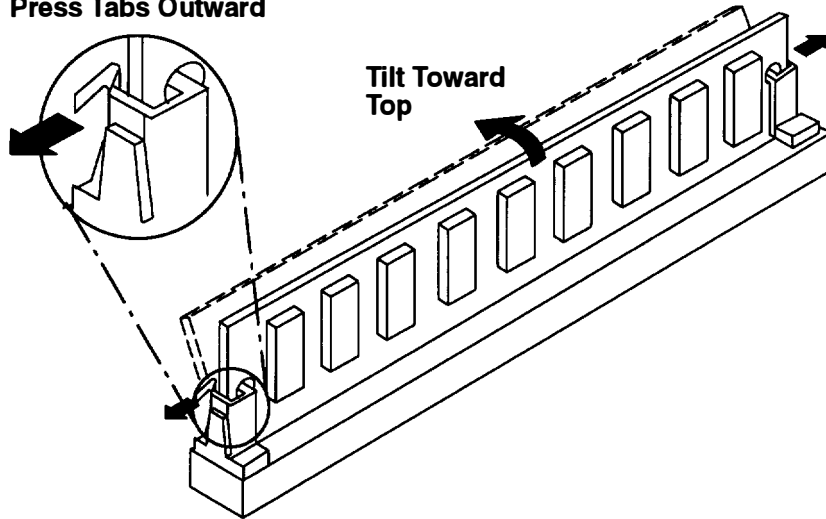

- b. Tilt the SIMM toward the top of chassis and pull it out of the socket.

Replacement

Note: SIMMs must be installed in matching sets of four.

1. With one hand, touch any metal surface of the chassis to minimize static electrical charges, and then pick up a SIMM.
2. Locate the SIMM sockets on the system planar.

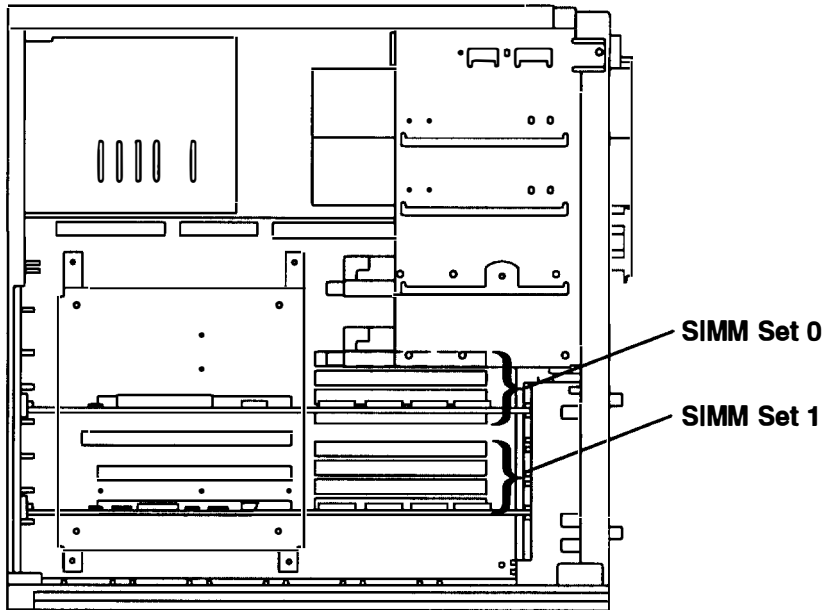

3. To install new SIMMs, turn the SIMM so that the notch is to the right (closest to the front of the system unit).

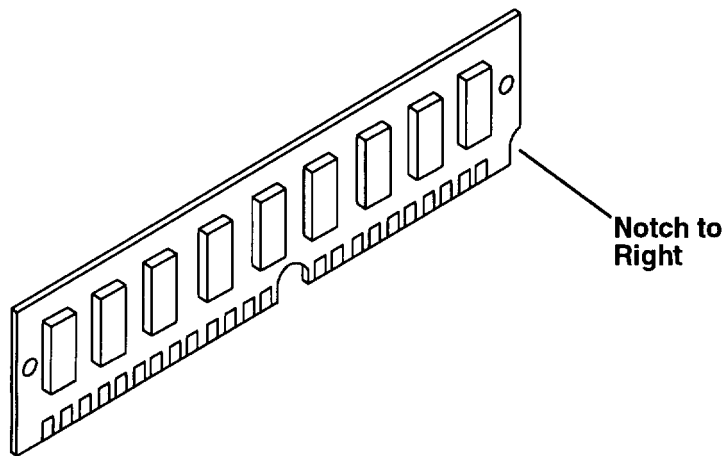

4. Starting with the lowest slot in the set of four, insert a SIMM at an angle and tilt the SIMM upright until the locking tabs snap into place to hold the SIMM.

Repeat this step until you have installed the complete set of four matching SIMMs. Replace the SIMMs from bottom to top within the set of four so each SIMM will not interfere with the others when tilted into position.

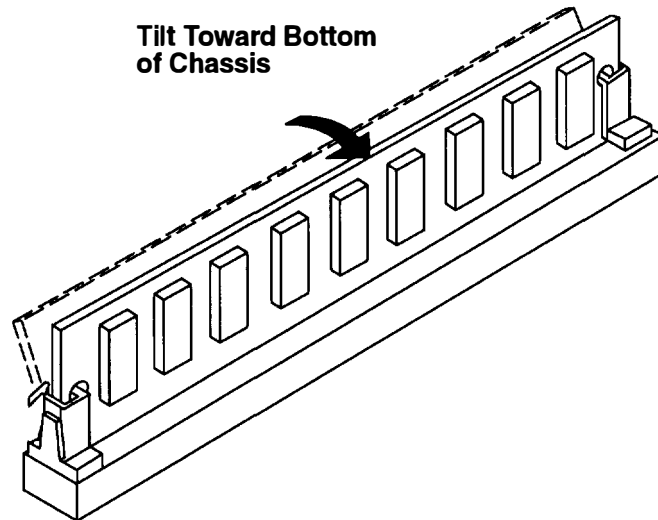

5. Do the replacement procedure in "Adapters" on page 3-27 if you have removed any adapters.
6. Do the replacement procedure in "Disk Drive" on page 3-13 if you have removed the lower disk drive.
7. Do the replacement procedure in "System Unit Cover" on page 3-3.

Level-2 Cache Card

Removal

1. Do the removal procedure in "System Unit Cover" on page 3-3.

Note: It is not necessary to remove the air-flow baffle in order to replace the Level-2 Cache card.

2. Loosen the connector screws on the Level-2 Cache card.

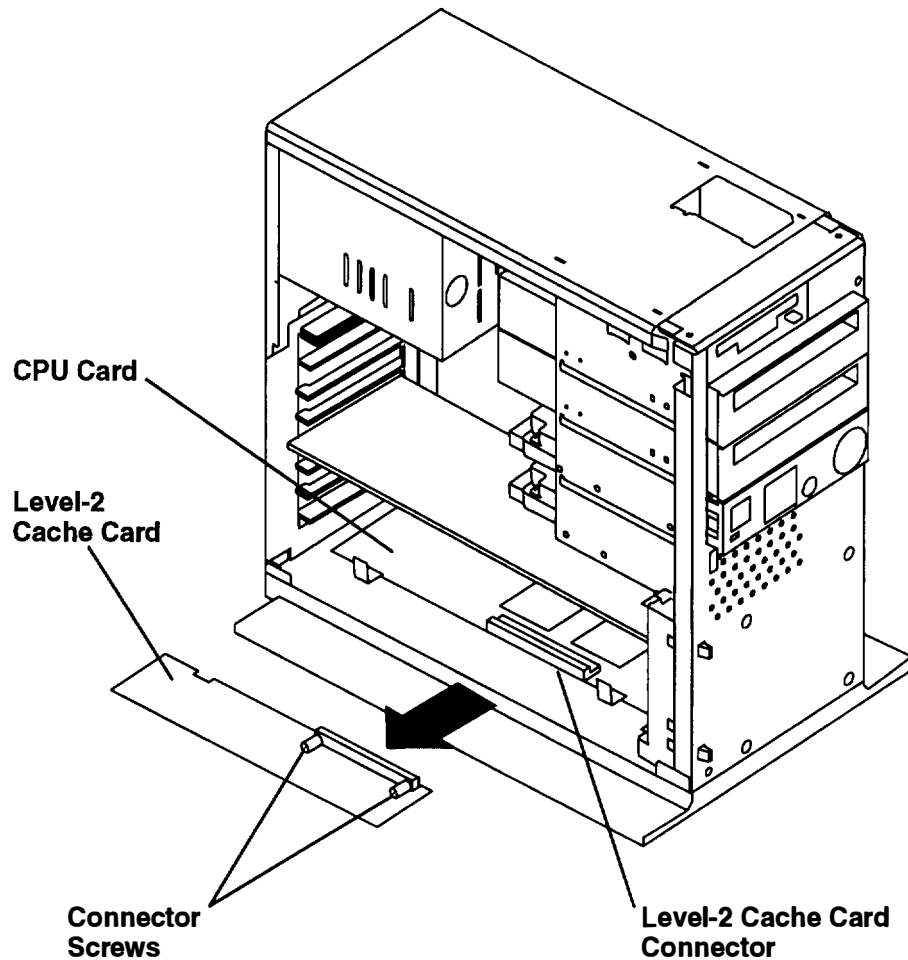

3. Remove the Level-2 Cache card from the connector on the CPU card.

Replacement

To replace the Level-2 Cache card, do the removal steps in the reverse order.

CPU Card

Removal

1. Do the removal procedure in "System Unit Cover" on page 3-3.

Note: It is not necessary to remove the airflow baffle in order to replace the CPU card.

2. If a Level-2 Cache card is installed, do the removal procedure in "Level-2 Cache Card" on page 3-33.
3. Remove the screw that attaches the CPU card bracket, then remove the CPU card bracket.

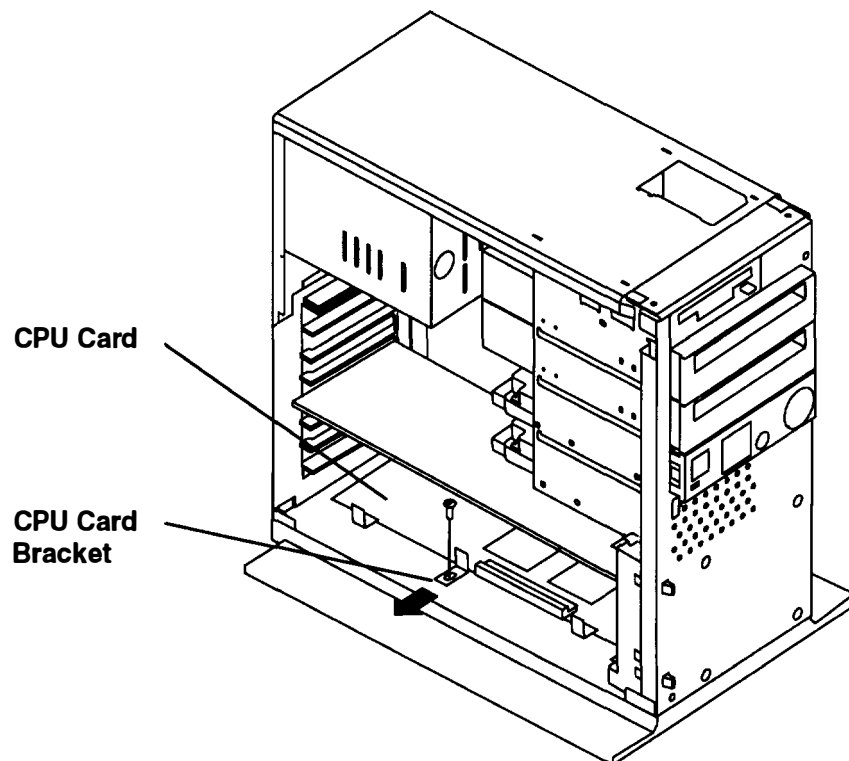

4. To remove the CPU card, pull outwards on the CPU card pull tabs.

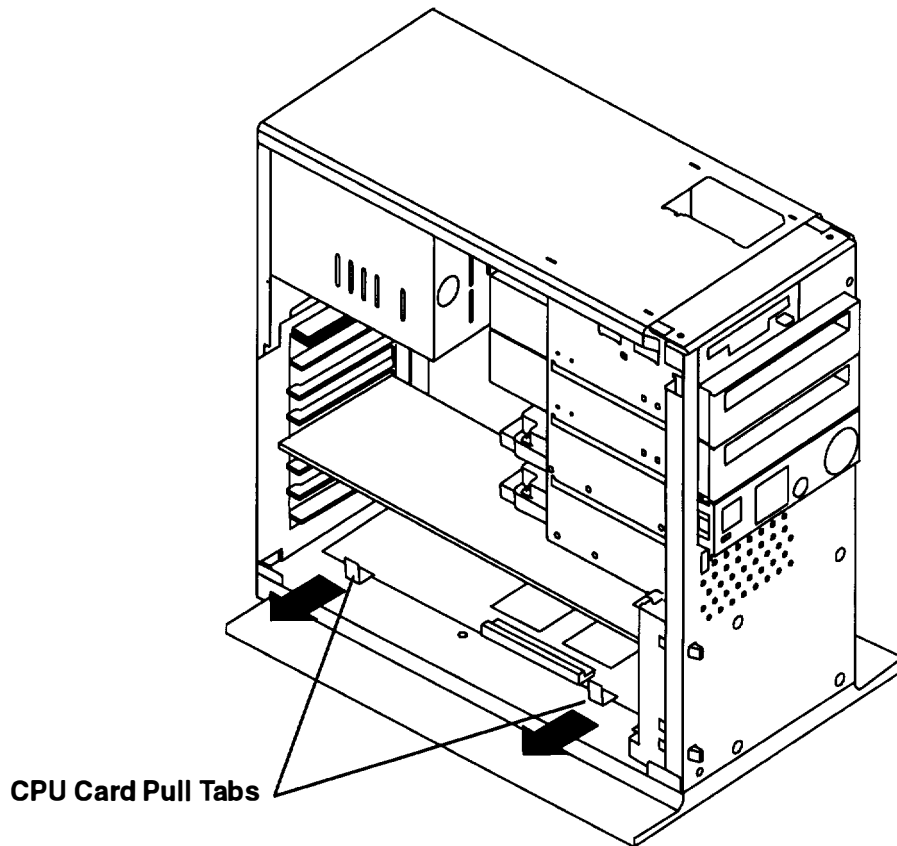

Replacement

To replace the CPU card, do the removal steps in the reverse order.

Note: The nonvolatile random access memory (NVRAM) in the new CPU card may contain system records that do not match your current system. To erase these records, you can remove the battery and briefly connect the positive and negative terminals of the battery clip with a metal screwdriver or paper clip. You can then replace the battery and continue setting up your system. The next time the system boots, the operating system will detect that the NVRAM records have been erased and construct new NVRAM records based on your current system configuration.

Reminder to Service Representative: After you exchange the CPU card, notify the customer that:

- The unique identification number of the system unit has changed. The customer needs to update the authorization number for any program that uses the identification number for access.
- The system unit clock must be set to the correct time. The system clock must be set correctly so that automated programs will run at the desired times.

Operator Panel

Removal

1. Do the removal procedure in "System Unit Cover" on page 3-3.
2. If a disk drive is installed in the upper disk drive bay, do the removal procedure in "Disk Drive" on page 3-13.
3. Remove the keylock cable attached to the system planar at J4 and remove the three-digit display cable attached at J7.

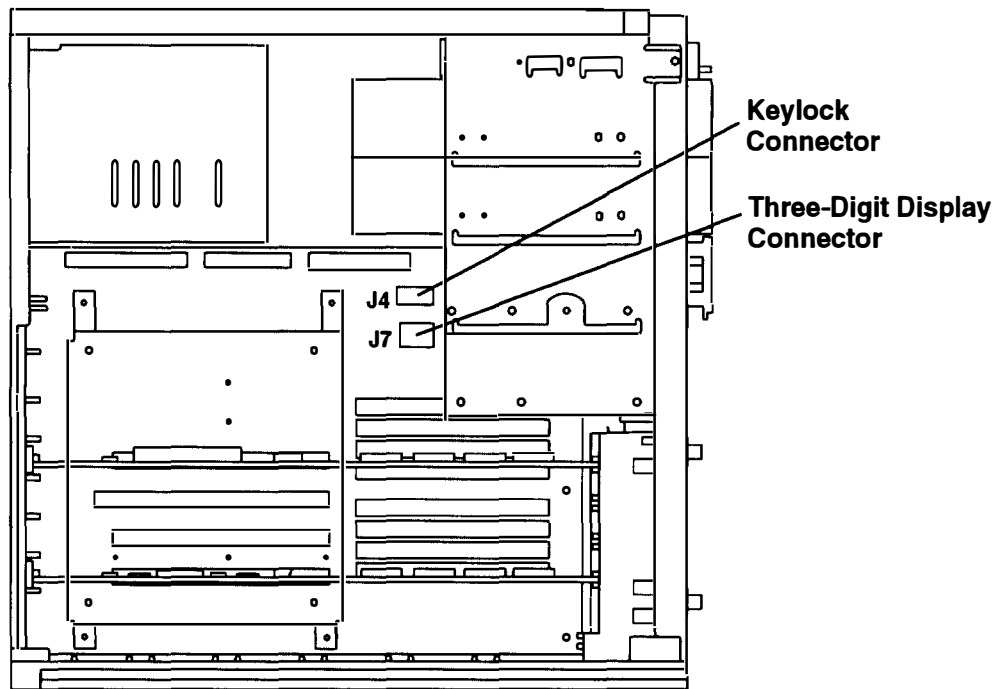

4. Unlatch the left side of the operator panel assembly, then unlatch the right side.

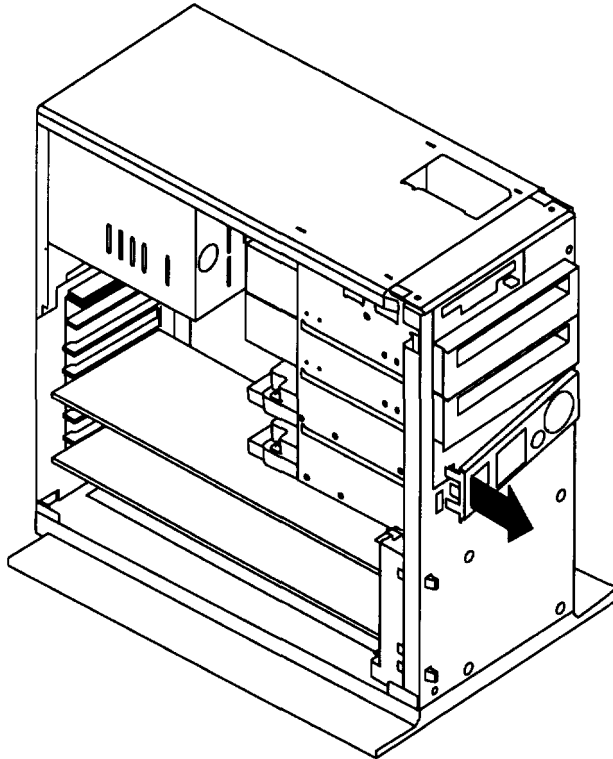

5. Remove the power supply cable from the rear of the operator panel.
6. Remove the fan cable from the rear of the operator panel.

Replacement

To replace the operator panel, do the removal steps in the reverse order.

Fan

Removal

1. Do the removal procedure in "System Unit Cover" on page 3-3.
2. Do the removal procedure in "Adapters" on page 3-27 for all adapters installed in the system unit.
3. Do the removal procedure in "CPU Card" on page 3-34.
4. Remove the card guide from the front of the system unit by pressing inward on the tabs protruding through the front of the system unit chassis, then pulling the card guide backward and out of the system unit.

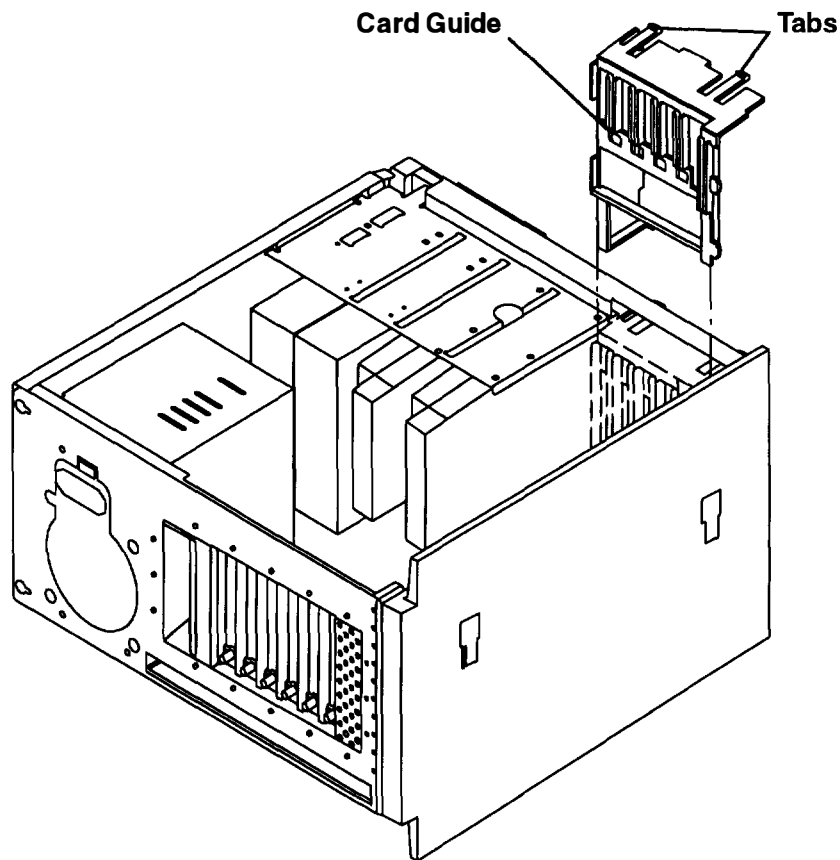

5. Pull the left side of the operator panel assembly out from the front of the chassis, then pull the right side out from the front of the chassis.

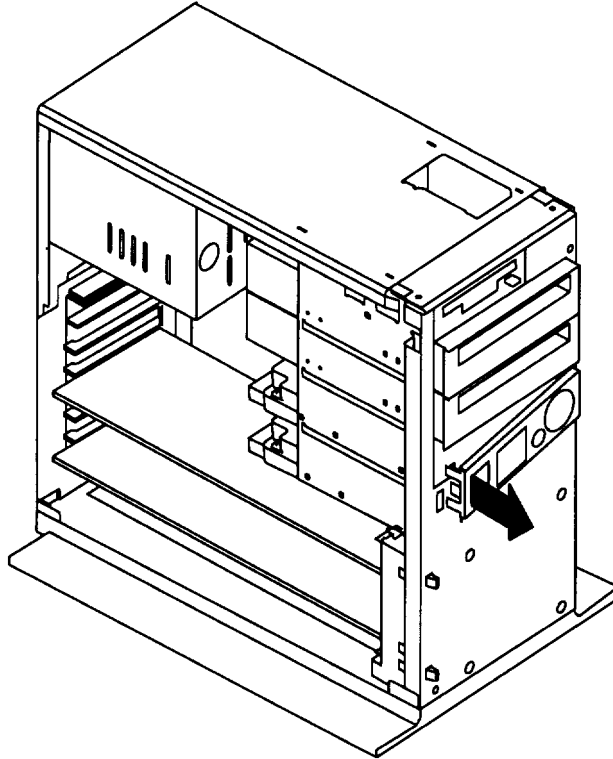

6. Remove the fan cable from the connector on the back of the operator panel.
7. Remove the fan from the system unit. The rubber fasteners should remain attached to the fan.

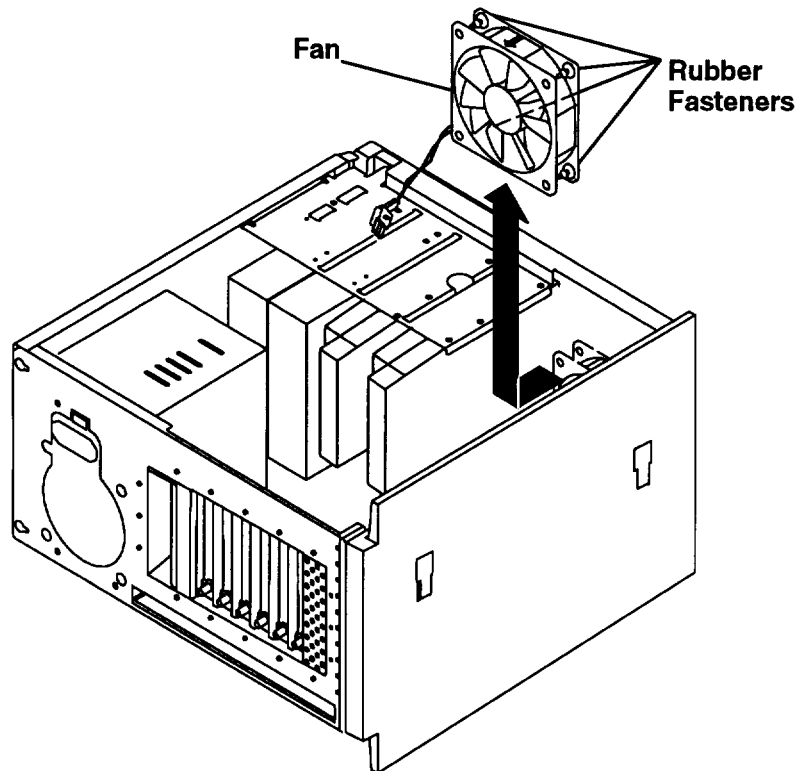

Replacement

To replace the fan, do the removal steps in the reverse order.

Note: Ensure that the airflow (as marked on the fan) is toward the interior of the system unit.

Riser Card

Removal

1. Do the removal procedure in "System Unit Cover" on page 3-3.
2. Do the removal procedure in "Adapters" on page 3-27 for all adapters installed in the system unit.
3. Do the removal procedure in "CPU Card" on page 3-34.
4. The riser card is attached to the riser card bracket by four screws as shown. Remove the screws and lift the riser card from the system planar.

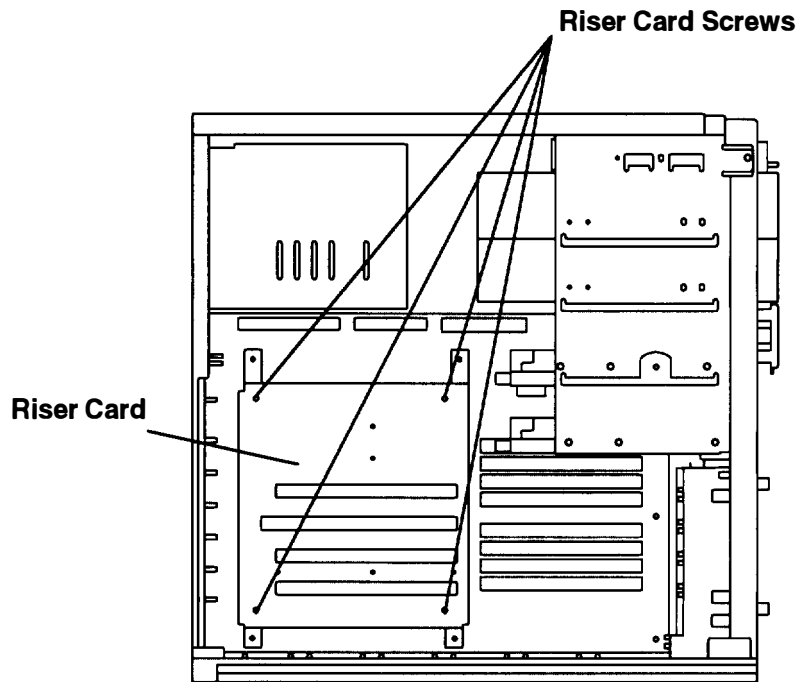

5. Remove the interposer card from the underside of the riser card or from the connector on the system planar.

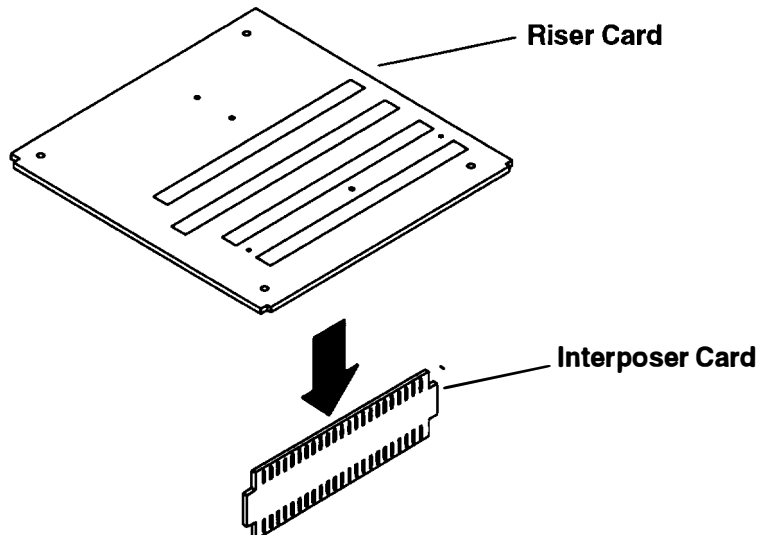

Replacement

1. Insert the interposer card into the connector on the system planar.

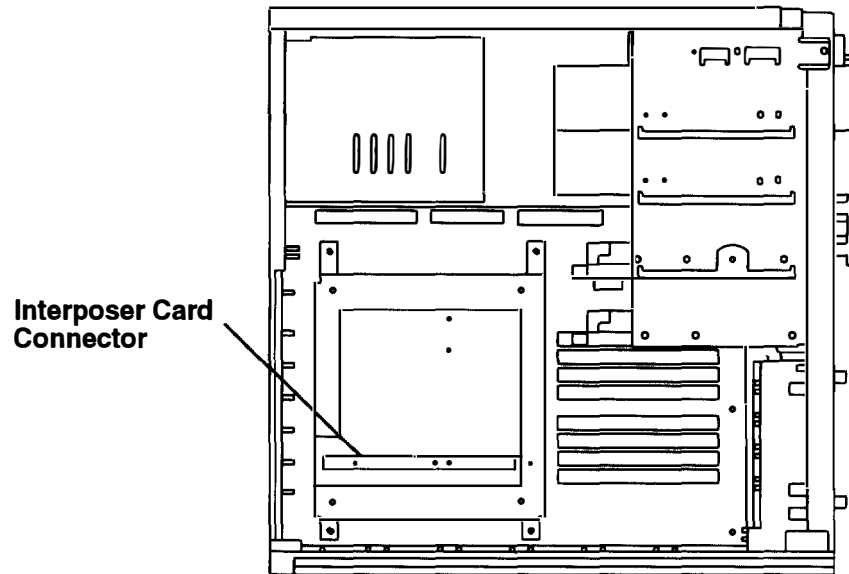

2. Connect the riser card to the interposer card.
3. Insert the four riser card screws, then tighten them.

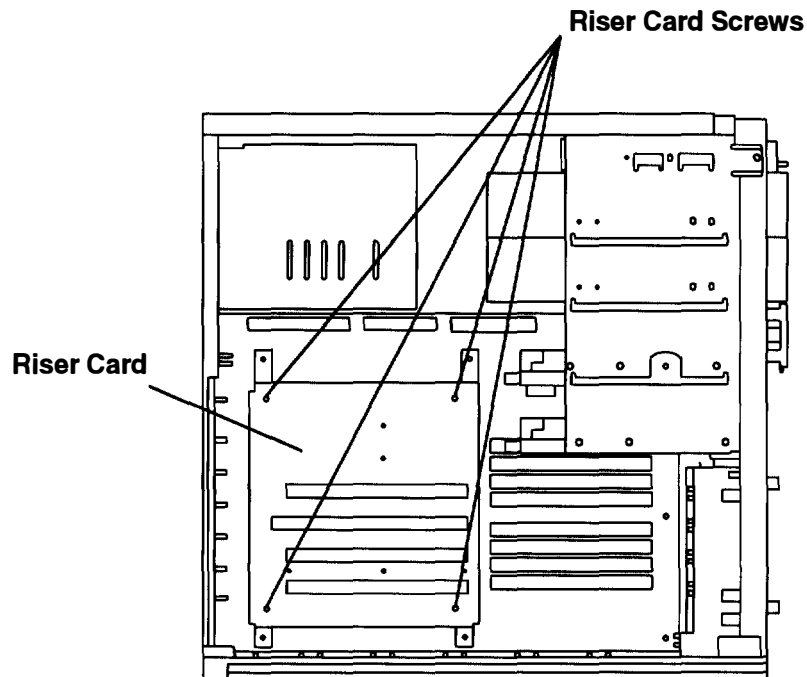

4. Do the replacement procedure in "CPU Card" on page 3-34.
5. Do the replacement procedure in "Adapters" on page 3-27.
6. Do the replacement procedure in "System Unit Cover" on page 3-3.

System Planar

Removal

1. Do the removal procedure in "System Unit Cover" on page 3-3.
2. Remove all cables and terminators attached to the rear of the system unit.
3. Do the removal procedure in "Disk Drive" on page 3-13 for all disk drives installed in the system unit.
4. Do the removal procedure in "Adapters" on page 3-27 for all adapters installed in the system unit.
5. Do the removal procedure in "Memory" on page 3-29.
6. Do the removal procedure in "CPU Feature Card" on page 3-33 if a CPU feature card is installed.
7. Do the removal procedure in "CPU Card" on page 3-34.
8. Remove the card guide from the front of the system unit by pressing inward on the tabs protruding through the front of the system unit chassis, then pulling the card guide backward and out of the system unit.

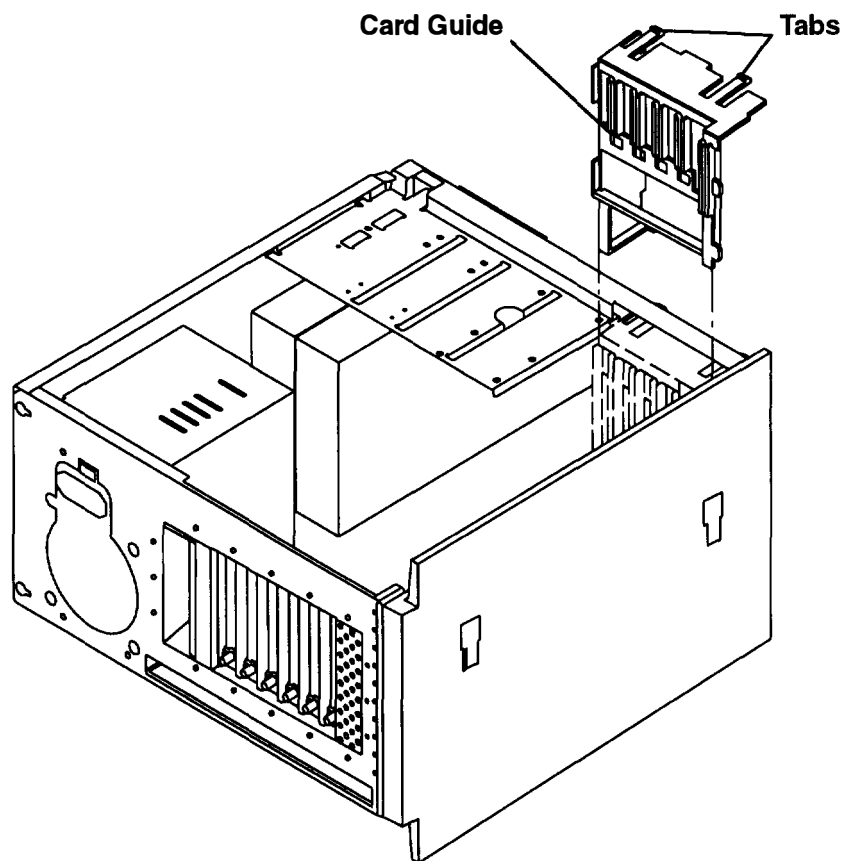

9. Remove these cables in the following order from the connectors on the system planar:

- J7, the three-digit display cable
- J4, the keylock cable
- J3, the system planar power supply
- J2, the diskette cable
- J1, the internal SCSI cable.

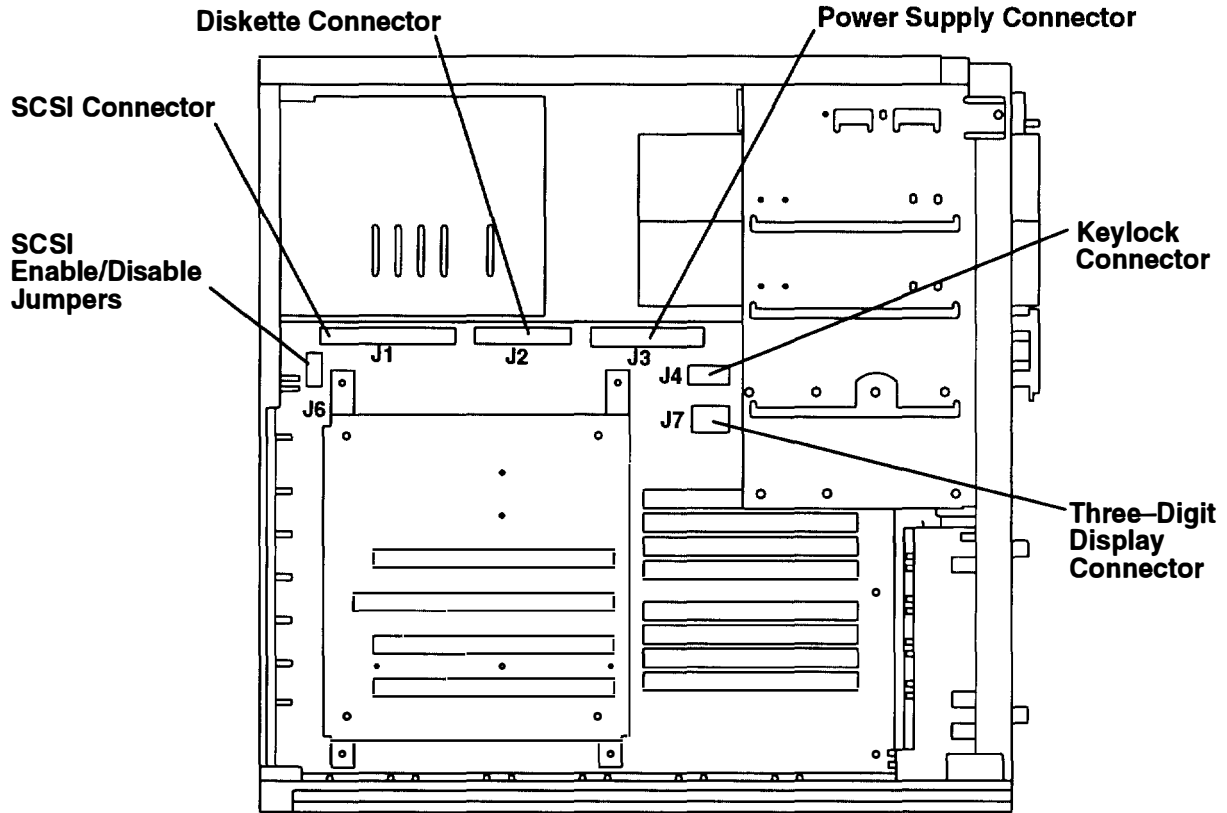

10. Note the setting of the SCSI enable/disable jumpers (J6) on the system planar.

11. To remove the system planar screws:
 - a. Remove screws 1, 2, 5, and 6. Lift the riser card assembly from the system planar.
 - b. Remove screws 3, 4, and 7. To remove screw 3, you must insert the screwdriver through the hole in the upper disk drive position.

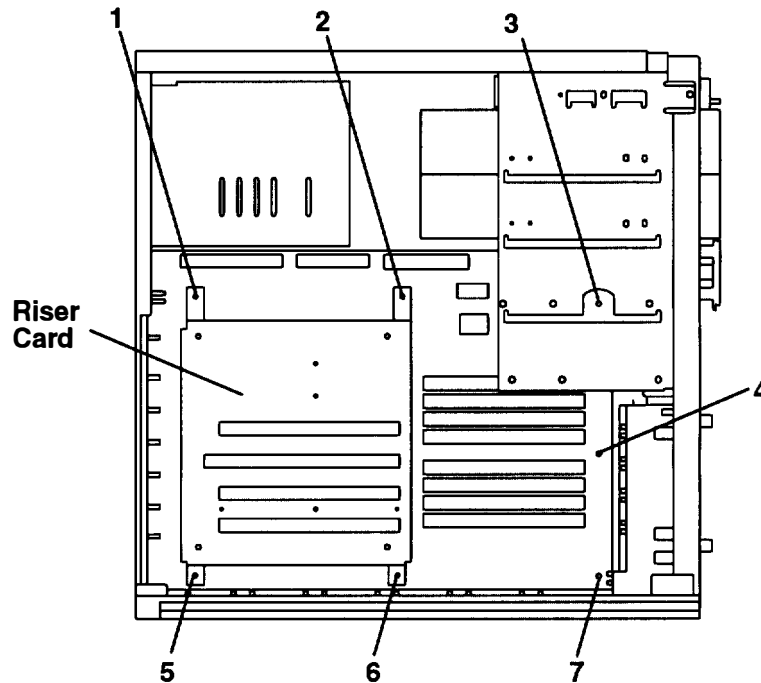

12. Slide the system planar toward the front of the system unit, then tilt the bottom of the system planar outward to remove it from the chassis.

Replacement

1. Set the system planar in the chassis.
2. Do the placement procedure in "Memory" on page 3-29 for all SIMMs removed from the old system planar.
3. Set the SCSI jumpers to the same position as the removed system planar. Refer to "Disable/Enable the SCSI Connector" on page 1-4.
4. Move the system planar toward the rear of the chassis, ensuring that the keyboard, mouse, tablet, serial, parallel, and SCSI connectors slide into the hole in the rear of the chassis.

5. Insert screw 4 but do not tighten completely.

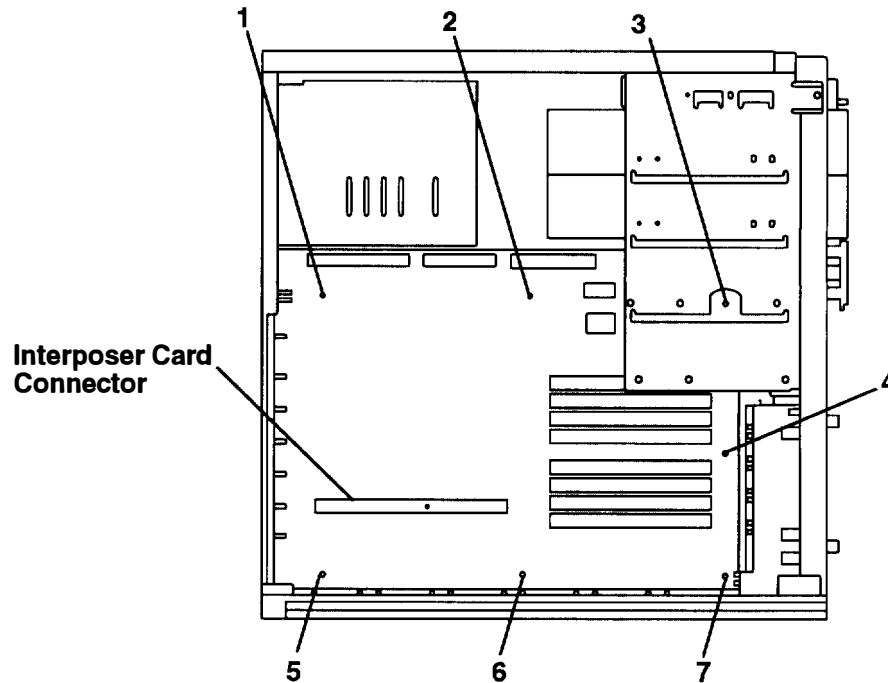

6. Insert the interposer card into the connector on the system planar, then connect the riser card to the system planar. Ensure that the interposer card is fully inserted into the connector on the underside of the riser card.

7. Insert screw 5 but do not tighten completely.

8. Insert screws 1, 2, 3, 6, and 7. Tighten all seven screws.

9. Replace the card guide.

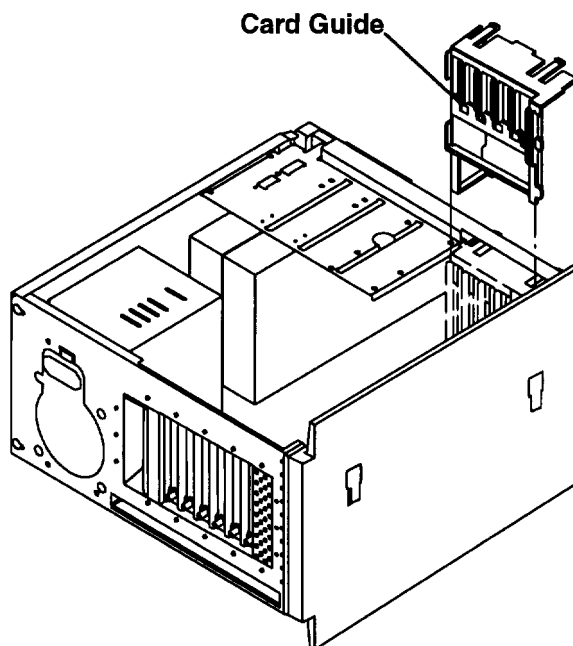

10. Attach these cables in the following order to the connectors on the system planar:

- J1, the internal SCSI cable
- J2, the diskette cable
- J3, the system planar power supply
- J4, the keylock cable
- J7, the three-digit display cable.

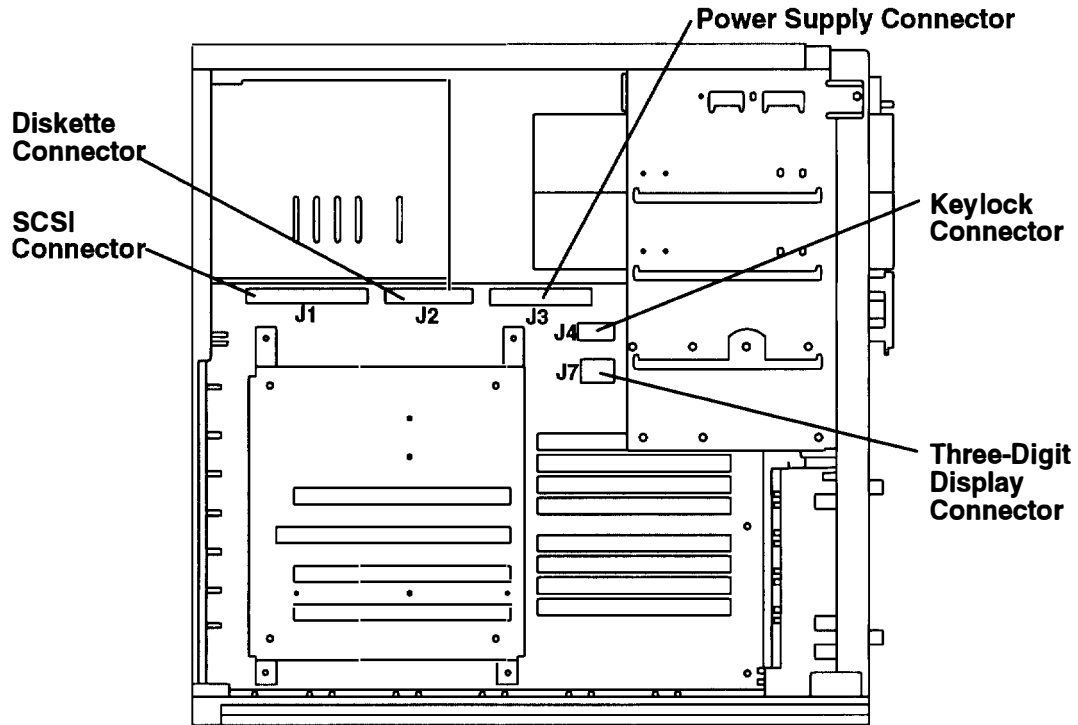

11. Do the replacement procedure in "CPU Card" on page 3-34.

12. Do the replacement procedure in "CPU Feature Card" on page 3-33 if a CPU feature card was removed.

13. If any optional adapters were removed, do the replacement procedure in "Adapters" on page 3-27.

14. Do the replacement procedure in "Disk Drive" on page 3-14 for all disk drives removed from the system unit.

15. Connect all cables and terminators removed from the rear of the system unit.

16. Do the replacement procedure in "System Unit Cover" on page 3-3.

Battery

Note: For a translation of the safety notices, refer to the *System Unit Safety Information*, Order Number SA23-2652.

CAUTION:

A lithium battery can cause fire, explosion, or a severe burn. Do not recharge, disassemble, heat above 100°C (212°F), solder directly to the cell, incinerate, or expose cell contents to water. Keep away from children. Replace only with the part number specified for your system. Use of another battery may present a risk of fire or explosion.

The battery connector is polarized; do not attempt to reverse the polarity.

Dispose of the battery according to local regulations.

When replacing the battery, use Part Number 33F8354 or equivalent.

Removal

1. Do the removal procedure in "System Unit Cover" on page 3-3.

Note: It is not necessary to remove the airflow baffle in order to replace the battery.

2. Press down on the edge of the battery, then lift the battery out of the holder.

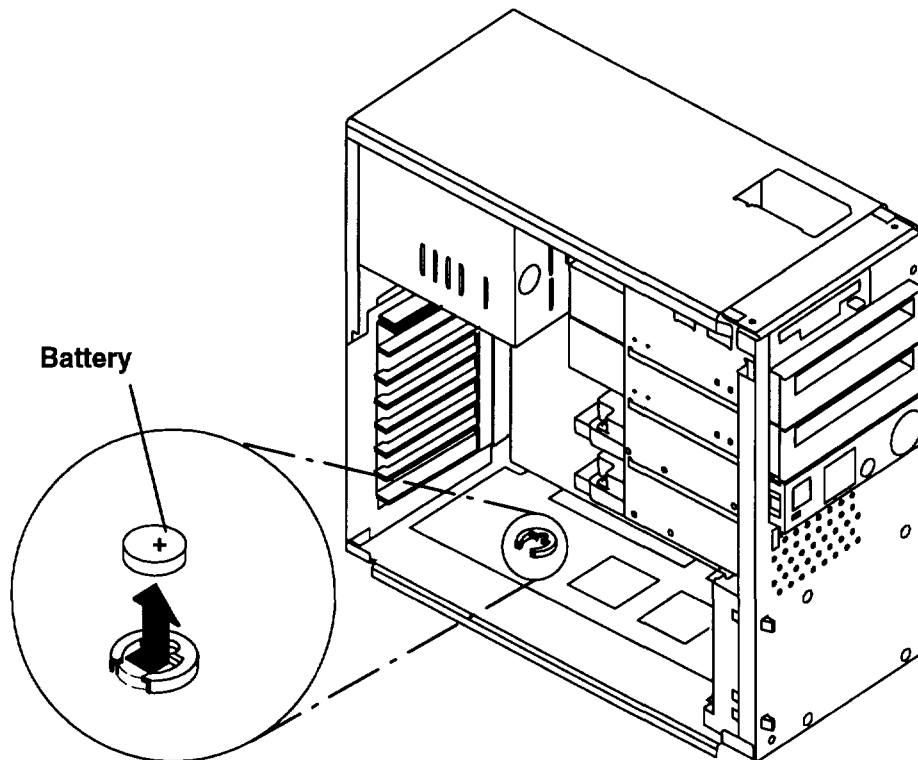

Replacement

1. Install the battery in the holder while being careful to observe correct polarity (positive side up).
2. Do the replacement procedure in “System Unit Cover” on page 3-3.
3. Reset the time and date on your system.

Chapter 4. Diagnostics

Diagnostics

The built-in diagnostics complement the basic troubleshooting techniques featured in "Chapter 2. Maintenance Analysis Procedures (MAPS)."

1. Set the system unit power switch to the Off position if it is not already off.
2. Set the key mode switch to the Secure position.
3. Turn on all attached devices, such as terminals, tape drives, monitors, and external disk drives.
4. Open the operator panel door.
5. Set the system unit power switch to the On position.
6. Wait for 200 to appear in the three-digit display, then continue with step 7.
7. Set the key mode switch to the Service position.
8. Press the Reset button within five seconds. After a minute, the Main Menu should appear.

Main Menu

1. Select BOOT (Startup) Device
2. Select Language for these Menus
3. Send Test Transmission (PING)
4. Show Hardware Configuration
5. Perform Built-In Diagnostics
6. Exit Main Menu and Start System (BOOT)

Type the number for your selection, then press "ENTER"
(Use the "Backspace" key to correct errors)

9. Select the Perform Built-In Diagnostics option (5) from the Main Menu. The Diagnostics screen should be displayed.

Built-in Diagnostics

1. Perform Built-In BASIC Diagnostics
Use this selection for system check-out and problem determination. Service equipment (such as wrap plugs) is not needed
2. Perform Built-In ADVANCED Diagnostics
This selection is normally used by Service personnel. Service equipment (such as wrap plugs) is needed.

NOTE: In addition to your Built-In Diagnostics, diagnostic programs may be provided along with your operating system. Refer to your operating system's diagnostic documentation for instructions on how to use these diagnostic programs.

99. Return to Main Menu

Type the number for your selection, then press "ENTER"
(Use the "Backspace" key to correct errors)

10. Select the Perform Built-In Advanced Diagnostics (option 2) from the Diagnostics menu. The Perform Built-In Advanced Diagnostics Test Selection Menu should be displayed.

Perform Built-In Advanced Diagnostics
Test Selection Menu

NOTE: An * in front of the selection indicates that the test has been run.

1. Run ALL built-in ADVANCED diagnostic tests

LOCATION	TEST DESCRIPTION
2.	Memory
3. 00-00-S1	Serial port
4. 00-00-S2	Serial port
5. 00-00-0P	Parallel port
7. 00-00-0T	Tablet port
8. 00-00-0K	Keyboard port

Page 1 of 3

88. Next Page of Test Selection Menu

99. Return to Main Menu

Type the number for your selection, then press "ENTER"
(Use the "Backspace" key to correct errors)

11. Select the Advanced diagnostic test that you want to run.

Note: The tests that are available depend on the options installed in the system unit.

PERFORM BUILT-IN ADVANCED DIAGNOSTICS

Test Selection Menu

NOTE: An * in front of the selection indicates that the test has been run.

LOCATION	TEST DESCRIPTION
9. 00-00-0D	Diskette port
10. 00-00-0S	SCSI port
11. 00-00-0K	Keyboard-101 keys
12. 00-00-05-00	1GB SCSI Disk Drive
13. 00-00-0D	3.5 Inch 2.88 MB Diskette Drive

Page 2 of 3

88. Next Page of Test Selection Menu

77. Previous Test Selection Menu

99. Return to Main Menu

Type the number for your selection, then press "ENTER"
(Use the "Backspace" key to correct errors)

PERFORM BUILT-IN ADVANCED DIAGNOSTICS

Test Selection Menu

NOTE: An * in front of the selection indicates that the test has been run.

LOCATION	TEST DESCRIPTION
14. 00-01	Token-Ring High-Performance Network Adapter

Page 3 of 3

77. Previous Test Selection Menu

99. Return to Main Menu

Type the number for your selection, then press "ENTER"
(Use the "Backspace" key to correct errors)

Chapter 5. Parts Information

Chassis, Power Supply, and Internal Devices

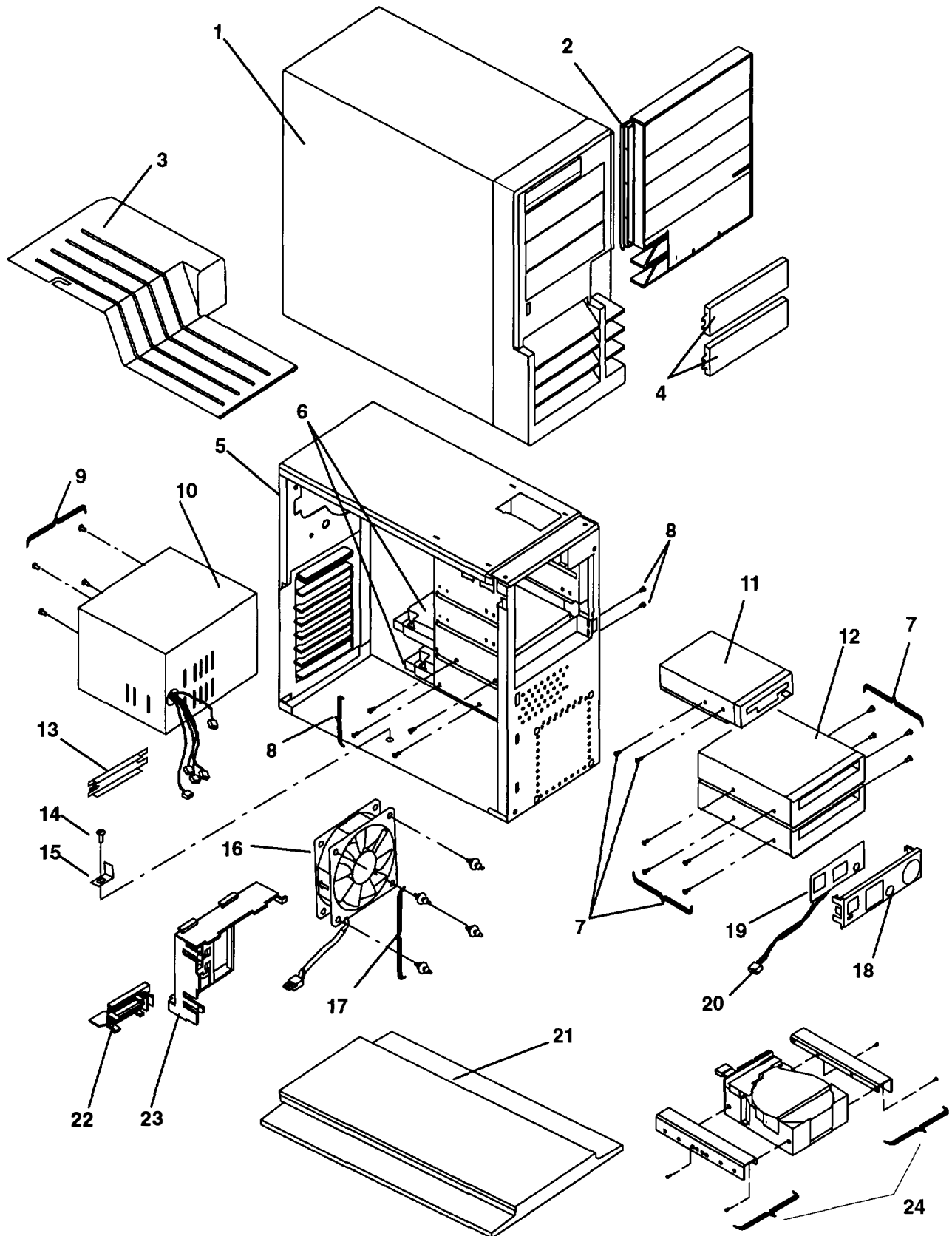

Index Number	Part Number	Units Per Asm	Description
1	65G7972	1	Cover Assembly
2	11H8612	1	Cover Hinge
3	65G7970	1	Airflow Baffle
4	41F0636	2	Cover Plate
5	65G7982	1	Chassis Assembly
6	See Note	Up to 4	Disk Drive
7	33G3907	3 or 6	Diskette and Media Device Mounting Screws
8	1147429	4 or 8	Disk Drive Mounting Screws
9	8185165	4	Power Supply Mounting Screws
10	09G3802	1	Power Supply
	11H8609	1	Power Supply with Longer Cable
11	52G3400	1	Diskette Drive
12	See Note	1	Media Drive
13	6279235	6	EMI Shield
14	8185165	1	CPU Card Bracket Screw
15	65G8101	1	CPU Card Bracket
16	65G7989	1	120mm Cooling Fan
17	81F7977	4	Fan Mounting Grommets
18	65G7994	1	Operator Panel Assembly
	65G8290	1	Operator Panel Assembly with Keyless Lock
19	65G8005	1	Operator Panel Card Assembly
20	65G8008	1	Operator Panel Cable
21	06H3486	1	System Unit Pedestal
22	40F9969	4	Type 3 Adapter Fastener
23	65G7988	1	Adapter Guide
24	65G8299	1 or 2	Disk Drive Mounting Kit for Media Drive Position
Note: See the <i>Adapters, Devices, and Cable Information</i> , SA23-2764.			

System Planar, CPU Card, and Internal Cables

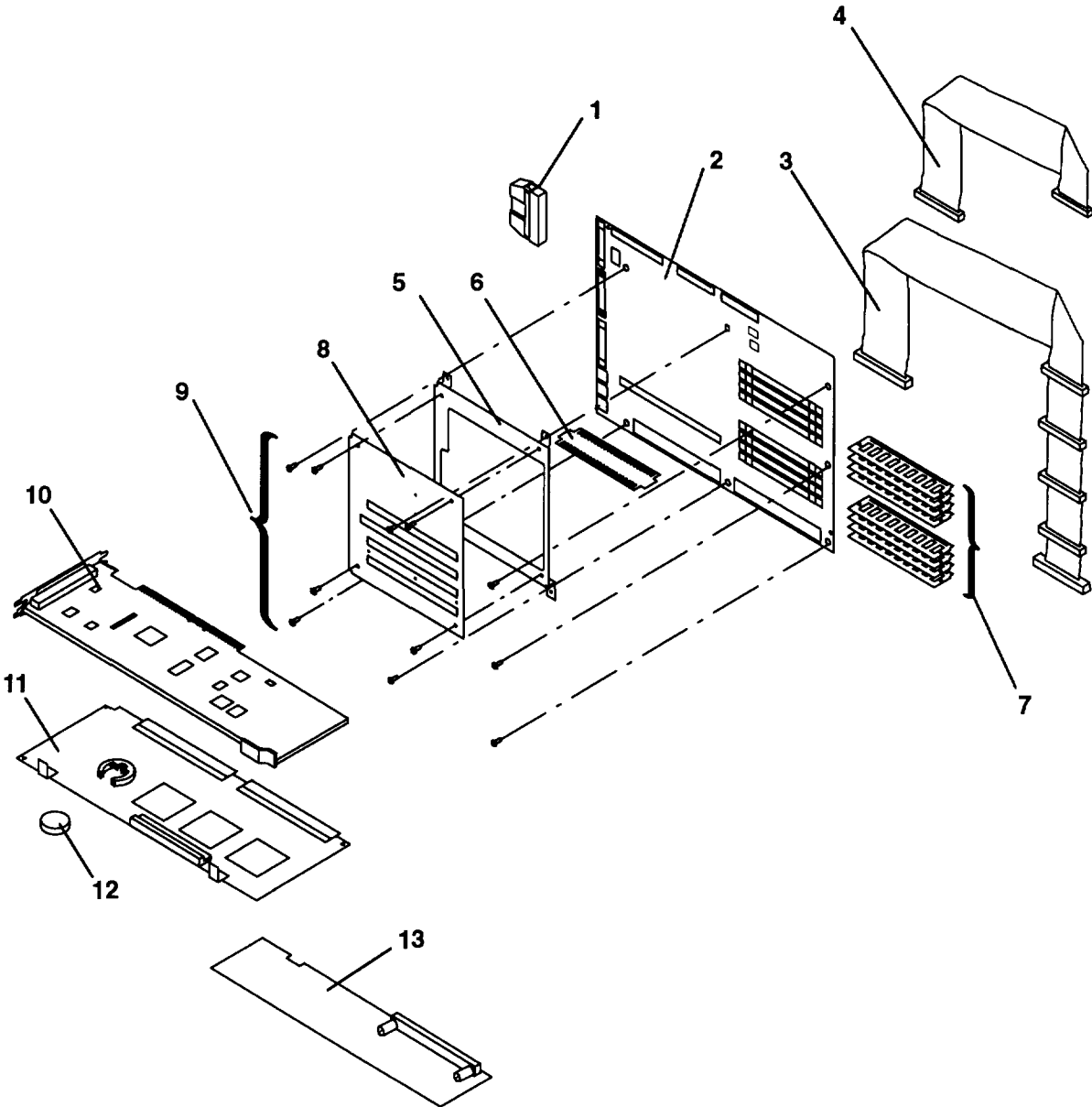

Index Number	Part Number	Units Per Asm	Description
1	51G7737	1	System Unit SCSI Terminator
2	65G7904	1	System Planar
3	65G8006	1	Internal SCSI Cable with Terminator
4	65G8007	1	Diskette Cable
5	65G7999	1	Riser Card Bracket
6	65G7949	1	Interposer Card
7	92F0102	4 or 8	2 MB SIMM
	51G8553	4 or 8	4 MB SIMM
	51G8554	4 or 8	8 MB SIMM
	60G2950	4 or 8	16 MB SIMM
	73G3235	4 or 8	32 MB SIMM
8	65G7942	1	Riser Card
9	8185165	11	System Planar Mounting Screws
10	See Note	up to 4	Optional Adapter
11	65G8331	1	CPU Card: PowerPC 601™ processor
	65G8126	1	CPU Card: PowerPC 604™ processor
12	33F8354	1	Battery
13	65G7929	1	Level-2 Cache Card
Note: See the <i>Adapters, Devices, and Cable Information, SA23–2764.</i>			

Keyboard, Mouse, and Serial Dual-Port Cable

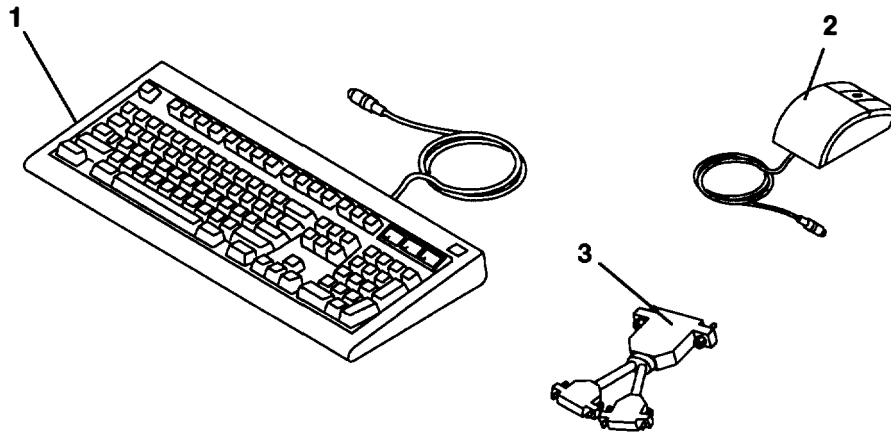

Index Number	Part Number	Units Per Asm	Description
1	1394540	1	Keyboard, United States English
	1394541	1	Keyboard, French Canadian
	1394542	1	Keyboard, German
	1394544	1	Keyboard, Danish
	1394543	1	Keyboard, Belgian-French/Dutch
	1394545	1	Keyboard, Finnish/Swedish
	1394546	1	Keyboard, French
	1394547	1	Keyboard, Italian
	1394548	1	Keyboard, Norwegian
	1394549	1	Keyboard, Portuguese
	1394550	1	Keyboard, Spanish
	1394551	1	Keyboard, Swiss German/French
	1395968	1	Keyboard, Icelandic
	1395984	1	Keyboard, CSA166
	1395985	1	Keyboard, United Kingdom English
	1396077	1	Keyboard, Turkish
	1396078	1	Keyboard, Greek
	1396079	1	Keyboard, Arabic
	1396080	1	Keyboard, Hebrew
	30F9388	1	Keyboard, Kanji
	10G8753	1	Keyboard, Taiwan-Chinese
	10G8752	1	Keyboard, Korean
	0432778	1	Keyboard, Dutch
	0432775	1	Keyboard, Turkish
2	51G9652	1	Mouse, 3-button
3	31F4590	1	Serial Dual-Port Cable

Power Cables and Plugs

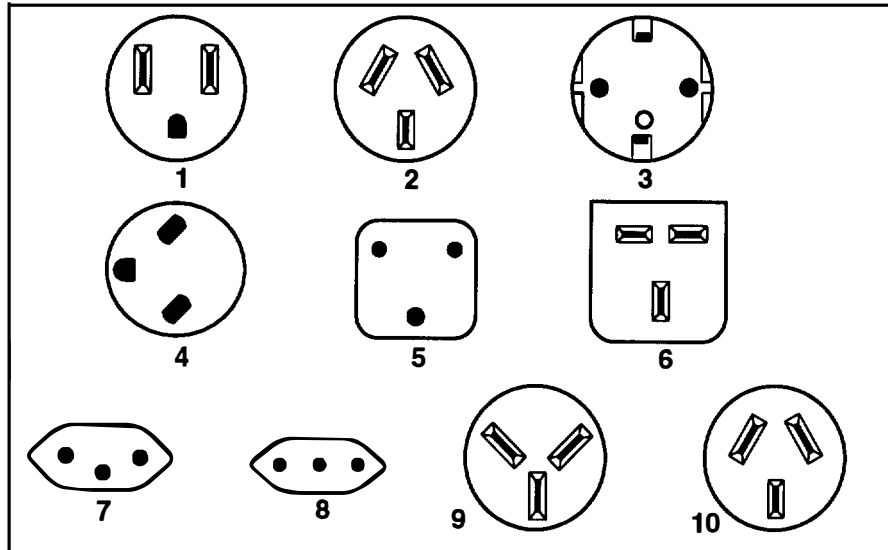

Part Number	Country	Index
62X0663	Bahamas, Barbados, Bermuda, Bolivia, Brazil, Canada, Cayman Islands, Colombia, Costa Rica, Dominican Republic, Ecuador, El Salvador, Guatemala, Guyana, Haiti, Honduras, Jamaica, Japan, Korea (South), Mexico, Netherlands Antilles, Nicaragua, Panama, Peru, Philippines, Puerto Rico, Saudi Arabia, Suriname, Trinidad, Taiwan, U.S.A., Venezuela	1
13F9940	Argentina, Australia, New Zealand,	2
13F9979	Abu Dhabi, Austria, Belgium, Bulgaria, Botswana, Egypt, Finland, France, Germany, Greece, Iceland, Indonesia, Korea (South), Lebanon, Luxembourg, Macau, Netherlands, Norway, Portugal, Saudi Arabia, Spain, Sudan, Sweden, Turkey, Yugoslavia	3
13F9997	Denmark	4
14F0015	Bangladesh, Burma, Pakistan, South Africa, Sri Lanka	5
14F0033	Bahrain, Bermuda, Brunei, Channel Islands, Cyprus, Ghana, Hong Kong, India, Iraq, Ireland, Jordan, Kenya, Kuwait, Malawi, Malaysia, Nigeria, Oman, People's Republic of China, Qatar, Sierra Leone, Singapore, Tanzania, Uganda, United Arab Emirates (Dubai), United Kingdom, Zambia	6
14F0051	Liechtenstein, Switzerland	7
14F0069	Chile, Ethiopia, Italy	8
14F0087	Israel	9
13F9939	Paraguay, Colombia, Uruguay	10

Index

A

adapter, Fast/Wide SCSI, 3-21
adapters, 3-27
 Fast/Wide SCSI, 3-28
 location, 1-2
 removal, 3-27
 replacement, 3-28
 Type 3 fastener, 3-28
airflow baffle
 removal, 3-5
 replacement, 3-6
airflow direction, 3-40

B

battery, 3-48
 removal, 3-48
 replacement, 3-49

C

cables, power, 1-6
clock, need to reset, 3-35
cover, 3-3
 removal, 3-3
 replacement, 3-6
CPU card, 3-34
 location, 1-2
 removal, 3-34
 replacement, 3-35
CPU feature card, 3-33
 removal, 3-33
 replacement, 3-33

D

diagnostics, 4-1
disable the SCSI connector, 1-4
disk drive, 3-16
 removal, 3-16
 replacement, 3-18
disk drives, location, 1-2

diskette drive, 3-11
 location, 1-2
 removal, 3-11
 replacement, 3-12

E

enable the SCSI connector, 1-4

F

fan, 3-38
 location, 1-2
 removal, 3-38
 replacement, 3-40
Fast/Wide SCSI cable
 removal, 3-4
 replacement, 3-6
Fast/Wide SCSI cable, attachment, 3-21
feature card, CPU, 3-33

H

handle, 1-2
handling static-sensitive devices, 3-1

I

interposer card
 removal, 3-41
 replacement, 3-42

K

key mode switch, location, 1-1

M

MAP 1520: power map, 2-1520-1
MAP 1540: minimum machine configuration,
 2-1540-1

MAP 1560: diagnostics, 2-1560-1

media drive, 3-13
location, 1-2
removal, 3-13
replacement, 3-14

memory, 3-29
removal, 3-29
replacement, 3-31
requirements, 3-31

O

operator panel, 3-36
location, 1-1, 1-2
removal, 3-36
replacement, 3-37

P

parts information, 5-1
power cables, 1-6
power map, MAP 1520, 2-1520-1
power supply, 3-8
cables, 3-22
location, 1-2
removal, 3-8
replacement, 3-10
power switch, location, 1-1

R

reset button, location, 1-1
riser card, 3-41
removal, 3-41
replacement, 3-42

S

screw starter, 3-23

SCSI cable
Fast/Wide, 3-21
removal, 3-4
replacement, 3-6
internal, 3-21, 3-25
removal, 3-25
replacement, 3-26

SCSI connector
disable/enable, 1-4
termination, 3-24

serial number, location, 1-1
service inspection guide, 1-7

SIMMs, 3-29
removal, 3-29
replacement, 3-31

specifications, system unit, 1-5

system planar, 3-43
location, 1-2
removal, 3-43
replacement, 3-45

system planar locations, 1-3

system unit
specifications, 1-5
unique identification number, 3-35

system unit locations
front view with cover, 1-1
front view with door open, 1-1
front view without cover, 1-2
rear view, 1-2

T

three-digit display, 3-36
location, 1-1
three-digit display
removal, 3-36
replacement, 3-37

U

unique identification number, 3-35

Printed in the U.S.A.

11 H8628



SA23-2716-01

