

7010 Xstation Model 140

Setup, Operators, and Service Guide





7010 Xstation Model 140

Setup, Operators, and Service Guide

First Edition (October 1993)

This edition notice applies to the *7010 Xstation Model 140 Setup, Operator, and Service Guide*.

The following paragraph does not apply to the United Kingdom or any country where such provisions are inconsistent with local law: THIS PUBLICATION IS PRINTED "AS IS" WITHOUT WARRANTY OF ANY KIND, EITHER EXPRESS OR IMPLIED, INCLUDING, BUT NOT LIMITED TO, THE IMPLIED WARRANTIES OF MERCHANTABILITY OR FITNESS FOR A PARTICULAR PURPOSE. Some states do not allow disclaimer of express or implied warranties in certain transactions; therefore, this statement may not apply to you.

This publication could include technical inaccuracies or typographical errors. Changes are periodically made to the information herein; these changes will be incorporated in new editions of the publication.

It is possible that this publication may contain reference to, or information about, products (machines and programs), programming, or services that are not announced in your country. Such references or information must not be construed to mean that such products, programming, or services will be offered in your country. Any reference to a licensed program in this publication is not intended to state or imply that you can use only the licensed program. You can use any functionally equivalent program instead.

Xstation Manager is a trademark of International Business Machines Corporation.

©Copyright International Business Machines Corporation, 1993. All rights reserved.

Note to U.S. Government Users – Documentation and programs related to restricted rights – Use, duplication, or disclosure is subject to the restrictions set forth in GSA ADP Schedule Contract

Table of Contents

Communications Statements	vii
Federal Communications Commission (FCC) Statement	vii
VCCI Statement	vii
Avis de conformité aux normes du ministère des Communications du Canada	viii
Canadian Department of Communications Compliance Statement	viii
United Kingdom Telecommunications Safety Requirements	viii
International Electrotechnical Commission (IEC) Statement	viii
Safety Notices	ix
About This Book	xi
Part 1. Setup and Operation	
Chapter 1. Hardware Setup	1-1
Step 1. Inventory	1-1
Step 2. Install Optional Features	1-2
Step 3. Connect the Cables	1-3
Step 4. Position the Xstation	1-10
Chapter 2. Optional Features Installation	2-1
Handling Static-Sensitive Devices	2-2
Remove the Chassis Assembly	2-3
Options Checklist	2-4
Install Optional SIMMs	2-5
Install Optional FLASH Card	2-7
Configure Ethernet	2-8
Configure System Jumpers	2-10
Display Jumpers	2-10
Password-Reset Jumper	2-12
Recover Boot Jumper	2-12
Alternate Boot Jumper	2-13
Speaker Jumper	2-13
Replace the Chassis Assembly	2-14
Install an Optional Serial Port Fan Out Cable	2-15
Chapter 3. Xstation Configuration and Startup	3-1
Step 1. Start the Xstation	3-1
Step 2. Select a Language	3-2
Xstation Session	3-2
Configuration	3-3
Utilities	3-3

Step 3. Establish Network Connection	3-5
Example 1. Using Broadcast BOOTP on a LAN without Gateways or Bridges	3-7
Example 2. Using Direct BOOTP on a LAN that has Gateways or Bridges	3-8
Example 3. Disabling BOOTP and Enabling the Direct XDMCP Mode	3-10
Example 4. Configuring a Network Connection for a Non-AIX Environment	3-12
Remote Configuration	3-13
Example 5. Updating FLASH from the Network	3-14
Step 4. Choose Terminal Mode	3-15
X-Windows Mode	3-15
Telnet Terminal Mode	3-15
Asynchronous Terminal Mode	3-16
Chapter 4. Keyboard and Mouse Operation	4-1
Using the Keyboard	4-1
Using the Mouse	4-2
Handling the Mouse Correctly	4-3
Care of the Mouse	4-3
Cleaning the Mouse	4-4
Chapter 5. Problem Determination Procedures	5-1
Error Analysis	5-2
LAN Error Analysis	5-4
Recommended Action	5-5
Part 2. Service	
Chapter 6. Reference Information	6-1
Xstation Locations	6-1
Front View with Cover	6-1
Side View with Cover	6-1
Rear View with Cover	6-2
System Board	6-2
Maintenance Package	6-3
Tools	6-3
Specifications	6-3
Service Inspection Guide	6-5
Service Inspection Checklist	6-5
Chapter 7. MAPs	7-0000-1
Start of Call	7-0000-1
MAP 0010: Start Maps	7-0010-1
MAP 0020: Power	7-0020-1
MAP 0030: Displays	7-0030-1
MAP 0040: Diagnostics	7-0040-1

Chapter 8. Removal and Replacement Procedures	8-1
Introduction	8-1
Electrical Safety	8-1
Handling Static-Sensitive Devices	8-2
Chassis Assembly	8-3
Power Supply	8-6
System Board	8-7
Fan	8-9
Cover Assembly	8-10
Chapter 9. Parts Information	9-1
Appendix A. Moving the Xstation	A-1
Appendix B. Securing the Xstation	B-1
Index	X-1

Communications Statements

The following communications statements apply to this product. The communications statements for other products intended for use with this product appears in their accompanying manuals.

Federal Communications Commission (FCC) Statement

Note: This equipment has been tested and found to comply with the limits for a Class A digital device, pursuant to Part 15 of the FCC Rules. These limits are designed to provide reasonable protection against harmful interference when the equipment is operated in a commercial environment. This equipment generates, uses, and can radiate radio frequency energy and, if not installed and used in accordance with the instruction manual, may cause harmful interference to radio communications. Operation of this equipment in a residential area is likely to cause interference in which case users will be required to correct the interference at their own expense.

Properly shielded and grounded cables and connectors must be used in order to meet FCC emission limits. Neither the provider nor the manufacturer of this product are responsible for any radio or television interference caused by using other than recommended cables and connectors or by unauthorized changes or modifications to this equipment. Unauthorized changes or modifications could void the user's authority to operate the equipment.

This device complies with Part 15 of the FCC Rules. Operation is subject to the following two conditions: (1) this device may not cause harmful interference, and (2) this device must accept any interference received, including interference that may cause undesired operation.

電波障害自主規制 届出装置の記述

この装置は、第一種情報装置（商工業地域において使用されるべき情報装置）で商工業地域での電波障害防止を目的とした情報処理装置等電波障害自主規制協議会（VCCI）基準に適合しております。

従って、住宅地域またはその隣接した地域で使用すると、ラジオ、テレビジョン受信機等に受信障害を与えることがあります。

取扱説明書に従って正しい取り扱いをしてください。

VCCI Statement

The following is a summary of the VCCI Japanese statement in the box above.

This equipment is Type 1 Data Processing Equipment and is intended for use in commercial and industrial areas. When used in residential areas, or areas of proximity, radio and TV reception may be subject to radio interference. VCCI-1.

Avis de conformité aux normes du ministère des Communications du Canada

Cet équipement ne dépasse pas les limites de Classe A d'émission de bruits radioélectriques pour les appareils numériques, telles que prescrites par le Règlement sur le brouillage radioélectrique établi par le ministère des Communications du Canada. L'exploitation faite en milieu résidentiel peut entraîner le brouillage des réceptions radio et télé, ce qui obligerait le propriétaire ou l'opérateur à prendre les dispositions nécessaires pour en éliminer les causes.

Canadian Department of Communications Compliance Statement

This equipment does not exceed Class A limits for radio noise emissions for digital apparatus, set out in Radio Interference Regulation of the Canadian Department of Communications. Operation in a residential area may cause unacceptable interference to radio and TV reception requiring the owner or operator to take whatever steps necessary to correct the interference.

Radio Protection for Germany

Instructions to User: Properly shielded and grounded cables and connectors must be used for connection to peripherals in order to meet German emission limits. Shielded, grounded cables with inline filters are included with certain peripherals and features. These cables should be used to ensure that the 7010 system will comply with the German limits.

In addition, when attaching peripherals to the parallel printer port, the cable P/N 1525612 with the in-line filter should be used for compliance to the German requirements.

United Kingdom Telecommunications Safety Requirements

This apparatus is approved under approval number NS/G/1234/J/100003 for indirect connection to public telecommunication systems in the United Kingdom.

International Electrotechnical Commission (IEC) Statement

This product has been designed and built to comply with (IEC) Standard 950

Safety Notices

Note: For a translation of these notices, see the *System Unit Safety Information*, Form Number SA23-2652.

Definitions of Safety Notices

A *danger* notice indicates the presence of a hazard that has the potential of causing death or serious personal injury.

Danger notices appear on the following pages:

x
1-3
2-1
8-1
8-6
A-1.

A *caution* notice indicates the presence of a hazard that has the potential of causing moderate or minor personal injury.

Caution notices appear on the following pages:

x
1-3
2-1
8-1
A-1.

A *warning* notice indicates the presence of a hazard that has the potential of causing damage to a program, device, system, or data.

Warning notices appear on the following pages:

1-10
2-2
8-2
A-1.

Electrical Safety

DANGER

An electrical outlet that is not correctly wired could place hazardous voltage on metal parts of the system or the devices that attach to the system. It is the responsibility of the customer to ensure that the outlet is correctly wired and grounded to prevent an electrical shock.

Before installing or removing signal cables, ensure that the power cables for the system unit and all attached devices are unplugged.

When adding or removing any additional devices to or from the system, ensure that the power cables for those devices are unplugged before the signal cables are connected. If possible, disconnect all power cables from the existing system before you add a device.

Use one hand, when possible, to connect or disconnect signal cables to prevent a possible shock from touching two surfaces with different electrical potentials.

During an electrical storm, do not connect cables for display stations, printers, telephones, or station protectors for communications lines.

CAUTION:

This product is equipped with a 3-wire power cable and plug for the user's safety. Use this power cable in conjunction with a properly grounded electrical outlet to avoid electrical shock.

About This Book

How to Use This Book

Part 1 of this book is written for the 7010 Xstation Model 140 user. This part contains information and procedures required to install, operate, and test the Xstation 140.

Part 2 of this book is written for trained service personnel. This part contains maintenance analysis procedures (MAPs) and reference information for the 7010 Xstation Model 140.

Related Publications

The *Xstation Manager/6000 Version 1.4.1 System Management Guide*, Form Number SC23-2264, provides installation, configuration, and maintenance information for Xstations using the Xstation Manager program.

Part 1. Setup and Operation

Chapter 1. Hardware Setup

This chapter contains the steps involved in setting up your hardware.

Step 1. Inventory

1. Unpack the 7010 Xstation Model 140, the display, keyboard, and any other devices. Be sure to check for smaller items such as cables, or memory cards.

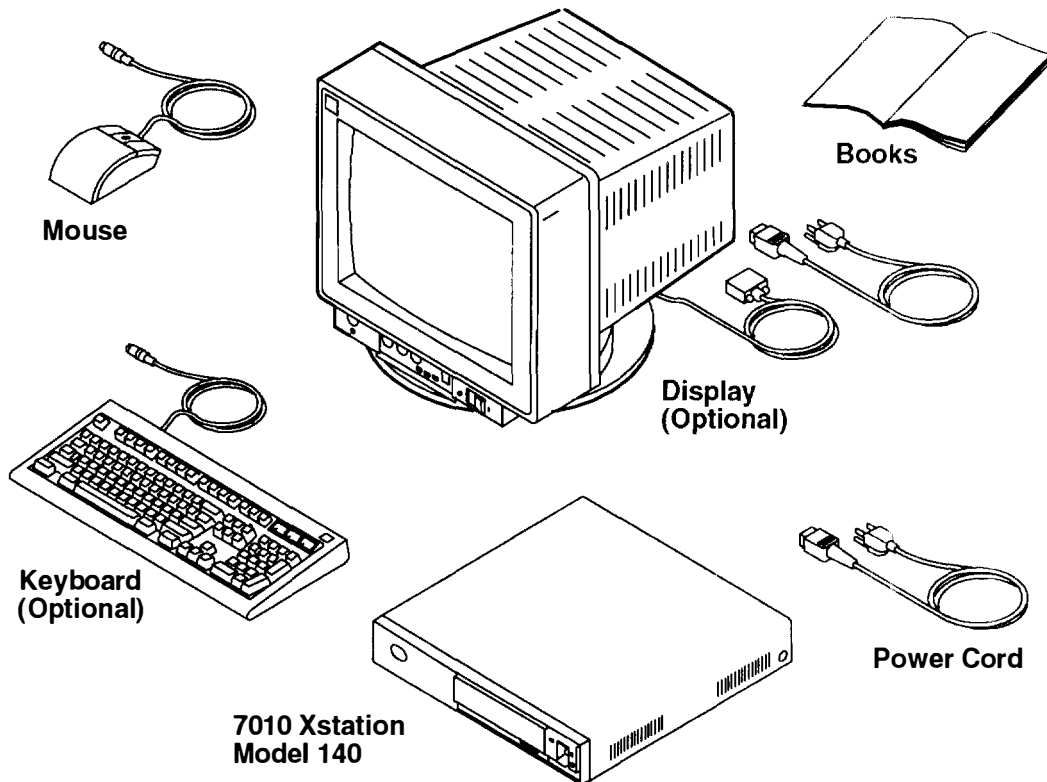

2. Record and retain the following information:

Product Name	7010 Xstation
Model Number	Model 140
Serial Number	

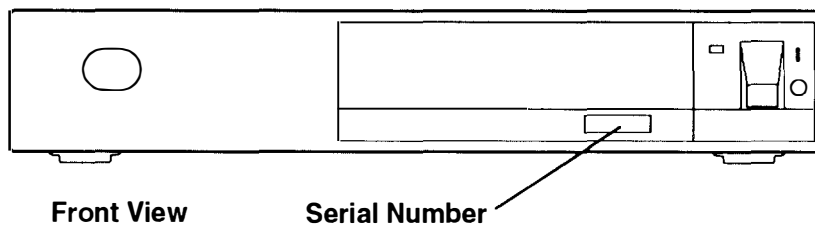

Step 2. Install Optional Features

Check which of the following tasks you want to perform:

- Install Optional SIMMs
- Install Optional FLASH Card
- Configure Ethernet connection to Thick, Thin, or Twisted-Pair
- Configure System Jumpers
- Install Optional Serial Port Fan Out Cable

Notes:

1. You can refer to page 2-10 for a record of the latest display jumper setting. The factory setting for display jumpers is 1 1 1 1.
2. After a new installation, verify that all requested options are installed and that your Xstation is properly configured.

Did you check any of the items in the list?

No Proceed to “Step 3. Connect the Cables” on page 1-3.

Yes If you only checked Install Optional Serial Port Fan Out Cable, go to Chapter 2, “Install an Optional Serial Port Fan Out Cable” on page 2-15.

If you checked any other items in the list, go to the beginning of Chapter 2, “Optional Features Installation.”

Step 3. Connect the Cables

1. Read the following notices:

DANGER

An electrical outlet that is not correctly wired could place hazardous voltage on metal parts of the system or the devices that attach to the system. It is the responsibility of the customer to ensure that the outlet is correctly wired and grounded to prevent an electrical shock.

Before installing or removing signal cables, ensure that the power cables for the system unit and all attached devices are unplugged.

When adding or removing any additional devices to or from the system, ensure that the power cables for those devices are unplugged before the signal cables are connected. If possible, disconnect all power cables from the existing system before you add a device.

Use one hand, when possible, to connect or disconnect signal cables to prevent a possible shock from touching two surfaces with different electrical potentials.

During an electrical storm, do not connect cables for display stations, printers, telephones, or station protectors for communications lines.

CAUTION:

This product is equipped with a 3-wire power cable and plug for the user's safety. Use this power cable in conjunction with a properly grounded electrical outlet to avoid electrical shock.

2. Turn off the Xstation, display, and all devices.

3. Plug the keyboard cable into the keyboard and the other end (flat side up) into the Xstation I/O panel as shown.

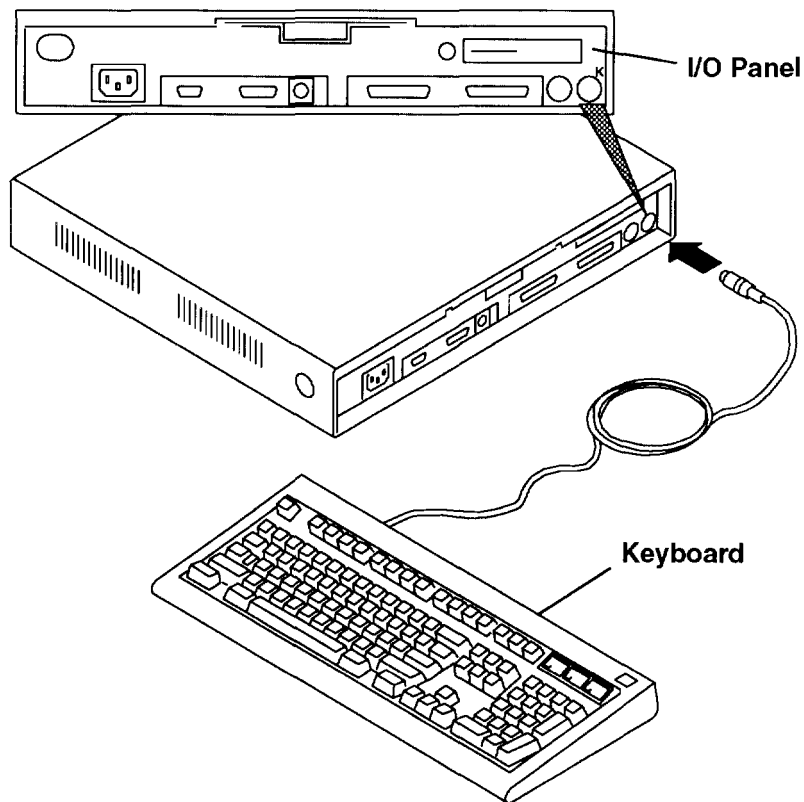

4. Plug the mouse cable (arrow up) into the Xstation I/O panel as shown.

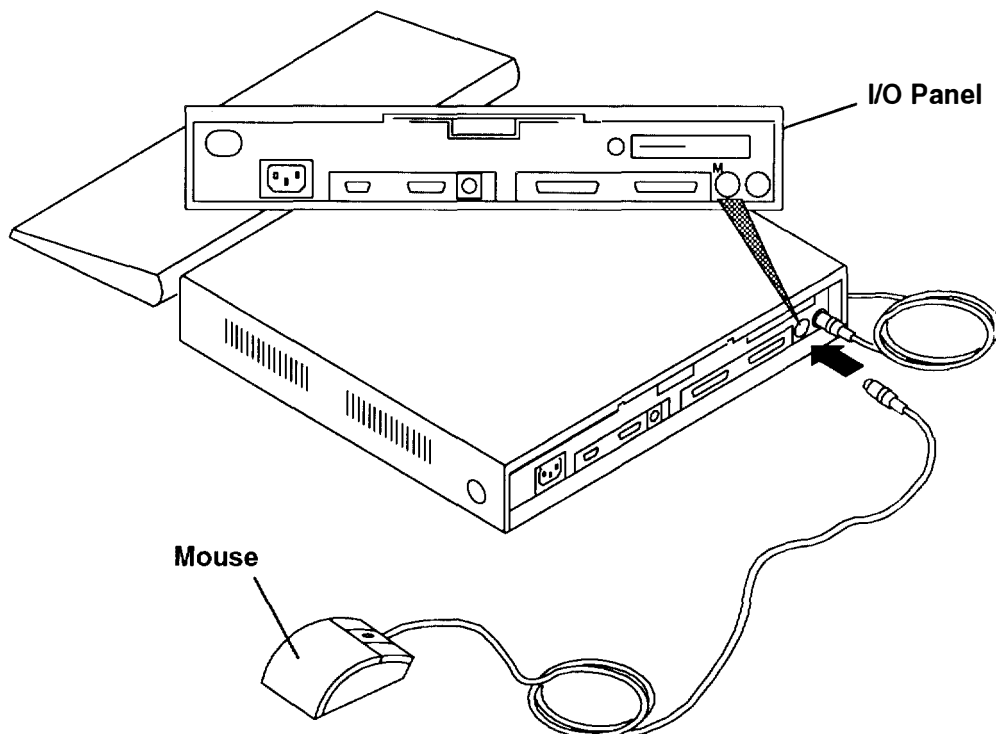

5. Connect the network cables:

- a. If you are using a system board with an Ethernet thin network connection, you must use a BNC-style coaxial "T" connector as shown. To prevent signal weakening or loss, the stub length of the connector (the portion extending from the I/O panel to the cable) should be a maximum of 2.5 cm (1 inch) in length.

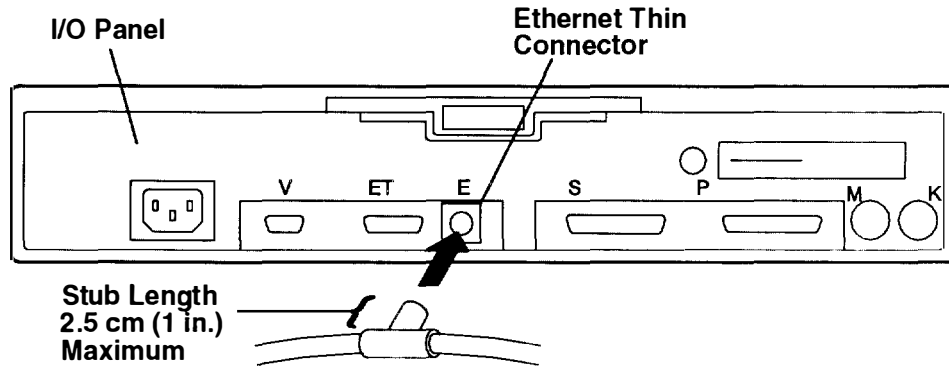

- b. If you are using a system board with an Ethernet thick (D-Shell) connection, connect the cable as shown.

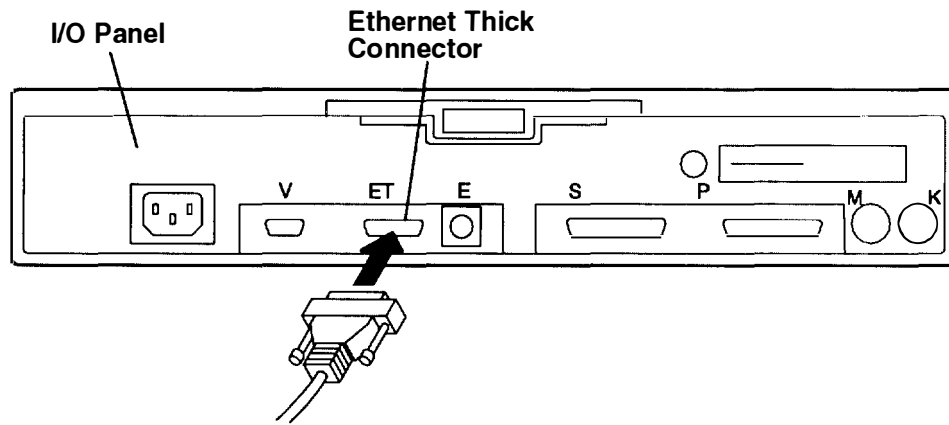

- c. If you are using a system board with an Ethernet twisted-pair connection, you must use a twisted-pair cable adapter as shown.

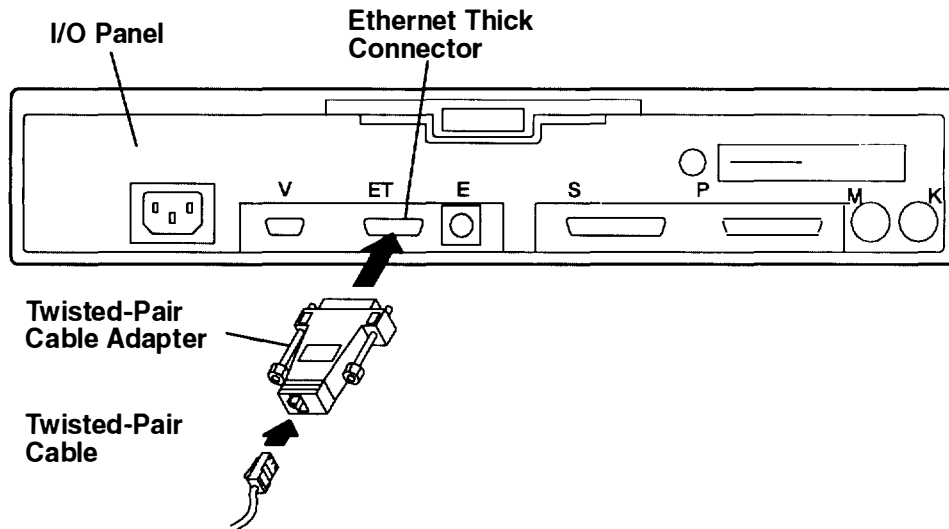

- d. If you are using a system board with a Token-Ring connection, connect the cable as shown.

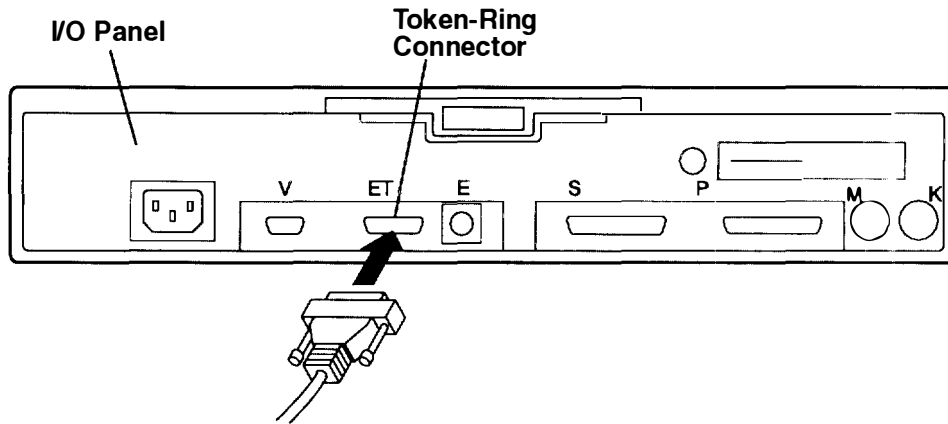

6. Connect any serial and parallel devices you will use with your Xstation.
- a. Connect the serial device to the port labeled S. If you are using a serial port fan out cable, connect the serial devices to ports S1 and S2.
 - b. Connect the parallel device to the port labeled P.

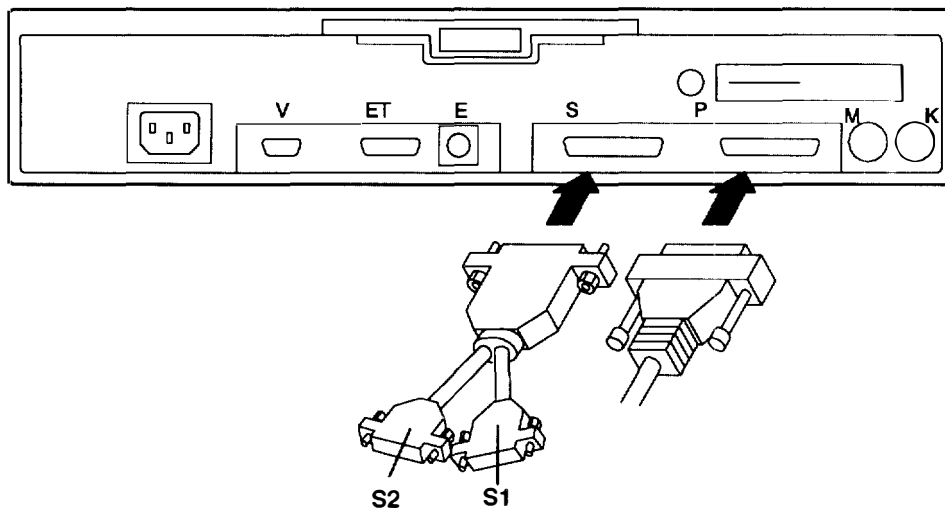

7. Place the display close to the Xstation system unit and plug the display cable into the Xstation I/O panel as shown. Some displays only need the RGB BNC-style connectors. If the display is rolling or is unreadable, disconnect the horizontal (white) and vertical (black) connectors.

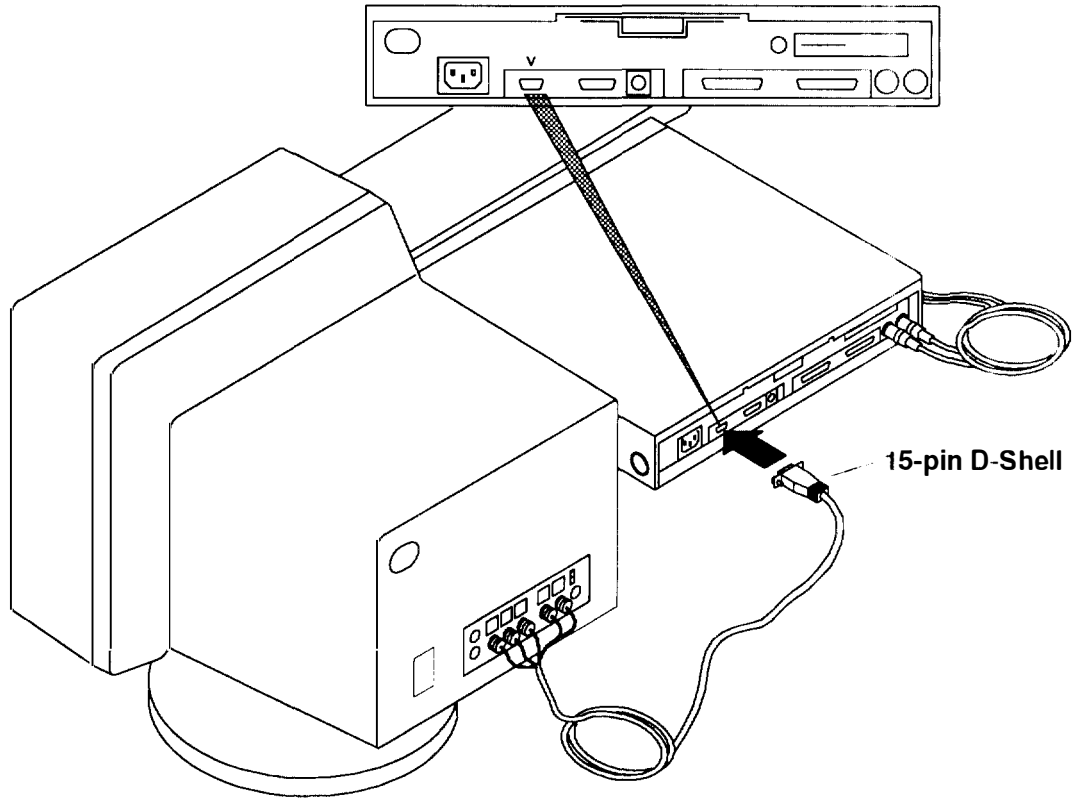

8. If you are using a 6091 or 6091i display with the Xstation, you must:
 - a. Use an FCC-required signal cable such as Part Number 58F2901 or equivalent.
 - b. Set the Sync Input Impedance Switch to Position 1.
 - c. For the 6091-19 Display, set the Mode Switch to Position 2 for 60 Hz operation or to Position 3 for 67 Hz operation.
 - d. For the 6091-16 Display, press the Mode Button "in" for 77 Hz operation or leave it "out" for 60 Hz operation.

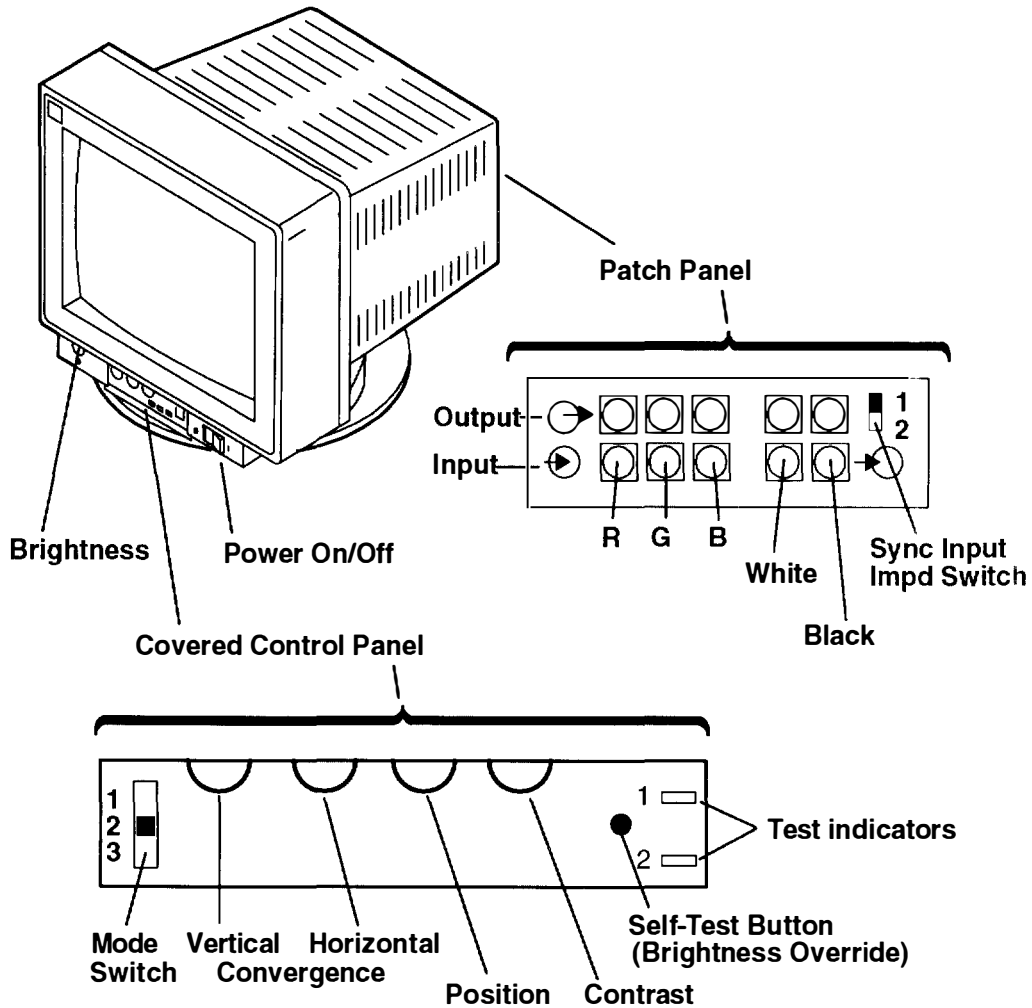

- e. Verify that the display jumpers inside the Xstation are properly set to provide the display frequency indicated by the mode switch on the display. See page 2-10 for a table of display jumper settings.

9. Connect the power cables to the Xstation, display, and any attached devices.

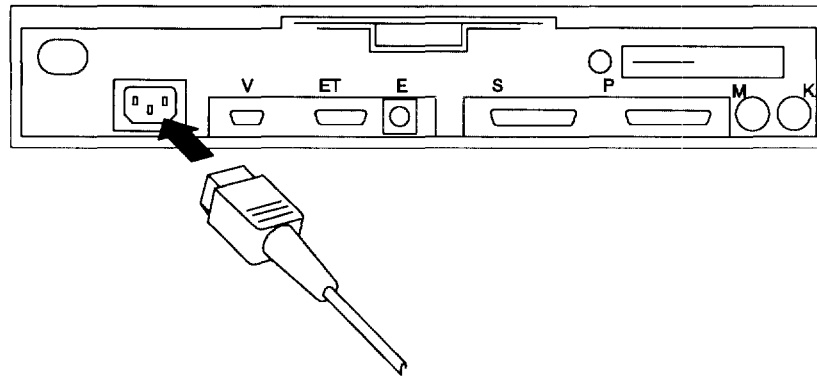

10. Plug the Xstation and display power cords into electrical power outlets.

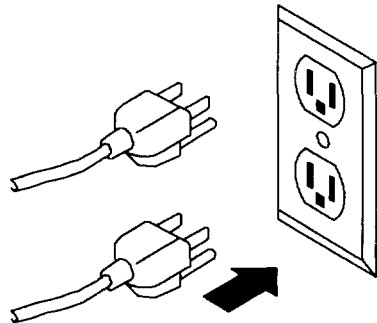

Step 4. Position the Xstation

The hardware portion of your Xstation is now installed. Now, you can position your Xstation and display for use.

1. Choose a place for your Xstation. Make sure that you allow sufficient space behind your Xstation for service, cable attachment, and cable removal.

Warning: Do not place the Xstation on top of any object or surface that will restrict airflow to the chassis. Doing so could prevent proper cooling of the Xstation and cause overheating of system components.

2. Choose a place for your Xstation display. The cover of your Xstation is designed to physically support displays that weigh up to 43Kg (95 pounds). To use a heavier display such as a 6091-23 display, place the Xstation system unit to one side of the display.

Note: Carrying or moving heavy displays may require two persons.

3. A stand is available that allows the Xstation to operate in the vertical position. To use the vertical stand:
 - a. Assemble the vertical stand if you have not already done so.
 - b. Place the Xstation in the vertical stand as shown in this illustration. The Xstation must be in this position (power switch to the top) to allow for proper cooling.
 - c. If the Xstation does not fit in the stand, use the screws on the bottom of the stand to adjust to the proper size.

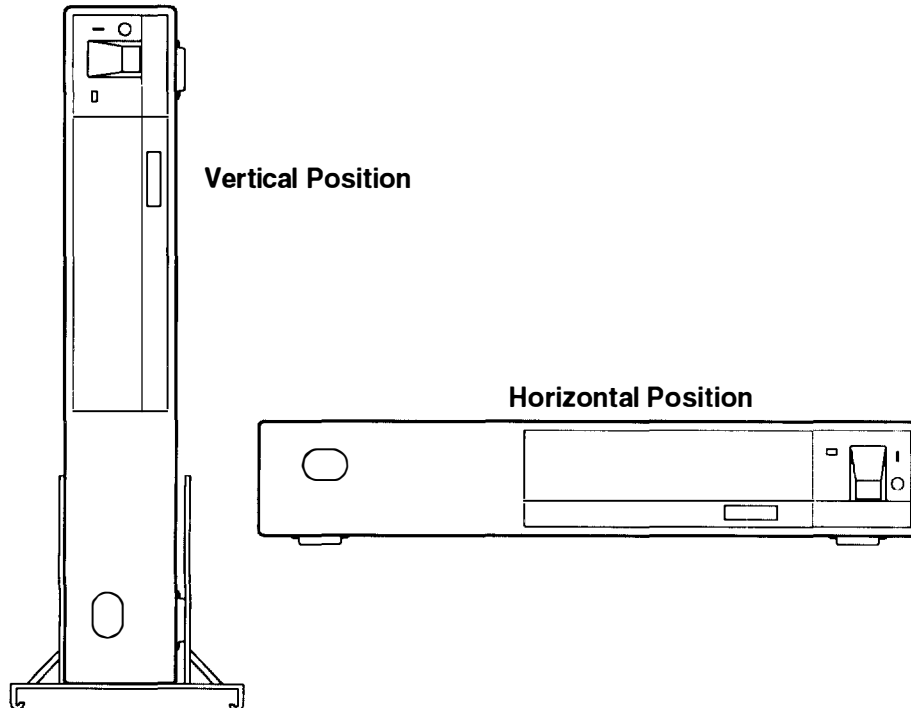

4. If you want to secure your Xstation using the security protection port, refer to Appendix B, "Securing the Xstation."

Your hardware is now completely installed and positioned for use. Proceed to Chapter 3, "Xstation Configuration and Startup" to start the Xstation and establish a network connection.

Chapter 2. Optional Features Installation

DANGER

An electrical outlet that is not correctly wired could place hazardous voltage on metal parts of the system or the devices that attach to the system. It is the responsibility of the customer to ensure that the outlet is correctly wired and grounded to prevent an electrical shock.

Before installing or removing signal cables, ensure that the power cables for the system unit and all attached devices are unplugged.

When adding or removing any additional devices to or from the system, ensure that the power cables for those devices are unplugged before the signal cables are connected. If possible, disconnect all power cables from the existing system before you add a device.

Use one hand, when possible, to connect or disconnect signal cables to prevent a possible shock from touching two surfaces with different electrical potentials.

During an electrical storm, do not connect cables for display stations, printers, telephones, or station protectors for communications lines.

CAUTION:

This product is equipped with a 3-wire power cable and plug for the user's safety. Use this power cable in conjunction with a properly grounded electrical outlet to avoid electrical shock.

Handling Static-Sensitive Devices

Warning: System boards, SIMMs, and FLASH cards are sensitive to static electricity discharge. These devices are wrapped in antistatic bags to prevent this damage.

Take the following precautions:

- If you have an antistatic wrist strap available, use it while handling the device.
- Do not remove the device from the antistatic bag until you are ready to install the device in the system unit.
- With the device still in its antistatic bag, touch the bag to a metal frame of the system.
- Grasp cards and boards by the edges. Avoid touching the solder joints or pins.
- If you need to lay the device down while it is out of the antistatic bag, lay it on the antistatic bag. Before picking it up again, touch the antistatic bag and the metal frame of the system unit at the same time.
- Handle the devices carefully in order to prevent permanent damage.

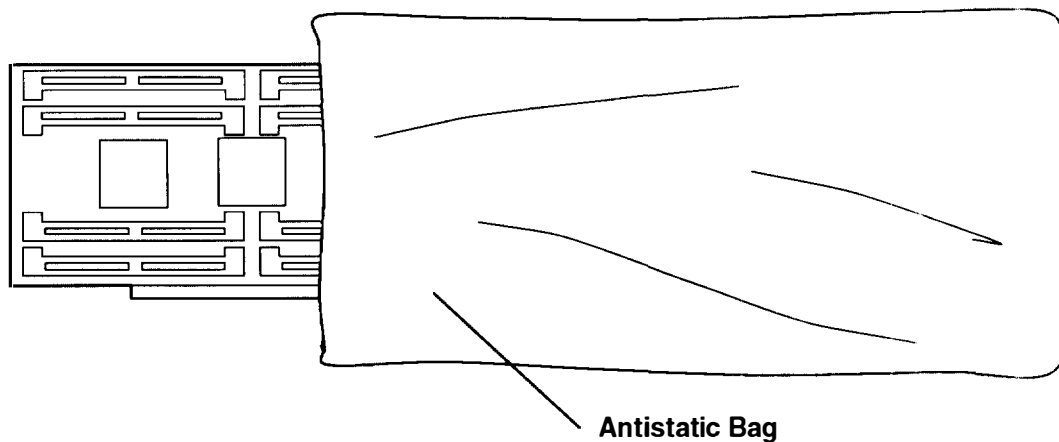

Remove the Chassis Assembly

1. If installed, unlock and remove the customer security protection device in the back right-hand corner of the Xstation chassis.
2. Set the Xstation system unit, display, and attached device power switches to Off (O).

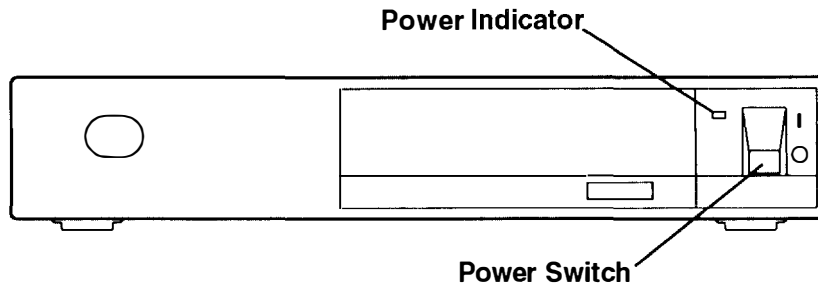

3. If you have not already done so, unplug the system unit power cable, display power cable, and attached device power cables from electrical power outlets.
4. Press down on each side of the plastic tab that extends from the upper edge of the rear cover. When the latches disengage, pull on the plastic tab, and slide out the chassis and power supply as a single unit. Remove any cables attached to the I/O panel that restrict movement as the chassis assembly is extended.
5. With one hand, touch any metal surface of the chassis to minimize static electrical charges before handling any internal component.

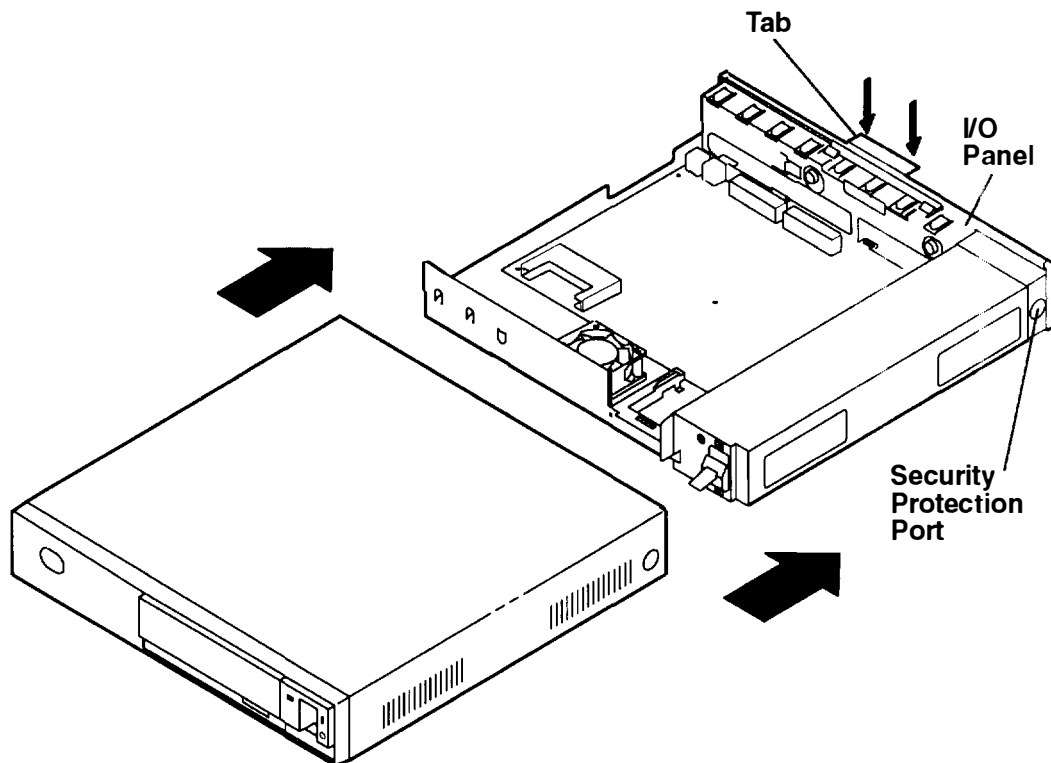

6. Proceed to the Options Checklist on page 2-4.

Options Checklist

Check which options you want to install, then go to the pages indicated for the options you have checked:

- Install Optional SIMMs **Page 2-5**
- Install Optional FLASH Card **Page 2-7**
- Configure Ethernet (to thick, thin, or twisted-pair) **Page 2-8**
- Configure System Jumpers **Pages 2-10 through 2-13**
- Install an Optional Serial Port Fan Out Cable **Page 2-15.**

Install Optional SIMMs

Single Inline Memory Modules (SIMMs) can be installed in your Xstation for extra font and data storage. Before beginning installation, verify that you have SIMMs compatible with the Xstation 140.

1. Turn the chassis so that the power switch faces you, then locate the SIMM sockets (J42 and J43) in the front right-hand corner of the Xstation system board.

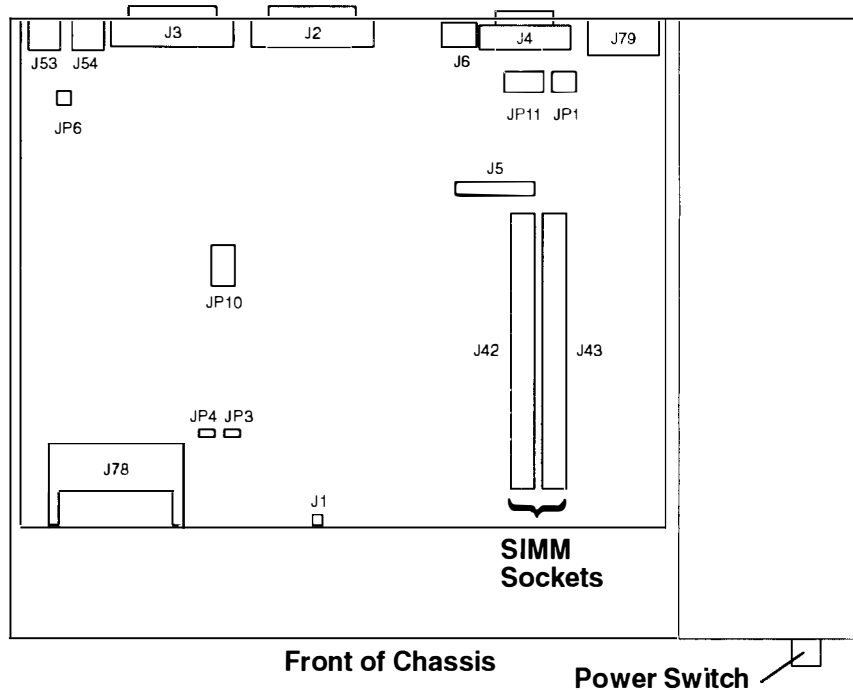

2. If it is necessary to remove any previously installed SIMMs, perform the following steps:
 - a. With one hand, momentarily touch any metal surface of the system unit to minimize static electrical charges, and then touch a SIMM.
 - b. Press both locking tabs outward to release the SIMM.
 - c. While pressing the locking tabs outward, tilt the SIMM forward, and pull it out of the socket.

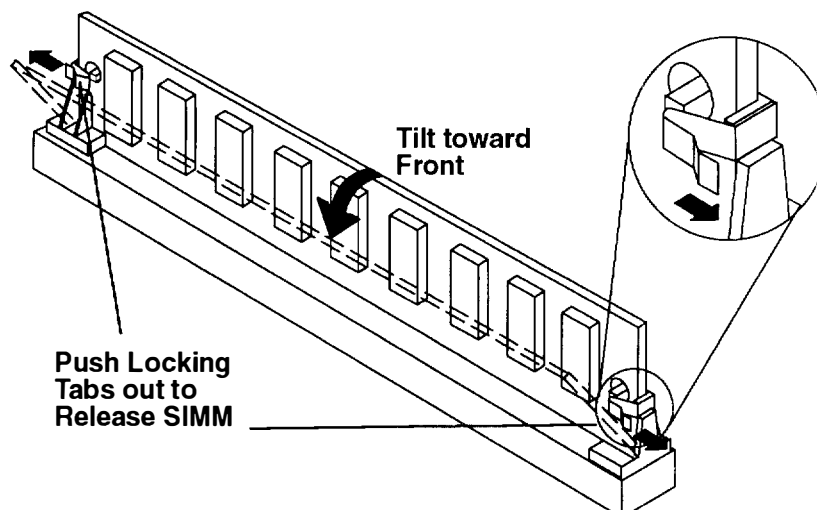

3. To install the SIMMs:

Note: If only one SIMM is installed, it should be placed in the rightmost slot (J43). If two SIMMs are installed, place the SIMM with more memory in slot J43.

- a. With one hand, momentarily touch any metal surface of the system unit to minimize static electrical charges, and then pick up a SIMM.
- b. Align the SIMM with the notch toward the back of the chassis as shown in the following diagram.

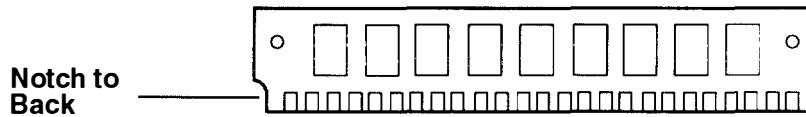

- c. Insert the SIMM at an angle in the next unused socket, and tilt the SIMM towards the side of the chassis to a vertical position. When the SIMM is at the proper upright position, the locking tabs on both ends of the socket will snap into place in front of the SIMM.

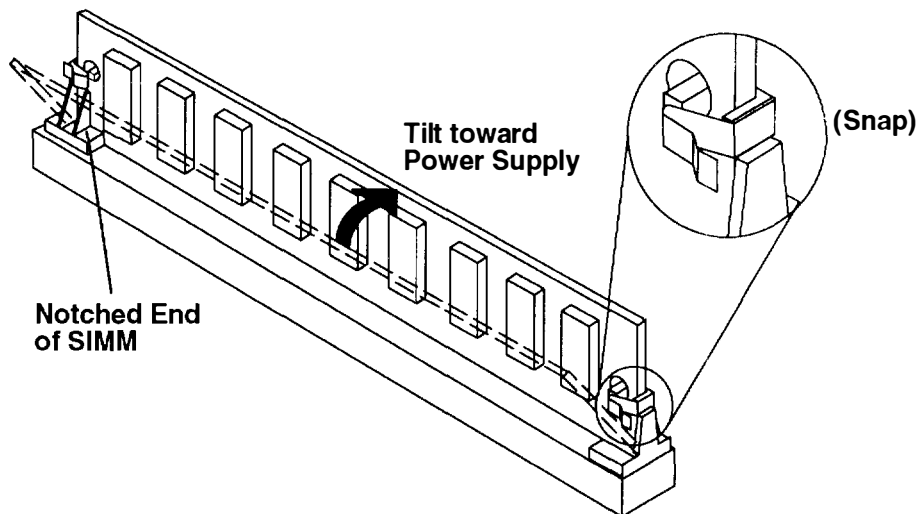

Do you have more options to install?

No Go to "Replace the Chassis Assembly" on page 2-14.

Yes Return to the "Options Checklist" on page 2-4.

Install Optional FLASH Card

Unlike the SIMMs and the dynamic RAM on the Xstation 140 system board, FLASH memory retains its contents even when the Xstation is turned off. If you choose, you can install an optional FLASH card which can be used to hold additional fonts, data, and applications. The FLASH card is available in various capacities.

To install a FLASH card, follow the steps below:

1. One end of the FLASH card contains small sockets which fit over the pins of the FLASH card connector on the Xstation planar. Look closely at the end of the FLASH card that contains the sockets: the left side has a groove down the middle of the long side; the right side has a groove down the top of the long side. These grooves allow the FLASH card to be inserted into the FLASH card connector only one way.

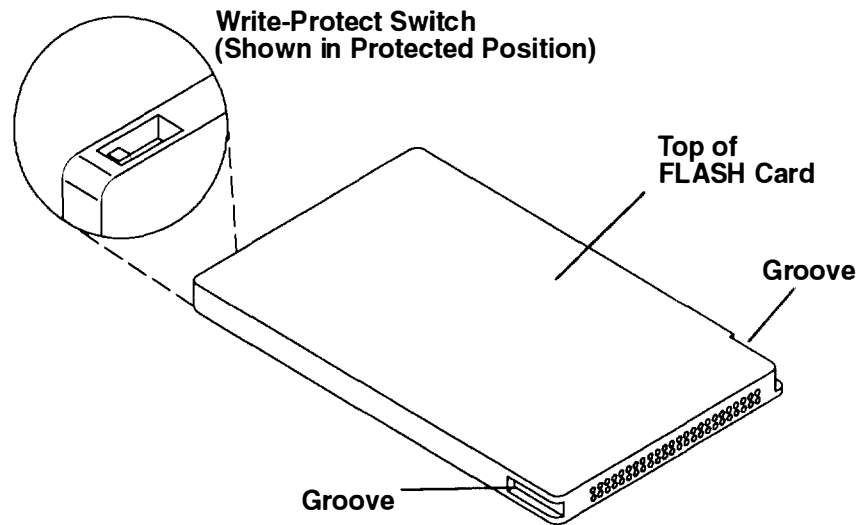

2. Turn the FLASH card so that the sockets face the pins in the FLASH card connector

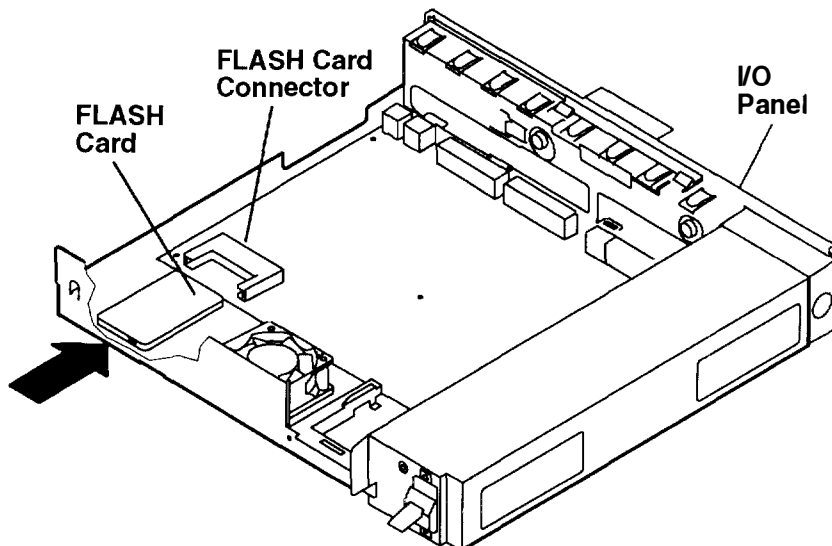

3. Insert the FLASH card into the FLASH card connector.

Do you have more options to install?

No Go to "Replace the Chassis Assembly" on page 2-14.

Yes Return to the "Options Checklist" on page 2-4.

Configure Ethernet

If you have an Ethernet system board, you have the option of using a “thin” coaxial connector, a “thick” 15-pin D-Shell connector, or a “twisted-pair” connector. The Ethernet network connection is factory-set in the thin configuration.

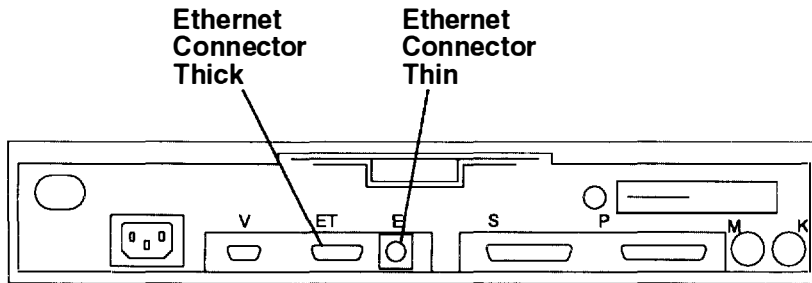

1. Turn the chassis so that the power switch faces you.
2. Locate the Ethernet jumpers on the system board.
3. If necessary, change all eleven of the individual jumpers to either the thin or thick setting as shown.

If you are using:

- | | |
|-------------------------------|----------------------------------|
| Thin (10Base2) | Set jumpers to “thin” position. |
| Thick (10Base5) | Set jumpers to “thick” position. |
| Twisted Pair (10BaseT) | Set jumpers to “thin” position. |

Note: No external converter is required.

Thick Position

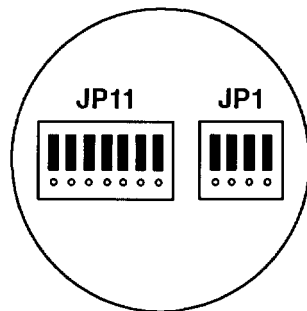

Thin Position

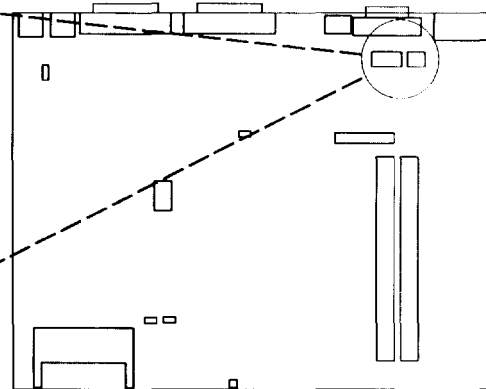
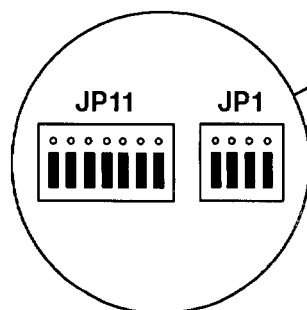

4. To use a twisted-pair connector, you must connect a twisted-pair cable adapter to the thick Ethernet connector. The twisted-pair cable connects to the twisted-pair cable adapter.

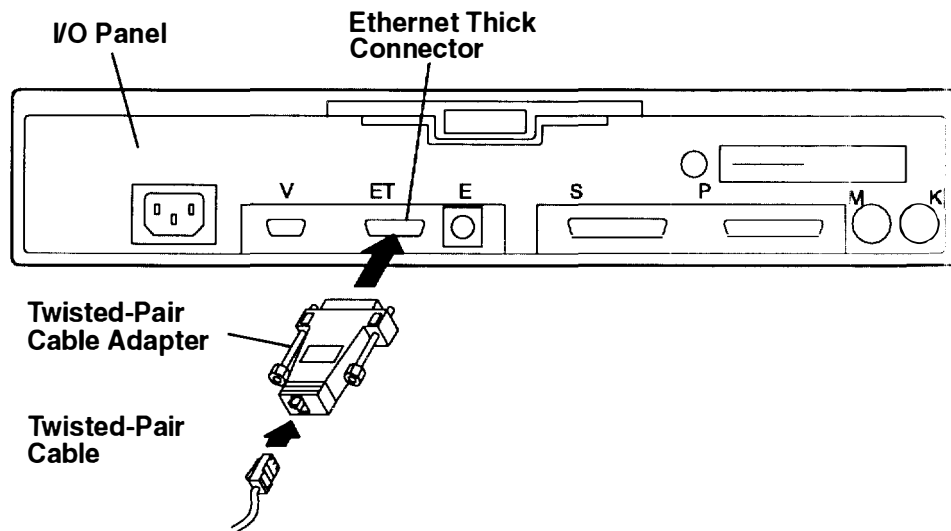

Do you have more options to install?

No Go to “Replace the Chassis Assembly” on page 2-14.

Yes Return to the “Options Checklist” on page 2-4.

Configure System Jumpers

Display Jumpers

The display jumpers allow you to use several different types of displays with the Xstation. Looking at the front of the Xstation with the power switch facing you, the first four jumpers (labeled 0, 1, 2, and 3 in the following figure) are those used for display configuration.

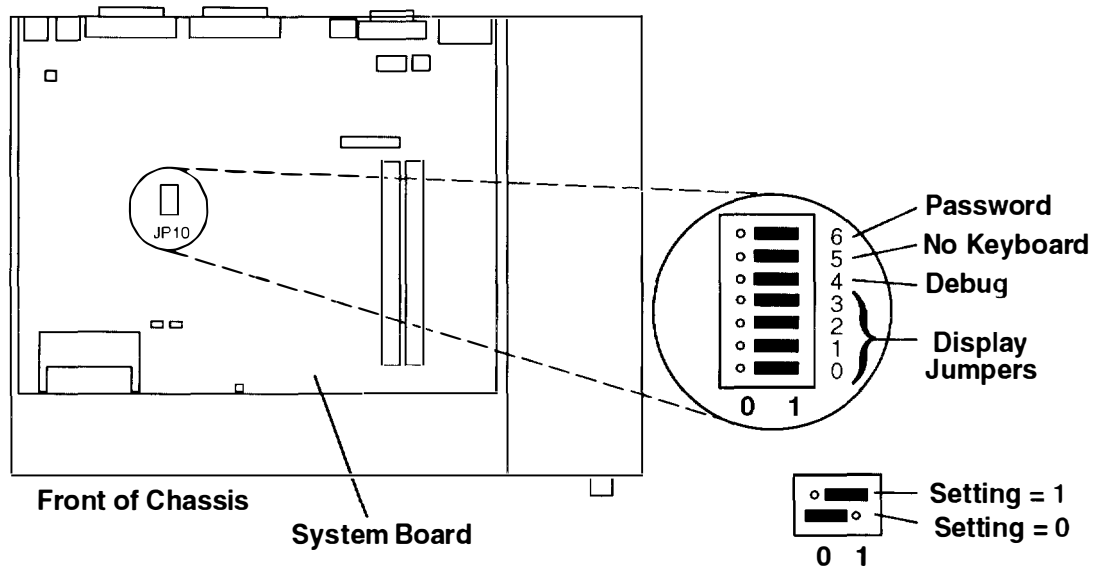

These four jumpers are factory-set to 1111. To change the displays jumper setting, look up the proper setting in the table below, then record that setting here when you configure the system jumpers inside your Xstation.

Note: Powering up the Xstation without the display attached resets the Xstation display parameters. This may resolve some unreadable screen conditions

The jumper setting was changed from the default (1111) to _____.

Display Type	Hex Code	Display Jumper 3 2 1 0	Screen Resolution	Frame Rate (Hz)	Mode Switch/ Button	Display Cable
8508 19" Mono	F777	1 1 1 1	1280 x 1024 x 8	67	-	-
8517 17"	F22A	1 1 1 1	1024 x 768 x 8	69.96	-	-
5081-016	F444	1 1 1 1	1280 x 1024 x 8	60	-	58F2901
5081-019	F444	1 1 1 1	1280 x 1024 x 8	60	-	58F2901
6091-016	F444	1 1 1 1	1280 x 1024 x 8	60	out	58F2901
	D444	1 1 0 1		77	in	
6091-019	F444	1 1 1 1	1280 x 1024 x 8	60	2	58F2901
	E444	1 1 1 0		67	3	
6091-019i	F444	1 1 1 1	1280 x 1024 x 8	60	-	58F2901
	D444	1 1 0 1		77	-	
6091-023	F444	1 1 1 1	1280 x 1024 x 8	60	-	58F2901
1091-051	F7F7	1 1 1 1	1280 x 1024 x 8	72	-	09G3588

Display Type	Hex Code	Display Jumper 3 2 1 0	Screen Resolution	Frame Rate (Hz)	Mode Switch/ Button	Display Cable
ValuePoint 6314, 6319	FAAA	1 1 1 1	1024 x 768	60	-	-
	2AAA	0 0 1 0		70	-	-
ValuePoint 6317, 6324, 6325, 9524, 9525	FAAA	1 1 1 1	1024 x 768	60	-	-
	2AAA	0 0 1 0		70	-	-
	BAAA	1 0 1 1	1280 x 1024	75.8	-	-
	AAAA	1 0 1 0		60	-	-
ValuePoint 9527, 9521	FAAA	1 1 1 1	1024 x 768	60	-	-
	2AAA	0 0 1 0		70	-	-
	AAAA	1 0 1 0	1280 x 1024	60	-	-
	DAAA	1 1 0 1		77	-	-
POWERdisplay 16	F444 D444	1 1 1 1 1 1 0 1	1280 x 1024 x 8	60 77	out in	58F2901
POWERdisplay 16S	F7F7	1 1 1 1	1280 x 1024 x 8	72		09G3588
POWERdisplay 19	F444 D444	1 1 1 1 1 1 0 1	1280 x 1024 x 8	60 77	- -	58F2901

Notes:

1. After making changes to the display jumper settings, verify that the display's Mode Switch or Button is in the position indicated in the table above. The Mode Switch or Button is located below the display screen as shown on page 1-8.
2. The Hex Code has four digits. The first digit identifies the display jumper setting. The last three digits are the display ID code.
3. The Hex Code can be verified on the Base Configuration Screen of the Xstation 140 Configuration Menus.

Password-Reset Jumper

The Xstation configuration described in Chapter 3 can be protected by a password. To remove this protection (for example, if the password has been lost), move the system jumper labeled 6 in the following figure to the opposite setting. If the password-reset jumper is in the 0 position, move it to the 1 position; if the password-reset jumper is in the 1 position, move it to the 0 position.

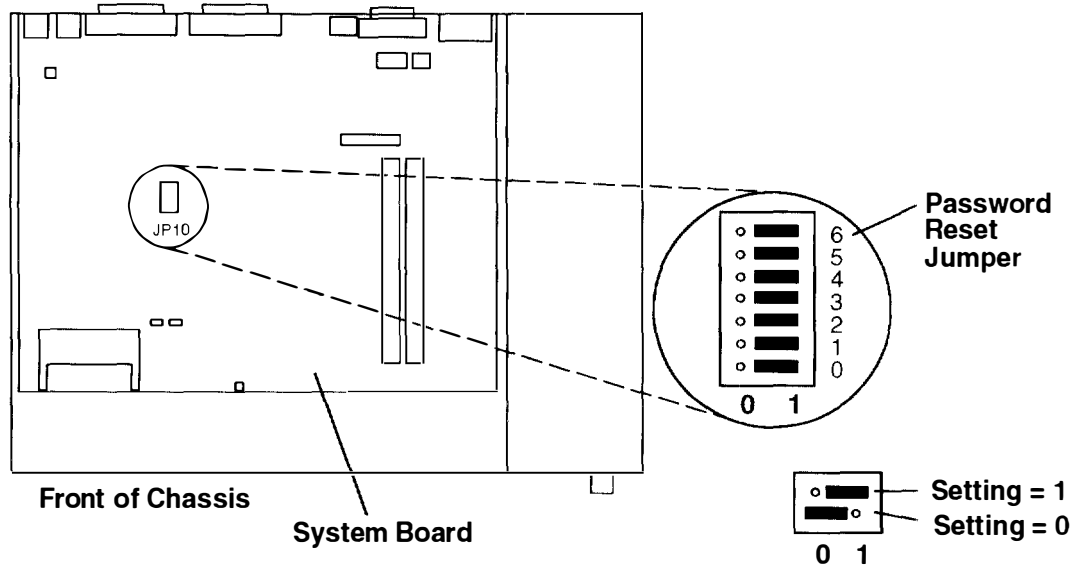

Recover Boot Jumper

The recover boot jumper is used only for emergency recovery from a power outage while Base FLASH is being updated. Do not change this jumper without instructions from trained service personnel.

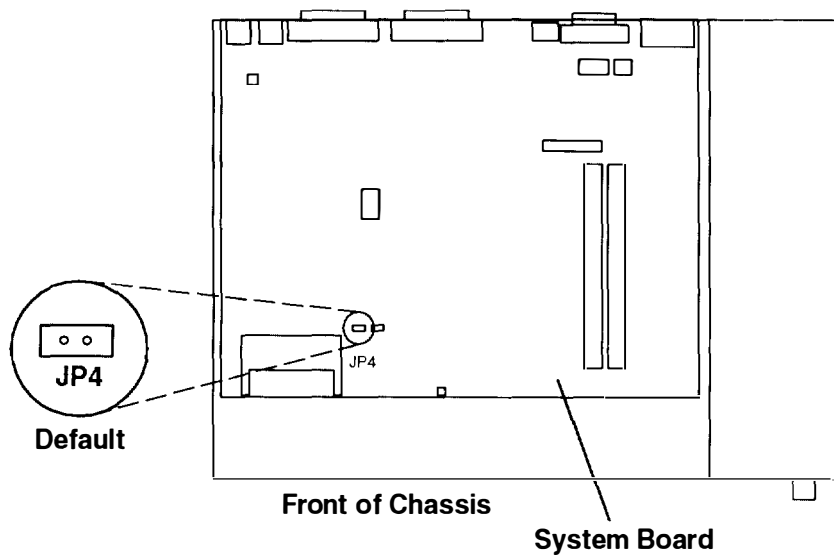

Alternate Boot Jumper

POST code is generally read from the base FLASH on the system board. To automatically boot from the optional FLASH card, the JP3 pins must be jumpered as shown in position 2.

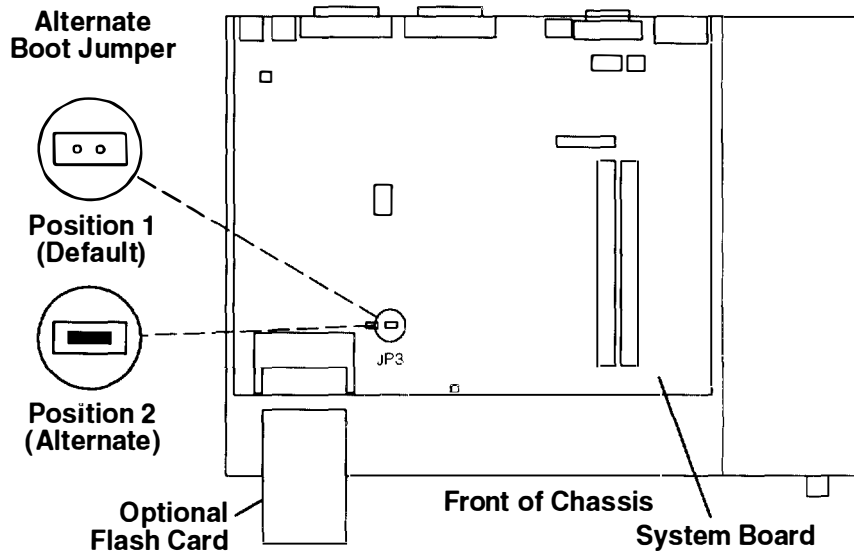

Speaker Jumper

The speaker jumper is used to select sound output. The factory position (1) selects sound to be output through the keyboard speaker. Position 2 must be jumpered to select sound to be output through the internal beeper.

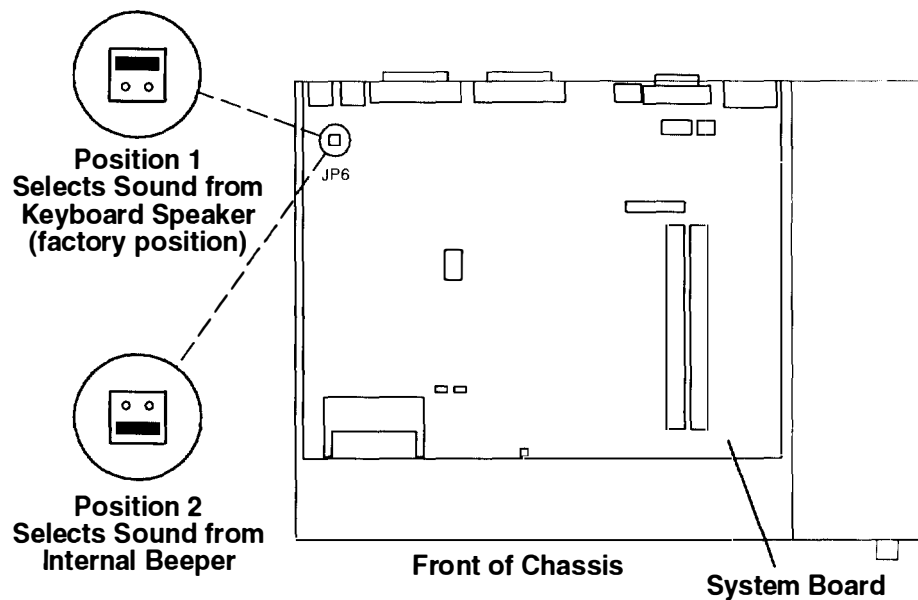

Do you have more options to install?

No Go to "Replace the Chassis Assembly" on page 2-14.

Yes Return to the "Options Checklist" on page 2-4.

Replace the Chassis Assembly

1. Ensure that the power switch is in the Off position (down). The chassis cannot be replaced if the power switch is On (up).
2. Slide the chassis assembly back into the cover until the latches click.

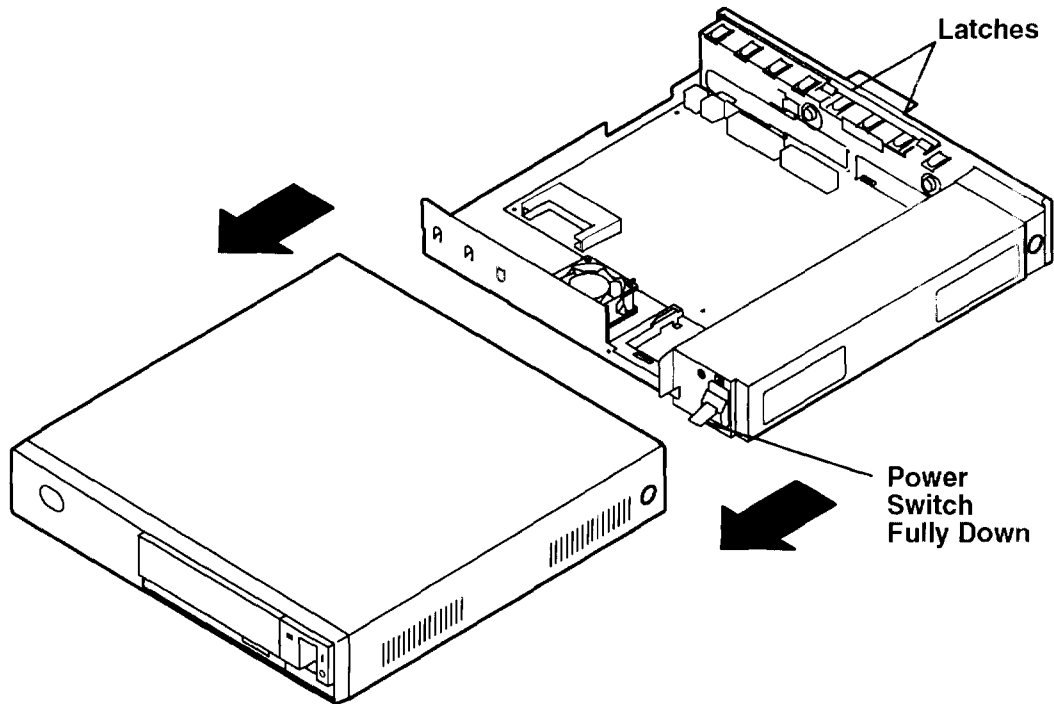

3. Pull gently on the rear tab to ensure that the chassis is locked into position.

Do you want to attach an optional serial port fan out cable?

No Return to "Step 3. Connect the Cables" on page 1-3.

Yes Continue to "Install an Optional Serial Port Fan Out Cable" on page 2-15.

Install an Optional Serial Port Fan Out Cable

The optional serial port fan out cable provides an additional serial port for your Xstation. To install a fan out cable, first remove any device already attached to the Xstation serial port.

1. Attach the serial port fan out cable to the 25 pin D-shell connector (S).

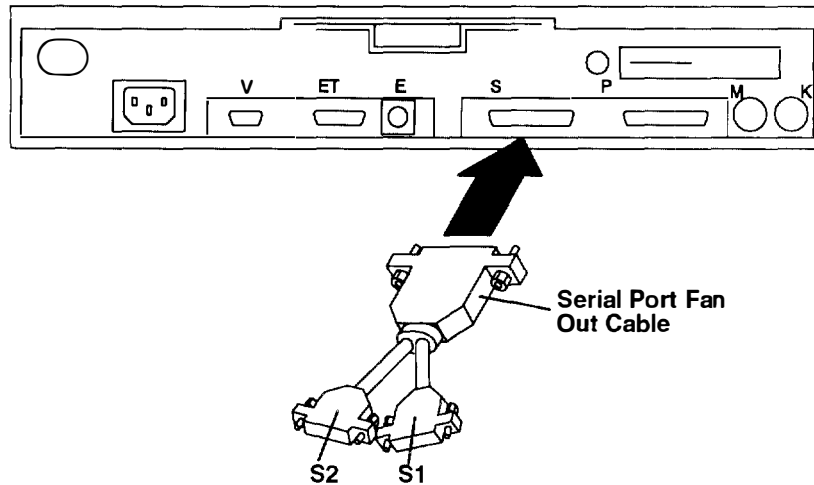

2. Plug any device that had been connected to the Xstation serial port into the serial port fan out cable connector marked "S1."
3. If desired, connect a second device to the connector marked "S2."

Did you come to Chapter 2 from Chapter 1?

- No** The hardware installation is complete; proceed to Chapter 3.
- Yes** Return to "Step 3. Connect the Cables" on page 1-3 to complete the hardware setup of your Xstation.

Chapter 3. Xstation Configuration and Startup

To ready the Xstation for use, you must now choose the language for the Xstation menus, establish a network connection, and choose your terminal mode.

Step 1. Start the Xstation

Set the display and Xstation power switches to On (1).

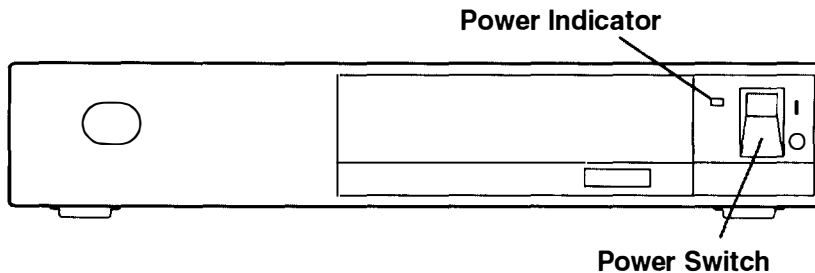

When your Xstation is powered on, a Power-On Self-Test (POST) and built-in diagnostics begin automatically.

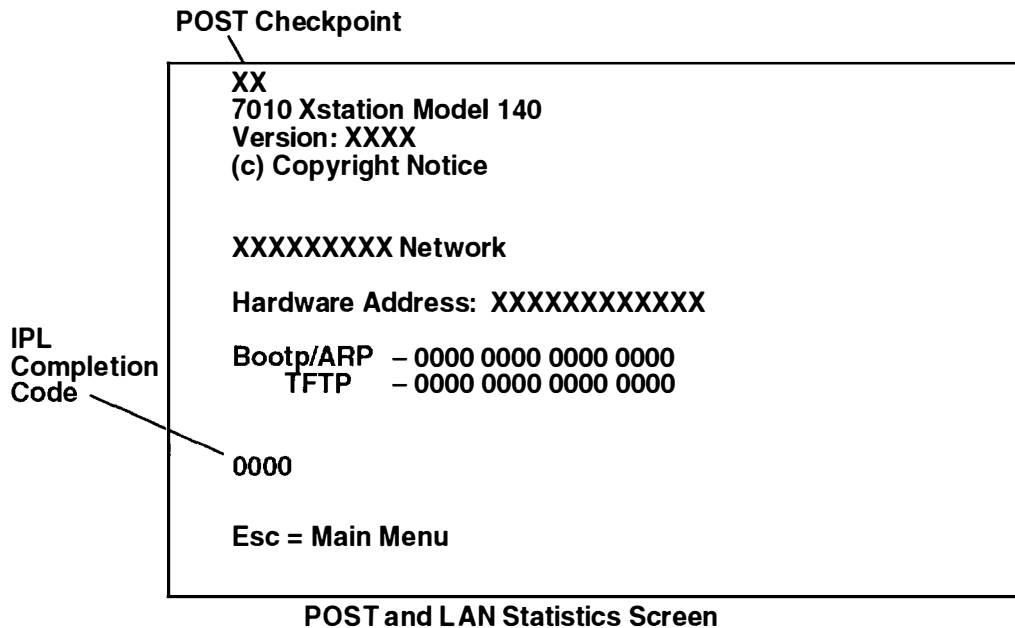

When the POST has successfully completed (one audio beep), the Local Area Network (LAN) statistics should display information for applicable LANs. If the Xstation fails to complete the POST or LAN communications test, go to Chapter 5, "Problem Determination Procedures."

Pressing the Esc key while the POST and LAN statistics screen is displayed or the Alt and Print Screen (SysRq) keys together during an X-Windows session will display the Xstation Main Menu. These graphical menus allow you to change the configuration of your Xstation and run programs to diagnose your Xstation and attached devices. Through these menus, you can also bypass the system boot and telnet to a host using your Xstation's local configuration.

Step 2. Select a Language

If the POST and LAN statistics screen is still displayed, press the Esc key to display the Xstation Main Menu.

If you have entered an X-Windows session, press the Alt and Print Screen (SysRq) keys at the same time to display the Xstation Main Menu. The Main Menu is factory-set to display in English.

The screenshot shows the Xstation Main Menu interface. At the top left is a circular logo with the word "logo" inside. To its right is a rectangular box containing the text "Copyright Statement" and "Version" below it. Below these are three sections of options, each with a title and a list of items:

- Xstation Session:**
 - X-Windows
 - Telnet Terminal
 - Asynchronous Terminal
- Configuration:**
 - Select Menu Language . . . English (U.S.)
 - Xstation Configuration
 - Base Configuration
- Utilities:**
 - Startup Messages
 - Statistics and Logs
 - Test the Terminal

At the bottom of the menu are four buttons: "Save Changes", "Restore Defaults", "Reboot", and "Help".

Xstation Session

This section controls the Xstation's mode of operation.

X-Windows

This selection allows the Xstation to run an X-Windows session according to its configuration. This configuration can be acquired one of two ways:

- Centrally** The Xstation has BOOTP enabled and the host's configuration overrides the Xstation's local configuration.
- Locally** The Xstation has BOOTP disabled and provides its own configuration parameters as defined through the Xstation's Main Menu.

Telnet Terminal

This selection allows the Xstation to configure and run a telnet session though the attached LAN.

Asynchronous Terminal

This selection allows the Xstation to configure and run an asynchronous terminal emulation though the serial port. If a serial fan out cable is attached, the terminal emulation can be run through either the S1 or S2 serial ports.

Configuration

This section of the Main Menu controls the language of the Xstation menus and the Xstation's configuration.

Select Menu Language

To select the language for the Xstation Menus, move the pointer with the mouse and click on the **LIST** button beside **Select Menu Language**. After you do that, the following illustration is displayed. Now, click on the button next to your language selection. Note that the language you select should match your keyboard.

The screenshot shows a graphical user interface for Xstation configuration. At the top left is a circular logo with the word "logo" inside. To its right is a rectangular box labeled "Copyright Statement Version". Below these are three sections of options, each with a title and a list of items:

- Xstation Session:**
 - X-Windows
 - Telnet Terminal
 - Asynchronous Terminal
- Configuration:**
 - Select Menu Language . . . English (U.S.)
 - Xstation Configuration
 - Base Configuration
- Utilities:**
 - Startup Messages
 - Statistics and Logs
 - Test the Terminal

On the right side, there is a box titled "Language Selection" containing a list of languages, each preceded by a diamond symbol:

- ◆ Deutsch
- ◆ English (U.S)
- ◆ Español
- ◆ Français
- ◆ Italiano
- ◆ Nederlands (Belgie)

At the bottom of the window, there are four buttons: "Save Changes", "Restore Defaults", "Reboot", and "Help".

Xstation Configuration

This selection allows you to configure how your Xstation communicates with networks and attached devices. In addition, this section of the Xstation menus allows you to set the startup mode of the Xstation: either the Xstation Main Menu, an X-Windows session, the telnet emulator, or the asynchronous terminal emulator can be automatically displayed after the Xstation completes the POST.

Base Configuration

This selection allows you to view and change the some of the Xstation's base hardware configuration.

Utilities

This section of the Main Menu controls diagnostic information and tests.

Startup Messages

The startup messages displayed by this selection allow you to view (in English only) the initial program load (IPL) progress in order to verify configuration of the Xstation and communication with the host.

Statistics and Logs

This section displays (in English only) the LAN, error, and POST logs.

Test the Terminal

This section provides interactive tests for analyzing the Xstation hardware and attached devices.

Step 3. Establish Network Connection

1. Before you can continue, the system administrator of your host should add your Xstation as a client on the host as described in *Xstation Manager/6000 Version 1.4.1 System Management Guide*. To register your Xstation, the system administrator must know the hardware address of your Xstation. You can obtain the hardware address for your Xstation from the POST and LAN Statistics Screen (shown on page 3-1). You can also obtain the hardware address from the Main Menu by doing the following:
 - a. Click on the button next to **Xstation Configuration**.
 - b. Click on the button next to **Network Parameters**.
 - c. Locate the line that begins with **Hardware Address**.

Note: If so instructed by your system administrator, you can enter a value in the **Alternate Hardware Address** field, but do not choose an address already accessible on the network.

2. Record the hardware address in the following space, then notify your system administrator of your Xstation's hardware address:

Hardware Address: _____

Note: The hardware address consists of 6 hexadecimal numbers for a total of 12 characters. Make sure that you record all 12 characters, including any zeroes at the beginning of the address.

3. Establish the network protocol.
 - If you are using Ethernet, select the the appropriate protocol (**Automatic**, **Ethernet**, or **IEEE 802.3**) on the Network Parameters menu. If you have any doubts about which to select, select **Automatic**; both **Ethernet** and **IEEE 802.3** are attempted and the first response from the host determines the protocol.
 - If you are using Token-Ring, select the appropriate data rate for the network. Select **Automatic**, **4Mbps**, or **16Mbps**. If you select **Automatic**, the correct speed is selected by the host and the Xstation.

Network Parameters	
Ethernet Adapter Protocol	XXXXXXXXXXXX
Alternate Hardware Address	<input type="text"/>
	<input checked="" type="radio"/> Automatic <input type="radio"/> Ethernet <input type="radio"/> IEEE 802.3

Note: If you select the incorrect data rate, the Xstation beacons the ring causing a catastrophic failure of the network.

Network Parameters	
Token-Ring Adapter	XXXXXXXXXXXX
Token-Ring Data Rate	<input type="radio"/> Automatic <input type="radio"/> 4Mbps <input type="radio"/> 16Mbps
Alternate Hardware Address	<input type="text"/>

4. To establish network connection the Xstation 140 can be configured in a variety of ways. A few examples of the Xstation's graphical configuration menus are given for each one of the following configuration scenarios:

- Using broadcast BOOTP on a LAN without gateways or bridges on page 3-7.
- Using direct BOOTP on a LAN that has gateways or bridges on page 3-8.
- Disabling BOOTP and enabling the direct XDMCP mode on page 3-10.
- Configuring a network connection for a non-AIX environment on page 3-12.
- Updating FLASH from the Network on page 3-14.

The four menus that are used are: the Main Menu, the Xstation Configuration menu, the Network Parameters menu, and the File Servers menu.

Note: If the password must be reset, follow the steps in "Password-Reset Jumper" on page 2-12.

5. After you have configured the Xstation for the appropriate network connection and your system administrator notifies you that your Xstation is registered, reboot your Xstation.
6. If your Xstation displays the Main Menu following the POST and LAN Statistics Screen, proceed to "Step 4. Choose Terminal Mode" on page 3-15.

If your Xstation displays a stipple-patterned screen with a small "X," contact your system administrator and request a `login: window`.

Example 1. Using Broadcast BOOTP on a LAN without Gateways or Bridges

If you have previously configured your Xstation with SMIT as described in *Xstation Manager System Management Guide*, and if you are on a simple network, one with no gateways, bridges or routers, your Xstation 140 will establish network connection with the default configuration. To view these, at the Main Menu, select **Xstation Configuration**.

```

Xstation Configuration

Protected Configuration:
 Set Password
 X-Windows
 Network Parameters
 Name Servers
 File Servers
 Font Servers

Non-Protected Configuration:
 Startup Mode . . . X-Windows   List
 Keyboard and Mouse
 Serial Port

_____ Esc _____
Main Menu      Help
  
```

Now select **Network Parameters** to view these parameters. The following default parameters will be displayed:

```

Network Parameters

Ethernet Adapter      XXXXXXXXXXXXX
Protocol              Automatic  Ethernet  IEEE 802.3
Alternate Hardware Address _____
BOOTP                Broadcast (default)  Direct  Disable
Boot Preference      Base FLASH  TFTP  Optional FLASH
Terminal Internet Address
Host Internet Address
Gateway Internet Address
Subnet Mask
XDMCP Query Type    None      List
XDMCP Internet Address
Automatic update of FLASH  Enable  Disable  On Next Reboot
Default Telnet Host _____
Boot File Name
Slip Terminal Internet Address
Slip Remote Host Internet Address
Slip Subnet Mask
Slip Dial String

_____ Esc _____
Xstation Configuration  Serial Port  Help
  
```

Return to **Xstation Configuration**, then **Main Menu**.

Example 2. Using Direct BOOTP on a LAN that has Gateways or Bridges

If you have previously configured your Xstation with SMIT as described in *Xstation Manager System Management Guide*, and if your Xstation and host are connected by a gateway or bridge then you will use this configuration method. At the Main Menu select **Xstation Configuration**, then select **Network Parameters**. Modify the parameters of the menu to look like the following example:

Network Parameters	
Ethernet Adapter Protocol	XXXXXXXXXXXXX <input checked="" type="checkbox"/> Automatic <input type="checkbox"/> Ethernet <input type="checkbox"/> IEEE 802.3
Alternate Hardware Address	<input type="text"/>
BOOTP	<input type="checkbox"/> Broadcast (default) <input checked="" type="checkbox"/> Direct <input type="checkbox"/> Disable
Boot Preference	<input checked="" type="checkbox"/> Base FLASH <input type="checkbox"/> TFTP <input type="checkbox"/> Optional FLASH
Terminal Internet Address	<input type="text" value="XXX.XXX.XXX.XXX"/>
Host Internet Address	<input type="text" value="XXX.XXX.XXX.XXX"/>
Gateway Internet Address	<input type="text" value="XXX.XXX.XXX.XXX"/>
Subnet Mask	<input type="text" value="XXX.XXX.XXX.XXX"/>
XDMCP Query Type	None <input type="button" value="List"/>
XDMCP Internet Address	<input type="text"/>
Automatic update of FLASH	<input checked="" type="checkbox"/> Enable <input type="checkbox"/> Disable <input type="checkbox"/> On Next Reboot
Default Telnet Host	<input type="text"/>
Boot File Name	<input type="text"/>
Slip Terminal Internet Address	<input type="text"/>
Slip Remote Host Internet Address	<input type="text"/>
Slip Subnet Mask	<input type="text"/>
Slip Dial String	<input type="text"/>
Esc	
<input type="button" value="Xstation Configuration"/> <input type="button" value="Serial Port"/> <input type="button" value="Help"/>	

Note: If the Xstation and host are on the same Internet network but are connected by a bridge (such as an 8209 bridge), which does not forward BOOTP broadcasts, this method will NOT be used. This configuration will require disabling BOOTP discussed in "Disabling BOOTP and enabling the direct XDMCP mode" on page 3-10.

Return to Xstation Configuration, then select **File Servers**. Modify the parameters of the menu to look like the following example:

<u>File Servers</u>	
Primary File Server: x_st_mgrd	List
Host Internet Address	XXX.XXX.XXX.XXX
Port	9000
Default Path	/usr/lib/X11/
Secondary File Server: x_st_mgrd	List
Host Internet Address	XXX.XXX.XXX.XXX
Port	9000
Default Path	/usr/lpp/x_st_mgr/
Esc	
Xstation Configuration	Help

Note: The *Port* number needs to match the one in /etc/services for x_st_mgrd, the one used to define an Xstation Network Type under SMIT.

Return to Xstation Configuration, then Main Menu. Select **Save Changes** and then select **Reboot**.

Example 3. Disabling BOOTP and Enabling the Direct XDMCP Mode

If you have previously configured your Xstation with SMIT as described in *Xstation Manager System Management Guide* to have XDM manage your Xterminal and your Xstation and host are on the same Internet network but are connected by a bridge (such as an 8209 bridge) which does not forward BOOTP broadcasts, then this method will be used.

At the Main Menu select **Xstation Configuration**, then select **Network Parameters**. Modify the parameters of the menu to look like the following example:

```

                                Network Parameters
Ethernet Adapter                XXXXXXXXXXXX
Protocol                        Automatic  Ethernet  IEEE 802.3
Alternate Hardware Address      _____
BOOTP                           Broadcast (default)  Direct  Disable
Boot Preference                 Base FLASH  TFTP  Optional FLASH
Terminal Internet Address       XXX.XXX.XXX.XXX
Host Internet Address           XXX.XXX.XXX.XXX
Gateway Internet Address        XXX.XXX.XXX.XXX
Subnet Mask                     XXX.XXX.XXX.XXX
XDMCP Query Type               Direct 
XDMCP Internet Address          XXX.XXX.XXX.XXX
Automatic update of FLASH       Enable  Disable  On Next Reboot
Default Telnet Host             XXX.XXX.XXX.XXX
Boot File Name                  /etc/x_st_mgr/X140serv
Slip Terminal Internet Address
Slip Remote Host Internet Address
Slip Subnet Mask
Slip Dial String

Esc
Xstation Configuration Serial Port Help
```

Return to Xstation Configuration, then select **File Servers**. Modify the parameters of the menu to look like the following example:

File Servers	
Primary File Server: x_st_mgrd	List
Host Internet Address	XXX.XXX.XXX.XXX
Port	9000
Default Path	/usr/lib/X11/
Secondary File Server: x_st_mgrd	List
Host Internet Address	XXX.XXX.XXX.XXX
Port	9000
Default Path	/usr/lib/X11/
Esc	
Xstation Configuration	Help

Note: The *Port* number needs to match the one in /etc/services for x_st_mgrd, which is the one used to define an Xstation Network Type under SMIT.

Return to Xstation Configuration, then Main Menu. Select **Save Changes** and then select **Reboot**.

Example 4. Configuring a Network Connection for a Non-AIX Environment

This configuration method does not require the host to have bootpd or x_st_mgrd running. NFS and/or TFTP will be used in order to establish network connection between the Xstation and host. Verify that TFTP and NFS are running on the host, and that /usr/lib/X11 is in the NFS exports file. In this example, XDM is also used to manage the Xstation, therefore verify that XDM is running on the host.

At the Main Menu select **Xstation Configuration**, then select **Network Parameters**. Modify the parameters of the menu to look like the following example:

```

Network Parameters

Ethernet Adapter          XXXXXXXXXXXX
Protocol                  Automatic  Ethernet  IEEE 802.3
Alternate Hardware Address 
BOOT                     Broadcast (default)  Direct  Disable
Boot Preference          Base FLASH  TFTP  Optional FLASH
Terminal Internet Address  XXX.XXX.XXX.XXX
Host Internet Address    XXX.XXX.XXX.XXX
Gateway Internet Address  XXX.XXX.XXX.XXX
Subnet Mask              XXX.XXX.XXX.XXX
XDMCP Query Type       Direct 
XDMCP Internet Address  XXX.XXX.XXX.XXX
Automatic update of FLASH  Enable  Disable  On Next Reboot
Default Telnet Host     XXX.XXX.XXX.XXX
Boot File Name          /etc/x_st_mgr/X140serv
Slip Terminal Internet Address
Slip Remote Host Internet Address
Slip Subnet Mask
Slip Dial String

Esc
Xstation Configuration Serial Port Help

```

Return to Xstation Configuration, then select **File Servers**. Modify the parameters of the menu to be like the following example:

The screenshot shows a terminal window titled "File Servers". It is divided into two sections: "Primary File Server: NFS" and "Secondary File Server: TFTP". Each section has three fields: "Host Internet Address", "Port", and "Default Path". The "Host Internet Address" field contains "XXX.XXX.XXX.XXX", the "Port" field is empty, and the "Default Path" field contains "/usr/lib/X11/". There are "List" buttons next to the "Host Internet Address" fields. At the bottom of the window, there is an "Esc" key indicator, a highlighted "Xstation Configuration" button, and a "Help" button.

Return to Xstation Configuration, then Main Menu. Select **Save Changes** and then select **Reboot**.

Remote Configuration

The previous four examples show various ways to configure your Xstation locally. Other terminal configuration values can be set using the local graphical menus, such as panning, backingstore and I/O devices.

Remote configuration is another useful configuration method. The initialization software (IPL) executes after the Xstation is turned on and during IPL the remote configuration file is read and applied to the workstation. The remote configuration file resides on the Xstation's boot host in `/etc/x_st_mgr/xs140/cfg/x.x.x.x` where `x.x.x.x` is the Internet protocol (IP) address for the Xstation in dotted-decimal format.

Precedence and File Content

The values in the remote configuration file take precedence over any configuration that is present at the time that you start up your workstation. If the local menus are displayed, the values from the remote configuration file are shown. If you selected **Save Changes**, the values in the remote configuration file are written to NVRAM, thus taking precedence over the previously saved local configuration.

The remote configuration file consists of comments and name/value assignment entries. Comment lines begin with a pound sign (#) and are terminated with a new-line character. A sample configuration file can be found in the `/etc/x_st_mgr/xs140/cfg` directory.

The remote configuration file is created when SMIT is used to configure an Xstation 150 or 140. Additional values that SMIT does not configure, such as `rgb_database`, can be added manually.

Example 5. Updating FLASH from the Network

One way to update FLASH is to transfer the files over the network. Verify that the update files are located on the host. The default directory is `/etc/x_st_mgr/xs140/upd`. At the Main Menu, select **Xstation Configuration**, then **Network Parameters**. On your existing menu, select **BOOTP – Disable**, then fill in the appropriate Internet addresses (you will have to do this if you have previously used **BOOTP – Broadcast**), verify that the **Boot File Name** is `/etc/x_st_mgr/X140serv` and select **Automatic update of FLASH – On Next Reboot**.

Network Parameters

Ethernet Adapter Protocol Automatic Ethernet IEEE 802.3

Alternate Hardware Address

BOOTP Broadcast (default) Direct Disable

Boot Preference Base FLASH TFTP Optional FLASH

Terminal Internet Address

Host Internet Address

Gateway Internet Address

Subnet Mask

XDMCP Query Type Direct

XDMCP Internet Address

Automatic update of FLASH Enable Disable On Next Reboot

Default Telnet Host

Boot File Name

Slip Terminal Internet Address

Slip Remote Host Internet Address

Slip Subnet Mask

Slip Dial String

Esc

Return to Xstation Configuration, then Main Menu. Select **Save Changes** and then select **Reboot**.

If you select **Automatic update of FLASH – Enable**, the system will compare the dates of the files resident in FLASH memory and the date of the bootfile that you have chosen to use for the update process. If the data in the bootfile is more recent than the file in the Xstation's FLASH memory, the FLASH memory will be updated. If the file is older, FLASH memory will not be updated.

Selecting **Automatic update of FLASH – On Next Reboot** forces the Xstation to replace the server code in FLASH memory with the host bootfile regardless of the version.

Step 4. Choose Terminal Mode

Your Xstation can operate in three modes: as an X-Windows terminal, as a telnet terminal, or as an asynchronous terminal.

X-Windows Mode

Your Xstation operates in X-Windows mode by default. You can operate your Xstation in telnet or asynchronous mode by selecting one of these modes from the Xstation Main Menu.

Telnet Terminal Mode

To operate your Xstation in telnet terminal mode, perform the following steps.

1. If you don't already have the Xstation Main Menu displayed and are in an X-Windows session, press the Alt and Print Screen (SysRq) keys at the same time
2. Move the pointer to the top portion of the Main Menu and click on the button to the left of **Telnet Terminal**.

Note: While you are using the Xstation as a telnet terminal you cannot use it as an X-Windows terminal. To switch back to X-Windows mode, click on the **Main Menu** button, then click on the button to the left of **X-Windows**.

Telnet Terminal Emulator
(vt100)

Enter Internet Address (Default is XXX.XXX.XXX.XXX):

Main Menu **Disconnect** **Reset Emulator** **Help**

3. If your Xstation doesn't immediately begin to operate in telnet mode, do the following:
 - a. Ensure that your TCP/IP cable is connected properly.
 - b. Ensure that the cable is connected to the selected TCP/IP port and that the Internet address at the top of the screen is correct. To change the Internet address, type in a new address after the colon and press Enter.
 - c. If the problem persists, go to "Recommended Action 1" on page 5-5.

Asynchronous Terminal Mode

To operate your Xstation as an asynchronous terminal, perform the following steps.

1. If you don't already have the Xstation Main Menu displayed and you are in an X-Windows session, press the Alt and Print Screen (SysRq) keys at the same time.
2. Move the pointer to the top part of the Main Menu and click on the button to the left of **Asynchronous Terminal**.

Note: While you are using the Xstation as an asynchronous terminal you cannot use it as an X-Windows terminal. To switch back to X-Windows mode, click on the **Main Menu** button, then click on the button to the left of **X-Windows**.

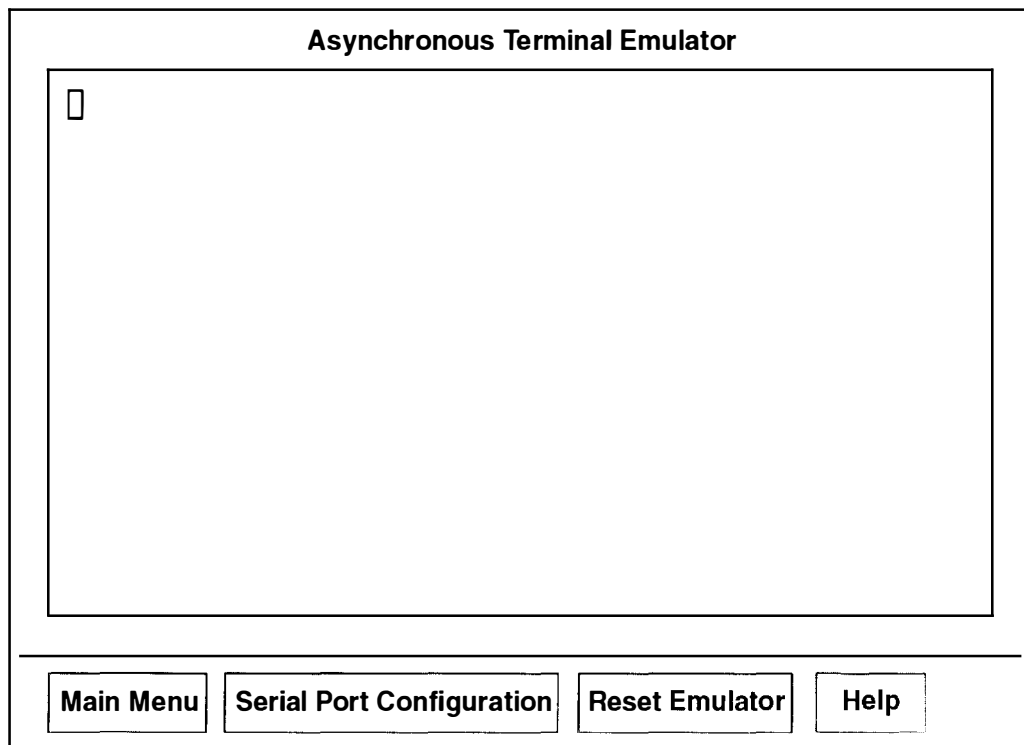

3. Click on the **Serial Port Configuration** button to set up the serial port for your application. Select **Asynchronous Terminal**. Asynchronous terminal emulation can only be configured on the serial port (S1).

If you are using the Xstation as a console for the host, perform the following steps:

- a. Use the serial port parameters listed here:

Serial Port	S1
Data Bits	8
Stop Bits	1
Parity	None
Flow Control	Xon/Xoff
BAUD Rate	9600

Note: Set the BAUD rate to the same value as the rate on the host port to which you connect.

- b. Connect the Xstation to the host with an RS-232 terminal cable such as Option Number 6298186, Part Number 6298526.
4. To return to the Asynchronous Terminal Emulation, click on the **Asynchronous Terminal** button in the Serial Port Configuration menu.
5. Set the **TERM** environment variable using the following commands:

```
TERM = vt100
export TERM
```
6. If your Xstation doesn't immediately begin to operate in asynchronous mode, ensure that the configured serial port is connected properly to a functional device that matches the configuration of the serial port (S1).

If your Xstation still does not respond, proceed to Chapter 5, "Problem Determination Procedures."

Chapter 4. Keyboard and Mouse Operation

Using the Keyboard

There are several keyboards available with the Xstation. Keyboards can be engraved with the alphabets of different countries, and the functions of each key depend on the software used.

Note: Your keyboard configuration may vary from the following illustration.

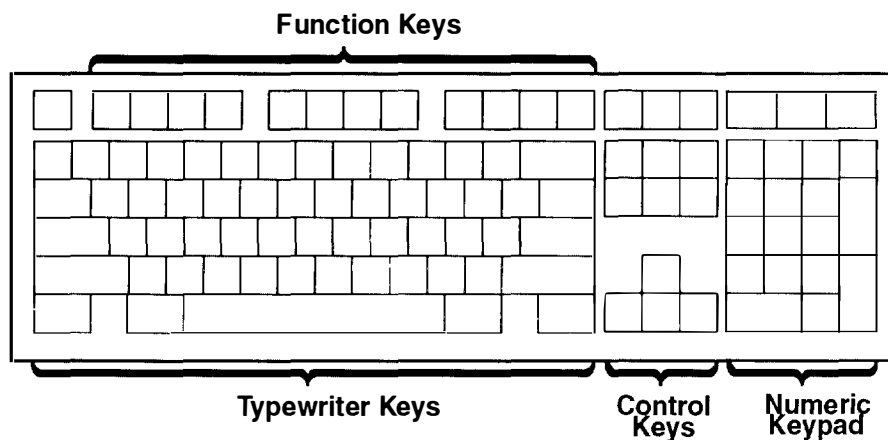

The keyboard is divided into four sections:

- The function keys are multipurpose keys whose functions are controlled by the operating system.
- The typewriter keys are similar to a standard typewriter. Their function is controlled by the software.
- The control keys move the cursor on the screen and perform programmed control functions. The movement and functions depend upon the application used.
- The numeric keypad is arranged like a calculator to help when typing numbers. These keys are active when Num Lock is activated.

To tilt the keyboard for typing comfort, pull out on the keyboard legs. The legs will snap out into position.

To decrease the tilt of the keyboard, rotate the keyboard legs until they snap into the bottom of the keyboard case.

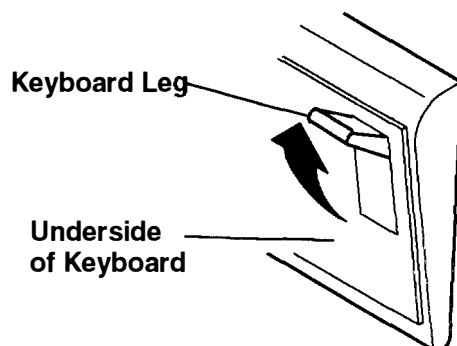

Using the Mouse

The three-button mouse shown is a hand-operated locator device available for use with the Xstation; consult your application publication for exact use of the mouse.

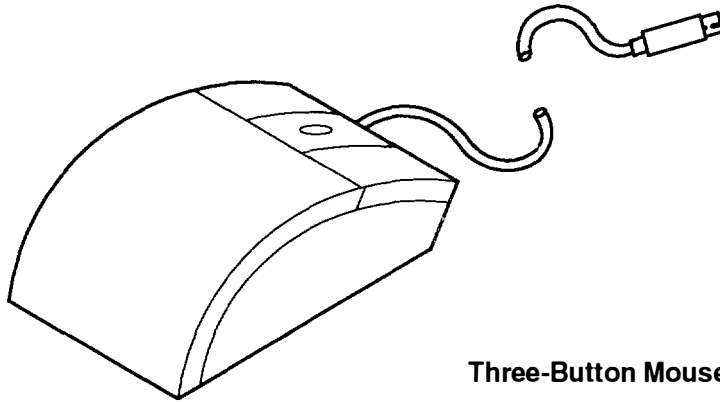

Three-Button Mouse

You can use the mouse to perform such functions as positioning a cursor, selecting items from a menu, or moving around in your document more easily and quickly than with the keyboard. You can also use the mouse for graphics applications if the software is so equipped.

When you move the mouse around on a flat surface as shown in this illustration, the pointer moves on the display screen; the movement positions the pointer.

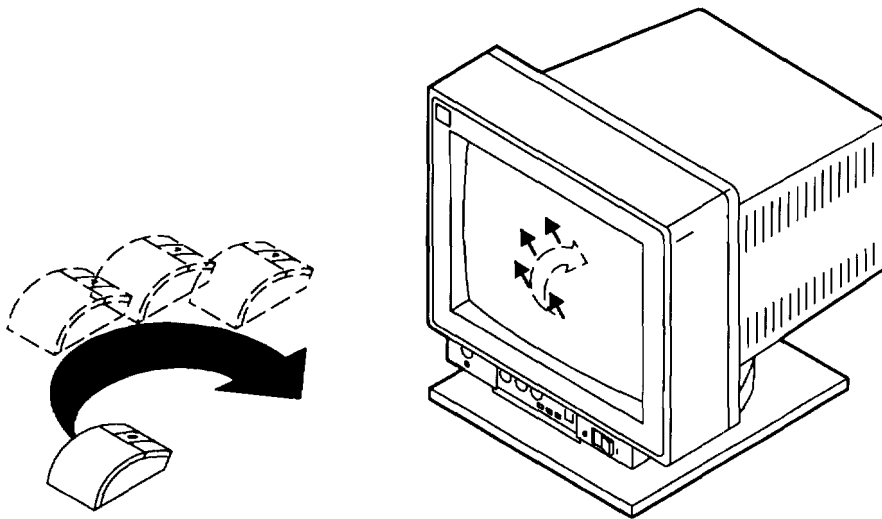

With the mouse buttons, you can perform functions such as selecting and deselecting options, extending your selection, or choosing a command. The function of your mouse depends on the software you are using.

The mouse cable plugs into a mouse connector on the back of the Xstation.

Handling the Mouse Correctly

For best operation, handle the mouse correctly. Incorrect handling can damage the mouse.

Do not:

- Operate the mouse on cloth, unfinished wood, newspaper, or carpet.
- Drop or hit the mouse.
- Pull the cable. You can cause damage to the cable and the connector.
- Carry the mouse by holding onto the cable.
- Expose the mouse to extreme temperatures or direct sunlight.
- Place the mouse in liquid spills.

Care of the Mouse

The operating surface for the mouse should be smooth, clean, and flat. For example, you can operate the mouse on the following surfaces:

- Finished wood
- Glass
- Enamel
- Plastic (including laminates)
- Paper (except newspaper)
- Metal.

Rough surfaces collect contaminants that can be transferred to the interior of the mouse by the ball. The surface you use should be free from spills, dirt, dust, lint, wax, eraser dust, and other debris. Rough surfaces can also cause the pads located on the bottom of the mouse to prematurely wear. A deeply pitted surface can cause erratic operation of the mouse.

- Inspect the work surface for spills or other contaminants.
- Clean the work surface.
- If you are using a paper pad, inspect it for wear and replace it if necessary.

Cleaning the Mouse

These steps describe how to clean the mouse:

1. Remove the retaining ring by turning the retaining ring counterclockwise, in the direction of the arrow.

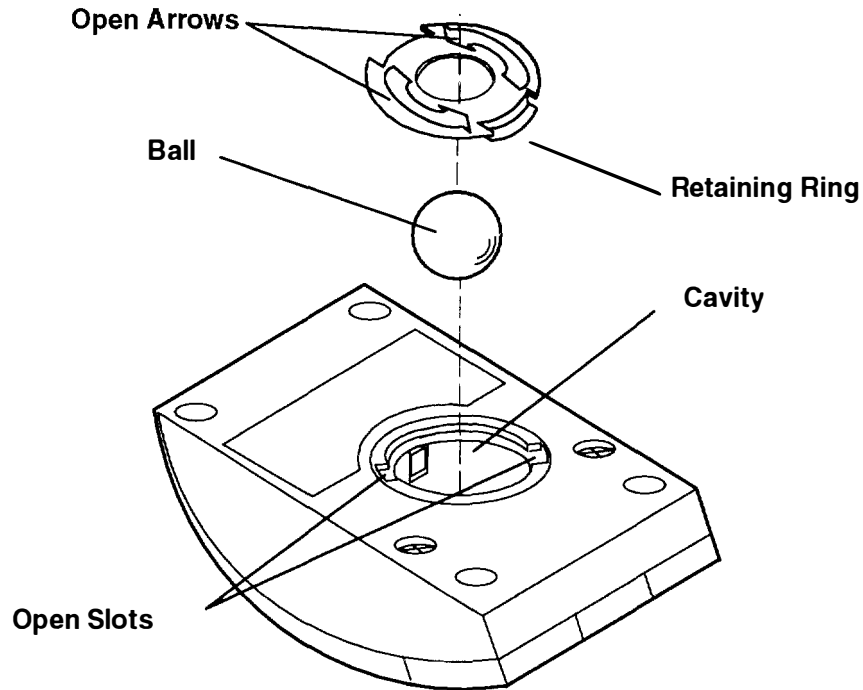

2. Remove the ball.
3. Inspect the ball for contaminants. Wipe it clean with a dry, lint-free cloth.
4. If the ball is dirty, wash it in warm, soapy water. Rinse and wipe the ball with a lint-free cloth until dry.
5. Inspect the ball cavity in the mouse for foreign materials. If there are any foreign materials, remove them.
6. Replace the ball.
7. Replace the retaining ring on the mouse and align it with the open slots in the ball cavity.
8. Turn the retaining ring clockwise until the open slots are covered and you hear the ring snap into place.

Chapter 5. Problem Determination Procedures

The problem determination procedures (PDPs) assist the user in isolating solid failure problems such as no power or a displayed error code.

If you are logged on to the host system, record all of the information that identifies the problem, log off the system (hold down the Ctrl and Alt keys and then press Backspace) and turn the Xstation power off when the Reboot message appears.

Find the symptom in the following table that best describes the problem and take the indicated action. If the problem persists, record all of the information that identifies the problem and go to the appropriate "Recommended Action" (RA) on page 5-5.

Symptom	Action	RA
Power Problem <ul style="list-style-type: none"> • The power-on light does not come on, or comes on but does not stay on. • The fan is not running. • The display remains blank with no audible beep. • The keyboard LEDs do not flash. 	Check that the Xstation power cable is plugged into the Xstation and to an outlet that has proper power.	1
Error Code Displayed The Xstation stops with one or more error codes displayed on the POST and LAN Statistics Screen and two short beeps may sound.	Proceed to "Error Analysis" on page 5-2.	–
Display Problem <ul style="list-style-type: none"> • The Xstation beeps once or twice, and the display remains blank, unreadable, rolling, out of focus, and so forth. • One long and two short beeps sound, indicating that the monitor type was not recognized and defaulted to the 6091 type. • The characters on the screen are the wrong size. • The colors displayed are not normal. 	Check the following: <ol style="list-style-type: none"> 1. The display jumpers and display mode switch settings are as shown on page 2-10. 2. The display power cable is plugged into the display and to an outlet that has proper power. 3. The display signal cable is not damaged and properly attached as shown on page 1-7. 4. The display power switch was in the On position and the display controls are adjusted. 	1

Symptom	Action	RA
Other Hardware Problems <ul style="list-style-type: none"> No beep sounds Any other combination of beeps other than the normal one short beep. Four minutes have elapsed and the LAN Communications have stopped. Any other hardware problem. 	Check all the cables to assure they are securely attached and not damaged. For more problem diagnoses, go to the Xstation Main Menu. If successful, click on Statistics and Logs , then view the area of concern.	1
Software Problems <ul style="list-style-type: none"> Stops with any LAN communicated text, "Cannot load configuration file," or "Server Halted," for example. The POST and LAN statistics screen appeared, but the login screen fails. An intermittent problem occurs on one application or command only. 	If the 0000 code appears in the ipl completion code field (page 3-1) on the LAN Statistics Screen, you can assume that the hardware is functional. Assure that you have sufficient memory for your application. For more problem diagnoses, press the Esc key to display the Xstation Main Menu. If successful, click on Statistics and Logs , then view the area of concern.	2

Error Analysis

If the fan is not running, refer to "Recommended Action" number 1 on page 5-5. If a problem is detected during the Power-On Self-Test (POST), the normal audio beep may not be heard and the following screen will appear:

POST Checkpoint

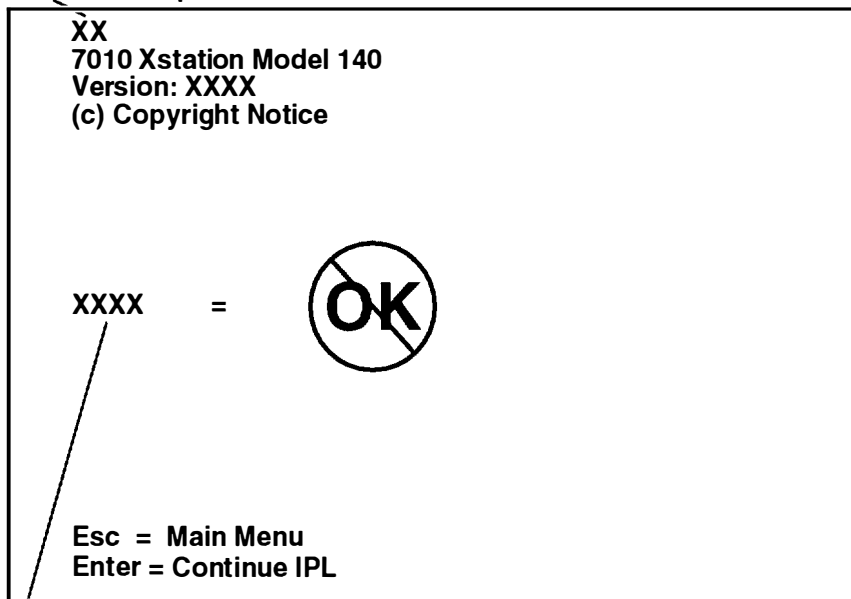

Error Code

POST and LAN Statistics Screen

If more than one error code is displayed, refer to the nonconfiguration error codes in the order displayed.

If a configuration error code numbered 160 through 179 occurs, then the configuration of the Xstation will be automatically updated during the next POST.

If you have not recently changed your Xstation configuration, find the error code in the following table and take the indicated action. If the problem persists, record all of the information that identifies the problem and refer to "Recommended Action" number 1 on page 5-5.

All POST error codes are kept in a log and can be viewed by doing the following:

1. While the POST and LAN Statistics screen is displayed, press the Esc key to view the Xstation Main Menu.
2. Click on the **Statistics and Logs** button, then click on the **Power On Self Test (POST)** button to view the POST logs.
3. Click on the **Main Menu** button, then click on the **Startup Messages** button to view the startup messages.

Configuration Error Codes

Error Code	Configuration Change	Action	RA
161, 169	Display	Check for damaged or unplugged display cables.	1
162	Non-volatile RAM (NVRAM) checksum	Turn Xstation off, then turn back on to recalculate checksum.	1
163, 167	File System	Reboot the Xstation.	1
164	DRAM (SIMMs)	Remove and reinstall SIMMs.	1
168	Optional FLASH card	Remove and reinstall FLASH memory card.	1
170	Mouse	Replug the mouse cable.	1
171	Keyboard	Replug the keyboard cable.	1
172	Serial Port	Replug the attached device.	1

Nonconfiguration Error Codes

Find the nonconfiguration error code in the following table and take the indicated action. If the problem persists, record all of the information that identifies the problem and refer to the "Recommended Action" (RA) on page 5-5.

Error Code	Possible Areas of Failure	RA
None	All appears normal.	—
10x, 11x	Detected system board error.	1
2xx	System board memory error.	1
302, 304	Keyboard stuck key or the same as 3xx.	1
3xx	Keyboard, keyboard cable, or system board error.	1
4xx	Parallel port error.	1
5xx	System Board FLASH memory error, FLASH file system.	1
8xx	Optional FLASH card error, FLASH file system.	1
910	DRAM SIMM configuration. The SIMM in slot J43 must have the same amount or more memory capacity than the SIMM in slot J42. If only one SIMM is installed, it must be placed in J43.	1
9x1	DRAM error (J43).	1
9x2	DRAM error (J42).	1
11x1, 80x1	Serial port S1 error.	1
11x2, 80x2	Serial port S2 error.	1

Error Code	Possible Areas of Failure	RA
24xx	System Board (DAC), display cable, or display error.	1
66xx, 77xx, 88xx	See LAN error analysis on page 5-4.	–
86xx	Mouse or system board error.	1
Any other code	Undetermined error.	1

Note: The “x” stands for numbers 0 through 9. A number 0 in the last position indicates no error exists; numbers 1 through 9 indicate an error is present.

LAN Error Analysis

LAN extended error codes and error counts are used for detailed analysis of communications problems. A log of LAN error codes can be displayed by entering the Main Menu, clicking on the **Statistics And Logs** button, then clicking on the button next to the log or statistics list you want displayed.

Network Error Codes

Ensure that the LAN communication cables are not damaged and are properly connected. Record the problem identified and refer to the “Recommended Action” (RA) on page 5-5.

Code	Explanation	RA
66xx	Refers to the Token-Ring network.	
77xx	Refers to the SLIP network.	
88xx	Refers to the Ethernet network.	
Where “xx” is one of the numbers below:		
01	Internal error.	1
02	External wrap error, assure that the external wrap connector is properly installed.	1
03	Normal for Ethernet “Thick” networks in which SQE is disabled; otherwise treat this error the same as an --02.	–
10	After three retries, TFTP error packet still received from host.	2
20	Invalid network setup.	2
21	The bootfile (file specified in the returned Ethernet BOOTP record) is not the correct format.	2
22	Error detected in the bootfile size.	2
23	Error detected in determining the internal header of the Ethernet bootfile.	2
24	TFTP error (after 5 attempts).	2
25	Undefined Ethernet communication error (after 5 attempts).	2

Other LAN Error Codes (6602 07XX)

Extended Token-Ring error codes appear next to the communications error code.

These codes indicate an open failure, suspect the Token-Ring adapter configuration, cabling, network, or software problems. Record the problem identified in the table and refer to the “Recommended Action” (RA) on page 5-5.

Code	Explanation for Error Code 6602 07XX	RA
6602 0711	Token-Ring lobe media, function error. This may be caused by the Token-Ring device cable being disconnected from the Token-Ring adapter.	1
6602 0727	Token-Ring physical insertion, ring beaconing.	1
6602 072D	No Token-Ring monitor detected (wrap connector installed). This may be caused by the multiple access unit (MAU) connector on the Token-Ring device cable being unplugged from the Token-Ring network.	1

Note: For error codes not listed above, use the first recommended action which follows:

Recommended Action

- 1 The symptoms indicate a hardware problem with your Xstation. If the symptoms indicate an external device and you have another device of the same type, try using the other device.

If the problem persists, follow your local procedure for requesting hardware service. Report the error code displayed or other symptoms. If a display problem exists, report the display type.

- 2 The symptoms point to a problem outside your Xstation. Possible problem areas include communications, host error, Xstation network setup, configuration error, or software. Consult the "Problem Solving" section of the *Xstation Manager/6000 Version 1.4.1 System Management Guide* and contact your local network or system administrator to resolve your problem.

Part 2. Service

Note: The information in this part is intended only for trained service personnel.

Chapter 6. Reference Information

Xstation Locations

Use the following views of the Xstation to locate switches, connectors, and system board components.

Front View with Cover

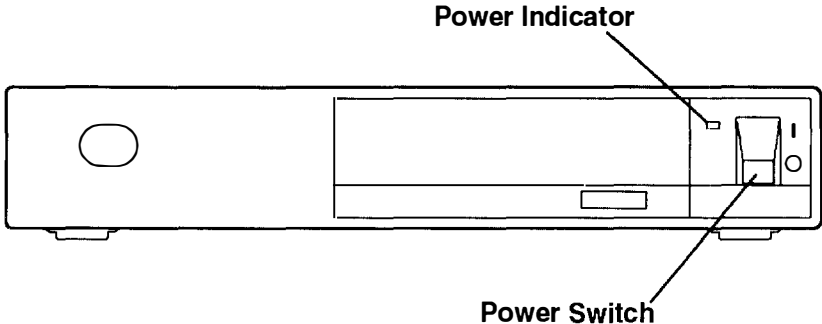

Side View with Cover

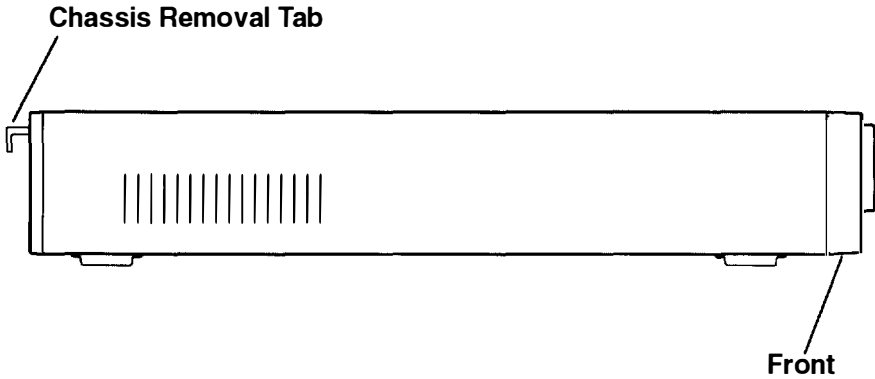

Rear View with Cover

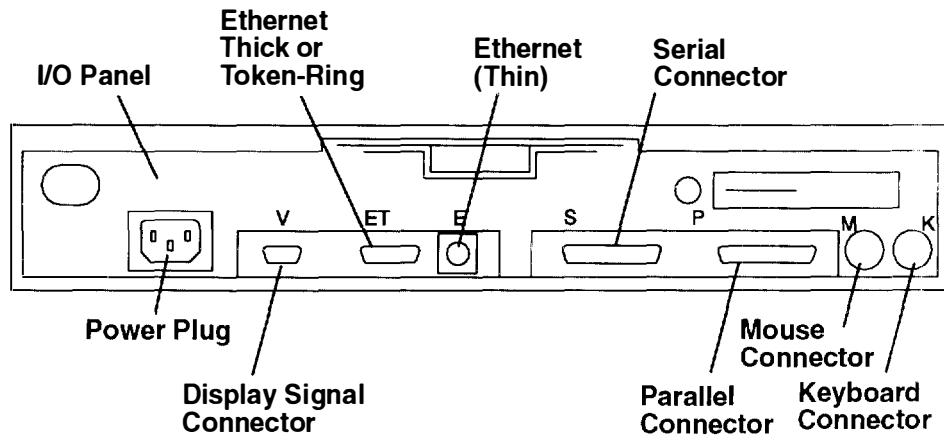

System Board

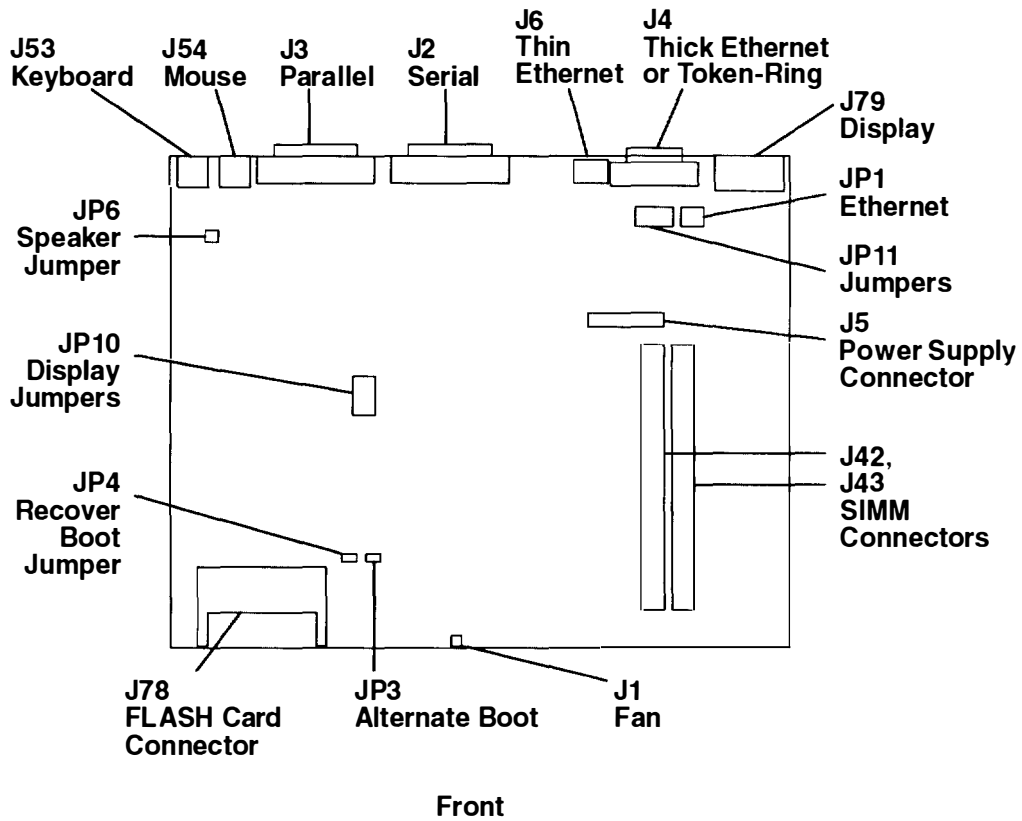

Maintenance Package

Xstation Model 140 built-in diagnostics can be supplemented by a Maintenance Package, Part Number 43G2859, which includes:

- This *7010 Xstation Model 140 Setup, Operator, and Service Guide*
- A serial port wrap plug, Part Number 6298964
- A parallel port wrap plug, Part Number 71F0690
- An Ethernet thick wrap plug, Part Number 71F1167
- An Ethernet thin wrap plug, Part Number 71F1168.
- A system jumper, Part Number 1675209.

Tools

Tools required are:

- Medium, flat-blade screwdriver
- A 3/16 inch thin-wall nut driver
- Wrap plugs (included with the Maintenance Package)
- An analog multimeter or equivalent.

Specifications

Dimensions

- Height 72 mm (2.9 in.)
- Width 375 mm (14.8 in.)
- Depth 380 mm (15 in.)

Weight

7.5 Kg (16.5 lbs)

Note: Configuration dependent.

Operating Environment

Operating Temperature 16° to 32°C (60° to 90° F)

Non-Operating Temperature 10° to 43°C (50° to 110° F)

Relative humidity (noncondensing)

Operating 8 to 80%

Non-operating 8 to 80%

Noise Emissions Values

$L_{WA,d}$	Operating (bels)	4.7
	Idle (bels)	4.7
$L_{pA,m}$	Operating (dBA)	33
	Idle (dBA)	33
$\langle L_{pA} \rangle_m$	Operating (dBA)	31
	Idle (dBA)	31
Impulsive Noise		No
Prominent Discreet Tones		No

Power Source

0.09 k VA (maximum)

Source Voltage and Frequency

100 to 125 V ac; 48 to 62 Hz

200 to 240 V ac; 48 to 62 Hz

Thermal Output

317 BTU/hr (maximum)

Power Consumption

65 Watts

Service Inspection Guide

The intent of this inspection guide is to assist you in identifying potentially unsafe conditions while servicing the Xstation. Each machine, as it was designed and built, had required safety items installed to protect users and service personnel from injury. This guide addresses only those items. However, good judgement should be used to identify potential safety hazards due to the attachment of features or options not covered here.

If any unsafe conditions are present, the severity of the apparent hazard must be determined as well as whether you can continue without first correcting the problem.

Consider the following conditions and the safety hazards they present:

- Electrical hazards, especially primary power. Primary voltage on the frame can cause serious or fatal electrical shock.
- Explosive hazards such as a damaged CRT face or bulging capacitors can cause serious injury.
- Mechanical hazards such as loose or missing hardware can cause serious injury.

Service Inspection Checklist

Perform a service inspection on the system when:

- The system is inspected for a maintenance agreement.
- Service is requested and service has not recently been performed.
- An alterations and attachments review is performed.
- Changes have been made to the equipment that may affect the safe operation of the equipment.

If the inspection indicates an unacceptable safety condition, the condition must be corrected before servicing the machine.

Note: The correction of any unsafe condition is the responsibility of the owner of the system.

This guide consists of a series of steps presented in a checklist. Begin the checks with the power off and the power cord removed from the power receptacle.

Do the following:

1. Check the covers for sharp edges and for damage or alterations that expose the internal parts of the Xstation.
2. Check the covers for proper fit to the Xstation. They should be in place and secure.
3. If installed in a vertical stand, remove the Xstation from the stand and place in a horizontal position.
4. Remove the covers.
5. Check for any non-supplier alterations. Use good judgment as to the safety of non-supplier alterations.
6. Check inside the unit for obvious unsafe conditions such as metal filings, contamination, water or other liquids, or signs of fire or smoke damage.
7. Check the internal cables for damage.

8. Check the voltage label on the back of the Xstation to ensure that it matches the voltage at the outlet.
9. Check that the power supply cover fasteners (screws or rivets) have not been removed or tampered with.
10. Check for the following label on the power supply:

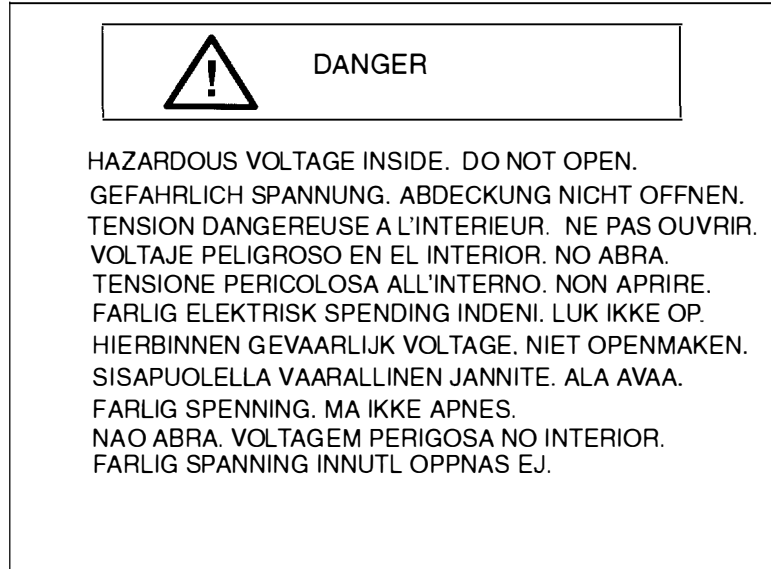

11. If applicable, check that the proper power supply fuse is installed.
Note: The fuse may be located on the system board rather in the power supply. In addition, the fuse may be factory-replaceable only.
12. Check the external power cable for damage.
13. With the external power cable connected to the system unit, check for 0.1 ohm or less resistance between the ground lug on the external power cable plug and one of the jack screws on the parallel connector.
14. If the Xstation passes the test in the previous step, install the covers.

Chapter 7. MAPs

Start of Call

Start all problem isolation with the “MAP 0010: Start MAPs” Then carefully follow the steps to isolate the failure to a Field Replaceable Unit (FRU).

The Xstation uses built-in tests, together with available wrap plugs.

Refer to the *Xstation Manager/6000 Version 1.4.1 System Management Guide*, Form Number SC23-2264, for additional information on software problems.

MAP 0010: Start MAPs

The Start MAP guides the trained service person in isolating all Xstation hardware problems.

MAP 0020: Power

The Power MAP assists the trained service person in isolating the FRU. All external devices are removed and the Xstation configuration is set to minimum. The remaining hardware is tested and exchanged until the FRU is isolated.

MAP 0030: Displays

The Display MAP guides the trained service person in solving display-associated problems.

MAP 0040: Diagnostics

The Xstation's Power-On Self-Test (POST) provides the first layer of diagnosis of specific problems. Further diagnostics (described in this MAP) should be consulted for additional isolation of problems.

MAP 0010: Start Maps

Purpose of This MAP

The Start MAP guides the trained service person in isolating all Xstation hardware problems.

Step 1. Power Off

Check that the Xstation is turned on.

Is the machine logged on to the host system?

NO Do the following:

1. Turn off the Xstation power.
2. Go to Step 2.

YES Do the following:

1. Log off the host system (hold down the Ctrl and Alt keys, then press the Backspace key). If necessary, get customer's help
 2. When the Reboot message is displayed, turn off the Xstation power
 3. Go to Step 2.
-

Step 2. Analysis

(From Step 1)

1. Discuss and record the failure symptom with the customer.
2. Check all external cables and connectors.
3. Open the chassis as instructed in "Chassis Assembly" on page 8-3 and visually inspect the Xstation components. Record and verify the jumper settings and hardware options installed in order to verify POST and software-detected configuration.
4. Check the power outlet for proper power and grounds.

Is there an obvious problem such as broken, loose, or overheated components?

NO Go to Step 3.

YES Do the following:

1. Correct the problem and assure that the fan runs when power is turned on.
2. If the problem persists, turn the Xstation power off and go to Step 3

Step 3. Assess Situation

(From Step 2)

1. Turn on the Xstation power.
2. Listen carefully for any audio signals during the Power-On Self-Test (POST); one short audio beep is normal. Verify that the fan is running.
3. Starting at the top of the following table, find the symptom that best describes the problem and take the action indicated. Running diagnostics may help to isolate the FRU; go to "MAP 0040: Diagnostics." If the problem persists, go to "MAP 0020: Power" to chronologically isolate the FRU.
4. All menu selections indicated in the following table are made from the Xstation's Main Menu. To display the Main Menu, press Esc while the POST and LAN Statistics screen is displayed, or press the Alt and Print Screen (SysRq) keys together while in an X-Windows session.

Symptom	Action
Main Power –Power-on light does not come on, or comes on but does not stay on.	Go to "MAP 0020: Power." Probable failure: (1) power cord, (2) power supply.
Fan –The fan is not running. This can cause heat build-up, resulting in intermittent problems.	Replace fan and assure new fan rotates freely.
Power –The power light is on, the display remains blank, and no beep is heard, or the keyboard LEDs fail to flash on and off.	Go to "MAP 0020: Power." Probable failure: (1) system board, (2) jumpers, (3) power supply. see also "Keyboard" below.
Error Code –The Xstation stops with one or more error codes visible on the screen. –Two short beeps indicate that a POST error was detected.	Go to Step 4 (Error Code Analysis). The POST error log can be viewed in the Statistics and Logs menu selected from the Main Menu screen. If the screen is unreadable, go to "MAP 0020: Power."
Display –The display remains blank, unreadable, rolling, out of focus, and the Xstation may sound one or two short beeps. –The characters on the screen are the wrong size. –Missing or additional lines, colors, bars, etc. –The colors/shades displayed are not normal. –One long and two short beeps indicate a probable unsupported display configuration.	Adjust the controls on the display (contrast, brightness). If two short beeps sounded, go to "MAP 0020: Power." If problem remains, go to "MAP 0030: Display." Probable failure: (1) display, (2) cable, (3) jumpers (4) system board, (5) DRAM (SIMMs).
Keyboard –No beep is heard and normal LAN Communication is established. The system board failed to produce the sound in the keyboard. –Repeating characters displayed on the screen indicate a stuck key on the keyboard. –Keyboard LEDs fail to flash on and off. –Keyboard LEDs flash on and off repeatedly.	Probable failure: (1) keyboard, (2) keyboard cable, (3) system board. Ensure that the keyboard cable is connected to the K connector. Check for dirt, dust, or other matter in and around the keyboard. Check for stuck keys. If problem persists, go to "MAP 0020: Power."
Continue with table on the following page.	

Symptom	Action
<p>Other Sounds –Any other combination of beeps or a continuous sound is heard. –No sound is heard.</p>	<p>Go to “MAP 0020: Power.” Probable failure: (1) speaker jumper, (2) keyboard, (3) system board, (4) fan, (5) power supply.</p>
<p>LAN Text –The Xstation stops with the LAN text message “Cannot load X server code” or “Server Halted.”</p>	<p>Suspect insufficient memory (DRAM SIMMs or FLASH) or network communication. Go to “MAP 0020: Power.” Probable failure: (1) DRAM SIMMs, (2) FLASH card, (3) system board. If problem persists, go to Step 7 (Communication Network).</p>
<p>LAN –Stops with any other LAN text message. –An error code is displayed on the POST and LAN Statistics Screen or the POST and LAN Statistics Screen is displayed longer than ten minutes.</p>	<p>Select Statistics and Logs and view the appropriate network statistics and error logs. Go to Step 6 (LAN Communication). If failure persists, go to “MAP 0020: Power.”</p>
<p>I/O Device –Normal power on; could not duplicate customer symptom, or there seems to be a serial/parallel I/O problem.</p>	<p>Go to “MAP 0040: Diagnostics.” Select Xstation Configuration and verify the Xstation configuration. Select Test the Terminal and Run All Tests. If the problem is associated with an external device and the diagnostic for the external port does not detect a failure, have the external device serviced.</p>

One of three types of network information may be displayed on the LAN Statistics portion of the POST and LAN Statistics Screen: Ethernet, Token-Ring, or SLIP.

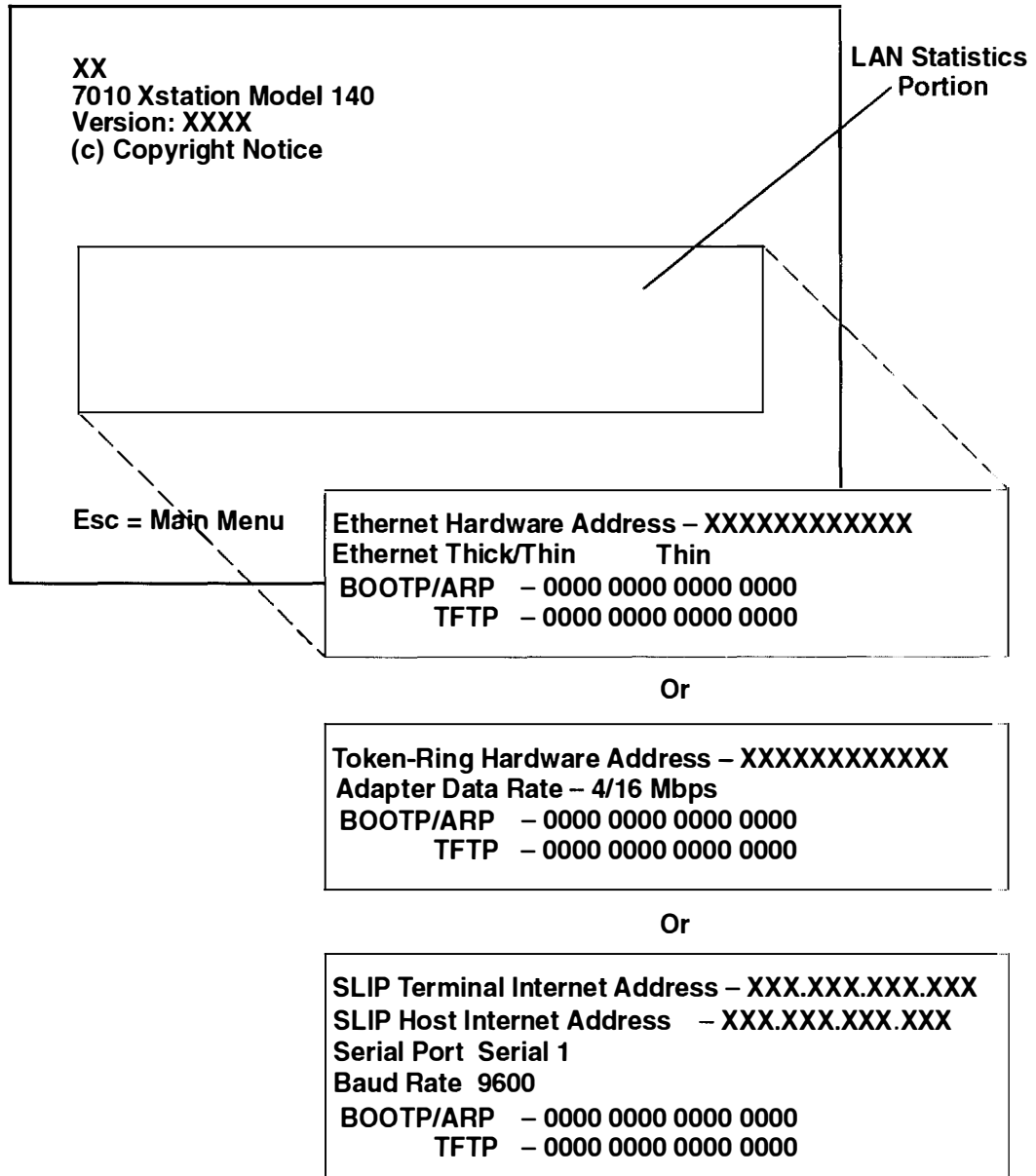

The first four fields for BOOTP/ARP and TFTP are counts of LAN communication conditions. Fields five and six of TFTP are LAN error codes.

- Field 1 Requests sent.
- Field 2 Packets received.
- Field 3 Invalid replies.
- Field 4 Timeouts.

Step 4. Error Code Analysis

(From Step 3)

Under certain circumstances, more than one error code may be displayed; each will be displayed on a separate line.

Before analyzing error codes, verify that the required devices are plugged into the correct ports.

Error codes 160 through 179 are configuration problems and may be caused by other, undetected errors. Work nonconfiguration error codes first and in the order displayed.

Is the only error code displayed 160 through 179?

- NO** Do the following:
1. Work the first error code displayed using the following table.
 2. Go to "MAP 0040: Diagnostics" and use diagnostics to verify the fix.
 3. If the problem persists, go to "MAP 0020: Power" to chronologically isolate the FRU.
- YES** Go to Step 5.

Error Number	Action
10x, 11x, 2xx, 305	Suspect system board; go to "MAP 0020: Power."
302, 304	Run keyboard diagnostics and check for a stuck key. If the problem persists, replace in order: (1) keyboard, (2) keyboard cable (3) system board.
3xx	Verify that the keyboard cable is connected to the K port. Replace in order: (1) keyboard, (2) keyboard cable, (3) system board.
4xx	Run parallel port tests. If no failure is found, replace the attached device; if problem persists go to "MAP 0020: Power."
501	System board FLASH. Suspect system board; go to "MAP 0020: Power."
5xx	System board FLASH files. Suspect system board; go to Step 10.
801	Suspect Optional FLASH card; go to "MAP 0020: Power."
8xx	Suspect Optional FLASH files; go to Step 10.
9xx	Memory problem; go to Step 8.
11xx, 80xx	Serial port problem; go to Step 9.
24xx	Display problem; suspect system board (DAC) or display cable. Go to "MAP 0020: Power."
66xx, 77xx, 88xx	LAN problem; go to Step 6.
86xx	Ensure that the mouse cable is connected to the M port. Refer to pages 4-2 through 4-4 to ensure proper use of the mouse. Replace mouse; if problem persists, go to "MAP 0020: Power."
Any other code	Undetermined error; go to "MAP 0020: Power."

Note: The "x" stands for numbers 0 through 9. A number 0 in the last position indicates no error exists; numbers 1 through 9 indicate an error is present.

Step 5. Configuration Match

(From Step 4)

The physical configuration detected does not match the configuration stored in nonvolatile RAM (NVRAM).

View the POST logs to determine if the Xstation configuration has been recently changed. To view the POST logs, press the Esc key while the POST and LAN Statistics screen is displayed, or press the Alt and Print Screen (SysRq) keys together while in an X-Windows session. When the Main Menu appears, click on the **Statistics and Logs** button, then click on the **Power On Self Test (POST)** button to display the POST log.

Check with the customer to determine the expected configuration and verify that the hardware matches the expected configuration. Verify also that the Xstation detects the expected configuration by displaying the Main Menu and clicking on **Base Configuration**.

1. If the expected configuration, the hardware, and the detected configuration do not match, perform the following:
 - a. Refer to the table on page 7-0010-7 and take the indicated "Action," then go to "MAP 0040: Diagnostics" and test the changed area. If another error is found, work non-configuration codes first by going back to Step 1 on page 7-0010-1.
 - b. If the indicated "Action" fails to identify another cause, exchange the probable failure FRUs identified in the table on page 7-0010-7.
 - c. If the problem persists, Go to "MAP 0020: Power" to isolate the FRU.
2. If the Xstation configuration has been recently changed, turn off and turn on the Xstation. If the configuration error code persists, do the following:
 - a. Exchange the probable failure FRUs identified in the table on page 7-0010-7.
 - b. If the problem persists, go to "MAP 0020: Power" to chronologically isolate the FRU
 - c. If the error code no longer appears, the error is normal and no action is needed

To select the appropriate diagnostic tests, click on **Test The Terminal** from the Xstation's Main Menu. Click on the desired test selection, then proceed with the action listed in the following table.

Error Code	Configuration Change	Action
161, 169	Display	Check for damaged or unplugged display cables. Select the Display option. Go to "MAP 0030: Displays." Probable failure: (1) display, (2) display cable, (3) system board.
162	Non-volatile RAM checksum	Turn off, then turn on Xstation to recalculate the checksum. The user may be required to reconfigure the Xstation. Go to "MAP 0020: Power." Probable failure: system board.
163, 167	Xstation File system (NVRAM, FLASH)	Probable failure: system board The user may be required to reconfigure the Xstation; go to Step 10.
164	Memory	Select the System Board option. Go to "MAP 0020: Power." Probable failure: (1) DRAM SIMMs, (2) system board.
168	Optional FLASH Card	Reinsert card and reboot. Go to "MAP 0020: Power." Probable failure: (1) FLASH card, (2) system board.
170	Mouse	Select Mouse option. Go to "MAP 0020: Power." Probable failure: (1) mouse, (2) system board.
171	Keyboard	Select Keyboard option. Go to "MAP 0020: Power." Probable failure: (1) keyboard, (2) keyboard cable, (3) system board.
172	Serial Ports (S1, S2)	Select Serial Ports/Devices option. Go to "MAP 0020: Power." Probable failure: (1) attached device, (2) device cable, (3) system board.

Note: Refer to Chapter 8, "Removal and Replacement Procedures," for parts removal and replacement instructions.

Step 6. LAN Communication

(From Steps 3 and 4)

The Xstation suspects a LAN communication problem.

1. Ensure that the communication cables are properly connected and not damaged.
2. Perform the following:
 - a. If making an Ethernet connection, verify that the Ethernet jumpers are set properly for use of thick, thin, or twisted-pair connections (see "Configure Ethernet" on page 2-8)
 - b. If making a Token-Ring connection, verify that the data-rate selection matches the network's data rate.
 - c. If using SLIP, verify that the serial port configuration matches the host
3. Take the action listed in following tables.
4. Refer to the *Xstation Manager/6000 Version 1.4.1 System Management Guide* to ensure proper configuration of the hardware address; terminal, host, and gateway internet addresses; and subnet mask both at the Xstation and at the host.

LAN Error Codes

Code	Action/Explanation
6601 (Token-Ring)	Exchange in order and retry the failing procedure: (1) Token-Ring system board, (2) Token-Ring device cable. If problem persists, go to "MAP 0020: Power" to chronologically isolate the FRU.
6602 (Token-Ring)	The Multiple Access Unit (MAU) plug on the Token-Ring device cable is used as the external wrap connector. Disconnect the MAU plug from the Token-Ring network and leave the Token-Ring device cable attached to the Token-Ring connector. Go to "MAP 0040: Diagnostics"; verify the Token-Ring data rate and run the Token-Ring diagnostics. If the problem persists, a hardware failure is suspected. Treat the error the same as 6601. If no error is detected in POST or LAN communications tests, suspect configuration, cabling, network, or software problems. Record the explanation shown in the Token-Ring extended error codes and go to Step 7.
The LAN Error Codes table continues on the next page.	

Code	Action/Explanation
7701 (SLIP)	Go to "MAP 0040: Diagnostics" and test the specific serial port associated with SLIP. If no error is detected in diagnostics, suspect configuration, network, or software problems and go to Step 7.
8801 (Ethernet)	Suspect the Ethernet system board. Go to "MAP 0020: Power" to chronologically isolate the FRU.
8802 (Ethernet)	Go to "MAP 0040: Diagnostics." Test the Ethernet LAN communications using an external wrap plug; if the same problem persists, treat it the same as 8801. If a different error is received, go back to Step 4. If the error only occurs when it is attached to the network, go to Step 7.
8803 (Ethernet)	If the attachment is to an Ethernet thick network in which SQE is disabled, the error is normal and do nothing; otherwise, treat it the same as 8802.

Other LAN Error Codes

Code	Action/Explanation for LAN Communication Code
66xx	Refers to the Token-Ring network.
77xx	Refers to the SLIP network.
88xx	Refers to the Ethernet network.
Where "xx" is one of the numbers below.	
10	After three retries, TFTP error packet is still received from the host.
20	Invalid network setup.
21	The boot file (file specified in the returned BOOTP record) is not the correct format.
22	Error detected in the bootfile size.
23	Error detected in determining the internal header of the bootfile.
24	TFTP error occurred after five attempts.
25	Undefined communication error after five attempts.

Token-Ring Extended Error Codes

Code	Explanation for Token-Ring Error Code
6602 06FF	Open time out.
6602 0601	Invalid command code.
6602 0603	Adapter open; should be closed.
6602 0605	Required parameter(s) not provided.
6602 0630	Inadequate receive buffers for LAN to open.
6602 0632	Invalid NODE_ADDRESS.
6602 0633	Invalid adapter receive buffer length defined.
6602 0634	Invalid adapter transmit buffer length defined.

Code	Explanation for Token-Ring Error Code
6602 0711	Lobe media, function failure. This failure is normal when the Token-Ring device cable is disconnected from the Token-Ring connector.
6602 0726	Physical insertion, ring failure.
6602 0727	Physical insertion, ring beaconing.
6602 072A	Physical insertion, ring timeout.
6602 072D	No monitor detected (wrap connector installed). This is normal with the Token-Ring device cable attached to the Xstation, but disconnected from the Token-Ring network. The Multiple Access Unit (MAU) plug on the Token-Ring device cable is the wrap connector.
6602 072E	Monitor contention failed for RPL.
6602 0732	Address verification, signal loss.
6602 0735	Address verification, timeout.
6602 0736	Address verification, ring failure.
6602 0737	Address verification, ring beaconing.
6602 0738	Address verification, duplicate node address.
6602 073A	Address verification, remove received.
6602 0742	Ping poll, signal loss.
6602 0745	Ping poll, timeout.
6602 0746	Ping poll, ring failure.
6602 0747	Ping poll, ring beaconing.
6602 074A	Ping poll, remove received.
6602 0755	Request parameters, timeout.
6602 0756	Request parameters, ring failure.
6602 0757	Request parameters, ring beaconing.
6602 0759	Request parameters, parameters request.
6602 0755	Request parameters, remove received.

Step 7. Communication Network

(From Steps 3, 4 and 6)

Contact communications network support personnel to determine if the network is operational.

Is the network operational?

- NO** Wait until the network is operational, and then retry these procedures starting at "Start of Call."
- YES** Go to "MAP 0040: Diagnostics" and do the following:
1. Select **Statistics and Logs** from the Main Menu.
 2. View the logs from the Statistics and Logs menu.
 3. Select the appropriate network error logs. Communicate the collected symptoms, error counts, and messages to the network support personnel. (Refer to the *Xstation Manager/6000 Version 1.4.1 System Management Guide*.)

Step 8. Memory Isolation

(From Step 4)

The Xstation has a memory problem; use the following procedure to isolate the failure. Refer to the system board location diagram on page 6-2.

Configuration errors (error codes 160 to 179) can occur during this procedure when the configuration is altered.

Error Code	Possible Areas of Failure	Action – proceed in order
910	DRAM SIMM socket J43	3
9x1	DRAM SIMM socket J43	1, 2, 4
9x2	DRAM SIMM socket J42	1, 2, 4
Action		
1. Verify that the SIMMs are compatible with your Xstation.		
2. Change the identified SIMM. If the error no longer occurs, replace the original SIMM		
3. If only one SIMM card is used, it should be inserted in slot 1 (J43). If two SIMM cards are used, the one with more memory should go in slot 1 (J43).		
4. Go to "MAP 0020: Power, Step 3. Voltage Analysis Under Load" on page 7-0020-2.		

Note: The "x" stands for numbers 0 through 9.

Step 9. Serial Port Analysis

(From Step 4)

Serial port tests without the wrap plug are run in POST and can be run from the Test the Terminal menu.

Note: The serial port fan out cable is required for Serial Port 2 (S2) operation and for testing S2 with the wrap plug from the Test the Terminal menu.

Remove all external devices from the serial ports. Go to "MAP 0040: Diagnostics" and test the serial ports S1 and S2 *with* wrap plugs. If an error is detected, follow the associated action as listed in the following table. If no error is detected, suspect the external I/O device

Test each external I/O device, if a test is available. If an error is detected, move the external device to another port (if possible) and retry the failing procedure. If the failure follows the external device, have the device repaired.

If the external device works on another serial port, treat the failure as an error number 11xx, where the last "x" indicates the serial port: 1 = S1 (Serial Port 1) and 2 = S2 (Serial Port 2) Follow the action listed in the following table.

Error Code	Action
11x1, 80x1 (S1)	Remove the serial port fan out cable, if installed, and retry the failing procedure. If the failure persists, suspect the system board and go to "MAP 0020: Power" to chronologically isolate the FRU. If the failure follows the serial port fan out cable, replace the cable.
11x2, 80x2 (S2)	<p>If this error occurs during POST or in a Test the Terminal test without the wrap plug, suspect the system board and go to "MAP 0020: Power" to chronologically isolate the FRU.</p> <p>The serial port fan out cable is required in order to use serial port 2. If this error occurs only with the wrap plug installed, check continuity in the serial port fan out cable using the following table.</p> <p>If the failure persists, suspect the system board and go to "MAP 0020: Power" to chronologically isolate the FRU.</p>

Note: The "x" stands for numbers 0 through 9.

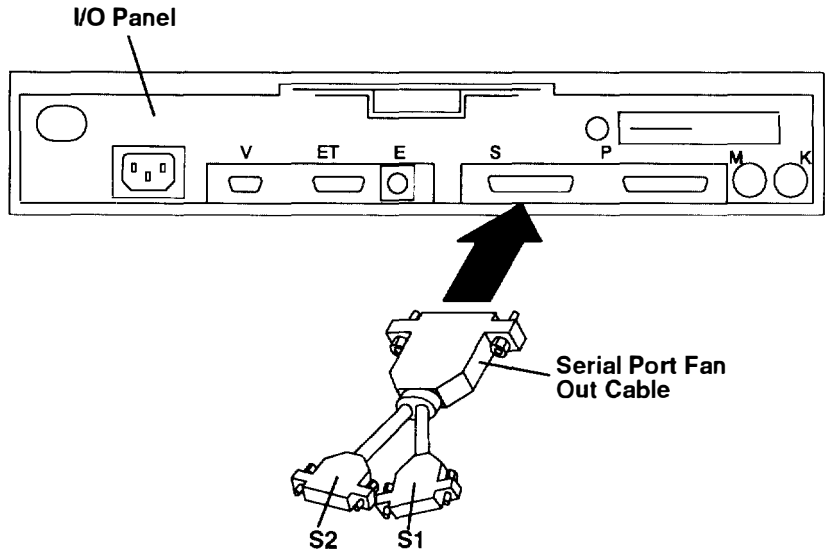

Serial Port 1		Serial Port 2	
I/O Panel S	Fan Out Cable S1	I/O Panel S	Fan Out Cable S2
2	2	14	2
3	3	16	3
4	4	19	4
5	5	13	5
6	6	15	6
7	7	7	7
8	8	12	8
11	11	24	11
20	20	24	20
22	22	17	22

Step 10. FLASH File System

(From Steps 4 and 5)

If you are able to bring up the Xstation's Main Menu, click on **Xstation configuration**, then click on **Network Parameters** and set the Xstation for automatic update of FLASH on the next reboot. Return to the Main Menu and click on **Save Changes**. Reboot the Xstation. If the problem persists, go to "MAP 0020: Power."

A password may be required to change the Xstation's configuration. If so, have the system administrator enter the password or unlock the Xstation in order to reset the password jumpers. (Refer to "Password Reset Jumper" on page 2-12.)

If you are unable to display the Xstation's Main Menu, while the POST and LAN statistics screen is displayed press the Ctrl and Pause (Break) keys. This activates the English-only nongraphical version of the Main Menu. Select **Network Parameters**, then select automatic update of FLASH. Select **On next Reboot**, then **Save Changes**. If the network is not functioning, have the system administrator refer to the *Xstation Manager/6000 Version 1.4.1 System Management Guide* to correct the problem. If the problem persists, go to "MAP 0020: Power."

MAP 0020: Power

Purpose of this MAP

“MAP 0020: Power” assists the trained service person in isolating the failing FRU. All external devices are removed and the Xstation is set to its minimum configuration. Additional configuration errors (error codes 160 to 179) may occur during this process. The remaining hardware is tested and exchanged until the FRU is isolated.

Step 1. Power Cord

If the power-on indicator is lit, go to Step 2. If the power-on indicator is not lit, do the following:

1. Turn off the Xstation and display power.
2. Check the electrical outlet for correct voltage.
3. Check the Xstation power cord continuity.

Did you find a problem?

NO Go to Step 2.

YES Correct the problem and retry the failing procedure.

Step 2. External Devices

(From Step 1)

1. Turn the Xstation and display power off.
2. Disconnect and label all cables from the serial ports (S1 and S2), the parallel port, and Ethernet or Token-Ring ports.
3. Disconnect network:
 - If using an Ethernet system board, connect the Ethernet wrap plug in place of the removed Ethernet cable.
 - If using a Token-Ring system board, disconnect the Multiple Access Unit (MAU) plug from the Token-Ring network. Leave the Token-Ring device cable attached to the Token-Ring connector. The MAU plug provides the wrap connection for the Token-Ring when it is disconnected from the network (expect a 6602 072D LAN error code). The wrap connector is required for successful testing.
4. Disconnect the mouse (expect a 170 error code).
5. Disconnect the keyboard (expect a 301 error code).
6. Turn on the Xstation and display. The Xstation will automatically be reconfigured during POST.
7. Retry the failing procedure.

Note: Either a keyboard or a mouse is needed to use the Xstation graphical menus.

Does the same problem occur?

NO One of the removed devices is associated with the problem. To identify the failing port or external device, run external wrap tests on all external ports, if possible: serial (S1 and S2), parallel, and Token-Ring or Ethernet. If another error is found, go back to "Start of Call." If no error is found, reconnect each of the devices until the failure returns. If possible, move that device to another port. If the failure follows the device, exchange that device and associated cabling or have it serviced, and retry the failing procedure. If the failure is associated with the serial fan out cable, test the continuity of the cable. See the diagram on page 7-0010-13.

If the failure persists, go to Step 3. If the problem is corrected, go to Step 6

YES Go to Step 3.

Step 3. Voltage Analysis Under Load

(From Step 2)

1. If necessary, turn off the Xstation power and remove from chassis. Turn on the Xstation
2. Verify that a 65 watt Xstation power supply is installed.
3. Check pin 1 (+POWERGOOD) for a positive logic level between +2.4 volts and +5 volts. Check the power supply connector (pins 2 through 14) for the DC voltages (+ or - 10%) shown in the following table.

Pin Number	Signal
1	+ POWERGOOD
2	GND
3	+12V
4	-12V
5	GND
6	GND
7	+5V
8	+5V
9	+5V
10	+5V
11	GND
12	GND
13	9V RET (See note)
14	-9V (See note)

Note: All voltages must be measured with respect to Power Supply Ground (pin 2, 5, 6, 11 or 12), except for - 9V (pin 14) which must be measured with respect to 9V return (pin 13).

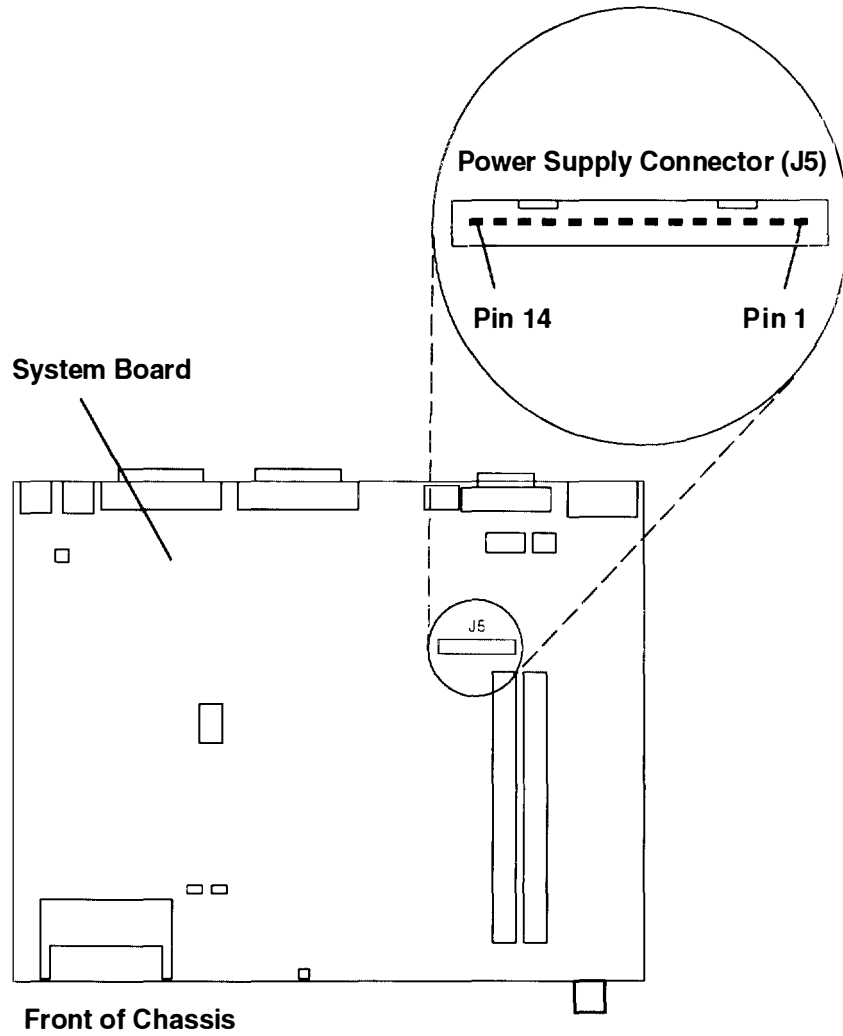

Front of Chassis
Are the voltages present and within tolerance?
NO Record the incorrect voltage (____v), and go to Step 4.
YES Go to Step 4.

Step 4. Internal Devices

(From Step 3)

Error codes, as shown in Step 6, may occur during this procedure. Record the physical configuration and setup of the Xstation. The **Power On Self Test (POST)** option in the Statistics and Logs menu can be selected to identify the last configuration changes.

1. Turn off the Xstation power and remove the chassis.
2. Remove the Optional FLASH card, if installed.
3. Remove all DRAM SIMMs in sockets J43 and J42 as referenced on page 6-2.
4. Turn on the Xstation power and retry the failing procedure.

Does the same problem occur?

NO One of the removed internal FRUs appears to be associated with the problem. Reinstall or exchange each FRU removed and retry the failing procedure until the FRU is isolated or all possibilities are exhausted; if the FRU is isolated, replace that FRU.

If this action fails to solve the problem, go to Step 5. If the problem is corrected, go to Step 6.

YES Go to Step 5.

Step 5. Voltage Analysis with No Load

(From Step 4)

1. Turn the Xstation off.
2. Verify that a 65 watt Xstation power supply is installed.
3. Unplug the power supply connector from the system board.
4. Turn on the Xstation power.
5. Check pin 1 (+POWERGOOD) for a positive logic level between +2.4 volts and + 5 volts. Check the power supply connector (pins 2 through 14) for the DC voltages (+ or - 10%) shown in the following table.

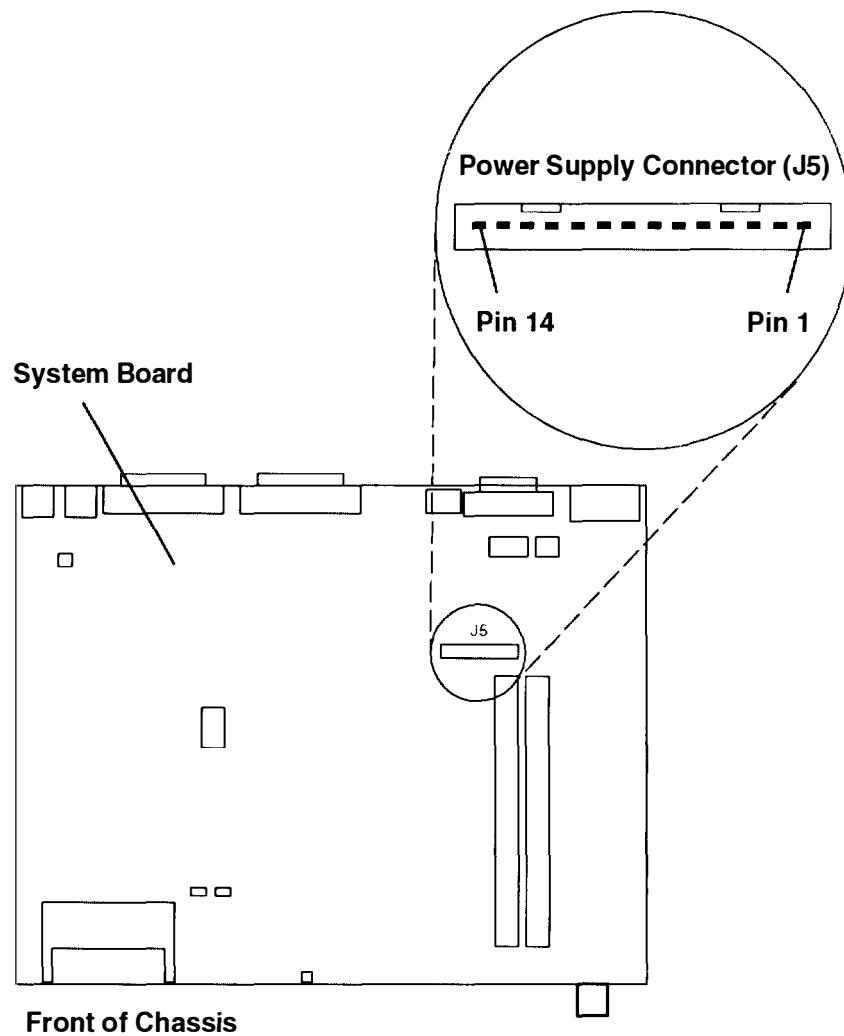

Pin Number	Signal
1	+ POWERGOOD
2	GND
3	+12V
4	-12V
5	GND
6	GND
7	+5V
8	+5V
9	+5V
10	+5V
11	GND
12	GND
13	9V RET (See note)
14	-9V (See note)

Note: All voltages must be measured with respect to Power Supply Ground (Pin 2, 5, 6, 11, or 12), except for -9V (pin 14) which must be measured with respect to 9V return (pin 13).

Are the voltages present and within tolerance?

NO Replace the power supply, verify the voltages, and go to Step 6.

YES Exchange in order and retry the failing procedure:

- a. For displays with detachable cables, check the continuity of the signal cable as shown in "Step 4. Display Raster Test" on page 7-0030-2 of "MAP 0030: Displays." If the cable is good, have the display serviced. For other displays, replace the display.
- b. The system board.
- c. The keyboard.

When the problem is isolated, replace the isolated FRU, and go to Step 6. The problem should be resolved since all FRUs should have been exchanged. However, if the problem persists, go to "Start of Call" on page 7-0000-1 and reassess the problem.

Step 6. Reassemble Xstation and Return to Customer

(From Steps 2, 4, and 5)

When the problem is corrected, reconnect all of the remaining FRUs removed and all cables (including the fan). Each reinstalled option may display a configuration-change error code as listed in the following table. It is normal to have configuration error codes. Repower and recheck the codes. To verify the Xstation configuration and setup, go to "MAP 0040: Diagnostics," select **Statistics and Logs** from the **Main Menu**, then select **Power On Self Test (POST)**. Run all tests to assure that all problems have been corrected.

Error Code	Description of Configuration Change
161, 169	Display
162	NVRAM checksum. Turn off the Xstation, then turn on to recalculate the checksum.
163, 167	Xstation file system (NVRAM, FLASH). Refer to "MAP 0010 Start MAPs," Step 10 on page 7-0010-14.
164	DRAM (SIMMs)
168	Optional FLASH Card
170	Mouse
171	Keyboard
172	Serial Port Device
6602 072D	Token-Ring device cable is plugged into the Token-Ring connector, but disconnected from the Token-Ring LAN network.
6602 0711	Token-Ring device cable is unplugged from the connector
8802	Ethernet cable is disconnected and the wrap plugs are not installed.

MAP 0030: Displays

Purpose of this MAP

This MAP guides the trained service personnel in isolating and resolving display problems.

Step 1. Power Indicator

1. Turn the display power off.
2. Ensure that the display power cord is plugged in to a power outlet.
3. Turn on the display and adjust the display controls (contrast, brightness). Refer to Step 7 of "Connect the Cables" on page 1-7.
4. Observe the display power indicator.

Is the display power indicator lit?

- | | |
|------------|---------------|
| NO | Go to Step 2. |
| YES | Go to Step 4. |

Step 2. Power Check

(From Step 1)

1. Turn off the display power.
2. Unplug the display power cord from the power outlet.
3. Check the power outlet with a meter for correct voltage.

Was the voltage correct?

- | | |
|------------|--|
| NO | Have the customer correct the power problem. |
| YES | Go to Step 3. |

Step 3. Power Cable Check

(From Step 2)

Check the display power cable with a meter for continuity.

Was cable continuity good?

- | | |
|------------|----------------------------|
| NO | Replace the cable. |
| YES | Have the display serviced. |

Step 4. Display Raster Test

(From Step 1)

The Xstation has a display problem; use the following procedure to isolate the failure. If your display is not an 8508, 8517, 5081, 6091, or 6091i, consult the documentation for your display.

1. Turn off the display and Xstation power.
2. Unplug the display signal cable from the Xstation.
3. Turn the contrast control to its maximum position.
4. Turn the brightness control to its middle position.
5. Turn on the display and Xstation.

Note: Powering up the Xstation without the display attached resets the Xstation display parameters. This may resolve some unreadable screen conditions

6. If the display has a self-test button behind the service control cover below the screen, press and hold the button.

The screen should be white or light gray; a black bar should be on the top, the bottom, or both for displays 8508, 8517, 5081, 6091, or 6091i.

Is the display not listed above, or if listed, is the screen image correct?

- NO** For display 8508, check the cable for continuity (see the table on page 7-0030-3). If the cable checks good, replace the display. If the cable is defective, replace the cable and retry the failing procedure.
- For displays with a detachable cable, check the cable for continuity (see the table on page 7-0030-3). If the cable checks good, have the display serviced. If the cable is defective, replace the cable and retry the failing procedure.
- YES** For display 8508, 8517, 5081, 1091, 6091, and 6091i, check the display signal cable for continuity (see the table); if the cable checks good and no signal is shorted to ground, reconnect the display and go to step 5; if the cable is defective, replace the cable and retry the failing procedure.
- For all other displays, go to Step 5.

For displays 1091-051 and POWERdisplay 16S, use display cable 09G3588:

Display Cable 09G3588	
Pin	Signal
1	Video Red
2	Video Green
3	Video Blue
13	Horizontal Sync (white)
14	Vertical Sync (black)
4, 9, 11, 12	Reserved
5-8, 10	Ground
14, 15	Connected

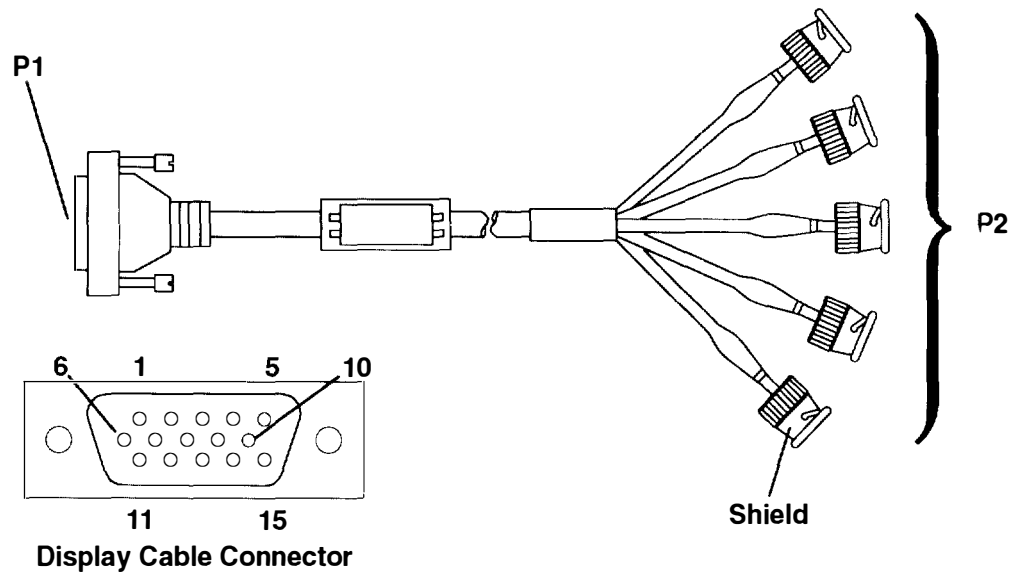

For displays 5081-01x, 6091-0xx, and POWERdisplays 16 and 19, use display cable 58F2901:

Display Cable 58F2901	
Pin	Signal
1	Video Red
2	Video Green
3	Video Blue
13	Horizontal Sync (white)
14	Vertical Sync (black)
4, 9	Reserved
5-8, 10-12, 15	Ground

Step 5. Display Configuration

(From Step 4)

To ensure the display is properly configured, do the following:

1. Ensure the display jumpers (JP10) are set to the positions indicated in the table below, unless otherwise instructed. Also refer to the table below to verify the display screen resolution, frame rate, cable, and mode switch setting. If a problem is found, correct the problem and retry the failing procedure.

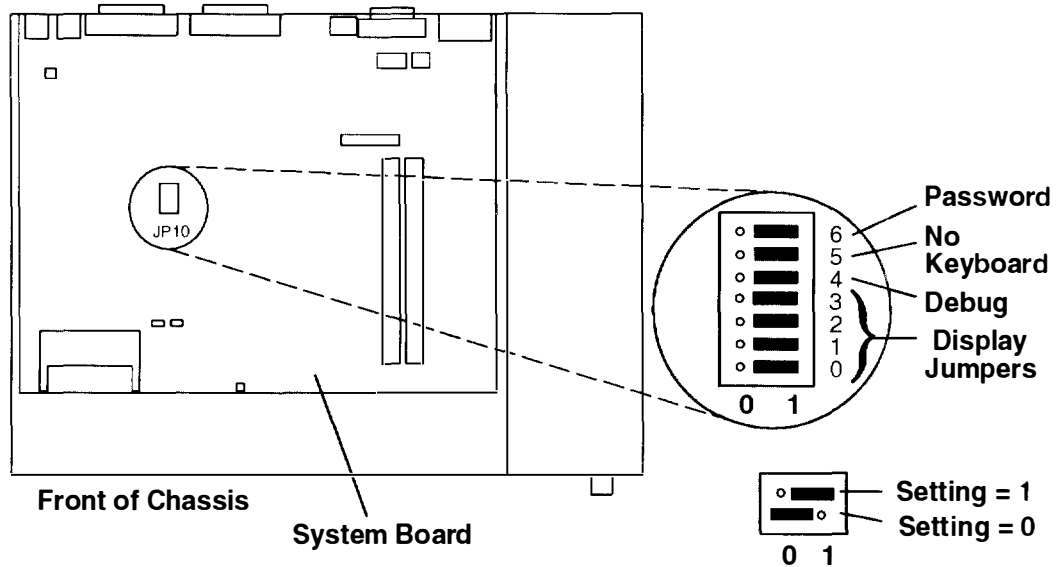

Display Type	Hex Code	Display Jumper 3 2 1 0	Screen Resolution	Frame Rate (Hz)	Mode Switch/ Button	Display Cable
8508 19" Mono	F777	1 1 1 1	1280 x 1024 x 8	67	–	–
8517 17"	F22A	1 1 1 1	1024 x 768 x 8	69.96	–	–
5081-016	F444	1 1 1 1	1280 x 1024 x 8	60	–	58F2901
5081-019	F444	1 1 1 1	1280 x 1024 x 8	60	–	58F2901
6091-016	F444	1 1 1 1	1280 x 1024 x 8	60	out	58F2901
	D444	1 1 0 1		77	in	
6091-019	F444	1 1 1 1	1280 x 1024 x 8	60	2	58F2901
	E444	1 1 1 0		67	3	
6091-019i	F444	1 1 1 1	1280 x 1024 x 8	60	–	58F2901
	D444	1 1 0 1		77	–	
6091-023	F444	1 1 1 1	1280 x 1024 x 8	60	–	58F2901
1091-051	F7F7	1 1 1 1	1280 x 1024 x 8	72	–	09G3588

Display Type	Hex Code	Display Jumper 3 2 1 0	Screen Resolution	Frame Rate (Hz)	Mode Switch/ Button	Display Cable
ValuePoint 6314, 6319	FAAA	1 1 1 1	1024 x 768	60	-	-
	2AAA	0 0 1 0		70	-	-
ValuePoint 6317, 6324, 6325, 9524, 9525	FAAA	1 1 1 1	1024 x 768	60	-	-
	2AAA	0 0 1 0		70	-	-
	BAAA	1 0 1 1	75.8	-	-	
	AAAA	1 0 1 0	1280 x 1024	60	-	-
ValuePoint 9527, 9521	FAAA	1 1 1 1	1024 x 768	60	-	-
	2AAA	0 0 1 0		70	-	-
	AAAA	1 0 1 0	1280 x 1024	60	-	-
	DAAA	1 1 0 1		77	-	-
POWERdisplay 16	F444	1 1 1 1	1280 x 1024 x 8	60	out	58F2901
	D444	1 1 0 1		77	in	
POWERdisplay 16S	F7F7	1 1 1 1	1280 x 1024 x 8	72		09G3588
POWERdisplay 19	F444	1 1 1 1	1280 x 1024 x 8	60	-	58F2901
	D444	1 1 0 1		77	-	

Notes:

1. Powering up the Xstation without the display attached resets the Xstation display parameters. This may resolve some unreadable screen conditions.
 2. After making changes to the display jumper settings, verify that the display's Mode Switch or Button is in the position indicated in the table above. The Mode Switch or Button is located below the display screen as shown on page 1-8.
 3. The Hex Code has four digits. The first digit identifies the display jumper setting. The last three digits are the display ID code.
 4. The Hex Code can be verified on the Base Configuration Screen of the Xstation 140 Configuration Menus.
2. If the display is legible, go to "MAP 0040: Diagnostics" and select **Base Configuration** from the Main Menu. Verify that the display ID code matches the Hex code for that display in the preceding table. If a problem is found, correct the problem by adjusting the display jumpers or replacing the display cable. Retry the failing procedure.
 3. If the display is legible, go to "MAP 0040: Diagnostics" and select **Test the Terminal Run Tests One Time**, and the **Display** options. Run all tests and search for the problem. If a different problem is detected, go to "Start of Call" on page 7-0000-1 and correct that problem first.
 4. If the problem persists for displays 5081, 6091, and 6091i, refer to the respective service manual and have the display serviced. For other displays, replace the display.
 5. If the above action fails to solve the problem, reinstall the old display and go to "MAP 0020: Power" to chronologically isolate the FRU.

MAP 0040: Diagnostics

Purpose of this MAP

The Xstation's Power-On Self-Test (POST) provides the first layer of diagnosis for investigating the nature of a specific problem. Further diagnostics should be consulted for additional isolation of the problem.

POST Checkpoint

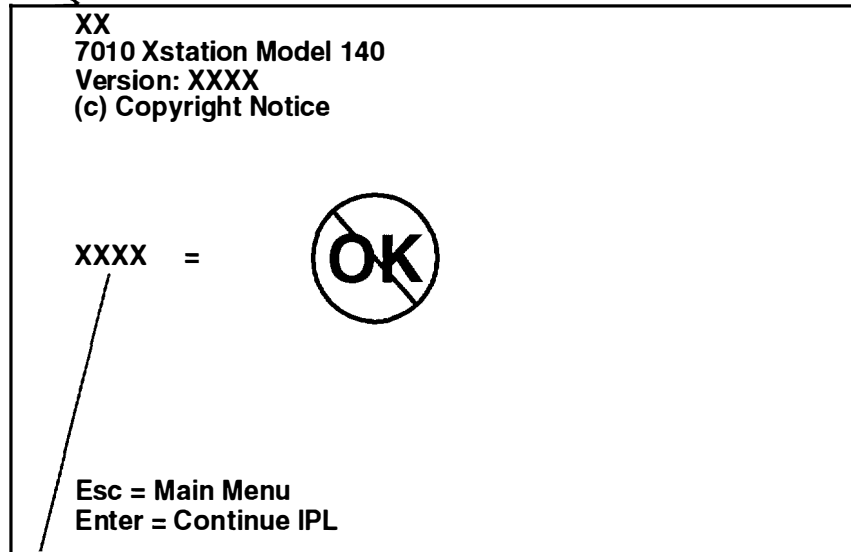

Error Code

POST and LAN Statistics Screen

Pressing the F5 key while the POST and LAN Statistics screen is displayed will display the service message buffer (in English only). The cursor up, cursor down, page up, and page down keys are active while viewing the service message buffer.

To return to the POST and LAN Statistics screen from the service message buffer, press the Esc key.

A POST log is maintained in nonvolatile RAM (NVRAM) and can be viewed through the Xstation's Main Menu. To display the Main Menu:

- Press the Esc key while the POST and LAN Statistics screen is displayed.
- Or, press the Alt and Print Screen (SysRq) keys together while in an X-Windows session.

When the Main Menu appears, click on the **Statistics and Logs** button, then click on the **Power On Self Test (POST)** button to display the POST log.

The Xstation's menu system was designed to be similar to SMIT. In addition, the Test the Terminal menu is similar to that in the Xstation 150.

The Test the Terminal selections are an extension of the Power-On Self-Test (POST). These tests should be consulted if the Power-On Self-Test (POST) produces the "not OK" icon.

For additional service information, press the F1 key whenever an error message is displayed.

Step 1. Enter Diagnostics

1. If you are logged on to the host system, record all of the information that identifies the problem. Log off the system, (hold down the Ctrl and Alt keys, and then press the Backspace key), wait for the Reboot message, then turn the Xstation power off.
2. Turn on the Xstation power.
 - a. Verify that the power supply LED is lit.
 - b. Verify that all LEDs on the keyboard flash on, then off during power-up.
 - c. Verify that the POST checkpoints, the startup message, and LAN statistics display on the screen.
 - d. Record any displayed error code, then press the Esc key to display the Xstation's Main Menu.

Did a graphical menu (such as the Main Menu or Test the Terminal) appear?

- NO** Go to "MAP 0020: Power" on page 7-0020-1 to chronologically isolate the problem.
- YES** Go to Step 2.

Step 2. Select

(From Step 1)

The Xstation's Main Menu provides a comprehensive set of selections to assist the trained service person in isolating problems.

The screenshot shows the Xstation Main Menu interface. At the top left is a circular logo with the word "logo" inside. To its right is a rectangular box containing the text "Copyright Statement" and "Version" below it. Below these are three sections of menu items, each with a title and a list of options:

- Xstation Session:**
 - X-Windows
 - Telnet Terminal
 - Asynchronous Terminal
- Configuration:**
 - Select Menu Language . . . English (U.S.)
 - Xstation Configuration
 - Base Configuration
- Utilities:**
 - Startup Messages
 - Statistics and Logs
 - Test the Terminal

At the bottom of the menu are four buttons: "Save Changes", "Restore Defaults", "Reboot", and "Help".

Base Configuration

This selection allows you to view and change some of the Xstation's base hardware configuration, such as display ID, amount of installed memory and the Xstation hardware address.

Utilities

This section of the Main Menu controls diagnostic information and tests.

Startup Messages

The startup messages displayed by this selection allow you to view (in English only) the initial program load (IPL) progress in order to verify configuration of the Xstation and communication with the host.

Statistics and Logs

This section displays (in English only) the LAN, error, and POST logs.

Test the Terminal

This section provides interactive tests for analyzing the Xstation hardware and attached devices.

Step 3. Test the Terminal

(From Step 2)

The **Test the Terminal** option from the Main Menu offers the following choices:

Test the Terminal Menu

Test Selection:

Run Tests One Time Run Tests Continuously

Run All Tests

- Memory
- Keyboard
- Mouse
- Display
- Parallel Port
- Serial Ports/Devices
- LAN Communication

Power-On Self-Test (POST)

Esc

1. If you want the tests that you choose to run continuously, click on the button labeled **Run Tests Continuously**. Otherwise, the tests will run once when you choose them.
2. Select the desired tests.
3. Insert the wrap plugs as prompted.
4. If the test stops with an error message, go to "Step 4. Error Code Analysis" on page 7-0010-5. (Pressing the F1 key provides additional service information)
5. Intermittent problems, including memory, should be tested first by selecting **Run Tests Continuously**.
6. To quit looping after selecting **Run Tests Continuously**, press the Esc key when the loop count message is displayed or turn the Xstation power off.
7. If an attached device failure is suspected:
 - a. If possible, move the device to another port and retry the failing procedure. Assure that the port being used passes its own diagnostics.
 - b. If the failure follows the attached device, refer to the respective service manual
8. If the problem persists, and if a software problem is not suspected, go to "Map 0020: Power" to chronologically isolate the FRU.
9. If a software problem is suspected, contact the system administrator. If all previous actions do not resolve the problem, contact technical assistance.

Step 4. Display

(From Step 3)

Selecting the **Display** option from the Test the Terminal menu produces the Display menu.

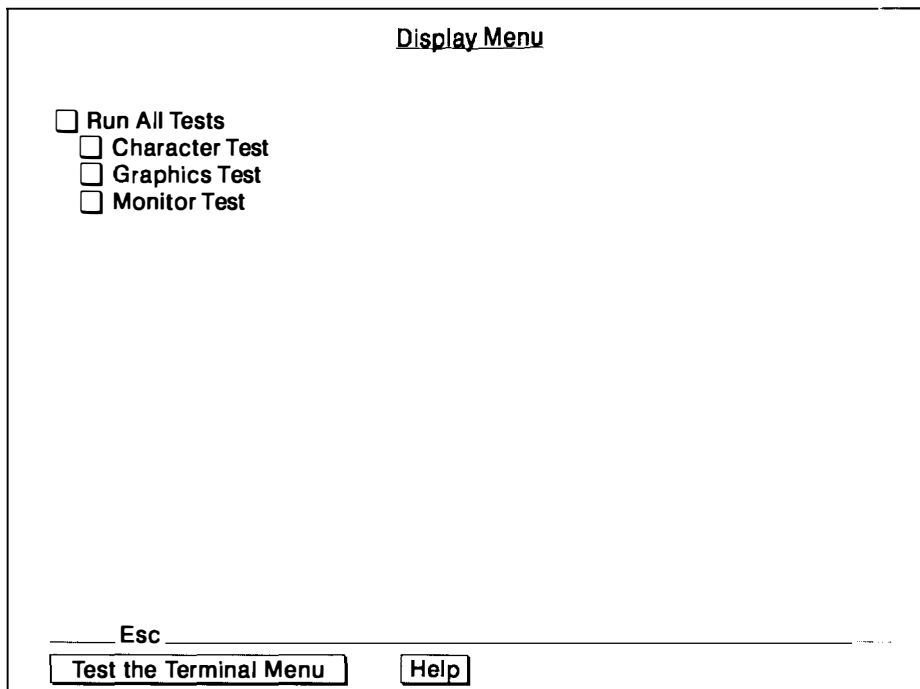

Display Menu

Run All Tests
 Character Test
 Graphics Test
 Monitor Test

Esc

Test the Terminal Menu Help

If the test stops with an error, go to "Step 4. Error Code Analysis" on page 7-0010-5.

Test Screens

Character Test, selected from the preceding Display Menu, produces the character set used by the built in font.

Graphics Test, selected from the preceding Display menu produces a sequence of test screens that can vary according to your display type. Each of these screens displays aspects of the Xstation's graphics capabilities and asks for user verification as to their accuracy. Two examples appear on page 7-0040-6.

Monitor Test produces a sequence of test screens which are used by service personnel to evaluate the display according to the service instructions provided with the display.

Graphics Test

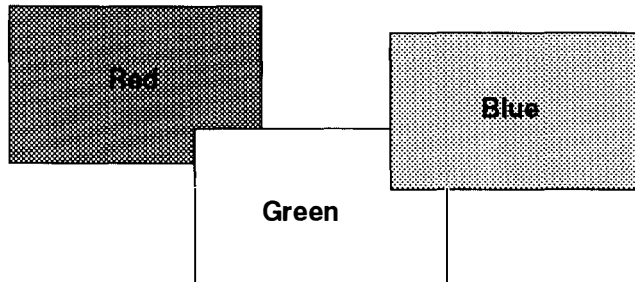

Are the colors correctly displayed?

F5 = Yes

F6 = No

16 COLOR GRAPHICS

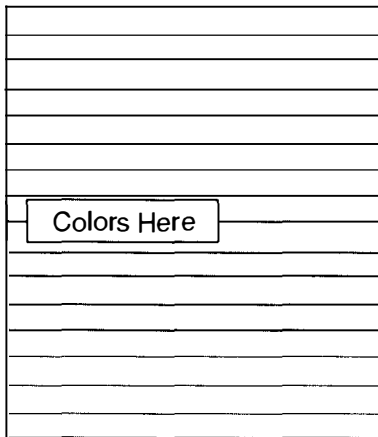

- Black
- Blue
- Green
- Cyan
- Red
- Magenta
- Brown
- White
- Dark gray
- Light blue
- Light green
- Light cyan
- Light red
- Light magenta
- Yellow
- Intensified white

Are the colors correctly displayed?

F5 = Yes

F6 = No

Chapter 8. Removal and Replacement Procedures

Introduction

The 7010 Xstation Model 140 is designed for ease of maintenance. Some of its features are:

- The entire chassis, including the power supply, slides out from within the cover; no fastener removal is required for this important procedure unless security protection devices have been installed by the customer.
- Most of the removal and replacement procedures do not require moving the display from the top of the Xstation cover.
- The power supply is entirely self-contained.
- The fan assembly does not require fasteners.

Electrical Safety

Observe the following safety instruction any time you are connecting or disconnecting devices attached to the system unit.

Note: For a translation of these notices see the *System Unit Safety Information*, Form Number SA23-2652.

DANGER

An electrical outlet that is not correctly wired could place hazardous voltage on metal parts of the system or the devices that attach to the system. It is the responsibility of the customer to ensure that the outlet is correctly wired and grounded to prevent an electrical shock.

Before installing or removing signal cables, ensure that the power cables for the system unit and all attached devices are unplugged.

When adding or removing any additional devices to or from the system, ensure that the power cables for those devices are unplugged before the signal cables are connected. If possible, disconnect all power cables from the existing system before you add a device.

Use one hand, when possible, to connect or disconnect signal cables to prevent a possible shock from touching two surfaces with different electrical potentials.

During an electrical storm, do not connect cables for display stations, printers, telephones, or station protectors for communications lines.

CAUTION:

This product is equipped with a 3-wire power cable and plug for the user's safety. Use this power cable in conjunction with a properly grounded electrical outlet to avoid electrical shock.

Handling Static-Sensitive Devices

Warning: Adapters, planars, SIMMs, and FLASH cards are sensitive to static electricity discharge. These devices are wrapped in antistatic bags, as shown in this illustration, to prevent this damage.

Take the following precautions:

- If you have an antistatic wrist strap available, use it while handling the device.
- Do not remove the device from the antistatic bag until you are ready to install the device in the system unit.
- With the device still in its antistatic bag, touch the bag to a metal frame of the system.
- Grasp cards and boards by the edges. Hold drives by the frame. Avoid touching the solder joints or pins.
- If you need to lay the device down while it is out of the antistatic bag, lay it on the antistatic bag. Before picking it up again, touch the antistatic bag and the metal frame of the system unit at the same time.
- Handle the devices carefully in order to prevent permanent damage.

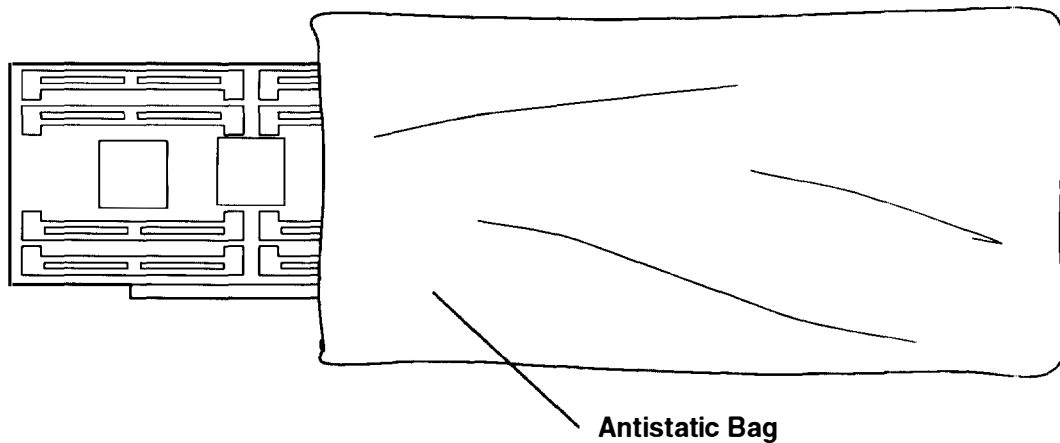

Chassis Assembly

Refer to the specific component removal procedure in this chapter unless you need to disassemble down to the bare chassis.

To remove the chassis assembly, see this illustration, and:

1. Have the customer unlock and remove the security protection devices, if any are installed.
2. Set the Xstation and display power switches to Off.
3. Unplug the Xstation and display power cords from the electrical outlet.
4. Press down on each end of the plastic tab that extends from the upper edge of the rear cover. When the latches disengage, slide out the chassis and power supply as a single unit by pulling on the plastic tab.

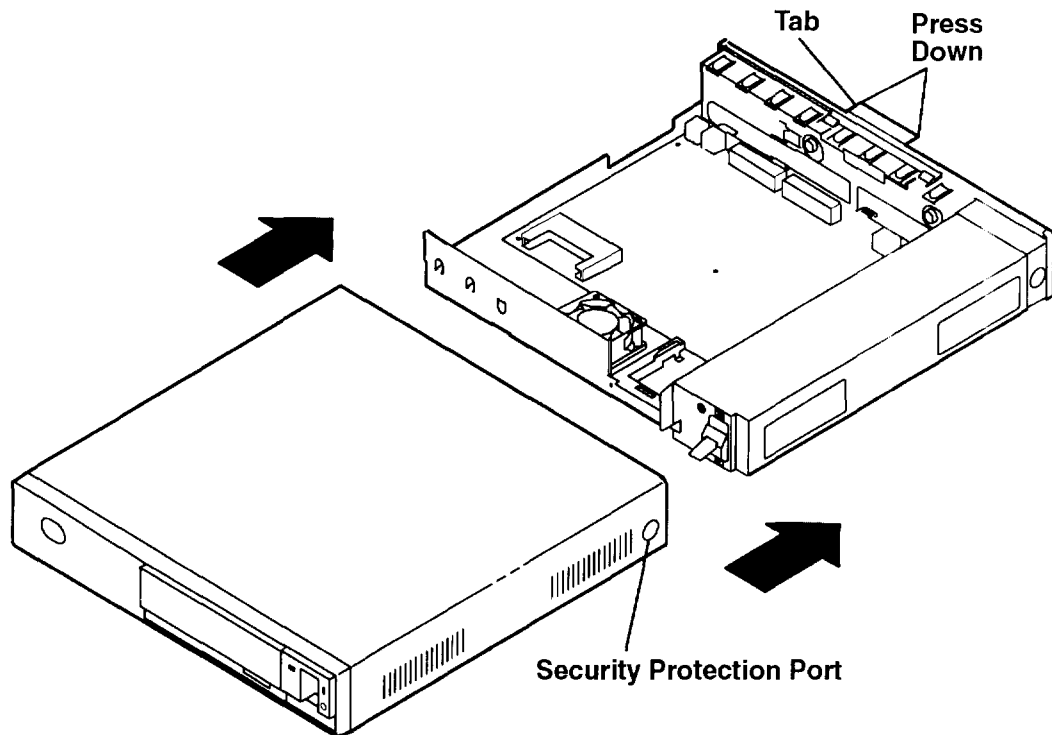

5. Unplug the power cable and all signal cables from the I/O panel.
6. Unplug and remove the power supply.
7. Remove the six hex standoffs from the I/O panel.
8. Remove the five system board mounting screws and the shoulder stud.

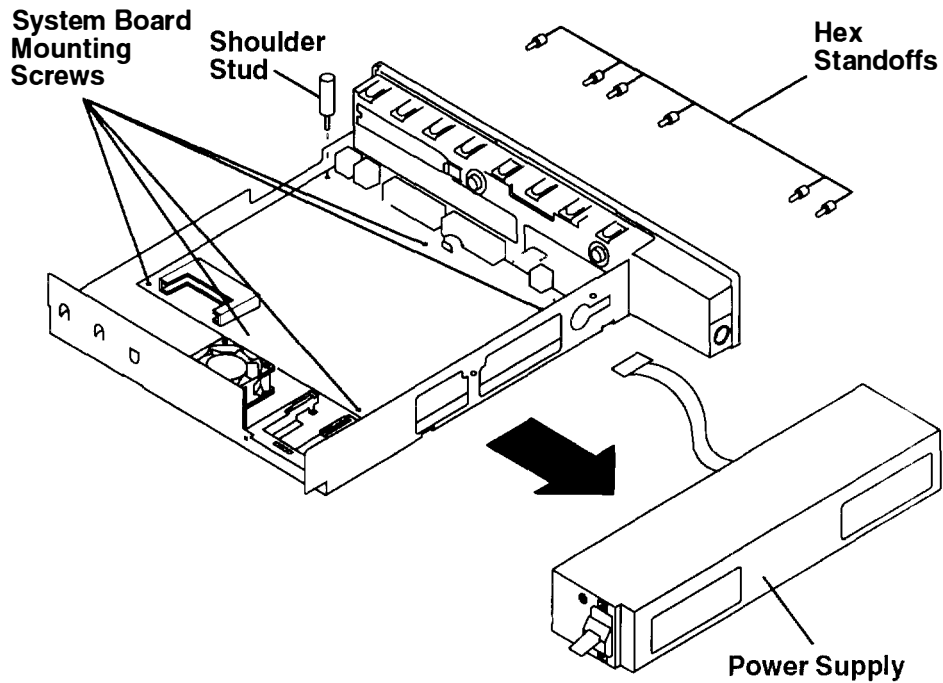

9. Unplug the fan power cable from the system board.
10. Lift out the system board and system board insulator.
11. Remove the fan; the chassis assembly remains.

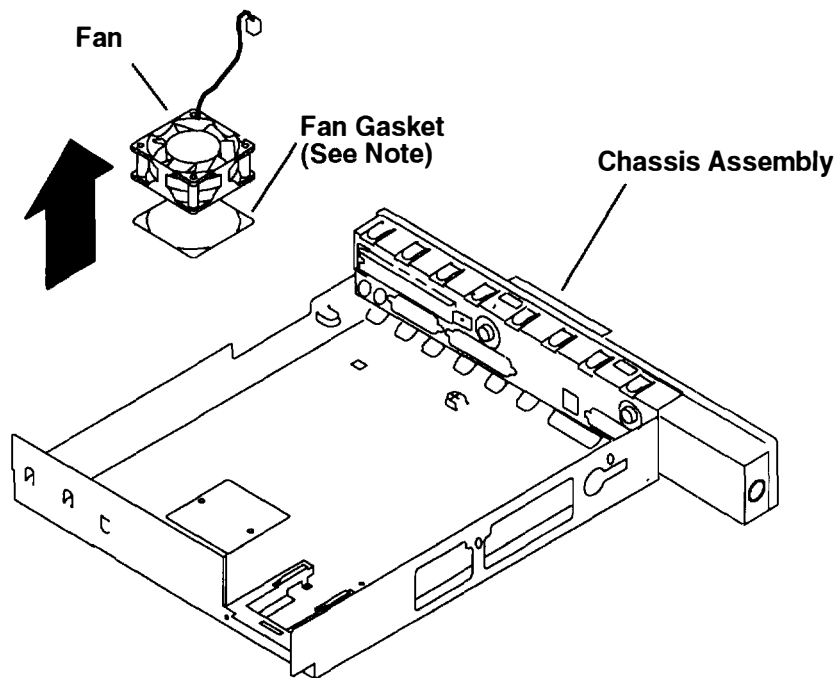
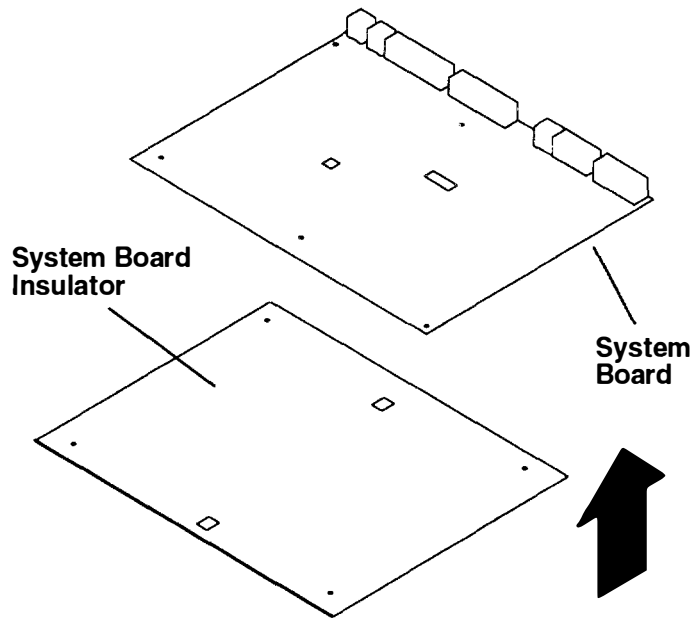

To replace the chassis assembly, ensure that the power switch is in the down position and perform removal steps in reverse order.

Note: A new double-stick fan mounting gasket will be required to reinstall the fan; ensure that the gasket mounting area of the chassis and fan is clean and dry, and ensure that the fan rotates freely.

Power Supply

DANGER

Do not attempt to open the covers of the power supply. Power supplies are not serviceable and are to be replaced as a unit.

To remove the power supply:

1. Perform the first five steps of the removal procedure in “Chassis Assembly” on page 8-3 if not already complete.
2. Unplug the power supply cable from the planar.
3. Remove the three power supply mounting screws, and slide the power supply and attached cable away from the chassis assembly.

To replace the power supply, perform the removal steps in reverse order.

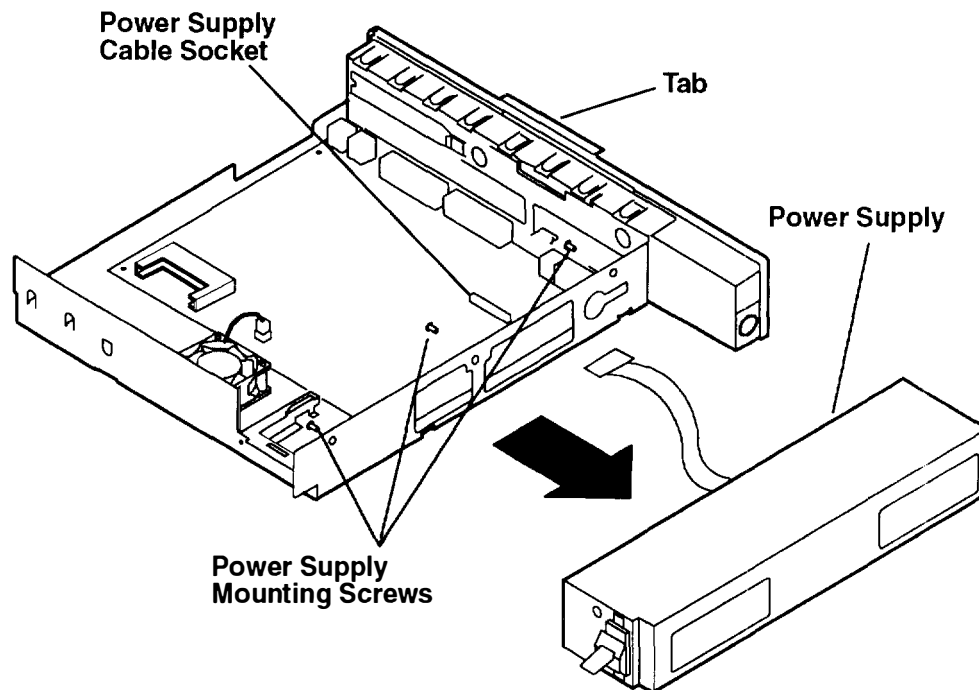

System Board

Notes:

1. Installing a new system board results in new network hardware addresses. The network administrator should be informed of the new addresses which will be furnished on the POST and LAN Statistics Screen shown on page 3-1.
2. In addition, each system board has a unique identification number that is used for access by some programs. If the system board is changed, notify the customer that program authorization may need to be updated.
3. To maintain security, the system administrator must enter a new password.

To remove the system board:

1. Perform the first nine steps of the removal procedure in "Chassis Assembly" on page 8-3 if not already complete.
2. Unplug the power supply cable from the system board.
3. Unplug the fan power cable from the system board.
4. Remove the optional FLASH card, if installed.
5. Unplug and remove the DRAM SIMMs from sockets J43 and J42.
6. Remove the six hex standoffs from the rear plate.
7. Remove the five system board mounting screws and the shoulder stud.
8. Lift the system board assembly up and out of the chassis. The system board insulator can be left in place.

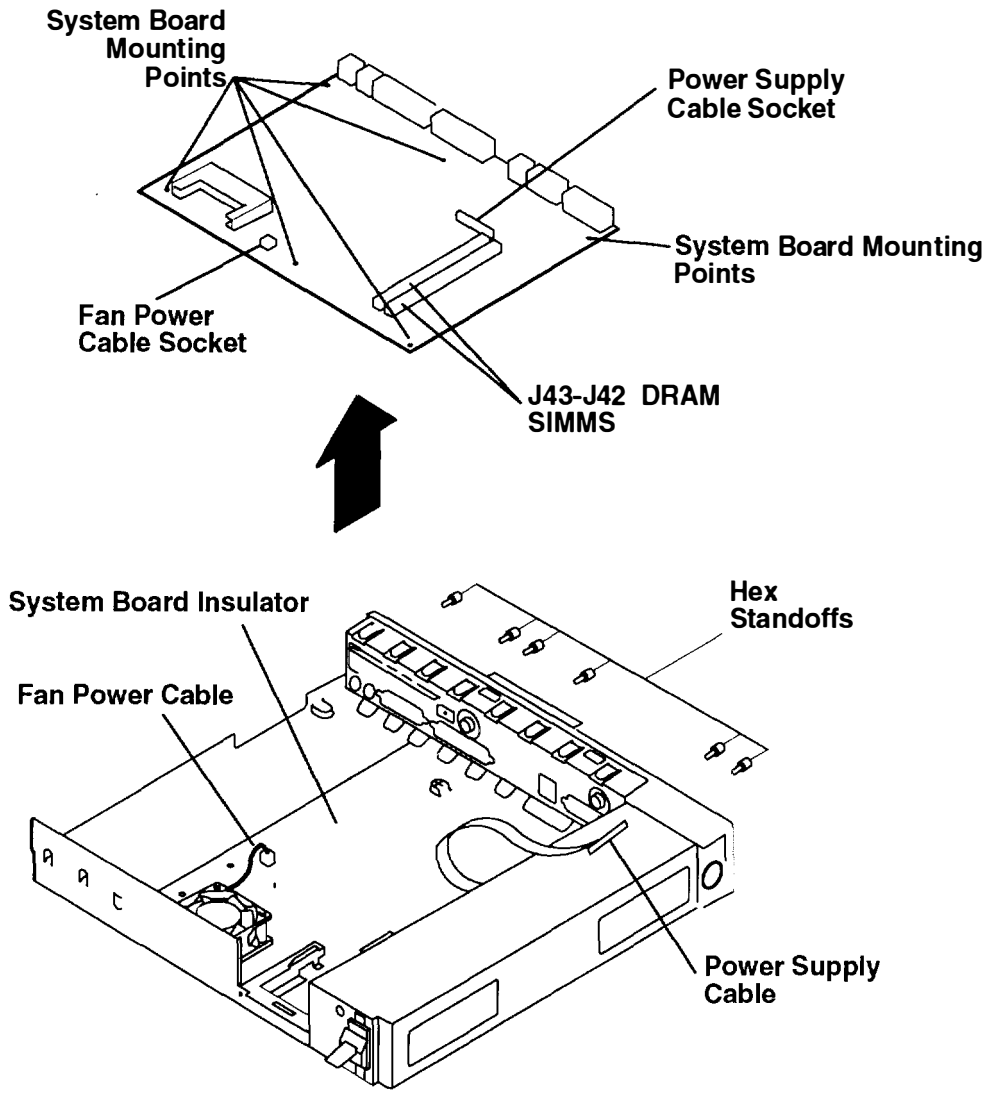

To replace the system board, perform removal steps in reverse order.

Install all removed parts onto the new system board, and configure jumpers JP10 and JP4 to match those on the removed system board.

Fan

To remove the fan:

1. Perform the first four steps of the removal procedure in “Chassis Assembly” on page 8-3 if not already complete.
2. Unplug the fan power cable from the system board.
3. Remove the fan and fan gasket.

Note: The fan gasket has double-stick surfaces to secure the fan to the chassis.

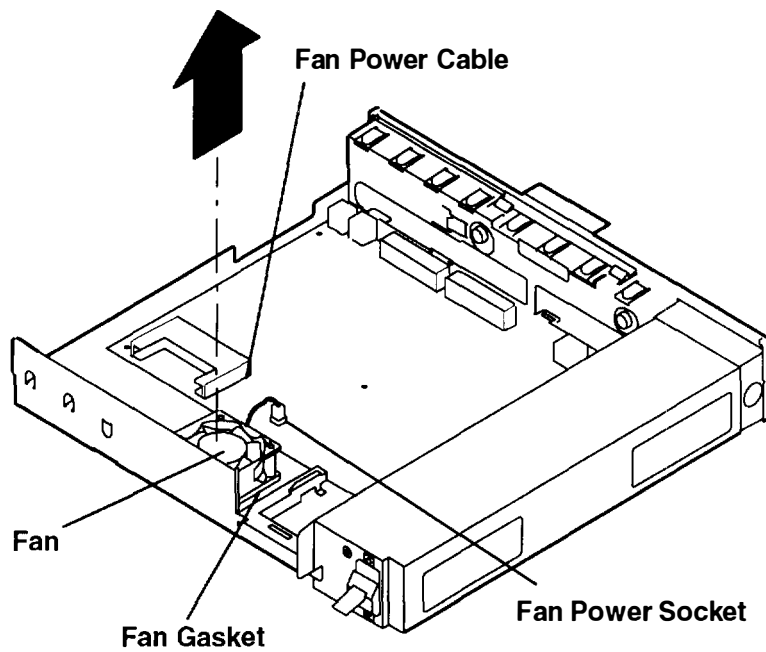

To replace the fan, perform removal steps in reverse order.

Note: A new fan mounting gasket will be necessary for fan reinstallation. Ensure that fan and chassis gasket areas are clean before applying the new gasket. Ensure that the new fan rotates freely.

Cover Assembly

To remove the cover assembly, see this illustration, and:

1. If the display is located on top of the Xstation, move the display.
2. Perform the first four steps of the removal procedure in "Chassis Assembly" on page 8-3 if not already complete; the cover assembly remains.

To replace the cover assembly, perform removal steps in reverse order.

Note: When replacing the chassis/power supply assembly into the cover assembly, ensure that the power switch is in the fully down position.

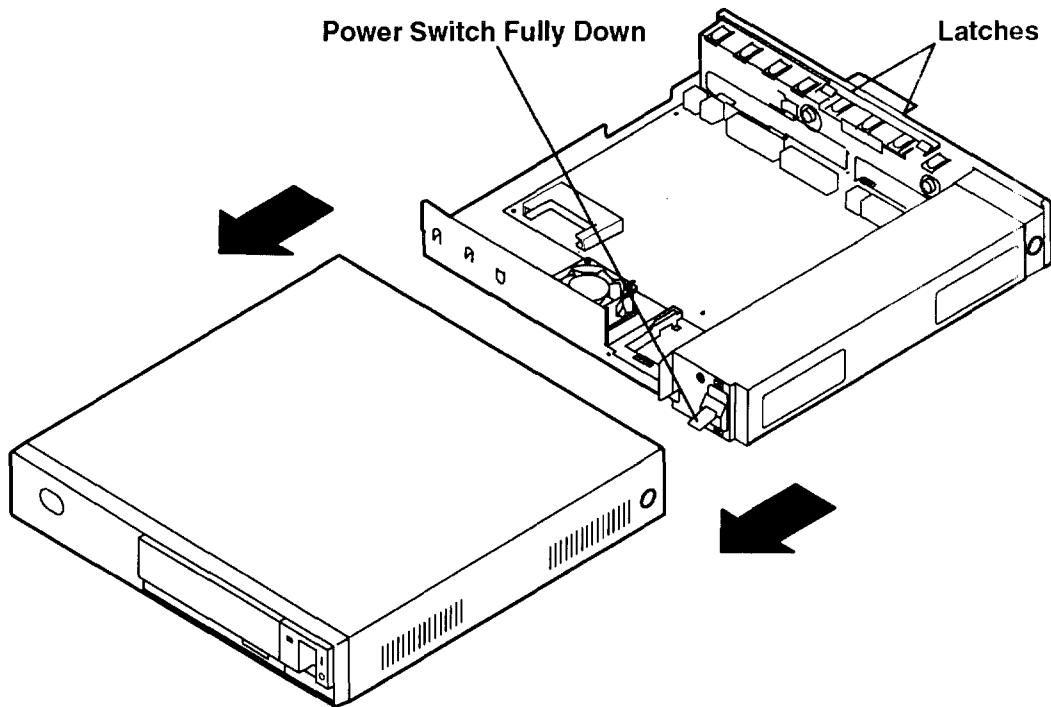

Chapter 9. Parts Information

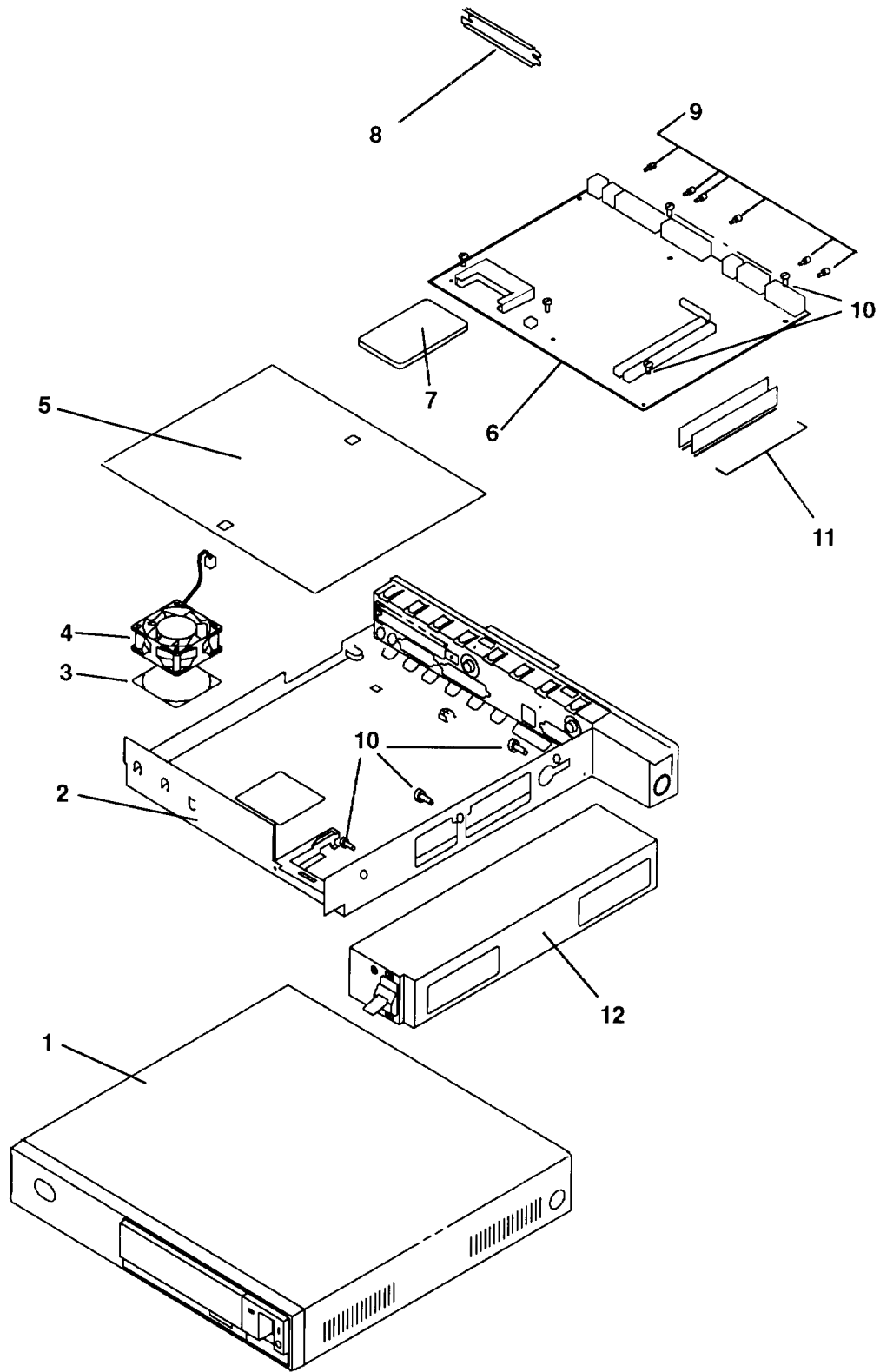

Index Number	FRU Number	Units Per Asm	Description
1	81F8600	1	Cover Assembly
2	31F4020	1	Chassis Assembly
3	53F4003	1	Gasket, Fan Mounting
4	53F3986	1	Fan Assembly
5	71F0000	1	Insulator, System Board
6	43G2831	1	System Board Assembly
7	43G2855	1	Optional FLASH Card, 2M bits
	43G2856	1	Optional FLASH Card, 4M bits
8	6279235	1	EMI Bracket, Blank
9	62X0388	6	Hex Standoff
10	27F4212	8	Screw, System Board, and Power Supply Mount
11	51G8553	2	PS/2 4M-bit Memory Expansion Kit (SIMM)
	51G8554	2	PS/2 8M-bit Memory Expansion Kit (SIMM)
12	32G1902	1	Power Supply

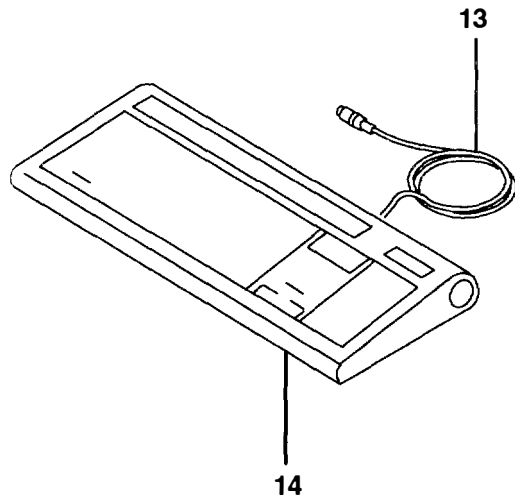

Index Number	FRU Number	Units Per Asm	Description
13	1394609	1	Keyboard Cable
14	1394540	1	Keyboard, United States English
	1394541	1	Keyboard, Canadian French
	1394542	1	Keyboard, German
	1394543	1	Keyboard, Belgian-French/Dutch
	1394544	1	Keyboard, Danish
	1394545	1	Keyboard, Finnish/Swedish
	1394546	1	Keyboard, French
	1395968	1	Keyboard, Icelandic
	1394547	1	Keyboard, Italian
	1394548	1	Keyboard, Norwegian
	1394549	1	Keyboard, Portuguese
	1394550	1	Keyboard, Spanish
	1394551	1	Keyboard, Swiss German/French
	1395984	1	Keyboard, United Kingdom, CSA
	1395985	1	Keyboard, United Kingdom English
	43G2778	1	Keyboard, Netherlands
	1396077	1	Keyboard, Turkish
	30F9388	1	Keyboard, Japan
	10G8753	1	Keyboard, Taiwan-Chinese
	10G8752	1	Keyboard, Korean

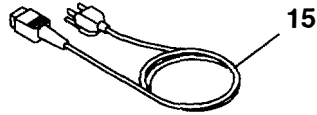

Index Number	FRU Number	Units Per Asm	Description
15	62X0663	1	Power Cable, U.S.
	13F9960	1	Power Cable, Canada, South Korea, Costa Rica, Uruguay
	65X1361	1	Japan
	13F9979	1	Power Cable, Germany, Sweden, Austria, Norway, Belgium, Finland, France, Portugal, Spain
	13F9997	1	Power Cable, Denmark
	14F0015	1	Power Cable, South Africa, Pakistan, Sri Lanka
	14F0033	1	Power Cable, U.K., Hong Kong, Brunei
	14F0051	1	Power Cable, Switzerland
	14F0069	1	Power Cable, Italy, Chile
	14F0087	1	Power Cable, Israel
	13F9940	1	Power Cable, Australia, New Zealand, Argentina
	1838574	1	Power Cable, Thailand
	13F9968	1	Power Cable, Chicago Shielded

To avoid electrical shock, IBM provides a power cable with a grounded attachment plug. Use only properly grounded outlets.

IBM power cables used in the United States and Canada are listed by Underwriter's Laboratories (UL) and certified by the Canadian Standards Association (CSA). These power cords have the following characteristics:

- Electrical cables, Type SVT or SJT
- Attachment plugs complying with National Electrical Manufacturers Association (NEMA) 5-15P, which states:
 - “For 115 V operation, use a UL listed cable set consisting of a minimum 18 American Wire Gauge (AWG), Type SVT or SJT three-conductor cord a maximum of 15 feet in length and a parallel blade, grounding type attachment plug rated at 15 A, 125 V.”
 - “For 230 V operation in the United States use a UL listed cable set consisting of a minimum 18 AWG, Type SVT or SJT three-conductor cable a maximum of 15 feet in length, and a tandem blade, grounding type attachment plug rated at 15 A, 250 V.”
- Appliance couplers complying with International Electrotechnical Commission (IEC) Standard 320, Sheet C13.
- Electrical cables, Type HD21
- Attachment plugs approved by the appropriate testing organization for the specific countries where they are used. NEMA 5-15P states:
 - “For units set at 230 V (outside of U.S.): use a cable set consisting of a minimum 18 AWG cable and grounding type attachment plug rated 15 A, 250 V. The cable set should

have the appropriate safety approvals for the country in which the equipment will be installed and should be marked HAR.”

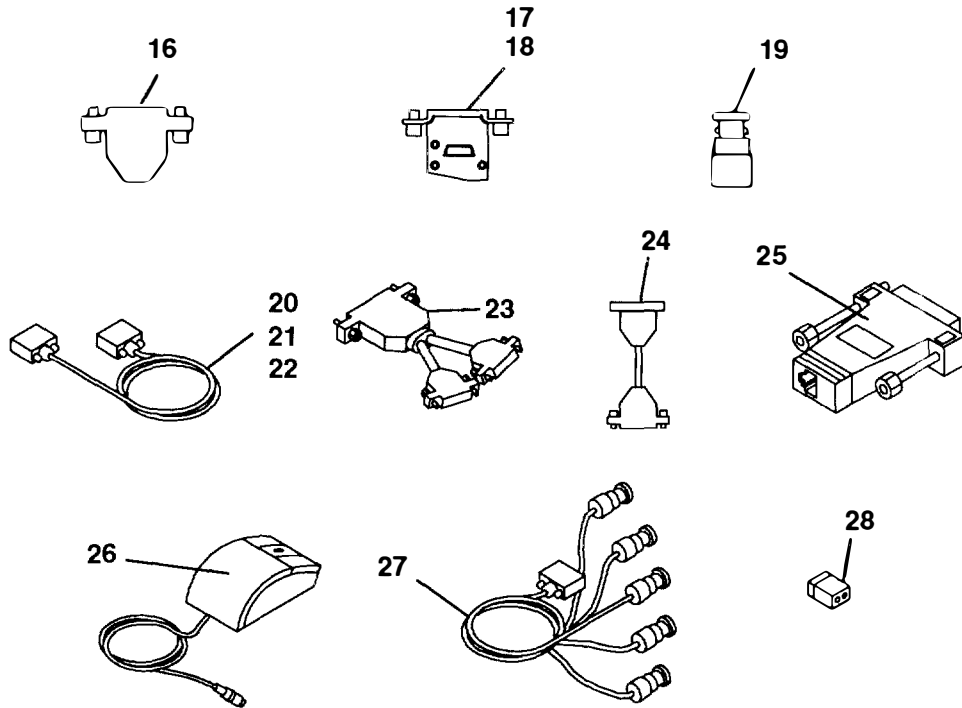

Index Number	FRU Number	Units Per Asm	Description
16	71F1167	1	Wrap Plug, Ethernet Thick (15-pin D Shell)
17	6298964	1	Wrap Plug, Serial
18	71F0690	1	Wrap Plug, Parallel
19	71F1168	1	Wrap Plug, Ethernet Thin (BNC "T-stub" W/25 Ohm Terminators)
20	1525612	1	Printer Cable, Parallel
21	8509386	1	Printer Cable, Serial
22	6339098	1	Token-Ring Device Cable
23	31F4590	1	Serial Port Fan Out Cable
24	70F9814	1	Converter, Ethernet Connector (connects slide-latch connector on LAN cable to the thick Ethernet connector on the I/O panel)
25	43G2821	1	Ethernet Twisted Pair Adapter
26	11F8895	1	Mouse, 3-button
27	09G3588	1	Cable, Display Attachment 1091, POWERdisplay 16S
	58F2901	1	Cable, Display Attachment 5081, 6091, POWERdisplays 16, 19
28		8	Jumper

Appendix A. Moving the Xstation

Warning: Damage resulting from improper handling may void your equipment warranty. Contact your local representative to purchase packing materials or assistance to prepare your system for moving.

Do not place the Xstation on top of any object or surface which will restrict airflow to the chassis. Doing so could prevent proper cooling of the Xstation and cause overheating of system components.

Note: Carrying or moving heavy displays may require two persons.

The following danger and caution notices should be observed if you decide to move your unit. For a translation of these notices see the *System Unit Safety Information*, Form Number SA23-2652.

DANGER

An electrical outlet that is not correctly wired could place hazardous voltage on metal parts of the system or the devices that attach to the system. It is the responsibility of the customer to ensure that the outlet is correctly wired and grounded to prevent an electrical shock.

Before installing or removing signal cables, ensure that the power cables for the system unit and all attached devices are unplugged.

When adding or removing any additional devices to or from the system, ensure that the power cables for those devices are unplugged before the signal cables are connected. If possible, disconnect all power cables from the existing system before you add a device.

Use one hand, when possible, to connect or disconnect signal cables to prevent a possible shock from touching two surfaces with different electrical potentials.

During an electrical storm, do not connect cables for display stations, printers, telephones, or station protectors for communications lines.

CAUTION:

This product is equipped with a three-wire power cable and plug for the user's safety. Use this power cable in conjunction with a properly grounded electrical outlet to avoid electrical shock.

DANGER

To prevent shock hazard, disconnect the power cable from the electrical outlet before relocating the system.

1. If you are logged on to a host system, log off the attached network (hold down the Ctrl and Alt keys and then press the Backspace key). Wait for the reboot message to appear.
2. Turn off the Xstation system unit, display, and all attached separately powered devices.
3. Unplug the Xstation system unit, display, and all attached separately powered devices from power outlets.
4. Be sure to label all of the cables as you disconnect them.
5. Check all of the electrical power outlets in the location to which you are moving for correct wiring, voltage, and grounding before attaching the Xstation, display, or separately powered devices.
6. Connect all signal cables to the display and system unit before plugging any power cables into electrical outlets.
7. Refer to “Step 4. Position the Xstation” on page 1-10 for Xstation positioning considerations.

Appendix B. Securing the Xstation

The Xstation chassis assembly and outer cover can be secured by placing a lock through the convenient security protection port.

1. Close your lock through the security protection port on the right side of the Xstation toward the rear.
2. Tether your security device (fiber optics, cable) through the security protection port or lock.

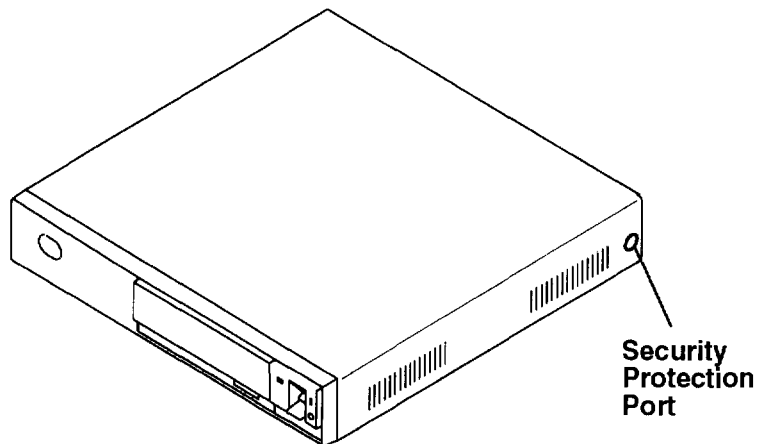

Index

A

- address
 - alternate, 3-5
 - hardware, 3-5
- asynchronous terminal mode, 3-2, 3-16

C

- cables
 - connecting, 1-3
 - display, 1-7, 7-0030-2
 - Ethernet, 1-5, 2-9
 - T-connector, 1-5
 - Token-Ring, 1-6
- chassis assembly
 - removing, 2-3, 8-3
 - replacing, 2-15
- configuration
 - central, 3-2
 - error codes, 5-3
 - local, 3-2
 - using menu system, 3-3
- cover assembly, removing, 8-10

D

- diagnostics. *See* test
- display
 - cables, 1-7, 7-0030-2
 - connecting, 1-7
 - jumpers, 2-11, 7-0030-4
 - mode switch, 1-8, 7-0030-4

E

- error analysis, 5-2
- error codes
 - configuration, 5-3
 - network, 5-4
 - nonconfiguration, 5-3
 - Token-Ring, 5-4
- Ethernet adapter
 - configuring, 2-9
 - using twisted pair connection, 2-10

F

- fan, removing, 8-9
- FLASH card
 - installing optional, 2-7
 - write-protect switch, 2-7
- front view of Xstation, 1-1, 6-1

H

- handling static-sensitive devices, 2-2, 8-2

- hardware
 - address, 3-5
 - alternate, 3-5
 - setup, 1-1
- host
 - logging off from, 5-1, A-2
 - registering Xstation with, 3-5

I

- I/O panel, 1-4, 6-2
- initial program load (IPL), 3-3, 7-0040-3
- installing
 - optional FLASH card, 2-7
 - serial port fan out cable, 2-16
 - SIMMs, 2-5
- inventory, 1-1

J

- jumpers
 - alternate boot, 2-14
 - display, 2-11, 7-0030-4
 - Ethernet, 2-9
 - password-reset, 2-13
 - recover boot, 2-13
 - speaker, 2-14

K

- keyboard
 - connecting, 1-4
 - using, 4-2

L

- language, selecting, 3-2, 3-3
- logging off from host, 5-1

M

- Main Menu
 - displaying, 3-2, 7-0040-3
 - selecting language from, 3-2 3-3
 - selecting terminal mode from 3-2
 - startup messages, 3-3, 7-0040-3
 - Statistics and Logs, 3-4, 7-0040-3
 - Test the Terminal, 3-4, 7-0040-3, 7-0040-4
- maintenance package, 6-3
- MAPs, start of call, 7-0000-1
- mode switch, setting, 1-8, 2-11
- mouse
 - care and cleaning, 4-4
 - connecting, 1-4
 - using, 4-3
- moving the Xstation, A-1

N

network

- cables, connecting, 1-5
- error analysis, 5-4
- establishing communication with, 3-5

network connection, configuring Xstation for, 3-6--3-14

nonconfiguration error codes, 5-3

P

parallel devices, 1-6

parts information, 9-1

password, reset jumper, 2-13

positioning Xstation, 1-10

POST and LAN statistics screen, 3-1, 5-2

POST logs, 3-4, 7-0040-1, 7-0040-3

power cables, connecting, 1-9

power supply, removing, 8-6

power-on self-test (POST), 3-1, 5-2

problem determination, 5-1

R

rear view of Xstation, 6-2

recommended actions, 5-5

removals and replacements, 8-1

S

securing the Xstation, B-1

serial devices, 1-6

serial number, 1-1

serial port

- configuration, 3-17

- fan out cable, 2-16

service inspection, 6-5

setup

- hardware, 1-1

- network connection, 3-5

side view of Xstation, 6-1

SIMMs, installing, 2-5

specifications, 6-3

start of call, 7-0000-1

starting the Xstation, 3-1

Statistics and Logs Menu, 5-3

system board

- illustration, 6-2

- removing, 8-7

system jumpers, 2-11

T

telnet terminal mode, 3-2, 3-15

terminal mode, choosing, 3-15

test, display port, 7-0040-5

Test the Terminal menu, 3-4, 7-0040-3, 7-0040-4

Token-Ring

- cables, 1-6

- error codes, 5-4

tools, service, 6-3

V

vertical stand, 1-10

X

X-Windows mode, 3-2, 3-15

Xstation

- configuration

 - central, 3-2

 - local, 3-2

 - using menu system, 3-3

- I/O panel, 1-4, 6-2

- locations, 6-1

- Main Menu, 3-2, 7-0040-3

- moving, A-1

- positioning, 1-10

- registering with host, 3-5

- securing, B-1

- setup, 1-1

- specifications, 6-3

- starting, 3-1

- system board, 6-2, 8-7

Printed in the U.S.A.

 Place Form Number barcode
lower left corner here.