

June 1998



Cartesia Gateway – Smallworld Edition Technical White Paper

Copyright and Trademark Information

Copyright © 1998-2000 by Tadpole Technology Plc
Cartesia Gateway is a trademark of Tadpole Technology Plc
All other trademarks recognised
Specifications are subject to change without notice

Issue 1.0
Part Number XXXXX

Contents

1.	BACKGROUND	3
2.	PRODUCT OVERVIEW	4
3.	DESIGN CONSIDERATIONS	5
3.1	Choice of operating environment.....	5
3.2	Choice of map data transfer format	5
4.	PRODUCT ARCHITECTURE	7
5.	CONFIGURATION & CUSTOMISATION	10
5.1	Configuring Cartesia.....	10
5.2	Configuring the GIS gateway client.....	10
5.2.1	Object Visibility	10
5.2.2	Gazetteer.....	10
5.2.3	Screen Layout.....	10
5.2.4	Printing	10
5.2.5	Object Selection	11
5.3	Configuring the GIS gateway server	11
5.4	Extending the GIS gateway server.....	12
6.	APPLICATIONS.....	13
6.1	Intranet Applications	13
6.2	Internet applications	13
6.3	Extranet applications	14
6.4	Field applications	14
7.	FUTURE DEVELOPMENTS.....	15
8.	CONCLUSION	16

1. BACKGROUND

The utility industries are today faced with a complex business environment that is often driven by deregulation where cost reductions must be achieved simultaneously with increases in service level targets.

Within this context, companies are looking at radical business reorganisation combined with aggressive exploitation of IT as the most effective means of meeting these expectations.

A key problem with traditional IT systems is often brought about by lack of enterprise-wide integration. Typically, systems have been created and managed by specialists to perform specific departmental functions. Recent management emphasis on “business process re-engineering” has, however, focused on breaking down such departmental barriers as an important contribution to increasing efficiency and effectiveness.

GIS systems very much fall into this category; and many companies are now realising that spatial information is a resource critical to effective exploitation of IT within their organisation.

Integration of GIS systems at the enterprise level has traditionally been hampered by the lack of integration technology which is sufficiently flexible, open and powerful. This situation has, however, changed radically in the last three years with the evolution of Intranet, and three-tier architectures.

Today’s enterprise solutions for IT are centered around Intranet technology and forward thinking utilities are actively investigating and implementing their own Intranets. Some recent independent research discusses why it is important to make use of this technology and states:

“...utilities are well positioned to substantially leverage intranet technology due to the data-intensive nature of their operations. Quantitative results from the intranet Return-On-Investment study show that 80% of all companies surveyed generated a positive ROI, with an annualized return of 38%. As a group utilities returned an even higher average ROI of 80%”.

The same research goes on to state:

“Users planning to deploy engineering and operations data on intranets should focus on applications with high potential ROI, such as customer service, materials management, and database access.”¹

Intranet technologies, which include the Java language and environment as well as CORBA, are well documented elsewhere so we will not discuss these technologies here; however, their key benefits are enterprise wide integration and low cost access. For the first time, it is now possible to have a cost-effective solution that connects differing machines and systems, and provide information and applications to differing users across departmental boundaries.

¹ [META Group, Inc UTILITY INFORMATION TECHNOLOGY STRATEGIES](#)

2. PRODUCT OVERVIEW

Cartesia designates a family of Spatial Information products from Tadpole. This white paper describes the first product in the family – Cartesia Gateway, which provides desktop viewing access to GIS systems through any Web browser.

The key features of Cartesia Gateway comprise:

Portability: Cartesia works with any web browser or platform which supports the Java Virtual Machine including all flavours of UNIX and Windows, as well as the new generation of network computers and Javastations. Cartesia's CGI version provides legacy access for older desktops

Flexibility: Cartesia's core functionality provides a useful range of features including pan and zoom, client or server printing, gazetteer, object selection and querying with minimal administration overhead. Configuration and customisation to support specific applications is simple and effective.

Performance: Cartesia's thin client architecture has been optimised for high-performance even over low bandwidth lines such as GSM phones and the Internet.

Scalability: Cartesia's architecture supports and compliments Smallworld scalability and has already been deployed by utilities in multi-server configurations supporting hundreds of clients.

An example of the Cartesia User Interface is illustrated in Figure 1

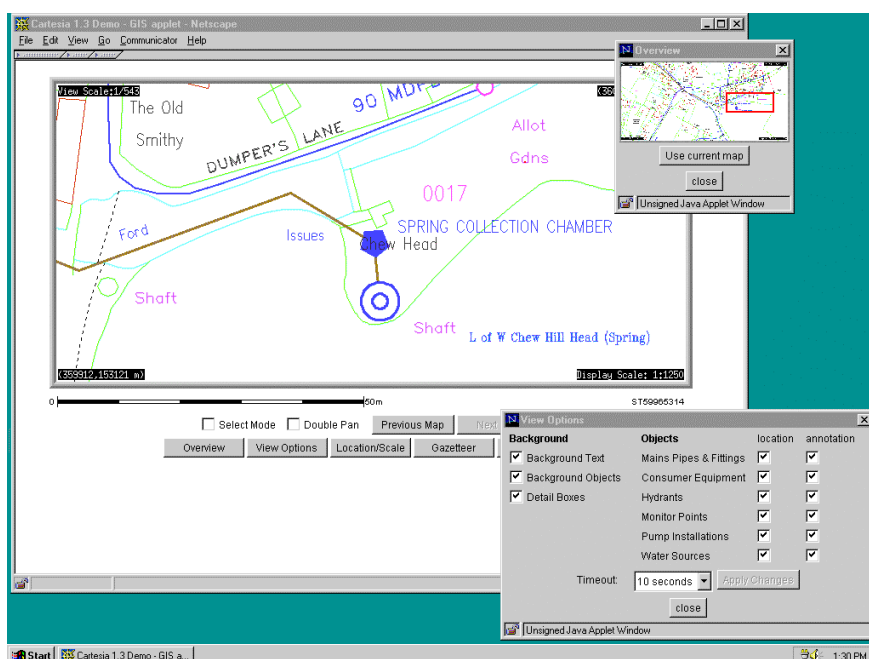

Figure 1: CARTESIA USER INTERFACE

3. DESIGN CONSIDERATIONS

Providing web-based access to geographic information is not straightforward. The requirements of web-based access to GIS present a number of complex problems.

- Ensuring timely access to data is crucial - if a result is not delivered to the browser within 8-10 seconds of it being requested, users are likely to think something is faulty at the server.
- Geographic information is potentially voluminous, so a strategy must be developed which allows the interface to still be useful even over low bandwidth connections.
- Functionality should include, at a minimum:
 - display of maps,
 - zooming and panning,
 - choosing which object categories to show,
 - examining object attributes, and
 - spatial querying (i.e. gazetteering).

3.1 CHOICE OF OPERATING ENVIRONMENT

The main advantage of web-based application deployment is the ease of maintenance and upgrade. Each desktop needs to be equipped with just a web browser and no other software. When application software is upgraded, the user need take no action to run the latest version.

Contrast this to the situation where the application lives on the desktop and hundreds, if not thousands, of machines need to have the latest version copied to their hard disk. The same problem arises if the application takes the form of a browser 'plug-in'. With a plug-in, the code must be ported to each possible target operating system and distributed to each desktop whenever changes are made.

With Java, the application can be truly system-independent, it does not need to be manually copied to each desktop and can run either as an embedded 'applet' within a web page, or as a standalone application outside of a web browser. Java is now a mature language to handle efficiently the operations required for a GIS user interface, such as complex graphics rendering and retrieval of data from the network. (The Cartesia client is written in 100% pure Java.)

The server component of Cartesia provides back-end services, including delivery of GIS data back to the client, either as sets of vectors and attributes, or as pre-rendered map tiles in GIF format. The majority of the server code is written in the Smallworld GIS Magik programming language.

3.2 CHOICE OF MAP DATA TRANSFER FORMAT

Pre-Java, the only way to provide interactive content over the web was through the use of common gateway interface (or CGI) scripts. The limitations of CGI meant that geographical information (i.e. maps) had to be delivered to the browser in one of the standard image formats, GIF or JPEG.

Providing one can generate suitable map images on the fly, it is possible (through the use of HTML tags generated by CGI scripts) to create a simple map viewer which gives users the ability to zoom, pan, customise the map and perform simple queries, without the need for a Java-enabled browser.

In order to cater for non-Java browsers, one of the services provided by the Cartesia server component is to instruct the GIS to render a map and then deliver this image to the client in GIF format. The map image is requested using a specially-constructed URL and returned using the conventional web protocol (HTTP).

The Cartesia Java client provides much greater functionality than the simple CGI interface. In addition to basic map browsing, the user can also select geographical objects (by clicking on them) and view their attributes (i.e. physical fields) in much the same way as the Smallworld 'examiner' component.

In fact many of the Java client's functions mirror those seen in a typical Smallworld application. Object selection, highlighting and attribute examination is achieved by transferring a list of vectors and attribute data from the server component back to the Java client where it can be overlaid on the main map image.

Figure 2 shows the Cartesia Object Selection user interface.

By transferring subsets of the vector data in this way, the total volume of data required to produce a useful map at the client end is greatly reduced. Data such as object view styles, vector fonts, scale dependence of object visibility and symbol sets remain at the server end and are not transferred to the client. Object attributes and geometry are transferred on demand when the user wishes to 'inspect' a particular region.

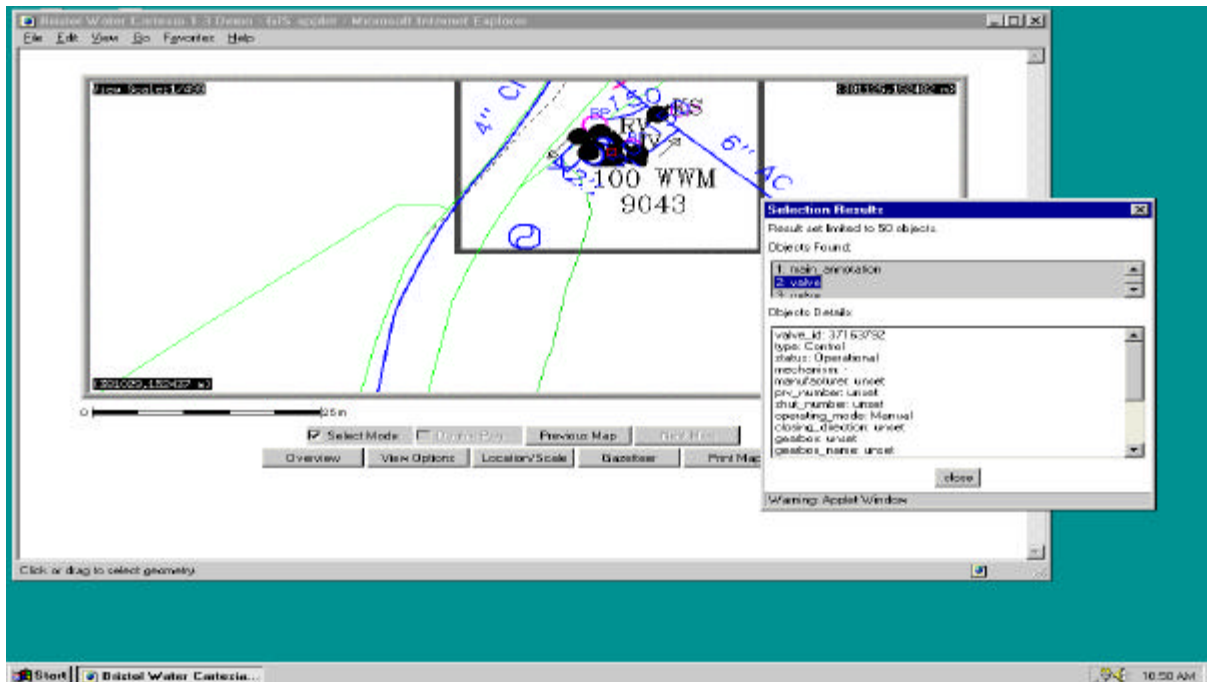

Figure 2: OBJECT SELECTION

4. PRODUCT ARCHITECTURE

The Cartesia product has a 'three-tier' architecture as shown in Figure 3. The middle tier comprises a web server, all the GIS application logic, and the Cartesia server logic. The web server delivers Java classes to active clients, as well as pre-rendered map images (in GIF format). Transfer of geometry and attribute data takes place over a separate TCP connection. The bottom tier is the spatial database which holds all geographic data for the particular application.

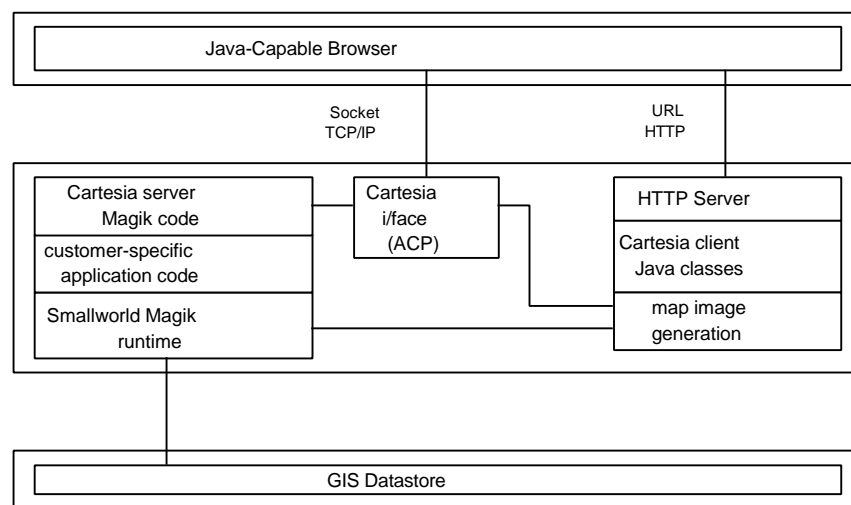

Figure 3: ARCHITECTURE OF CARTESIA FOR SMALLWORLD

The only platform specific components of the middle tier are the web server, the Cartesia interface and the image generation module. There is nothing special about the web server: any commercial or freeware server can be used, though it is preferable that the server be capable of recognising when a client aborts a connection (not all web servers can do this).

Web server performance is not critical if run on the same machine as the GIS, since the GIS itself will be using the majority of the machine's resources. Tadpole chose the CERN http daemon, which is simple, easy to configure and easy to port to other platforms.

The Cartesia interface module is a C program which communicates with the GIS via Smallworld's ACP (alien co-processor) library; it does not use Smallworld's TICS module. Its primary functions are to relay requests from Java clients to the GIS and return back result sets, to synchronise the image generation mechanism and to free GIS resources if a client connection hangs during a transaction.

The interface module is totally independent of the protocols used to transfer data between the client and the GIS. This means that the core functionality can be extended without need to modify the interface code – any new methods added to the Magik side of the application are automatically made available to the Java client.

The Cartesia Magik module provides all of Cartesia's core GIS functionality. It is supplied as Magik source code which is compiled into an existing Magik application program. The generic functionality provided by this module include:

- Rendering maps of regions of the geographic world. Support is provided for controlling which geographic object types are displayed. The default object styles and the visibility of objects at different view scales are the same as those configured for the particular GIS application.
- Returning a selection of objects and object locations that match a given search criterion. Input parameters specify the table name, which fields to match and return, the query string and cursor control (i.e. being able to return a subset of the result set, such as records 30-35 for example). This provides the necessary functionality for implementing a gazetteer at the client end.
- Plotting maps (using the Smallworld plotting system).
- A Gazetteer that is fully configurable to allow searching for any object (see Figure 4 for an illustration of the user interface).
- Returning a list of object geometries and attributes for those objects in close proximity to a given location. This gives the client end the ability to select an object with the mouse, highlight its geometry and query its attributes.
- Rollforward the database view to synchronise it with any recent changes.
- Abort - cancel any request currently in progress. This request is normally sent by the ACP interface following unexpected disconnection of a client. This allows the server to stop what it is doing and quickly get ready for the next request.

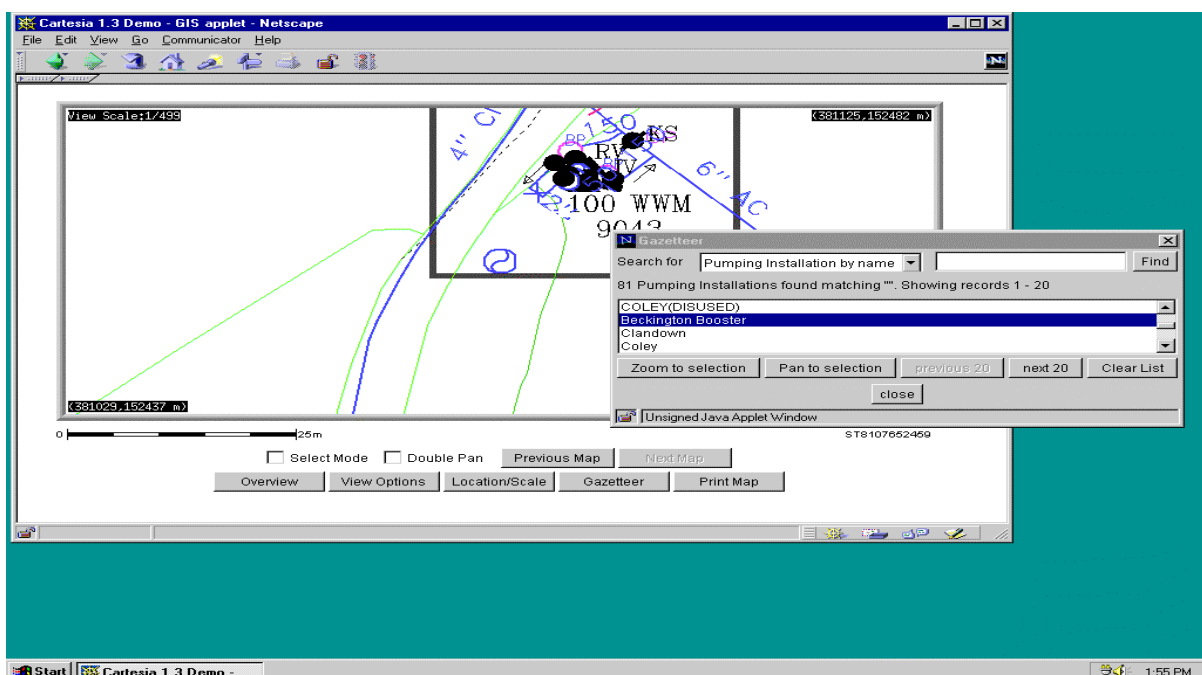

Figure 4: CARTESIA GAZETTEER FUNCTION.

Additional functions can be created (by a Magik programmer) using a Magik API provided for this purpose. Depending on the complexity, Java clients can be configured to use the new functions without the need for recompilation of the Java source code. For example, a customised gazetteer query could be written in Magik which accesses the datastore in a novel way, but shares the same user interface as the standard gazetteer.

Although the Cartesia Magik module is designed for use with a Smallworld GIS, all of the server functionality described above could be provided by a GIS from another vendor, without need to modify the client implementation.

The server can be thought of as a single user accessing the GIS whose activities are controlled remotely by other users on the network. For reasons of reliability, stateless protocols are used in the transactions that take place between the clients and the server, so that the server has no need to record any details of previous transactions. The server processes each transaction in turn one at a time.

The map image generation module is responsible for converting rendered maps to images and transferring them to the client in GIF format over an HTTP connection. This is achieved by directing all graphics output from the GIS to a 'virtual' windows system, 'grabbing' the completed image when it is ready and then compressing the image data as it is transmitted back to the client.

The Cartesia GIS server automatically detects the Smallworld version number and is compatible with Smallworld version 2.1x and 2.2x

Cartesia supports object selection and examination. When the interface is in select mode (activated by the escape button in common with a normal Smallworld session), the user clicks on the object they wish to examine. A socket connection is then established between the client and the Server ACP process which then performs a geometry scan on the GIS. The results of the geometry scanner are then returned in a popup window on the client browser and the appropriate geometry is highlighted on the map.

If multiple objects are returned by the geometry scanner, or an ambiguous selection has been made by the user, the results are still returned to the client. The user can then select which of the object details they wish to view and the resulting selection highlighted on the map.

5. CONFIGURATION & CUSTOMISATION

5.1 CONFIGURING CARTESIA

Looking at the variety of GIS applications that have been developed around the world quickly reveals that no two GIS applications are the same; the target user group, functionality and complexity of different GIS systems varies enormously. This diversity implies that any GIS Gateway must incorporate tools to configure and customise functionality.

The Cartesia GIS gateway handles these requirements via three mechanisms: configuration of the GIS gateway client, configuration of the GIS server and extension of the GIS server. The following sections describe each of these mechanisms.

5.2 CONFIGURING THE GIS GATEWAY CLIENT

The configuration of the GIS gateway client is controlled by the Client Configuration File (CCF)– an ASCII properties file downloaded from the web server with the Cartesia applet. Editing the file enables the systems administrator to change the functionality available to particular users and to determine the layout of the client GUI.

The following parameters can be controlled by the CCF:

5.2.1 Object Visibility

The ability to control the visibility of object groups is essential for enterprise GIS applications where data volumes can be extremely large. The client configuration file controls which groups of objects (and their individual fields) can be switched on and off by users. The visibility selection is constrained by the visibility options provided in the GIS; this is necessary to prevent users from selecting inappropriate object-scale combinations which might result in server overload.

5.2.2 Gazetteer

To facilitate browsing geographical information, Cartesia provides a gazetteer function. The names of the GIS tables and fields to be processed by a particular query (and the field information returned) are defined in the CCF; no additional modifications are required on the server.

5.2.3 Screen Layout

The CCF controls a number of parameters concerned with the layout of the users GUI, including the placement of screen widgets and selection of landscape or portrait options.

5.2.4 Printing

Printing options such as selection of monochrome or colour printing, scales, dots per inch, destination printer and paper size are selected in the CCF.

5.2.5 *Object Selection*

Object selection parameters such as highlight colour are selected with the CCF. To prevent unnecessary loading on the server, the maximum number of objects which can be returned to the client via the object selection is configurable. The default is to return a maximum of 50 objects.

5.3 CONFIGURING THE GIS GATEWAY SERVER

The configuration for the server side of the Cartesia gateway is also provided by an ASCII file, known as the server configuration file (SCF). The information in the SCF details the location of the Server ACP process, which GIS database partitions can be accessed, and which object fields are selected by the visibility groups defined in the CCF.

To prevent users from trying to examine inappropriate objects, such as background objects, the systems administrator can define a list of objects, which will be ignored by the object selection.

Both of the Cartesia configuration files can be configured using a GUI administration tool, which is supplied as part of the product.

5.4 EXTENDING THE GIS GATEWAY SERVER

The standard Cartesia gateway supports core GIS functionality such as zooming, panning, overview, gazetteer and object selection. There are, however, occasions when this default functionality may not be sufficient to support the application. These might include cases where web access to application specific functionality is required, either to view an existing application or as part of a new development. Additionally, there may be need to integrate client systems with other servers such as relational databases (RDBMS).

Cartesia functionality may be extended either by writing additional Magik code, by writing additional Java code, or both. The approach taken will depend on a number of factors including:

- The skill set of the developer
- The nature of the functionality required. Ideally GUI and integration issues are better addressed in Java, whilst the addition of strategic features is better done in Magik.

The object orientated approach employed during the design of Cartesia allows a developer to easily extend the Cartesia Magik code. This extension would be used to call the methods for the additional functionality in the Smallworld application. Depending on the nature of the additional functionality it may be necessary to supply further Java code for the client to view the results of the additional methods.

An alternative approach would be to “reuse” the Magik code, but extend the Java code. Developers wishing to customise Cartesia should contact Tadpole for the latest information on programming tools.

6. APPLICATIONS

6.1 INTRANET APPLICATIONS

One of the key business benefits of Cartesia is the delivery of cost-effective GIS access to any corporate desktop, laptop, network computer or high-end UNIX workstation. Traditionally, corporate GIS client software has been expensive, which has limited its use to the specialised GIS professional.

Using Cartesia, users can now gain access to corporate GIS information without this overhead. An additional advantage is that users do not need to know that they are using a GIS; spatial information can be provided as part of the total enterprise intranet and can easily be integrated with other intranet information such as phone directories, company documentation, etc.

A key advantage of Java arises from its portability and the ease with which applications can be updated. Enterprise systems typically employ many different hardware platforms and operating systems; using Java this does not pose a problem since Java runs on most systems. Similarly, if software is updated new applets are automatically downloaded to the user. For users with older desktops which do not support Java, Tadpole can provide a CGI-based version.

Cartesia is thus a powerful tool for developing the new generation of three-tier corporate Intranets. Other solutions based on proprietary solutions do not permit this flexibility. Solutions which rely on the use of plug-ins are particularly awkward to use in a corporate environment since they are very specific to particular machine configurations.

6.2 INTERNET APPLICATIONS

Although the technology is similar, Internet applications have a number of additional requirements when compared to corporate Intranets. Within a corporate environment, there is usually some conformity about desktop technology; on the open Internet, however, this is not the case and no assumptions can be made about either the hardware platform or the browser or viewer employed if the widest possible coverage is to be achieved.

A further issue is bandwidth. Internet connections usually have much lower data rates than corporate Intranets, it is therefore essential that file transfers be kept as small as possible.

Cartesia performs well in this environment:

- it transfers information primarily using the GIF format, which performs well over the Internet
- by rendering at the server, it does not require fast graphics performance at the client end
- the combination of Java with a CGI fallback works with a wide range of browsers on most hardware platforms.

6.3 EXTRANET APPLICATIONS

Extranets are essentially “closed Intranets” supporting groups of collaborating organisations and can be considered as being somewhere between Intranets and the Internet.

In terms of requirements, they are similar to those discussed in Section 6.2 although bandwidth restrictions may not be as severe.

Spatial information can support a wide range of applications within extranets. One obvious usage within the utility community derives from the need to interchange information about assets in order to support maintenance operations.

Conventional approaches which utilise paper or CD-ROM are expensive, labour intensive and can only supply information which is current at the time of issue. Using Cartesia utilities need only make their information available via the web. One UK utility is already using Cartesia for this purpose and has achieved significant cuts in IT budgets.

6.4 FIELD APPLICATIONS

Intranet technology is equally applicable to field-based systems as well as to desktop systems. Cartesia is already being used on laptops to support field service engineers and provides an easy way for engineers to access and print map information, especially out of business hours.

7. FUTURE DEVELOPMENTS

Cartesia Gateway has already been successfully deployed by a number of companies and it has proved the viability of Java-based Intranet spatial information systems. Following the introduction of Cartesia Gateway Tadpole is planning to introduce a number of new products within the Cartesia family.

The first of these new products will be a Field system, this will be an innovative product aimed at supporting field and mobile workers for utility companies. It will provide an extremely cost effective solution based on a "mobile Intranet" architecture and will include thin client hardware as well as Java software that will provide map and job data for mobile workers.

For more information on the current Cartesia products and future product plans, please contact Tadpole Technology plc.

8. CONCLUSION

The use of Java has allowed Tadpole to build a very flexible and powerful product, which performs well in a diverse range of application scenarios. Continuing exploitation of Java technology will provide important new opportunities for more effective deployment of IT.

The end result provides a very powerful open architecture for data distribution that allows utilities to leverage intranet technology in a way that should yield a significant ROI. As an example of this organisations such as ManWeb, of the Scottish Power Group, are already using Cartesia to distribute data both within and outside their own organisation with massive benefits in terms of cost savings.

In summary the intranet provides the infrastructure for cost effective data distribution and the Java architecture of Cartesia provides the powerful open platform with enormous potential for future expansion to other applications.



Tadpole Technology Plc: 137 Ditton Walk, Cambridge CB5 8FN, England
Tel: +44 1223 278200 Fax: +44 1223 278204. Email: info@tadpole.co.uk

Tadpole Technology Inc.: 12012 Technology Road, Austin, Texas 78727, USA.
Tel: National (800) 232 6656. International +1 (512) 219 2200. Fax: +1 (512) 219 2222.

Tadpole Technology Plc is a global leader in the design and manufacture of workstation-class portable computer systems as well as board-level and software products for blue-chip OEMs and end-users. A 1997 Sun Microsystems Inc, Vendor Award Winner, ISO 9001 certified Tadpole Technology has a US subsidiary in Texas and specialist distribution channels across Europe, North America and Asian/Pacific Rim.

World Wide Web: <http://www.tadpole.com>.

Customer enquiries: info@tadpole.com.