

Tru64 UNIX

Writing Kernel Modules

Part Number: AA-RHYGA-TE

July 1999

Product Version: Tru64 UNIX Version 5.0 or higher

This guide contains information needed by systems engineers to write kernel modules for the Compaq Tru64™ UNIX® (formerly DIGITAL UNIX) operating system. It includes topics useful for device driver developers who would benefit from having an intermediate layer of code between the driver software and physical devices. It would also benefit third-party developers who want to augment the kernel with modules tailored to their particular environment.

© 1999 Compaq Computer Corporation

COMPAQ, the Compaq logo, and the Digital logo are registered in the U.S. Patent and Trademark Office.

Microsoft and Windows NT are registered trademarks of Microsoft Corporation. Intel, Pentium, and Intel Inside are registered trademarks of Intel Corporation. UNIX is a registered trademark and The Open Group is a trademark of The Open Group in the US and other countries. Other product names mentioned herein may be the trademarks of their respective companies.

Possession, use, or copying of the software described in this publication is authorized only pursuant to a valid written license from Compaq Computer Corporation or an authorized sublicensor.

Compaq Computer Corporation shall not be liable for technical or editorial errors or omissions contained herein. The information in this document is subject to change without notice.

Contents

About This Manual

1 Introduction to Kernel Modules

1.1	What Is a Kernel Module?	1-1
1.1.1	Purpose of a Kernel Module	1-2
1.1.2	Kernel Module Environment	1-2
1.1.3	Designing a Kernel Module	1-5
1.2	Writing a Kernel Module — Key Tasks	1-6
1.2.1	Required Tasks	1-6
1.2.2	Additional Tasks	1-7
1.2.3	Building and Testing a Kernel Module	1-8

2 Module Initialization

2.1	The configure Routine	2-1
2.1.1	Parameters	2-2
2.1.2	Request Codes	2-3
2.1.3	Return Status Values	2-4
2.2	Module Initialization	2-4
2.2.1	Receiving the CFG_OP_CONFIGURE Request	2-5
2.2.1.1	Implementing Statically or Dynamically Loaded Kernel Modules	2-5
2.2.1.2	Checking the Configuration	2-6
2.2.1.3	Allocating Memory for Data Structures	2-7
2.2.2	Receiving the CFG_OP_UNCONFIGURE Request	2-7

3 Module Attributes

3.1	The Attribute Table	3-1
3.2	Attribute Table Entry	3-2
3.2.1	Attribute Data Types	3-3
3.2.2	Operations Allowed on an Attribute	3-3
3.3	Attribute Get Requests	3-4

3.4	Attribute Set Requests	3-6
4	Dispatch Point Callbacks	
4.1	Understanding the UNIX Boot Timeline	4-1
4.2	Why Use Callbacks?	4-2
4.3	Dispatch Points on the Boot Timeline	4-3
4.4	Implementing Callbacks in Your Kernel Module	4-4
4.4.1	Coding Callbacks	4-4
4.4.1.1	Calling the register_callback Routine	4-5
4.4.1.2	Writing the Callback Routine	4-7
4.4.2	Registering Callbacks	4-7
4.4.3	Nesting Callbacks and Deregistering Callbacks	4-8
4.4.4	Defining New Dispatch Points in your Kernel Module	4-8
5	Kernel-Mode Capabilities	
5.1	Using String Routines	5-1
5.1.1	Comparing Two Null-Terminated Strings	5-1
5.1.2	Comparing Two Strings by Using a Specified Number of Characters	5-3
5.1.3	Copying a Null-Terminated Character String	5-4
5.1.4	Copying a Null-Terminated Character String with a Specified Limit	5-5
5.1.5	Returning the Number of Characters in a Null-Terminated String	5-6
5.2	Using Data Copying Routines	5-7
5.2.1	Copying a Series of Bytes with a Specified Limit	5-7
5.2.2	Zeroing a Block of Memory	5-9
5.2.3	Copying Data from User Address Space to Kernel Address Space	5-9
5.2.4	Copying Data from Kernel Address Space to User Address Space	5-11
5.2.5	Moving Data Between User Virtual Space and System Virtual Space	5-12
5.3	Using Kernel-Related Routines	5-13
5.3.1	Printing Text to the Console and Error Logger	5-13
5.3.2	Putting a Calling Process to Sleep	5-14
5.3.3	Waking Up a Sleeping Process	5-15
5.3.4	Initializing a Timer (Callout) Queue Element	5-15
5.3.5	Removing Scheduled Routines from the Timer (Callout) Queue	5-16
5.3.6	Setting the Interrupt Priority Mask	5-17

5.3.7	Allocating Memory	5-19
5.3.7.1	Allocating Data Structures with MALLOC	5-19
5.3.7.2	Freeing Up Dynamically Allocated Memory	5-21
5.4	Working with System Time	5-21
5.4.1	Understanding System Time Concepts	5-22
5.4.1.1	How a Kernel Module Uses Time	5-22
5.4.1.2	How Is System Time Created?	5-22
5.4.2	Fetching System Time	5-23
5.4.3	Modifying a Timestamp	5-24
5.4.4	Enabling Applications to Convert a Kernel Timestamp to a String	5-25
5.4.5	Delaying the Calling Routine a Specified Number of Microseconds	5-26
5.5	Using Kernel Threads	5-26
5.6	Using Locks	5-27

6 Symmetric Multiprocessing and Locking Methods

6.1	Understanding Hardware Issues Related to Synchronization	6-1
6.1.1	Atomicity	6-2
6.1.2	Alignment	6-3
6.1.3	Granularity	6-3
6.2	Locking in a Symmetric Multiprocessing Environment	6-4
6.3	Comparing Simple Locks and Complex Locks	6-5
6.3.1	Simple Locks	6-6
6.3.2	Complex Locks	6-8
6.4	Choosing a Locking Method	6-9
6.4.1	Who Has Access to a Particular Resource	6-10
6.4.2	Prevention of Access to a Resource While a Kernel Thread Sleeps	6-10
6.4.3	Length of Time the Lock Is Held	6-10
6.4.4	Execution Speed	6-11
6.4.5	Size of Code Blocks	6-11
6.4.6	Summary of Locking Methods	6-11
6.5	Choosing the Resources to Lock in the Module	6-13
6.5.1	Read-Only Resources	6-13
6.5.2	Device Control Status Register Addresses	6-14
6.5.3	Module-Specific Global Resources	6-15
6.5.4	System-Specific Global Resources	6-16

6.5.5	How to Determine the Resources to Lock	6-17
7	Simple Lock Routines	
7.1	Declaring a Simple Lock Data Structure	7-1
7.2	Initializing a Simple Lock	7-2
7.3	Asserting Exclusive Access on a Resource	7-4
7.4	Releasing a Previously Asserted Simple Lock	7-6
7.5	Trying to Obtain a Simple Lock	7-9
7.6	Terminating a Simple Lock	7-12
7.7	Using the spl Routines with Simple Locks	7-15
8	Complex Lock Routines	
8.1	Declaring a Complex Lock Data Structure	8-1
8.2	Initializing a Complex Lock	8-2
8.3	Performing Access Operations on a Complex Lock	8-4
8.3.1	Asserting a Complex Lock	8-4
8.3.1.1	Asserting a Complex Lock with Read-Only Access	8-4
8.3.1.2	Asserting a Complex Lock with Write Access	8-7
8.3.2	Releasing a Previously Asserted Complex Lock	8-10
8.3.3	Trying to Assert a Complex Lock	8-13
8.3.3.1	Trying to Assert a Complex Lock with Read-Only Access	8-14
8.3.3.2	Trying to Assert a Complex Lock with Write Access ..	8-16
8.4	Terminating a Complex Lock	8-19
9	Kernel Threads	
9.1	Using Kernel Threads in Kernel Modules	9-1
9.1.1	Kernel Threads Execution	9-3
9.1.2	Issues Related to Using Kernel Threads	9-4
9.1.3	Kernel Threads Operations	9-4
9.2	Using the thread and task Data Structures	9-5
9.3	Creating and Starting a Kernel Thread	9-6
9.3.1	Creating and Starting a Kernel Thread at a Specified Entry Point	9-6
9.3.2	Creating and Starting a Fixed-Priority Kernel Thread Dedicated to Interrupt Service	9-9
9.4	Blocking (Putting to Sleep) a Kernel Thread	9-10
9.4.1	Asserting That the Current Kernel Thread Is About to Block Until the Specified Event Occurs	9-11
9.4.2	Using the Symmetric Multiprocessor Sleep Routine	9-14

9.5	Unblocking (Awakening) Kernel Threads	9-17
9.6	Terminating a Kernel Thread	9-19
9.7	Setting a Timer for the Current Kernel Thread	9-24

10 Building and Testing a Kernel Module

10.1	Producing a Single Binary Module	10-1
10.1.1	Step 1: Create a Directory to Contain Kernel Module Files	10-1
10.1.2	Step 2: Copy Kernel Module Files	10-2
10.1.3	Step 3: Create a BINARY.list File	10-2
10.1.4	Step 4: Run the sourceconfig Program	10-2
10.1.5	Step 5: Run the make Program	10-3
10.1.6	Step 6: Create a Kernel Configuration Development Area	10-3
10.1.7	Step 7: Run the sysconfigdb Utility	10-4
10.2	Loading and Configuring a Kernel Module	10-5
10.2.1	Loading a Module into the Kernel Image	10-5
10.2.2	Loading a Kernel Module Dynamically	10-6
10.3	Unconfiguring and Unloading Kernel Modules	10-6
10.4	Statically Configuring a Single Binary Module	10-6
10.4.1	Statically Configuring a Single Binary Module into a /vmunix Kernel	10-7
10.4.1.1	Step 1: Edit or Create the NAME.list File	10-7
10.4.1.2	Step 2: Run the doconfig Program	10-7
10.4.1.3	Step 3: Copy the New Kernel to the Root Directory ..	10-8
10.4.1.4	Step 4: Shut Down and Boot the System	10-8
10.5	Dynamically Configuring a Single Binary Module	10-8
10.5.1	Step 1: Link to the Single Binary Module	10-9
10.5.2	Step 2: Link to the Method File	10-9
10.5.3	Step 3: Run the sysconfig Utility	10-9
10.6	Creating the sysconfigtab File Fragment	10-9
10.7	Changing Attribute Values at Run Time	10-12

10.8	Testing a Kernel Module	10-12
------	-------------------------------	-------

Glossary

Index

Examples

10-1	A sysconfigtab File Fragment	10-11
------	------------------------------------	-------

Figures

1-1	Kernel Module Environment	1-3
3-1	Attribute Get Requests	3-5
3-2	Attribute Set Requests	3-7
4-1	Dispatch Points Along the Boot Timeline	4-2
4-2	Using the Kernel Callback Subsystem	4-5
5-1	Results of the strcmp Routine	5-2
5-2	Results of the strncmp Routine	5-4
5-3	Results of the strcpy Routine	5-5
5-4	Results of the strncpy Routine	5-6
5-5	Results of the strlen Routine	5-7
5-6	Results of the bcopy Routine	5-8
5-7	Results of the copyin Routine	5-10
5-8	Results of the copyout Routine	5-12
5-9	When Time Becomes Available During a System Boot	5-23
6-1	Why Locking Is Needed in an SMP Environment	6-5
6-2	Simple Locks Are Spin Locks	6-6
6-3	Complex Locks Are Blocking Locks	6-8
7-1	Two Instances of the xx Module Asserting an Exclusive Lock	7-6
7-2	One Instance of the xx Module Releasing an Exclusive Lock	7-9
7-3	The xx Module Trying to Assert an Exclusive Lock	7-12
8-1	Three Instances of the if_fta Module Asserting a Read-Only Complex Lock	8-7
8-2	Three Instances of the if_fta Module Asserting a Write Complex Lock	8-10
8-3	One Instance of the if_fta Module Releasing a Complex Write Lock	8-13
8-4	The if_fta Module Trying to Assert a Complex Read-Only Lock	8-16
8-5	The if_fta Module Trying to Assert a Complex Write Lock	8-19

9-1	Using Kernel Threads in a Kernel Module	9-3
10-1	Format of the sysconfigtab File Fragment	10-10

Tables

5-1	Uses for spl Routines	5-17
6-1	Data Structure and Routines Associated with Simple Locks	6-7
6-2	Data Structure and Routines Associated with Complex Locks	6-9
6-3	SMP Characteristics for Locking	6-12
6-4	Kernel Module Resources for Locking	6-17
6-5	Locking Device Register Offset Definitions	6-19
9-1	Summary of Operations That Kernel Thread Routines Perform	9-5

About This Manual

This book discusses topics related to writing kernel modules for computer systems running the Compaq Tru64™ UNIX® (formerly DIGITAL UNIX) operating system.

Audience

This book is intended for systems engineers who:

- Understand the design and implementation of the Tru64 UNIX operating system and desire to enhance the functionality of the `/vmunix` kernel with kernel modules that they write
- Understand the basics of the CPU hardware architecture, including interrupts, direct memory access (DMA) operations, and I/O
- Use standard library routines to develop programs in the C language
- Know the Bourne or some other shell based on the UNIX operating system
- Understand basic UNIX operating system concepts, such as kernel, shell, process, configuration, and autoconfiguration
- Understand how to use the Tru64 UNIX programming tools, compilers, and debuggers
- Develop programs in an environment that involves dynamic memory allocation, linked list data structures, and multitasking

This book assumes that you have a strong background in operating systems based on the UNIX operating system. It also assumes that you have a strong background in systems and C programming. In addition, the book assumes that you have no source code licenses.

New and Changed Features

Writing Kernel Modules is a new book. However, it contains information incorporated from the last released version of *Writing Device Drivers: Advanced Topics*. The following list summarize changes and additions made since the last release of *Writing Device Drivers: Advanced Topics*:

- New chapters on module initialization, module attributes, dispatch point callbacks, kernel-mode capabilities, and building kernel modules have been added.
- Information on locking mechanisms and kernel threads has been revised.
- Device driver–specific information previously in *Writing Device Drivers: Advanced Topics* has been moved to the *Writing Device Drivers* book, including:
 - Using interfaces related to the I/O handle
 - Using funnels
 - Writing a disk device driver

Scope of the Book

This book is for users of the Tru64 UNIX operating system on computer systems developed by Compaq Computer Corporation. It describes how to develop a kernel module and presents examples where kernel modules can be used. The book also presents examples that show how to use routines associated with symmetric multiprocessing and kernel threads.

The book assumes that you are new to writing kernel modules but may have experience writing device drivers or programming in the UNIX kernel.

Organization

The book contains the following chapters:

Chapter 1	<p>Introduction to Kernel Modules</p> <p>Provides an overview of the chapters in this book. Defines kernel modules, presents a high-level model for using kernel modules, presents reasons for writing a kernel module, and describes general rules for writing a kernel module.</p>
Chapter 2	<p>Module Initialization</p> <p>Describes how to initialize a kernel module using the <code>configure</code> routine.</p>
Chapter 3	<p>Module Attributes</p> <p>Describes setting module attributes and the module attribute table.</p>

Chapter 4	Dispatch Point Callbacks Describes the boot timeline and how to implement callbacks in a kernel module.
Chapter 5	Kernel-Mode Capabilities Describes programming capabilities available in kernel mode.
Chapter 6	Symmetric Multiprocessing and Locking Methods Provides an overview of the SMP environment, including guidelines for selecting a locking method.
Chapter 7	Simple Lock Routines Describes how to define and use simple locks in an SMP environment.
Chapter 8	Complex Lock Routines Describes how to define and use complex locks in an SMP environment.
Chapter 9	Kernel Threads Provides an introduction to multithreaded programming for kernel modules and discusses using kernel threads.
Chapter 10	Building and Testing a Kernel Module Describes key steps for creating a single binary module (.mod file) and testing the module.

Related Documentation

The printed version of the Tru64 UNIX documentation uses letter icons on the spines of the books to help specific audiences quickly find the books that meet their needs. (You can order the printed documentation from Compaq.) The following list describes this convention:

- G Books for general users
- S Books for system and network administrators
- P Books for programmers

- D Books for device driver writers
- R Books for reference page users

Some books in the documentation help meet the needs of several audiences. For example, the information in some system books is also used by programmers. Keep this in mind when searching for information on specific topics.

The *Documentation Overview* provides information on all of the books in the Tru64 UNIX documentation set.

Writing kernel modules is a complex task; writers require knowledge in a variety of areas. One way to acquire this knowledge is to have at least the following categories of documentation available:

- Hardware documentation
- Bus-specific device driver documentation
- Operating system overview documentation
- Programming tools documentation
- Network programming documentation

The following sections list the documentation associated with each of these categories.

Hardware Documentation

If your kernel module is a device driver, you should have available the hardware manual associated with the device for which you are writing the module. You should also have access to the manual that describes the architecture associated with the CPU on which the driver operates, for example, the *Alpha Architecture Reference Manual*.

Bus-Specific Device Driver Documentation

Writing Device Drivers is the core book for developing device driver kernel modules on the Tru64 UNIX Version 5.0 operating system. It contains information needed for developing modules on any bus that operates on Compaq platforms.

Reference Pages, Section 9r, Device Drivers (Volume 1) and *Reference Pages, Section 9s, 9u, and 9v, Device Drivers (Volume 2)* describe the routines, data structures, and global variables that device drivers use.

The following books provide information about writing device drivers for a specific bus:

- *Writing EISA and ISA Bus Device Drivers*

This manual provides information for systems engineers who write device drivers for the EISA/ISA bus. The manual describes EISA/ISA bus-specific topics, including EISA/ISA bus architecture and data structures that EISA/ISA bus device drivers use.

- *Writing PCI Bus Device Drivers*

This manual provides information for systems engineers who write device drivers for the PCI bus. The manual describes PCI bus-specific topics, including PCI bus architecture and data structures that PCI bus device drivers use.

- *Writing Device Drivers for the SCSI/CAM Architecture Interfaces*

This manual provides information for systems engineers who write device drivers for the SCSI/CAM Architecture routines. The manual provides an overview of the Tru64 UNIX SCSI/CAM Architecture and describes User Agent routines, data structures, common and generic routines and macros, error handling, and debugging routines. The manual includes information on configuration and installation. examples show how programmers can define SCSI/CAM device drivers and write to the SCSI/CAM special I/O routine that the operating system supplies to process special SCSI I/O commands.

- *Writing TURBOchannel Device Drivers*

This manual contains information systems engineers need to write device drivers that operate on the TURBOchannel bus. The manual describes TURBOchannel-specific topics, including TURBOchannel routines that TURBOchannel device drivers use.

- *Writing VMEbus Device Drivers*

This manual contains information systems engineers need to write device drivers that operate on the VMEbus. The manual describes VMEbus-specific topics, including VMEbus architecture and routines that VMEbus device drivers use.

Operating System Overview Documentation

Refer to the *Technical Overview* for a technical introduction to the Tru64 UNIX operating system.

This manual provides a technical overview of the Tru64 UNIX system, focusing on the networking subsystem, the file system, virtual memory, and the development environment. This manual does not supersede the Software Product Description (SPD), which is the definitive description of the Tru64 UNIX system.

Programming Tools Documentation

To create your kernel modules, you use a number of programming development tools and should have on hand the manuals that describe how to use these tools. The following manuals provide information related to programming tools used in the Tru64 UNIX operating system environment:

- *Kernel Debugging*

This manual provides information about debugging kernels. The manual describes using the `dbx`, `kdbx`, and `kdebug` debuggers to find problems in kernel code. It also describes how to write a `kdbx` utility extension and how to create and analyze a crash dump file. This manual is for system administrators responsible for modifying, rebuilding, and debugging the kernel configuration. It is also for system programmers who need to debug their kernel space programs.

- *Programming Support Tools*

This manual describes several commands and utilities in the Tru64 UNIX system, including facilities for text manipulation, macro and program generation, and source file management. The commands and utilities described in this manual are primarily for programmers, but some of them (such as `grep`, `awk`, `sed`, and the Source Code Control System (SCCS)) are useful for other users. This manual assumes that you are a moderately experienced user of UNIX systems.

- *Programmer's Guide*

This manual describes the programming environment of the Tru64 UNIX operating system, with an emphasis on the C programming language. This manual is for all programmers who use the Tru64 UNIX operating system to create or maintain programs in any supported language.

System Management Documentation

Refer to the *System Administration* manual for information about building a kernel and for general information on system administration.

This manual describes how to configure, use, and maintain the Tru64 UNIX operating system. It includes information on general day-to-day activities and tasks, changing your system configuration, and locating and eliminating sources of trouble. This manual is for the system administrators responsible for managing the operating system. It assumes a knowledge of operating system concepts, commands, and configurations.

Reader's Comments

Compaq welcomes any comments and suggestions you have on this and other Tru64 UNIX manuals.

You can send your comments in the following ways:

- Fax: 603-884-0120 Attn: UBPG Publications, ZKO3-3/Y32
- Internet electronic mail: `readers_comment@zk3.dec.com`

A Reader's Comment form is located on your system in the following location:

```
/usr/doc/readers_comment.txt
```

- Mail:

Compaq Computer Corporation
UBPG Publications Manager
ZKO3-3/Y32
110 Spit Brook Road
Nashua, NH 03062-9987

A Reader's Comment form is located in the back of each printed manual. The form is postage paid if you mail it in the United States.

Please include the following information along with your comments:

- The full title of the book and the order number. (The order number is printed on the title page of this book and on its back cover.)
- The section numbers and page numbers of the information on which you are commenting.
- The version of Tru64 UNIX that you are using.
- If known, the type of processor that is running the Tru64 UNIX software.

The Tru64 UNIX Publications group cannot respond to system problems or technical support inquiries. Please address technical questions to your local system vendor or to the appropriate Compaq technical support office. Information provided with the software media explains how to send problem reports to Compaq.

Conventions

This book uses the following conventions:

- A vertical ellipsis indicates that a portion of an example that would normally be present is not shown.

...	In syntax definitions, a horizontal ellipsis indicates that the preceding item can be repeated one or more times.
<i>file</i>	Italic type indicates variable values, placeholders, and function argument names.
buf	In function definitions and syntax definitions used in module configuration, this typeface is used to indicate names that you must type exactly as shown.
[]	In formal parameter declarations in function definitions and in structure declarations, brackets indicate arrays. Brackets are also used to specify ranges for device minor numbers and device special files in file fragments. However, for syntax definitions, these brackets indicate items that are optional.
	Vertical bars separating items that appear in syntax definitions indicate that you choose one item from among those listed.

Introduction to Kernel Modules

This chapter presents an overview of kernel modules by discussing the following topics:

- Definition of kernel module
- Purpose of a kernel module
- The kernel module environment
- Designing a kernel module
- Writing a kernel module

1.1 What Is a Kernel Module?

A **kernel module** is a binary image containing code and data structures that runs in the UNIX kernel. It has the following characteristics:

- Is statically loaded as part of `/vmlinuz` or dynamically loaded into memory
- Runs in kernel mode
- Has a file name ending with the extension `.mod`
- Contains a well-defined routine that executes first to initialize the module
- May be a device driver when it performs any one of these additional tasks:
 - Handles interrupts from hardware devices
 - Accepts I/O requests from applications

The kernel contains many modules, some of which are device drivers. In this book, a kernel module is defined more broadly than a device driver because it can be used to perform a variety of functions, including:

- Management functions
- Common functions shared by other modules

1.1.1 Purpose of a Kernel Module

The kernel consists of a set of kernel modules that interact with each other, each performing a specific function. Some kernel modules perform software functions exclusively, while others (such as device drivers) control the operation of system hardware components.

A purpose for writing a kernel module is to provide a middle layer of code, or common code, thus increasing the efficiency of your system by combining like tasks in a single area and eliminating redundant code.

For example, assume you need to write a SCSI driver for disk and tape peripheral devices. You could write two **monolithic drivers**—one for each hardware device—but this would mean replicating a majority of the code, while only a small amount would differ. By writing a kernel module containing common code, you eliminate this redundancy (see Figure 1–1). One class driver might handle SCSI tapes and another handle SCSI disks. Both call the kernel module, which sends the I/O request to a variety of port drivers. The port drivers send requests to the SCSI controller. As you add more disk or tape drives to your system, the kernel module would seamlessly manage the expansion, while controller-specific code would be confined to the new port drivers. Similarly, you can add a different SCSI device (for example, a scanner) by writing a new class driver. The kernel module would maintain a consistent interface to the other kernel modules and make adding the new driver easier.

1.1.2 Kernel Module Environment

Figure 1–1 shows a kernel module in relationship to other modules in the kernel. As a binary image, a kernel module can be loaded statically as part of `/vmmunix` or dynamically loaded into memory. In this example, the kernel module is part of a driver subsystem.

Figure 1–1: Kernel Module Environment

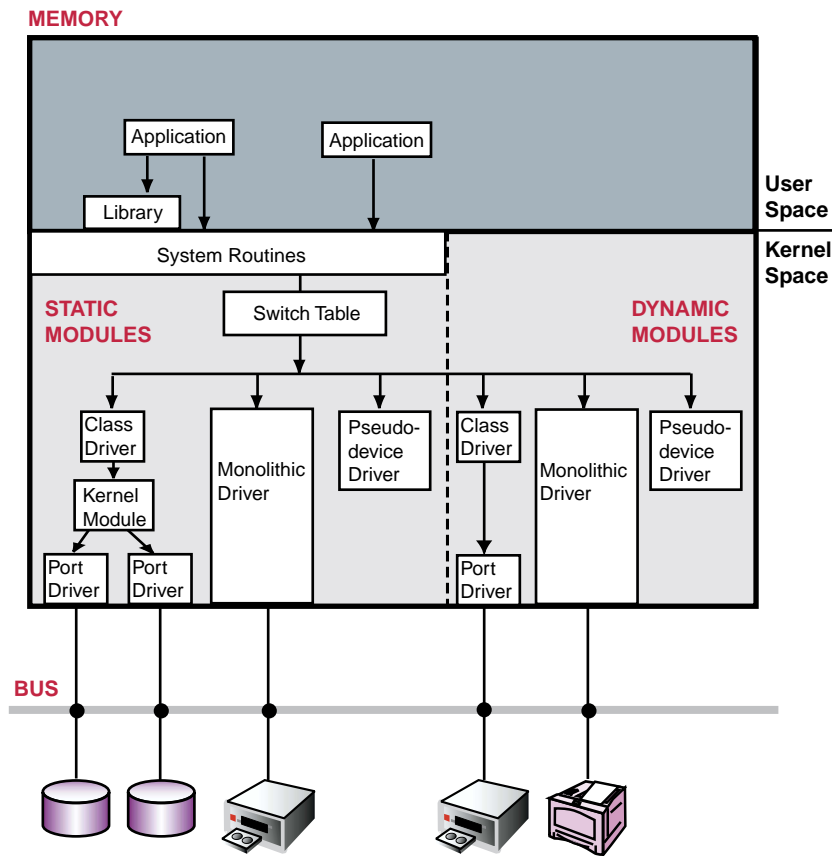

ZK-1539U-AI

The following list describes the main components in Figure 1–1.

Application

A user-mode program that, in the context of this book, makes various requests to the kernel modules. If a kernel module is part of a device driver, these requests typically perform I/O operations to hardware components. Another term for application is utility.

Bus

A hardware component that connects multiple buses and controllers to the system.

Class/Port Driver

The class/port driver comprises two drivers. The class driver supports user interfaces while the port driver supports the hardware and handles interrupts. The driver model is always made of more than one module and it can have multiple class drivers, multiple port drivers, and some common code in a middle layer. The structure of this driver eliminates code duplication.

Controller

A hardware component that performs a specific function, such as communicate on the network or control the graphics monitor.

Device

A hardware component that is connected to a controller.

Device Driver

A kernel module that supports one or more hardware components. There are two driver models: the monolithic driver model and the class/port driver model.

Interrupt

A signal from a hardware component that eventually causes the interrupt handler in the appropriate driver to be called.

Kernel Module

A `.mod` file residing in the kernel that executes common code. In Figure 1-1, the kernel module is part of a device driver.

Kernel Space

Activities that happen within the UNIX kernel. Modules may be statically loaded as part of `/vmunix` or dynamically loaded as needed. The **module framework**, which in Figure 1-1 can be thought of as the background area of kernel space, loads, unloads, makes management requests, and keeps track of the modules in kernel space.

Library

User-mode code that is called by applications. Libraries contain routines that perform common functions used by many applications.

Monolithic Driver

Kernel module code that is all-inclusive; supporting everything from user requests to processing interrupts from hardware.

Pseudodevice driver

A pseudodevice driver, such as the `pty` terminal driver, structured like other drivers but not operating on a bus and not controlling hardware. A pseudodevice driver does not register itself in the hardware topology (system configuration tree). Instead, it relies on the device driver method of the `cfgmgr` framework to create the associated device special files.

Switch Table

A data structure in the kernel where the block and character I/O interface entry points are stored.

System Routines

Routines in the kernel that can be called from user mode (applications and libraries).

User Space

User application level or command-line interface to the operating system.

1.1.3 Designing a Kernel Module

The following are guidelines for you to consider when designing your kernel module:

- A kernel module is best written as a **single binary image** that can be statically loaded as part of `/vmunix` or dynamically loaded into memory.
- When you write your kernel module, it is important to design your code correctly with regard to **dispatch points** along the **boot timeline**. These are points along the boot path (timeline) that are reached as the operating system boots. When a dispatch point is reached, certain things are configured and made available. As a single binary image, your kernel module can be statically loaded as part of `/vmunix` or dynamically loaded into memory, therefore any callbacks you register must reflect the proper order of dispatch along the boot timeline (see Chapter 2).
- If you support dynamically loaded kernel modules, plan to write features that support dynamic unloading as well, for these reasons:

- Unloading a module will free up resources.
- Dynamic unloading allows you to replace an old version of a kernel module with a new version without rebooting.

1.2 Writing a Kernel Module — Key Tasks

This book is organized so that key tasks for writing a kernel module are logically grouped:

- Section 1.2.1 describe tasks that all kernel module writers need to perform to develop a kernel module.
- Section 1.2.2 describes optional tasks for writers whose modules run in an SMP environment or use kernel threads.
- Section 1.2.3 describes building and testing tasks that pertain to all kernel module writers.

1.2.1 Required Tasks

All kernel module writers need to understand module initialization, creating the module attribute table, using callbacks, and working in kernel mode. The following sections describe these tasks.

Initializing a Kernel Module

Kernel module **initialization** occurs in both **static** and **dynamic** mode. Kernel module writers must understand the concept of a single binary image, the build-load-initialize sequence, and how to use the `configure` routine to perform initialization tasks to add a kernel module (make it known to the kernel) or to remove it. Chapter 2 describes these concepts and the required tasks for coding your kernel module to initialize properly. It also describes how to unload dynamically loaded modules.

Creating the Attribute Table

All kernel modules must contain an **attribute table**. Chapter 3 describes a variety of tasks you can perform on the module attribute table to retrieve data from the table and set data in the table.

Using Callbacks

Kernel modules contain one or more callback routines that perform different aspects of initialization along the boot timeline. Coding **callback** routines in a kernel module is a key task for creating a kernel module that may function as a single binary image. Chapter 4 describes the rules for using callbacks in a kernel module. It discusses callbacks in relation to

dispatch points along the boot timeline, and how the kernel calls the kernel module's callback routine.

Working in Kernel Mode

You can perform many tasks in kernel mode. Chapter 5 describes how to:

- Work with string routines
- Use data copying routines
- Use kernel-related routines
- Work with system time
- Use kernel threads
- Use locks

1.2.2 Additional Tasks

If your kernel module executes in a **symmetric multiprocessing** (SMP) environment or uses kernel threads, you must perform additional tasks, as described in the following sections.

Working in an SMP Environment

Selecting a locking methodology and coding the correct type of lock in your kernel module are key tasks for writing kernel modules that execute in an SMP environment. Chapter 6 through Chapter 8 describe how to:

- Choose a locking methodology
- Use **simple lock** routines
- Use **complex lock** routines

Working with Kernel Threads

Chapter 9 describes the key concepts and tasks for developing kernel modules that use **kernel threads**. These include:

- Advantages of using kernel threads
- Kernel threads operations
- Kernel threads data structures
- Creating, starting, blocking, unblocking, and terminating thread processes

1.2.3 Building and Testing a Kernel Module

After you have written your kernel module, the next task is to build the executable module (a `.mod` file) and test it. Chapter 10 walks you through steps to build and test your kernel module.

2

Module Initialization

Kernel module initialization refers to the tasks necessary to incorporate a kernel module into the kernel and make it available for use by the system. After you write your kernel module, you create a single binary image (a file with the `.mod` extension) from the kernel module source file (usually a C file). This file is loaded into memory and its `configure` routine is called to perform initialization. Module initialization consists primarily of allocating and initializing data structures and calling on other kernel modules to tell them that your module is loaded and available.

The `configure` routine manages initialization. This chapter describes how this routine performs a variety of initialization tasks, including:

- Initializing the kernel module at system startup or at run time
- Preparing the kernel module for removal from the system

Other requests to the `configure` routine, such as reconfiguring the kernel module when an attribute value changes and returning information from the attribute table, are covered in Chapter 3.

2.1 The `configure` Routine

The `configure` routine handles requests targeted at the kernel module and performs the required actions. The `configure` routine's structure is the same for all kernel modules, regardless of the function they perform and whether or not the kernel module is a device driver.

The naming convention for the `configure` routine requires that the name of the routine be the module name followed by `_configure`. This allows the module framework to locate the routine and call it. For example, for the kernel module `example.mod`, the `configure` routine would be named `example_configure`.

Note that if your module does not contain a properly named `configure` routine, one of the following conditions will occur:

- For statically loaded modules, the `/vmunix` kernel will not be able to build.
- For dynamically loaded modules, the module will not be able to load into memory.

2.1.1 Parameters

The `configure` routine accepts the following parameters:

`op` (`cfg_op_t`)

The module framework sets this parameter to one of several request codes that describe the operation the module should perform:

- Initialize the module – `CFG_OP_CONFIGURE`
- Obtain attribute values – `CFG_OP_QUERY`
- Change attribute values – `CFG_OP_RECONFIGURE`
- Prepare the module for unloading – `CFG_OP_UNCONFIGURE`

These operations are described in Section 2.1.2.

`indata` (`cfg_attr_t`)

Specifies a pointer to an array of data structures that contain information about the attributes in your kernel module attribute table, plus status information. The module framework checks the validity of attribute values when it copies attributes into memory, and it sets the status to indicate whether the value passes those tests.

`indatalen` (`size_t`)

Specifies the number of structures in the `indata` array.

`outdata` (`cfg_attr_t`)

Specifies a pointer to a module-specific output data structure when the `op` parameter specifies a subsystem-defined operation. Otherwise, its value is `NULL`.

`outdatalen` (`size_t`)

Specifies the size of the `outdata` parameter in bytes.

Typically, the `configure` routine is written as a `switch` statement, with one `case` statement to handle each operation.

For example:

```
int example_configure (cfg_op_t op,
                      cfg_attr_t *indata,
                      size_t indatalen,
                      cfg_attr_t *outdata,
                      size_t outdatalen)
{
    int status;.
    :
    switch(op) {
        case CFG_OP_CONFIGURE:
```

```

        status=value;
        :
        :
        break;
case CFG_OP_QUERY:
    status=value;
    :
    :
    break;
case CFG_OP_UNCONFIGURE:
    status=value;
    :
    :
    break;
case CFG_OP_RECONFIGURE:
    status=value;
    :
    :
    break;
default:
    status=ENOTSUP;
    break;
}

return (status);
}

```

The ENOTSUP error return value indicates that the kernel module does not support the requested operation. Otherwise, the routine returns a status value appropriate for the request. (See Section 2.1.3 for information on return status values.)

2.1.2 Request Codes

The `configure` routine accepts several parameters (see Section 2.1.1 for a list of all parameters accepted by the `configure` routine). The `op` parameter takes one of the following request codes, which describe the specific operation the module should perform:

- `CFG_OP_CONFIGURE`

When the module framework calls the `configure` routine with the `CFG_OP_CONFIGURE` request code, the kernel module begins initialization. In this way, the `configure` routine functions similarly to the `main()` routine in a user program. Your kernel module must be initialized whether it is loaded dynamically or statically. Section 2.2.1 describes this operation in more detail.

- `CFG_OP_QUERY`

This request code retrieves values of attributes defined in the module attribute table. The kernel module should initialize the values of attributes stored in the module attribute table so that the proper values are retrieved. (See Chapter 3 for more information.)

- `CFG_OP_RECONFIGURE`

This request code specifies that values for some attributes in the module attribute table have been set and that the kernel module should operate based on changes to the values of the attributes. (See Chapter 3 for more information.)

- `CFG_OP_UNCONFIGURE`

This request code specifies that an attempt to unload your module has been requested, which will result in either module cleanup or a return error. In effect, this request asks your module to undo the initialization tasks performed in `CFG_OP_CONFIGURE` and prepare it for removal from the system. (See Section 2.2.2 for more information.)

2.1.3 Return Status Values

The `configure` routine may return any standard status value from the file `/usr/include/errno.h` as an `int` to the module framework. The following list defines the most common return status values:

- `ESUCCESS` – Indicates success.
- `ENOMEM` – Indicates insufficient memory.
- `ENOTSUP` – Indicates that the operation is not supported.
- `ENOSYS` – Indicates that the operation is not supported at this time. It may have been called too early and is supported later in the boot timeline.
- `EINVAL` – Indicates that an unrecognized parameter was passed (for example, `indata`, `indatalen`).

The return status value is later appended to the higher 16 bits of a final return that is returned to the caller. The module framework status resides in the lower 16 bits of the return status.

2.2 Module Initialization

Before a kernel module can be useful, it typically needs to initialize data structures and let other kernel modules know that it exists and is available. The module framework calls the `configure` routine with the `CFG_OP_CONFIGURE` request code to alert the module to perform initialization. Likewise, the module framework passes the `CFG_OP_UNCONFIGURE` request code to alert the kernel module to prepare for removal from the system. These codes are described in detail in the following sections.

2.2.1 Receiving the CFG_OP_CONFIGURE Request

The module framework calls the `configure` routine with the `CFG_OP_CONFIGURE` request code to request that the module perform its one-time initialization. This is always the first call into the module, regardless of whether it is statically or dynamically loaded. If the kernel module is statically loaded, the module framework calls the `configure` routine very early in the boot timeline. Because of this, the kernel module typically registers callback routines to execute immediately or at specific dispatch points to perform initialization tasks. These tasks include:

- Allocating data structures
- Initializing locks
- Starting kernel threads
- Registering with other subsystems

When you code your kernel module initialization process using callbacks, the result is a single binary image that can be loaded statically or dynamically. Otherwise, your kernel module will be either a static module or a dynamic module, but not both. Chapter 4 expands on this concept by discussing the relationship between callbacks and dispatch points. The following sections present further considerations for modules that are loaded either statically or dynamically.

2.2.1.1 Implementing Statically or Dynamically Loaded Kernel Modules

When a kernel module is statically loaded, it is linked as part of `/vmunix` and loaded into memory as part of the kernel. The module framework must call the `configure` routine with the `CFG_OP_CONFIGURE` request code before memory can be allocated, locks can be used, and subsystems can be used. As a result, a statically loaded module typically is not able to perform initialization when its `configure` routine is called with the `CFG_OP_CONFIGURE` request code. Instead, it registers callbacks that are invoked when these resources become available as the system boots. In contrast, a dynamically loaded module is linked as its own image and loaded into memory on its own. If you used callbacks in a dynamically loaded module, the initialization still occurs properly.

To overcome the problem of resources not being available for a statically loaded module, the `configure` routine registers callback routines to be called at specific dispatch points, as described in Chapter 4. Initialization takes place when these callback routines are called. Callbacks enable your module to be a single binary image that can be statically or dynamically loaded.

2.2.1.2 Checking the Configuration

To handle initialization correctly, whether your module is statically loaded or dynamically loaded, global variables keep track of the following information:

- Whether the kernel module has already been initialized

A kernel module receives the `CFG_OP_CONFIGURE` request code only once. Therefore, you define a global variable to keep track of this information and set the variable's initial value to `FALSE`. When the `configure` routine successfully accepts the `CFG_OP_CONFIGURE` request, set this value to `TRUE`. For example, for a kernel module named `example.mod`, the module defines the `example_config` global variable as follows to indicate whether the module has been initialized:

```
int example_init_config = FALSE;
```

- Whether the module was dynamically or statically loaded

The module framework returns the current configuration state when you call the `cfgmgr_get_state` routine. The `cfgmgr_get_state` routine returns `SUBSYSTEM_STATICALLY_CONFIGURED` if the module was statically loaded. It returns

`SUBSYSTEM_DYNAMICALY_CONFIGURED` if the module was dynamically loaded. Your module can call this routine if it needs to know how it was loaded. Typically, a kernel module should be written such that it does not need to call this routine.

- Whether the module's callback routines completed successfully

When the kernel module is configured at startup, callback routines run at different times along the boot timeline. Therefore, global variables are the only way to communicate the success or failure of the callback routines. For example, you would not want to perform any postconfiguration operations if the preconfiguration callback routine failed.

In this example, the following global variable is defined to hold the callback status:

```
int example_initied=EFAIL;
```

Note that the global variable is defined with an error status. When the kernel module is loaded, the callback routine has not yet been called. The callback routine stores its status in this global variable before it returns to the caller. This status is available to the remainder of the source code in the module for the purpose of checking the callback routine status (that is, it checks if the module has been successfully initialized).

2.2.1.3 Allocating Memory for Data Structures

Your kernel module may need to allocate memory for data structures during initialization. You must wait until the `CFG_PT_VM_AVAIL` dispatch point occurs. When you are ready to allocate memory, you use the `MALLOC` macro. (Use the `FREE` macro to deallocate memory.) See Section 5.3.7 for more information about allocating memory.

2.2.2 Receiving the `CFG_OP_UNCONFIGURE` Request

The module framework calls the `configure` routine with the `CFG_OP_UNCONFIGURE` request code to have both statically loaded and dynamically loaded kernel modules prepare to go off line. When modules are brought off line, they are not available for use by any other module in the kernel. Only dynamically loaded kernel modules can actually be unloaded. Statically loaded modules remain loaded once they are brought off line. (See Section 2.2.1.2 to determine how the kernel module was loaded.)

When a module (static or dynamic) has successfully gone off line, it should return `ESUCCESS`.

To prepare to go off line, the kernel module must accomplish the following tasks before returning a success status value to the module framework:

- Deallocate all data structures
- Deinitialize locks
- Terminate all kernel threads
- Deregister with other kernel subsystems

A kernel module (static or dynamic) can determine that it cannot be unloaded. In this case, the module should return an error to the module framework to keep it from attempting to unload the module.

Module Attributes

This chapter describes the module attribute table and the operations that can be performed on it to:

- Retrieve data from the table
- Set data in the table

It also describes entries in the table and how to manipulate the values of the attributes.

3.1 The Attribute Table

Every kernel module must have one attribute table that defines some of the data for the kernel module. The system administrator can use settable attributes in the attribute table to tune the module.

Note

If your kernel module does not have any defined attributes, you are still required to provide an attribute table with one terminating NULL entry.

The name of the attribute table is the module name followed by `_attributes`. For example, for the `example.mod` kernel module, the attribute table would be named `example_attributes`.

The attribute table is an array of the data structure `cfg_subsys_attr_t` (defined in `/usr/include/sys/sysconfig.h`). Each `cfg_subsys_attr_t` data structure defines an attribute for your module. There are no required attributes for this table.

A **attribute table entry** comprises one instance of the `cfg_subsys_attr_t` data structure. The last table entry must be all zeros. Section 3.2 describes the fields in an attribute table entry.

3.2 Attribute Table Entry

An attribute table entry is one instance of the `cfg_subsys_attr_t` data structure. An entry is composed of many fields, defined in the following list:

- `addr` (`caddr_t`)

Specifies the kernel address of the location holding the value of the attribute. Using this address, the module framework returns the attribute's value during a `CFG_OP_QUERY` request and changes the value with a `CFG_OP_RECONFIGURE` request. As a result, the `configure` routine does not need to do additional processing. If you do not provide an address, the `configure` routine must separately handle value retrieval and deposit.

Note that if the attribute supports the `CFG_OP_CONFIGURE` or `CFG_OP_RECONFIGURE` request operation, then the address given in this field must be a writable location. That is, it cannot be a location of the type `const`.

- `name` (`char`)

Specifies the ASCII name of the attribute. The name must be between two and `CFG_ATTR_NAME_SZ` characters in length, including the terminating null character.

To create a name for your attribute, follow these conventions:

- Use lowercase letters, unless capitals make better sense (for example, when using an acronym in the attribute name, such as `MAC_address`).
- Use an underscore to separate parts of the name.
- Create intuitive names; do not overabbreviate names.
- Do not begin the name of the attribute with either `Method_` or `Device_`. The module framework reserves names that begin with these strings.

- `min_val` and `max_val` (`ulong`)

Define the minimum and maximum allowed values for the attributes. The module framework interprets the contents of these two fields differently, depending on the data type of the attribute. If the attribute is one of the integer data types, these fields contain the minimum and maximum integer values the attribute can have. For attributes with the `CFG_ATTR_STRTYPE` data type, these fields contain the minimum and maximum lengths of the string. For attributes with the `CFG_ATTR_BINTYPE` data type, these fields contain the minimum and maximum numbers of bytes allowed.

- `val_size` (ulong)

If the attribute is a binary type, this field contains the current size (in bytes) of the attribute value. This field is not used if the attribute is an integer or string.

- `type` (uchar)

Specifies the data type of the value for this attribute. See Section 3.2.1 for a list of values for this field.

- `operation` (uchar)

Specifies the operations that the module allows on this attribute (for example, initialize or query). This field is a bit mask. See Section 3.2.2 for a list of values for this field.

3.2.1 Attribute Data Types

The following data types are supported for attribute table entries:

`CFG_ATTR_STRTYPE` – A null-terminated array of characters
`CFG_ATTR_INTTYPE` – A 32-bit signed integer
`CFG_ATTR_UINTTYPE` – A 32-bit unsigned integer
`CFG_ATTR_LONGTYPE` – A 64-bit signed integer
`CFG_ATTR_ULONGTYPE` – A 64-bit unsigned integer
`CFG_ATTR_BINTYPE` – An array of bytes

3.2.2 Operations Allowed on an Attribute

You can set the `operation` field in an attribute table entry to any combination of the following request codes:

`CFG_OP_CONFIGURE`

The value of the attribute can be modified during initialization using a data value from the `/etc/sysconfigtab` file. (Section 10.6 describes how to create the `/etc/sysconfigtab` file.) If the kernel address for the attribute is specified in the attribute table, the initialization occurs before the module framework calls the kernel module's `configure` routine with the `CFG_OP_CONFIGURE` request code. If the attribute's address is not specified, the `configure` routine must perform the modification itself.

Setting this flag in the operator field allows the system administrator to set the value of the attribute through the `/etc/sysconfigtab` file. This gives the system administrator the ability to tune your module each time it is loaded.

CFG_OP_QUERY

Setting this flag allows users or applications to retrieve the value of the attribute. The module framework can read the attribute and return it to applications. The attribute's value is retrieved before the module framework calls the kernel module's `configure` routine with the `CFG_OP_QUERY` request code. (See Section 3.3.)

CFG_OP_RECONFIGURE

Setting this flag allows the value of the attribute to be modified by users or applications at any time after the kernel module is up and running. The module framework sets the value before it calls the `configure` routine with the `CFG_OP_RECONFIGURE` request code. (See Section 3.4.)

CFG_HIDDEN_ATTR

Setting this flag prevents the attribute from displaying in the output of a `cfg_subsys_query_all` operation.

Note

If you do not specify the kernel address of an attribute in the attribute table, the `configure` routine must handle the setting, resetting, and retrieval of the attribute value by itself. The module framework cannot perform these actions automatically, unless you supply the kernel address of the attribute.

3.3 Attribute Get Requests

When an application wants to get attribute values of a kernel module, it calls the `cfg_subsys_query(3)` routine or the `cfg_subsys_query_all(3)` routine in the `/usr/ccs/lib/libcfg.a` library. The library makes the request to the module framework.

The module framework validates the requests to get the valid attribute values. After successful validation, the module framework calls the `configure` routine with the `CFG_OP_QUERY` request code. Figure 3-1 illustrates these relationships.

Figure 3–1: Attribute Get Requests

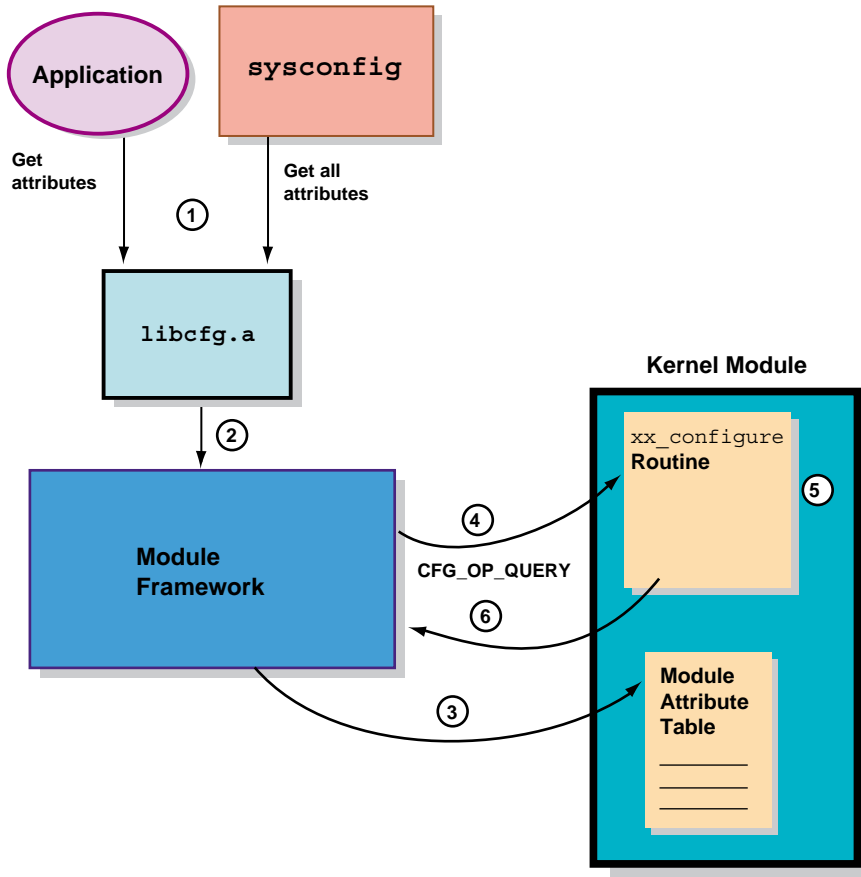

ZK-1543U-AI

The following list presents the sequence of steps in an attribute get request:

- ❶ The application requests specific attributes or all attributes by calling the appropriate library routine in `/usr/ccs/lib/libcfg.a`.
- ❷ The library passes the request to the module framework.
- ❸ The module framework reads the requested attributes if the attribute's address is specified in the attribute table.
- ❹ The module framework calls the `configure` routine with `CFG_OP_QUERY`.
- ❺ The `configure` routine handles returning values for the requested attributes whose address is not specified in the attribute table.
- ❻ The `configure` routine returns control to the module framework.

Consider the following when you use attribute get requests:

- You do not have to process a `CFG_OP_QUERY` request in your `configure` routine; you can simply return `ESUCCESS`.
- If you do not keep some or all of your attributes up to date or if you want to have control over a get operation, do the following:
 - Do not give the attribute's kernel address in the attribute table and make the address `NULL`.
 - Bring all your attributes up to date when you receive the `CFG_OP_QUERY` request.
 - Process the `CFG_OP_QUERY` request by providing the attribute's values to the `indata` parameter (see Section 2.1) and by setting the attribute's status appropriately.
 - To determine which attributes are being requested, use the `indata` parameter.

3.4 Attribute Set Requests

When an application wants to set attribute values of a kernel module, it calls the `cfg_subsys_reconfig(3)` routine in the `/usr/ccs/lib/libcfg.a` library. The library makes the request to the module framework.

The module framework sets the values of the requested attributes, then calls the `configure` routine with the `CFG_OP_RECONFIGURE` request code. The kernel module evaluates these values and functions accordingly. Figure 3-2 illustrates these relationships.

Figure 3–2: Attribute Set Requests

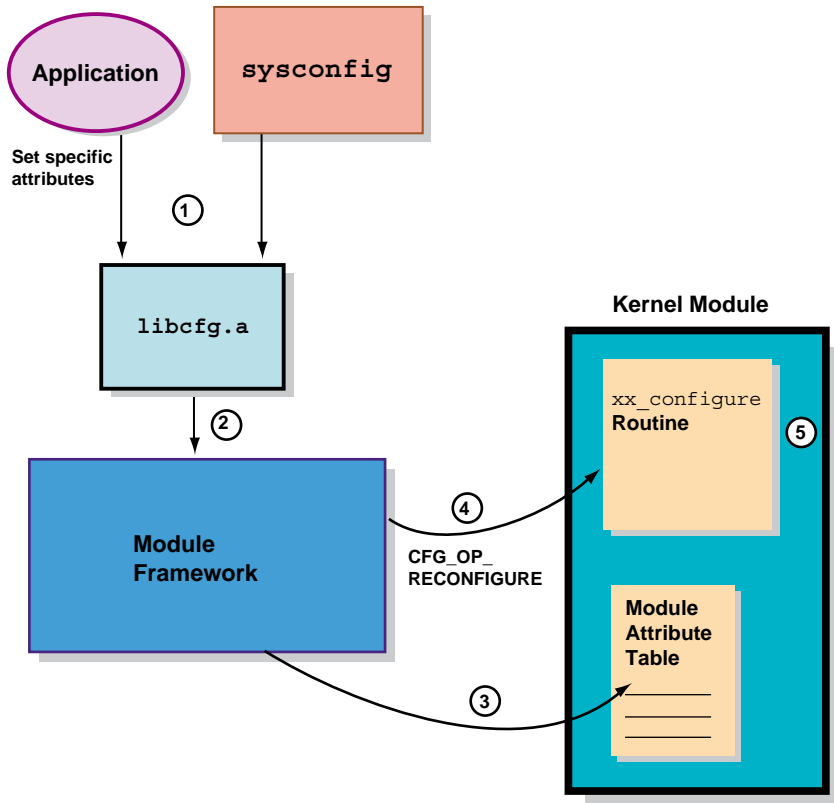

ZK-1544U-AI

The following list presents the sequence of steps in an attribute set request:

- 1 The application requests to set the values of specific attributes.
- 2 The library passes the request to the module framework.
- 3 The module framework checks if the new value falls within the range specified in the attribute table and sets the status of each attribute. If the value checking succeeds, the module framework sets the attribute's value to the new value.
- 4 The module framework calls the `configure` routine with `CFG_OP_RECONFIGURE`.
- 5 The kernel module evaluates the new values and executes based on those values.

Dispatch Point Callbacks

This chapter describes callbacks in relation to dispatch points along the boot timeline and the rules for implementing them in your kernel module. Kernel modules may contain one or more callback routines, which perform different tasks at different dispatch points. The kernel interacts with the callback routines to perform these tasks at the appropriate time.

This chapter contains the following information:

- The UNIX boot timeline and how callbacks are affected
- Why you would use callbacks in your kernel module
- Dispatch points along the UNIX boot timeline
- How to implement callbacks in your kernel module

4.1 Understanding the UNIX Boot Timeline

To understand why callbacks are needed and how to implement them, you need to understand some details of the UNIX boot timeline.

The boot timeline represents all code that executes while the system boots. Key to the boot process are dispatch points that indicate certain functions can be done. In kernel mode, dispatch points occur in a specifically ordered manner (see Section 4.3). For example, the kernel-mode dispatch point `CFG_PT_VM_AVAIL` indicates the point where virtual memory can be allocated. Any activity your module performs that requires the allocation of virtual memory must happen at or after this dispatch point. In user mode, the dispatch points are more loosely ordered.

Callbacks are the mechanism for ensuring that the code in your module executes at the right point along the boot timeline. Section 4.4 describes ways that you can code your callback routine and, consequently, register the callback in your kernel module.

Figure 4-1 shows the boot timeline and kernel-mode dispatch points.

Figure 4–1: Dispatch Points Along the Boot Timeline

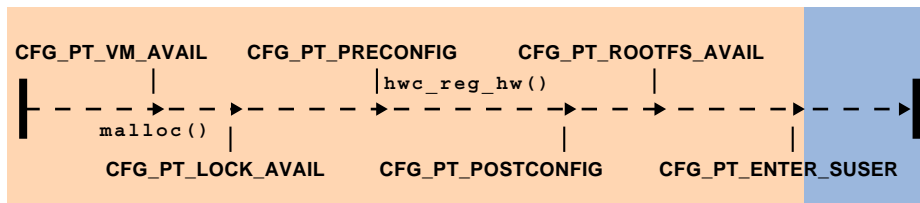

ZK-1542U-AI

The arrows along the timeline depict the dispatch points. Note that the routines shown in the example can be called at any time once the dispatch point is reached, but not before.

4.2 Why Use Callbacks?

Many kernel modules are dynamic modules—that is, they are dynamically loaded into memory as needed. Other kernel modules are statically loaded as part of `/vmunix` early in the boot timeline. For a kernel module to be a single binary image, it must be able to load statically as part of `/vmunix` or load dynamically as needed.

As explained in Chapter 2, when a module is loaded into memory, the only routine in the module that is known to the operating system is the `configure` routine. The module framework has access to the `configure` routine because of the predetermined name of the routine—that is, the module framework knows to look for a routine name ending with `_configure`. The framework calls the `configure` routine at initialization so that the kernel module can register its other routines with the rest of the operating system.

When static kernel modules are called to initialize themselves, they cannot allocate memory, initialize locks, or call any routine that is not yet available on the boot timeline. For example, as Figure 4–1 shows, the call to initialize a kernel module (`CFG_PT_VM_AVAIL`) occurs early in the boot timeline, while the dispatch point for locking (`CFG_PT_LOCK_AVAIL`) occurs later. To avoid the problem of calling routines that are not yet available, the kernel module can register a callback routine that will be called later in the boot timeline. When that routine is called, it will perform the required initialization correctly because the routines it requires will be available.

Callbacks, then, are the mechanism for implementing kernel modules as single binary images. Statically loaded kernel modules register callbacks that the module framework can execute at a later time. For a static configuration, callbacks are registered to execute at dispatch points along the boot timeline.

For example, the device switch subsystem is statically configured. It registers a callback routine to initialize the in-memory copy of the database after virtual memory is available (at the dispatch point called `CFG_PT_VM_AVAIL`). It registers another callback routine to update the on-disk database files, if necessary. This callback occurs after the root file system becomes writable (at dispatch point `CFG_PT_ROOTFS_WR`) because the subsystem's files reside on the root file system.

For a dynamically loaded module, callback routines that register with the dispatch points along the boot timeline are called directly from the `register_callback` routine because the dispatch point has already occurred.

Kernel modules call the `register_callback` routine to register their own callback routine. The kernel calls this routine when the specified dispatch point occurs.

4.3 Dispatch Points on the Boot Timeline

This section presents a list of dispatch points as they occur on the boot timeline. In kernel mode (prior to single-user mode), the dispatch points occur in a strict chronological order.

`CFG_PT_HAL_INIT`

Description: Hardware architecture layer is initialized.

`CFG_PT_VM_AVAIL`

Description: Virtual memory is available.

Common routines available: Device switch routines.

`CFG_PT_LOCK_AVAIL`

Description: Locking is available.

Common routines available: Routines that handle hardware registration.

`CFG_PT_TOPOLOGY_CONF`

Description: The topology configuration point. The operating system can create threads, timeouts begin working, kernel event management is available, the system begins incrementing time.

`CFG_PT_POSTCONFIG`

Description: Postscan the hardware. Tasks that require completion of hardware configuration can be performed at this dispatch point.

Hardware events are posted.

CFG_PT_GLROOTFS_AVAIL

Description: Global root file system has been mounted.

CFG_PT_ROOTFS_AVAIL

Description: Root file system has been mounted read-only. Tasks that require completion of the root file system mount operation can be performed at this dispatch point. Dynamic device registration can occur.

CFG_PT_ENTER_SUSER

Description: Enter single-user mode.

4.4 Implementing Callbacks in Your Kernel Module

This section describes how you code callbacks in your kernel module.

4.4.1 Coding Callbacks

To implement callbacks in your kernel module, you must:

- Call the `register_callback` routine
- Write a callback routine in your kernel module that will be passed parameters from the kernel's callback subsystem

Section 4.4.1.1 describes the first step in this process, registering your callback routine. It defines the parameters that are passed to the callback subsystem when you register callbacks. Section 4.4.1.2 describes how to write a callback routine in your kernel module that receives information from the callback subsystem prior to performing some task. Figure 4-2 shows how the kernel module uses the kernel's callback subsystem.

Figure 4–2: Using the Kernel Callback Subsystem

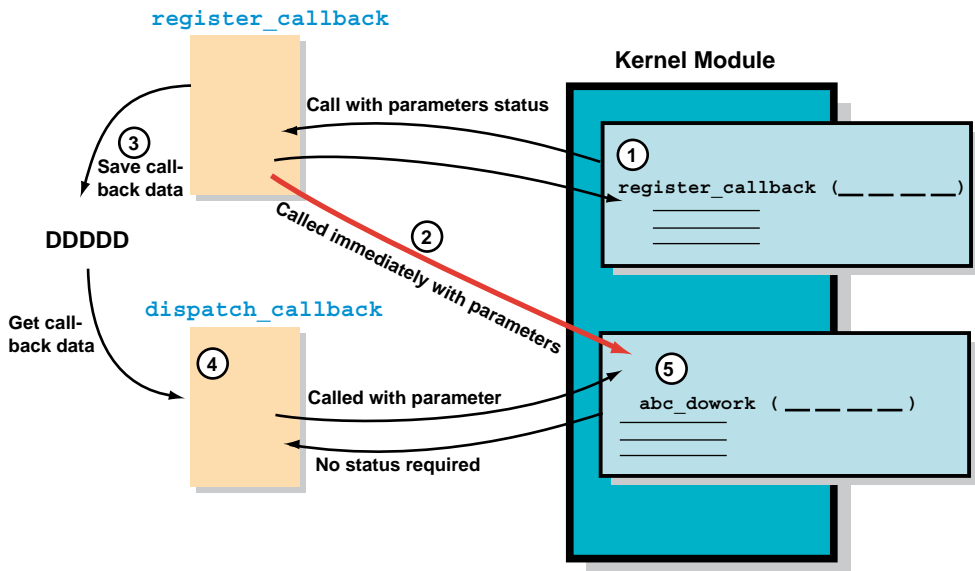

ZK-1537U-AI

- 1 Some routine, typically the configure routine, calls `register_callback` because it needs the kernel module callback routine (`abc_dowork` in the example) called at some later point. When you call `register_callback` to register your callback routine, you pass several parameters: the dispatch point, the priority, the address of the callback routine, and an argument to be passed to the callback routine.

When `register_callback` is called, it does either step 2 or step 3:

- 2 The `register_callback` routine calls `abc_dowork` directly if the kernel dispatch point is on the boot timeline and it has already occurred. This completes the callback sequence.
- 3 The `register_callback` routine saves information about the callback and proceeds to the next step in the callback sequence. (This is the normal operation.)
- 4 The routine `dispatch_callback` calls the kernel module callback routine `abc_dowork` at the appropriate dispatch point.
- 5 The kernel module callback routine executes.

4.4.1.1 Calling the `register_callback` Routine

The `register_callback` routine enables your kernel module to execute its callback routine by storing callback information until the correct dispatch point. The `register_callback` routine has the following format:

```
int register_callback(void (*func)(), int point, int order, ulong arg);
```

where

- The `func` parameter is the name of the callback routine that you want called at a particular dispatch point.
- The `point` parameter is the value of the dispatch point at which you want your callback routine called (for example, `CFG_PT_VM_AVAIL`).
- The `order` parameter is used to order multiple callback requests registered for the same dispatch point. A request with a smaller order value is executed before a request with a larger value. A kernel module may use this to coordinate among other modules. The order constant most useful to kernel module writers is `CFG_ORD_DONTCARE`. This constant registers the callback with no specific order priority.

If you are a device driver writer, consider using one of the following order constants:

`CFG_ORD_NOMINAL`—Registers the callback with lowest order priority.

`CFG_ORD_MAXIMUM`—Registers the callback with the highest order priority.

- The `arg` parameter is used by the kernel module to communicate information to the callback routine. Pass the integer `0L` to indicate that you do not want to pass an argument.

When you call `register_callback` to register your callback routine, the information you pass says, in effect, “At this dispatch point, with this priority, call the kernel module callback routine with this argument.” Normally, the callback will occur later than the `register_callback` call. There is one exception: if the callback being registered is for a dispatch point along the boot timeline that has already passed, the callback occurs immediately.

Upon successful completion, the `register_callback` routine returns the status value `ESUCCESS`. Otherwise, it returns one of the following error status values:

`ENOMEM`—The system limit on the maximum number of registered callbacks was exceeded. You can correct this error by increasing the value of the `max_callbacks` attribute in the `cm` subsystem and then rebooting the system. (See *System Configuration and Tuning* for details.)

`EINVAL`—The value that you passed as the `point` argument is outside the minimum and maximum range.

A kernel module calls the `unregister_callback` routine to deregister a callback. It has the following format:

```
int unregister_callback(void (*func)(), int point, int order, ulong arg);
```

where the parameters are identical to those used by `register_callback`. Note that some callbacks may never be unregistered.

4.4.1.2 Writing the Callback Routine

When a callback occurs, the kernel executes the callback routine you specified in the call to `register_callback`. The callback routine does all the callback processing and implements whatever action you require when the callback occurs. The callback routine is most often written as part of your kernel module. It can be statically linked to the kernel as part of `/vmunix` or dynamically loaded at run time. The requirement is that it exists in the kernel prior to when the callback occurs.

The callback routine that you write in your kernel module is passed the dispatch point, order, and argument parameters when it is called.

A kernel module callback routine must conform to the following format:

```
void xx_callback(int point, int order, ulong arg, ulong arg2);
```

where the parameters are defined as follows:

- The `point` parameter is the value associated with the dispatch point. The value from the same parameter in the corresponding call to `register_callback` is passed.
- The `order` parameter specifies the order in which the callback routine is being called. The value from the same parameter in the corresponding call to `register_callback` is passed.
- The `arg` parameter specifies the argument that the kernel module asked to pass to the callback routine. The value from the same parameter in the corresponding call to `register_callback` is passed.
- The `arg2` parameter is an additional value supplied by the callback dispatcher. It is used to communicate point-specific information to the callback routine. For many dispatch points, this parameter is not used.

4.4.2 Registering Callbacks

To code callbacks in your kernel module, register all the callbacks in your `configure` routine. The following pseudocode fragment for `abc_configure.mod` registers two callbacks from within the `configure` routine:

```

:
:
abc_configure (opcode, ...){
    switch (opcode) {
        case CFG_OP_CONFIGURE:
            register_callback (abc_vm, CFG_PT_VM_AVAIL, CFG_ORD_DONTCARE, arg1)
            .
            register_callback (abc_post, CFG_PT_POST_CONFIG, CFG_ORD_DONTCARE, arg2)
            :
            :
        }
    }
}
abc_vm (int point, int priority, int arg){
:
:
}
abc_post (int point, int priority, int arg){
:
:
}

```

Note

Because there are a limited number of callbacks that you can use, registering a large number of callback entries is not recommended.

4.4.3 Nesting Callbacks and Deregistering Callbacks

A kernel module can register multiple callbacks, possibly at different callback points, by calling `register_callback()` many times. Callbacks may not, however, be nested—calling `register_callback()` from within a callback routine is illegal.

To enable deregistration, call `unregister_callback()` from within a callback routine. This allows a callback to unregister itself or other callbacks.

4.4.4 Defining New Dispatch Points in your Kernel Module

You can write a kernel module that uses the predefined dispatch points (see Section 4.3), or you can write a module that defines and uses new ones. The following steps describe how to define a new kernel dispatch point:

1. Choose and reserve a unique number for the new dispatch point.

The valid range for developer-defined dispatch points is listed in the `/usr/include/sys/sysconfig.h` file, along with the values for the system-defined dispatch points.

Values for developer-defined run-time dispatch points triggered within the kernel must be within the range of these values:

CFG_PT_RUNTIME_KERN_MIN_EXT (20000) to
CFG_PT_RUNTIME_KERN_MAX_EXT (29999).

Values for developer-defined run-time dispatch points triggered outside the kernel (user mode) must be within the following range:

CFG_PT_RUNTIME_USER_MIN_EXT (30000) to
CFG_PT_RUNTIME_USER_MAX_EXT (39999).

2. Trigger the callback.

All kernel callbacks triggered within the kernel are activated by the `dispatch_callback()` routine, which has the following format:

```
dispatch_callback (CFG_PT_MYPPOINT, arg2)
```

where `CFG_PT_MYPPOINT` is the unique value for the dispatch point you define and `arg2` communicates point-specific information to the callback routine. Thus, when you define a dispatch point triggered from the kernel, you need to insert the `dispatch_callback()` call at the appropriate place within your kernel module.

In contrast, when you define a dispatch point triggered from user space, you do not need to supply the `dispatch_callback()` call in the kernel module. A callback triggered from user mode is accomplished by setting the value of the `user_cfg_pt` attribute in the generic subsystem to the value of the dispatch point. For example, if you define a dispatch point triggered in user mode with a value of 35600, the following command triggers callbacks registered for this dispatch point:

```
sysconfig -r generic user_cfg_pt=35600
```

To trigger the callback, you would execute the above command from within a script or from the user prompt. Alternately, you could call the `cfg_subsys_reconfig(3)` routine from within a program to achieve the same result.

5

Kernel-Mode Capabilities

Tru64 UNIX offers several kernel-mode programming capabilities. This chapter describes the tasks that you can do in kernel mode:

- Work with string routines
- Use data copying routines
- Use kernel-related routines
- Manage system time
- Use kernel threads
- Use locks

This chapter discusses the routines most commonly used and provides code fragments to illustrate how to call them in a kernel module. These code fragments and associated descriptions supplement the reference page descriptions for these and the other routines presented in *Reference Pages, Section 9r; Device Drivers (Volume 1)*.

5.1 Using String Routines

String routines allow kernel modules to:

- Compare two null-terminated strings
- Compare two strings by using a specified number of characters
- Copy a null-terminated character string
- Copy a null-terminated character string with a specified limit
- Return the number of characters in a null-terminated string

The following sections describe the routines that perform these tasks.

5.1.1 Comparing Two Null-Terminated Strings

To compare two null-terminated character strings, call the `strcmp` routine. The following code fragment shows a call to `strcmp`:

```
:\nregister struct device *device;\nstruct controller *ctrlr;
```

```

:
:
if (strcmp(device->ctrl_name, ctrl->ctrl_name)) { ❶
:
:
}

```

❶ Shows that the `strcmp` routine takes two arguments:

- The first argument specifies a pointer to a string (an array of characters terminated by a null character). In this example, this is the controller name pointed to by the `ctrl_name` field of the pointer to the `device` structure.
- The second argument also specifies a pointer to a string. In the example, this is the controller name pointed to by the `ctrl_name` field of the pointer to the `controller` structure.

The code fragment sets up a condition statement that performs tasks based on the results of the comparison. Figure 5–1 shows how `strcmp` compares two sample character-string values in the code fragment. In item 1, `strcmp` compares the two controller names and returns the value 0 (zero) because the two strings were identical.

In item 2, `strcmp` returns an integer that is less than zero because the lexicographical comparison indicates that the characters in the first controller name, `fb`, come before the letters in the second controller name, `ipi`. In other words, the first pair of letters—in the same position in both strings—that do not match are `f` and `i`, and `f` is less than `i`.

Figure 5–1: Results of the `strcmp` Routine

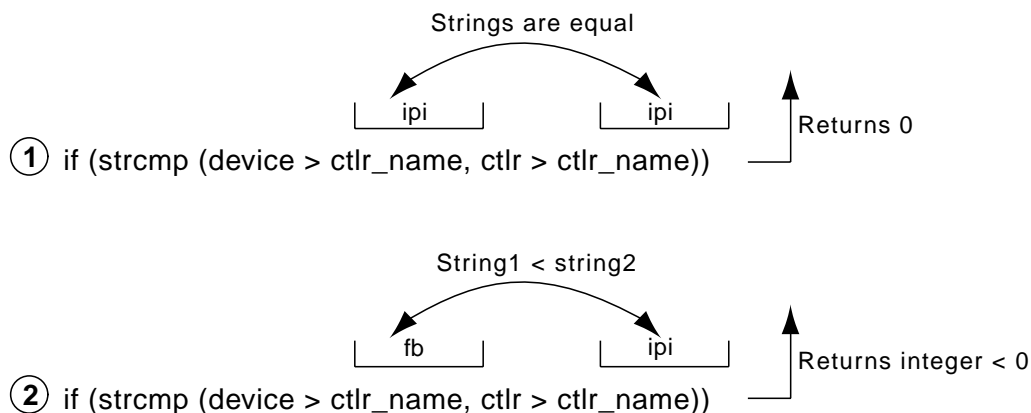

ZK-0624U-AI

5.1.2 Comparing Two Strings by Using a Specified Number of Characters

To compare two strings by using a specified number of characters, call the `strncmp` routine. The following code fragment shows a call to `strncmp`:

```
:\n:\nregister struct device *device;\n:\n:\nif( (strncmp(device->dev_name, "rz", 2) == 0)) ❶\n:\n:\n
```

❶ Shows that the `strncmp` routine takes three arguments:

- The first argument specifies a pointer to a string. In the example, this is the device name pointed to by the `dev_name` field of the pointer to the `device` structure.
- The second argument also specifies a pointer to a string. In the example, this is the character string `rz`.
- The third argument specifies the number of bytes to be compared. In the example, the number of bytes to compare is 2.

The code fragment sets up a condition statement that performs tasks based on the results of the comparison. Figure 5-2 shows how `strncmp` compares two sample character-string values in the code fragment. In item 1, `strncmp` compares the first two characters of the device name `none` with the string `rz` and returns an integer less than the value 0 (zero). The reason for this is that `strncmp` makes a lexicographical comparison between the two strings and the string `no` comes before the string `rz`. In item 2, `strncmp` compares the first two characters of the device name `rza` with the string `rz` and returns the value 0 (zero). The reason for this is that `strncmp` makes a lexicographical comparison between the two strings and the string `rz` is equal to the string `rz`.

Figure 5–2: Results of the strncmp Routine

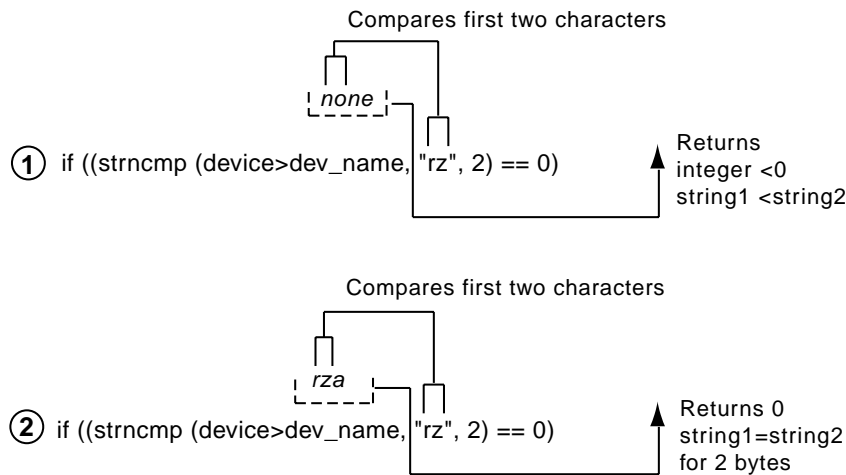

ZK-0568U-AI

5.1.3 Copying a Null-Terminated Character String

To copy a null-terminated character string, call the `strcpy` routine. The following code fragment shows a call to `strcpy`:

```

:
:
struct tc_slot tc_slot[TC_IOSLOTS]; 1
char curr_module_name[TC_ROMNAMLEN + 1]; 2
:
:
strcpy(tc_slot[i].module_name, curr_module_name); 3
:
:

```

- 1 Declares an array of `tc_slot` structures of size `TC_IOSLOTS`.
- 2 Declares a variable to store the module name from the ROM of a device on the TURBOchannel bus.
- 3 Shows that the `strcpy` routine takes two arguments:
 - The first argument specifies a pointer to a buffer large enough to hold the string to be copied. In the example, this buffer is the `module_name` field of the `tc_slot` structure associated with the specified bus.
 - The second argument specifies a pointer to a string. This is the string to be copied to the buffer specified by the first argument. In the example, this is the module name from the ROM, which is stored in the `curr_module_name` variable.

Figure 5–3 shows how `strcpy` copies a sample value in the code fragment. The routine copies the string `CB` (the value contained in `curr_module_name`) to the `modulename` field of the `tc_slot` structure associated with the specified bus. This field is presumed large enough to store the character string. The `strcpy` routine returns the pointer to the location following the end of the destination buffer.

Figure 5–3: Results of the `strcpy` Routine

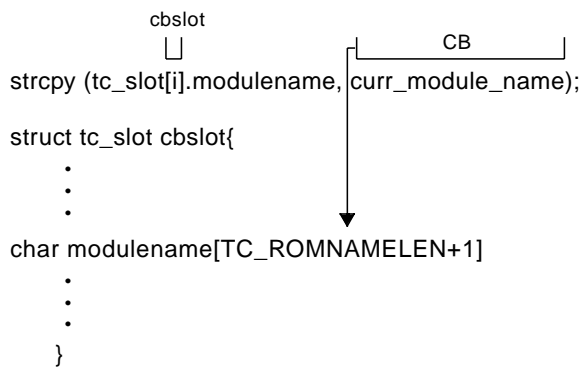

ZK-0625U-AI

5.1.4 Copying a Null-Terminated Character String with a Specified Limit

To copy a null-terminated character string with a specified limit, call the `strncpy` routine. The following code fragment shows a call to `strncpy`:

```

:
:
register struct device *device;
char * buffer;
:
:
strncpy(buffer, device->dev_name, 2); ❶
if (buffer == somevalue)
:
:

```

❶ Shows that `strncpy` takes three arguments:

- The first argument specifies a pointer to a buffer of at least the same number of bytes as specified in the third argument. In the example, this is the pointer to the `buffer` variable.
- The second argument specifies a pointer to a string. This is the character string to be copied and in the example is the value

pointed to by the `dev_name` field of the pointer to the device structure.

- The third argument specifies the number of characters to copy, which in the example is two characters.

The code fragment sets up a condition statement that performs some tasks based on the characters stored in the pointer to the `buffer` variable.

Figure 5-4 shows how `strncpy` copies a sample value in the code fragment. The routine copies the first two characters of the string `none` (the value pointed to by the `dev_name` field of the pointer to the device structure). The `strncpy` routine stops copying after it copies a null character or the number of characters specified in the third argument, whichever comes first.

The figure also shows that `strncpy` returns a pointer to the `/NULL` character at the end of the first string (or to the location following the last copied character if there is no `NULL`). The copied string will not be null terminated if its length is greater than or equal to the number of characters specified in the third argument.

Figure 5-4: Results of the `strncpy` Routine

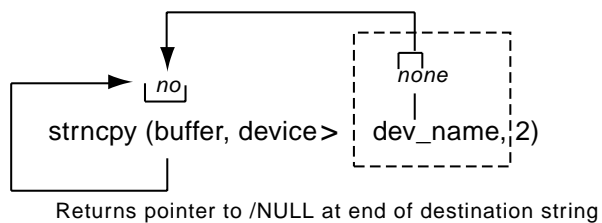

ZK-0793U-AI

5.1.5 Returning the Number of Characters in a Null-Terminated String

To return the number of characters in a null-terminated character string, call the `strlen` routine. The following code fragment shows a call to `strlen`:

```
...
char *strptr;
...
if ((strlen(strptr)) > 1) ❶
```

❶ Shows that the `strlen` routine takes one argument: a pointer to a string. In the example, this pointer is the variable `strptr`.

The code fragment sets up a condition statement that performs some tasks based on the length of the string. Figure 5-5 shows how `strlen` checks the number of characters in a sample string in the code fragment. As the figure shows, `strlen` returns the number of characters pointed to by the `strptr` variable, which in the code fragment is four. Note that `strlen` does not count the terminating null character.

Figure 5-5: Results of the `strlen` Routine

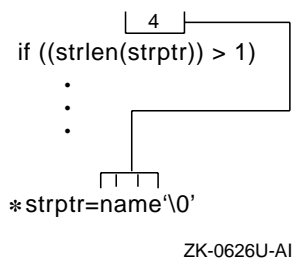

5.2 Using Data Copying Routines

The data copying routines allow kernel modules to:

- Copy a series of bytes with a specified limit
- Zero a block of memory
- Copy data from user address space to kernel address space
- Copy data from kernel address space to user address space
- Move data between user virtual space and system virtual space

The following sections describe the routines that perform these tasks.

5.2.1 Copying a Series of Bytes with a Specified Limit

To copy a series of bytes with a specified limit, call the `bcopy` routine. The following code fragment shows a call to `bcopy`:

```

:
: struct tc_slot  tc_slot[TC_IOSLOTS]; 1
:
: char *cp; 2
:
: bcopy(tc_slot[index].modulename, cp, TC_ROMNAMLEN + 1); 3
:
:

```

5.2.2 Zeroing a Block of Memory

To zero a block of memory, call the `bzero` routine. The following code fragment shows a call to `bzero`.

```
:\n:\nstruct bus *new_bus;\n:\n:\nbzero(new_bus, sizeof(struct bus)); [1]\n:\n:\n
```

[1] Shows that the `bzero` routine takes two arguments:

- The first argument is a pointer to a string whose size is at least the size specified in the second argument. In the example, the first argument is a pointer to a `bus` structure.
- The second argument is the number of bytes to be zeroed. In the example, this size is expressed through the use of the `sizeof` operator, which returns the size of a `bus` structure.

In the example, `bzero` zeros the number of bytes associated with the size of the `bus` structure, starting at the address specified by `new_bus`.

5.2.3 Copying Data from User Address Space to Kernel Address Space

To copy data from the unprotected user address space to the protected kernel address space, call the `copyin` routine. The following code fragment shows a call to `copyin`:

```
:\n:\nregister struct buf *bp;\nint err;\ncaddr_t buff_addr;\ncaddr_t kern_addr;\n:\n:\nif (err = copyin(buff_addr,kern_addr,bp->b_resid)) { [1]\n:\n:\n
```

[1] Shows that the `copyin` routine takes three arguments:

- The first argument specifies the address in user space of the data to be copied. In the example, this address is the user buffer's address.
- The second argument specifies the address in kernel space to copy the data to. In the example, this address is the address of the kernel buffer.

- The third argument specifies the number of bytes to copy. In the example, the number of bytes is contained in the `b_resid` field of the pointer to the `buf` structure.

The code fragment sets up a condition statement that performs tasks based on whether `copyin` executes successfully. Figure 5-7 shows how `copyin` copies data from user address space to kernel address space by using sample data.

As Figure 5-7 shows, `copyin` copies the data from the unprotected user address space (specified by `buff_addr`) to the protected kernel address space (specified by `kern_addr`). The `b_resid` field indicates the number of bytes. The figure also shows that `copyin` returns the value 0 (zero) upon successful completion. If the address in user address space cannot be accessed, `copyin` returns the error `EFAULT`.

Figure 5-7: Results of the `copyin` Routine

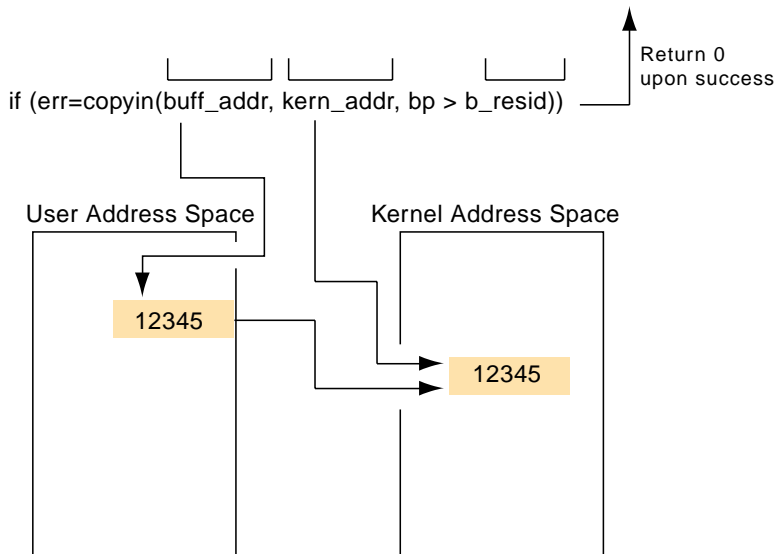

ZK-0628U-AI

5.2.4 Copying Data from Kernel Address Space to User Address Space

To copy data from the protected kernel address space to the unprotected user address space, call the `copyout` routine. The following code fragment shows a call to `copyout`:

```
:\n:\nregister struct buf *bp;\nint err;\ncaddr_t buff_addr;\ncaddr_t kern_addr;\n:\n:\nif (err = copyout(kern_addr,buff_addr,bp->b_resid)) { 1\n:\n:\n
```

1 Shows that the `copyout` routine takes three arguments:

- The first argument specifies the address in kernel space of the data to be copied. In the example, this address is the kernel buffer's address, which is stored in the `kern_addr` argument.
- The second argument specifies the address in user space to copy the data to. In the example, this address is the user buffer's virtual address, which is stored in the `buff_addr` argument.
- The third argument specifies the number of bytes to copy. In the example, the number of bytes is contained in the `b_resid` field of the pointer to the `buf` structure.

Figure 5-8 shows the results of `copyout`, based on the code fragment. As the figure shows, `copyout` copies the data from the protected kernel address space (specified by `kern_addr`) to the unprotected user address space (specified by `buff_addr`). The number of bytes is indicated by the `b_resid` field. The figure also shows that `copyout` returns the value 0 (zero) upon successful completion. If the address in kernel address space cannot be accessed or if the number of bytes to copy is invalid, `copyout` returns the error `EFAULT`.

Figure 5–8: Results of the copyout Routine

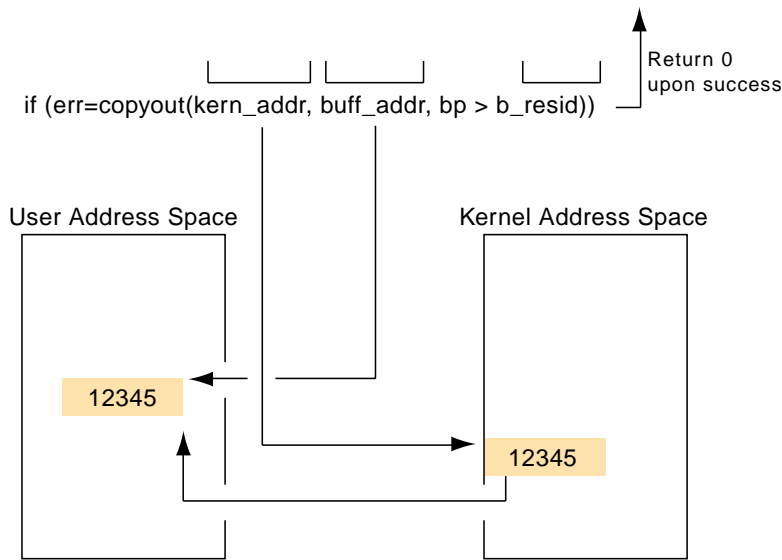

ZK-0629U-AI

5.2.5 Moving Data Between User Virtual Space and System Virtual Space

To move data between user virtual space and system virtual space, call the `uiomove` routine. The following code fragment shows a call to `uiomove`:

```
:
struct uio *uio;
register struct buf *bp;
int err;
int cnt;
unsigned tmp;
:
err = uiomove(&buf,cnt,uio); ❶
:
```

❶ Shows that the `uiomove` routine takes three arguments:

- The first argument specifies a pointer to the kernel buffer in system virtual space.
- The second argument specifies the number of bytes of data to be moved. In this example, the number of bytes to be moved is stored in the `cnt` variable.

- The third argument specifies a pointer to a `uio` structure. This structure describes the current position within a logical user buffer in user virtual space.

5.3 Using Kernel-Related Routines

The kernel-related routines allow kernel modules to:

- Print text to the console and error logger
- Put a calling process to sleep
- Wake up a sleeping process
- Initialize a timer (callout) queue element
- Remove the scheduled routine from the timer queues
- Set the interrupt priority mask
- Allocate memory

The following sections describe the routines that perform these tasks.

5.3.1 Printing Text to the Console and Error Logger

To print text to the console terminal and the error logger, call the `printf` routine. The kernel `printf` routine is a scaled-down version of the C library `printf` routine. The `printf` routine prints diagnostic information directly on the console terminal and writes ASCII text to the error logger. Because `printf` is not interrupt driven, all system activities are suspended when you call it. Only a limited number of characters (currently 128) can be sent to the console display during each call to any section of a module. The reason is that the characters are buffered until the module returns to the kernel, at which time they are actually sent to the console display. If more than 128 characters are sent to the console display, the storage pointer may wrap around, discarding all previous characters; or it may discard all characters following the first 128.

If you need to see the results on the console terminal, limit the message size to the maximum of 128 whenever you send a message from within the module. However, `printf` also stores the messages in an error log file. You can use the `uerf` command to view the text of this error log file. See the `printf(9)` reference page for this command. The messages are easier to read if you use `uerf` with the `-o terse` option.

The following code fragment shows a call to this routine:

```
:\nprintf("CBprobe @ %8x, vbaddr = %8x, ctrl = %8x\\n",cbprobe,vbaddr,ctrl);\n:\n
```

The code example shows a typical use for the `printf` routine in the debugging of kernel modules. In the example, `printf` takes two arguments:

- The first argument specifies a pointer to a string that contains two types of objects. One object is ordinary characters such as, “hello, world,” which are copied to the output stream. The other object is a conversion specification, such as `%d`. (Supported conversion specifications include `%c`, `%d`, `%ld`, `%lx`, `%o`, `%s`, and `%x`. See `printf(9)` for explanations of these specifications.)
- The second argument specifies the argument list. In this example, the argument list consists of the arguments `cbprobe`, `vbaddr`, and `ctrl`.

The operating system also supports the `uprntf` routine. The `uprntf` routine prints to the current user’s terminal. Interrupt service routines should never call `uprntf`. It does not perform any space checking, so do not use this routine to print verbose messages. The `uprntf` routine does not log messages to the error logger.

5.3.2 Putting a Calling Process to Sleep

To put a calling process to sleep in a symmetric multiprocessing (SMP) environment, call the `mpsleep` routine. The `mpsleep` routine blocks the current kernel thread until a wakeup is issued (see Section 5.3.3).

Generally, kernel modules call this routine to wait for the transfer to complete an interrupt from the device. That is, the `write` routine of the kernel module sleeps on the address of a known location, and the device’s interrupt service routine wakes the process when the device interrupts. It is the responsibility of the wakened process to check if the condition for which it was sleeping has been removed. The following code fragment shows a call to this routine:

```
:\nmpsleep((vm_offset_t)&sc->error_recovery_flag, PCATCH,\n        "ftaerr", 0, &sc->lk_fta_kern_str,\n        MS_LOCK_SIMPLE | MS_LOCK_ON_ERROR))1\n:\n
```

¹ Calls the `mpsleep` routine to block the current kernel thread. The `mpsleep` routine takes several arguments:

- The `channel` argument specifies an address associated with the calling kernel thread to be put to sleep. In this example, the address (or event) associated with the current kernel thread is stored in the `error_recovery_flag` field.
- The `pri` argument specifies whether the sleep request is interruptible. Setting this argument to the `PCATCH` flag causes the process to sleep in an interruptible state (that is, the kernel thread can take asynchronous signals). Not setting the `PCATCH` flag causes the process to sleep in an uninterruptible state (that is, the kernel thread cannot take asynchronous signals).
- The `wmesg` argument specifies the wait message. In this call, `fta_error_recovery` passes the string `ftaerr`.
- The `timo` argument specifies the maximum amount of time the kernel thread should block. If you pass the value 0 (zero), `mpsleep` assumes there is no timeout.
- The `lockp` argument specifies a pointer to a simple or complex lock. You pass a simple or complex lock structure pointer if you want to release the lock. Pass the value 0 (zero) if you do not want to release the lock.
- The `flags` argument specifies the lock type. You can pass the bitwise inclusive OR of the valid lock bits defined in `/usr/sys/include/sys/param.h`.

5.3.3 Waking Up a Sleeping Process

To wake up all processes sleeping on a specified address, call the `wakeup` routine. The following code fragment shows a call to this routine:

```

:
wakeup(&ctrlr->bus_name); 1
:

```

- ¹ Shows that the `wakeup` routine takes one argument: the address on which the wakeup is to be issued. In the example, this address is that of the bus name associated with the bus to which this controller is connected. This address was specified in a previous call to the `mpsleep` routine. All processes sleeping on this address are wakened.

5.3.4 Initializing a Timer (Callout) Queue Element

To initialize a timer queue element, call the `timeout` routine. The following code fragment shows a call to this routine:

```

:
:
#define NONEIncSec 1
:
:
cb = &none_unit[unit];
:
:
timeout(noneinclcd, (caddr_t)none, NONEIncSec*hz); 1
:
:

```

1 Shows that the `timeout` routine takes three arguments:

- The first argument specifies a pointer to the routine to be called. In the example, `timeout` will call the `noneinclcd` routine on the interrupt stack (not in processor context) as dispatched from the `softclock` routine.
- The second argument specifies a single argument to be passed to the called routine. In the example, this argument is the pointer to the `NONE` device's `none_unit` data structure. This argument is passed to the `noneinclcd` routine. Because the data types of the arguments are different, the code fragment performs a type-casting operation that converts the argument type to be of type `caddr_t`.
- The third argument specifies the amount of time to delay before calling the specified routine. You express time as ticks. To obtain a particular time in seconds, you multiply the number of seconds times `hz` (`hz` contains the number of ticks per second).

In the example, the constant `NONEIncSec` is used with the `hz` global variable to determine the amount of time before `timeout` calls `noneinclcd`. The global variable `hz` contains the number of clock ticks per second. This variable is a second's worth of clock ticks. The example illustrates a 1-second delay.

5.3.5 Removing Scheduled Routines from the Timer (Callout) Queue

To remove the scheduled routines from the timer queue, call the `untimeout` routine. The following code fragment shows a call to this routine:

```

:
:
untimeout(noneinclcd, (caddr_t)none); 1
:
:

```

1 Shows that the `untimeout` routine takes two arguments:

- The first argument specifies a pointer to the routine to be removed from the timer queue. In the example, `untimeout` removes the `noneinclcd` routine from the timer queue. This routine was placed on the timer queue in a previous call to the `timeout` routine.

- The second argument specifies a single argument to be passed to the called routine. In the example, this argument is the pointer to the `NONE` device's `none_unit` data structure. It matches the parameter that was passed in a previous call to `timeout`. Because the data types of the arguments are different, the code fragment performs a type-casting operation that converts the argument type to be of type `caddr_t`.

The two arguments are used to uniquely identify which `timeout` entry to remove. This is useful if more than one thread has called `timeout` with the same routine argument.

5.3.6 Setting the Interrupt Priority Mask

To set the interrupt priority level (IPL) mask to a specified level, call one of the `spl` routines. Table 5-1 summarizes the uses for the different `spl` routines.

Table 5-1: Uses for `spl` Routines

<code>spl</code> Routine	Meaning
<code>splextreme</code>	Highest priority; blocks everything except halt interrupts (for example, realtime devices, machine checks, and so forth).
<code>splrt</code>	Blocks realtime devices (performs everything except machine checks and halt interrupts).
<code>splclock</code>	Masks all hardware clock interrupts.
<code>splhigh</code>	Masks all interrupts except realtime devices, machine checks, and halt interrupts.
<code>spldevhigh</code>	Masks all device and software interrupts.
<code>splbio</code>	Masks all disk and tape controller interrupts.
<code>splimp</code>	Masks all LAN hardware interrupts.
<code>splvm</code>	Masks all virtual memory clock interrupts.
<code>splnet</code>	Masks all network software interrupts.
<code>splsoftclock</code>	Masks all software clock interrupts.

Table 5–1: Uses for spl Routines (cont.)

spl Routine	Meaning
splx	Resets the CPU priority to the level specified by the argument.
splnone	Unmasks (enables) all interrupts.

The `spl` routines set the CPU priority to various interrupt levels. The current CPU priority level determines which types of interrupts are masked (disabled) and which are unmasked (enabled). Historically, seven levels of interrupts were supported, with eight different `spl` routines to handle the possible cases. For example, calling `spl0` would unmask all interrupts and calling `spl7` would mask all interrupts. Calling an `spl` routine between 0 and 7 would mask all interrupts at that level and at all lower levels.

Specific interrupt levels were assigned for different device types. For example, before handling a given interrupt, a kernel module would set the CPU priority level to mask all other interrupts of the same level or lower. This setting meant that the kernel module could be interrupted only by interrupt requests from devices of a higher priority.

The operating system currently supports the naming of `spl` routines to indicate the associated device types. Named `spl` routines make it easier to determine which routine you should use to set the priority level for a given device type.

The following code fragment shows the use of `spl` routines as part of a disk strategy routine:

```
:\n:\nint s;\n:\ns = splbio(); ①\n:\n[Code to deal with data that can be modified by the disk interrupt\ncode]\nsplx(s); ②\n:\n:\n
```

① Calls the `splbio` routine to mask (disable) all disk interrupts. This routine does not take an argument.

② Calls the `splx` routine to reset the CPU priority to the level specified by the `s` argument. Note that the one argument associated with `splx` is a CPU priority level, which in the example is the value returned by `splbio`. (The `splx` routine is the only one of the `spl` routines that takes an argument.) Upon successful completion, each `spl` routine

returns an integer value that represents the CPU priority level that existed before it was changed by a call to the specified `spl` routine.

5.3.7 Allocating Memory

A kernel module may need to declare a significant number of data structures to contain a large amount of data. For example, a kernel module that is a device driver may need to support a large number of disks and controllers. Statically allocating the maximum number of data structures would be a waste of space. Dynamically allocating memory for the required data structures is a better use of system resources. This is especially the case when working with temporary or transient data.

To dynamically allocate memory, you need to:

- Use the `MALLOC` macro to allocate the data structures
- Use the `FREE` macro to free up the dynamically allocated data structures

The following sections describe these steps.

5.3.7.1 Allocating Data Structures with `MALLOC`

Use the `MALLOC` macro to dynamically allocate a variable-size section of kernel virtual memory. The `MALLOC` macro maintains a pool of preallocated memory for quick allocation and returns the address of the allocated memory. The `MALLOC` macro is actually a wrapper that calls `malloc`. A kernel module should not directly call the `malloc` routine.

The syntax for the `MALLOC` macro is as follows:

```
MALLOC(  
    addr,  
    cast,  
    u_long size,  
    int type,  
    int flags );
```

Call the `MALLOC` macro with the following parameters:

`addr`

Specifies the memory location that points to the allocated memory. You specify the `addr` argument's data type in the `cast` argument.

`cast`

Specifies the data type of the `addr` argument and the type of the memory pointer returned by `MALLOC`.

size

Specifies the size in bytes of the memory to allocate. Typically, you pass the size as a constant to speed up the memory allocation.

type

Specifies the purpose for which the memory is being allocated. The memory types are defined in the file `sys/malloc.h`. Typically, kernel modules use the constant `M_DEVBUFF` to indicate that kernel module memory is being allocated (or freed).

flags

Specifies one of the following flag constants defined in `/usr/sys/include/sys/malloc.h`:

`M_WAITOK` Allocates memory from the virtual memory subsystem if there is not enough memory in the preallocated pool. This constant signifies that `MALLOC` can block.

`M_NOWAIT` Does not allocate memory from the virtual memory subsystem if there is not enough memory in the preallocated pool. This constant signifies that `MALLOC` cannot block. `M_NOWAIT` must be used when calling `MALLOC` from an interrupt context or if the caller is holding a simple lock. Otherwise, a system panic will occur.

`M_ZERO` Allocates zero-filled memory. You pass this bit value to `M_WAITOK` or `M_NOWAIT`.

The following example illustrates how to allocate memory using the `MALLOC` macro:

```
struct foo *foo1;
struct foo *foo2;
struct bar *bar[];
:
:
MALLOC(foo1, struct foo *, sizeof(struct foo),
M_DEVBUFF, M_NOWAIT|M_ZERO);[1]

if (!foo1) {
:
:
return;[2]
}
```



```

:
:
MALLOC(foo2, struct foo *,
nfoo * sizeof(struct foo), M_DEVBUFF,
M_WAITOK|M_ZERO);3
:
:
MALLOC(bar, struct bar **,
nbar * sizeof(struct bar *), M_DEVBUFF,
M_WAITOK|M_ZERO);4
:
:
MALLOC(bar[1], struct bar *, sizeof(struct bar),
M_DEVBUFF, M_WAITOK|M_ZERO);5

```

- 1** Allocates a single data structure.
- 2** Because `M_NOWAIT` is specified, checks the return value to see if the allocation failed.
- 3** Allocates an array of structures with `nfoo` elements.
- 4** Allocates an array of pointers to structures.
- 5** Allocates a structure to the second element of `bar`.

5.3.7.2 Freeing Up Dynamically Allocated Memory

When a block of memory allocated through `MALLOC` is no longer needed it, free it back to the system using the `FREE` macro. The `FREE` macro takes two arguments:

- The first argument specifies the memory pointer that points to the allocated memory to be freed. You must have previously set this argument in the call to `MALLOC`.
- The second argument specifies the purpose for which the memory is being allocated. The memory types are defined in the file `/usr/sys/include/sys/malloc.h`. Typically, kernel modules that are device drivers use the constant `M_DEVBUFF` to indicate that memory is being allocated (or freed).

The following example shows how to use the `FREE` macro:

```

FREE(foo1, M_DEVBUFF);

/*
 * Free the second element from the array of pointers
 */
FREE(bar[1], M_DEVBUFF);
bar[1] = NULL;

```

5.4 Working with System Time

This section describes considerations for working with system time. Information in this section explains the following concepts:

- Understanding system time concepts
- Fetching time
- Modifying a timestamp
- Enabling an application to convert time to a string
- Delaying a routine a specified number of microseconds

5.4.1 Understanding System Time Concepts

This section discusses concepts for working with system time:

- How a kernel module fetches or modifies time
- How time is created

5.4.1.1 How a Kernel Module Uses Time

Kernel modules can save timestamps that can be passed to applications on request for many purposes. For example:

- When a bus was last scanned
- When the last error on a disk occurred
- When the last interrupt for the some device (for example, a line printer) occurred
- When the system booted
- When the file system was mounted on a particular disk

The application then needs to print the date and time. Your kernel module code must determine several things for each timestamp it wants to preserve:

- When it needs to fetch time
- Whether or not the time value that was fetched needs modification to reflect accurate time
- How to pass the time value to the application

5.4.1.2 How Is System Time Created?

System time, which is platform-dependent, is defined as ticks of the system clock, measured as units of hertz (hz). The operating system makes system time available to kernel modules. The representation of system time is not based on the current calendar time of day because the actual time value does not become available to the operating system until you are partially through the boot sequence.

From the beginning of a boot sequence to dispatch point `CFG_PT_TOPOLOGY_CONF`, the operating system time value is 0 (zero). In Tru64 UNIX, zero is equivalent to January 1, 1970, 00:00:00, UTC. At dispatch point `CFG_PT_TOPOLOGY_CONF`, the operating system begins incrementing system time from zero. Later, at the dispatch point `CFG_PT_ROOT_FS_AVAIL`, system time is set to the actual time of day.

The time between `CFG_PT_TOPOLOGY_CONF` and `CFG_PT_ROOT_FS_AVAIL` is called the **boot delta**. Figure 5–9 illustrates these concepts.

Figure 5–9: When Time Becomes Available During a System Boot

Boot Timeline

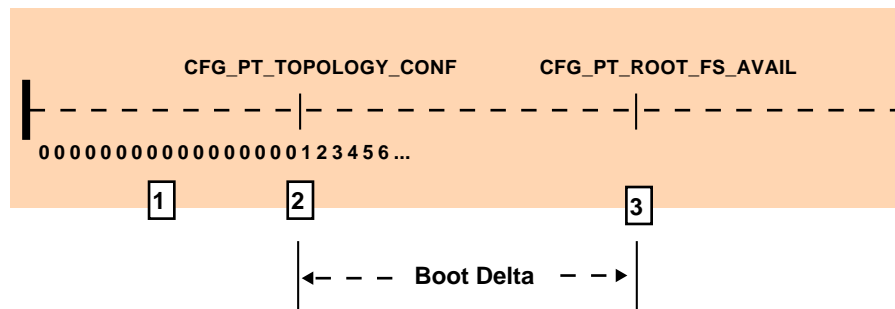

ZK-1566U-AI

- ❶ At the start of a boot sequence, the value is 0 (zero).
- ❷ At `CFG_PT_TOPOLOGY_CONF`, the kernel starts incrementing time. The initial date and time is recorded as 00:00:00 UTC 1 Jan 1970 (the Epoch).
- ❸ At `CFG_PT_ROOT_FS_AVAIL`, the kernel sets the time to the correct calendar date and time.

If your kernel module fetches time before `CFG_PT_ROOT_FS_AVAIL` is reached, the time value it fetches is incorrect and you will need to modify that timestamp later on (see Section 5.4.3).

5.4.2 Fetching System Time

A kernel module decides when to fetch system time. When it performs a fetch operation, it also needs a way to fetch system time. The `TIME_READ` macro provides a way for your kernel module to fetch the current time. The following code fragment shows how to use this macro in your kernel module:

```
#include <sys/time.h>❶
:
extern struct timeval time;❷
```

```

:
:
{ struct timeval my_time;3
:
:
TIME_READ(my_time);4

```

- ❶ Includes the `time.h` header file.
- ❷ Declares the global time variable as external.
- ❸ Declares your own storage for your timestamp.
- ❹ Fetches the current time and stores it in your own time variable using the `TIME_READ` macro. `TIME_READ` takes one parameter, which specifies the memory location to store the current time. Its type is `struct timeval`.

5.4.3 Modifying a Timestamp

If your kernel module fetches time prior to the operating system setting the current time at `CFG_PT_ROOT_FS_AVAIL`, you must modify the timestamp you fetched and stored. For example, assume your kernel module keeps track of when it last scanned the bus. Because scanning the bus takes place prior to `CFG_PT_ROOT_FS_AVAIL`, the fetched time is interpreted as approximately Jan. 1, 1970, 00:00:00. (This is because time was not set to the proper value when you fetched it.) The global variable `bootdelta` keeps track of how many seconds and microseconds have been counted between the two configuration points.

Perform these steps to modify a timestamp:

1. Register a callback for `CFG_PT_ROOT_FS_AVAIL` in your kernel module.
2. Use the following algorithm to modify the timestamp:
 - Subtract the number of seconds (`tv_sec`) and microseconds (`tv_usec`) that were counted before time was set to the actual time.
 - Add the number of seconds and microseconds that were counted to the point where the kernel module fetched time.

The following code example subtracts `bootdelta` seconds and adds `my_time` seconds:

```

#include <sys/time.h>
:
:
extern struct timeval bootdelta;
:
:
struct timeval temp_time;

```

```

TIME_READ(temp_time);1
:
temp_time.tv_sec -= (bootdelta.tv_sec - my_time.tv_sec);2

if (bootdelta.tv_usec > temp_time.tv_usec) {
    temp_time.tv_usec = 1000000 -
        (bootdelta.tv_usec - temp_time.tv_usec);
    temp_time.tv_sec--;
} else {
    temp_time.tv_usec -= bootdelta.tv_usec;3
}
:
temp_time.tv_usec += my_time.tv_usec;4

if (temp_time.tv_usec >= 1000000) {
    temp_time.tv_usec -= 1000000;
    temp_time.tv_sec++;5
}
:
my_time = temp_time;6

```

- ¹ Obtains the current time, which should be set to the actual time of day.
- ² Subtracts `bootdelta` seconds from the current time and adds the number of seconds in the timestamp.
- ³ Subtracts `bootdelta` microseconds; make sure its value is not negative.
- ⁴ Adds `my_time` microseconds.
- ⁵ Fixes any microseconds that may have wrapped.
- ⁶ Stores the results into the time variable.

5.4.4 Enabling Applications to Convert a Kernel Timestamp to a String

A user application can receive a timestamp from a kernel module in a variety of ways. The standard way is for a kernel module to pass a timestamp to the application as a `struct timeval`.

For an application to convert the timestamp it received from the kernel module, it uses the `ctime` function defined in `/usr/include/sys/time.h`. This function converts time values between `tm` structures, `time_t` type variables, and strings.

The `ctime` function expresses time in units by converting the `time_t` variable pointed to by the `timer` parameter into a string with the 5-field format. The `time_t` variable, also defined in `/usr/include/sys/time.h`, contains the number of seconds since the Epoch, 00:00:00 UTC 1 Jan 1970. For example:

```
Tue Nov 9 15:37:29 1998
```

For more information on converting timestamps to strings, see the reference page for `ctime(3)`.

5.4.5 Delaying the Calling Routine a Specified Number of Microseconds

To delay the calling routine a specified number of microseconds, use the `DELAY` macro. The following code fragment shows how to use this macro:

```
:\n:\nDELAY(10000) [1]\n:\n:
```

- [1] Shows that the `DELAY` macro takes one argument: the number of microseconds for the calling thread to spin.

The `DELAY` macro delays the routine a specified number of microseconds. `DELAY` spins, waiting for the specified number of microseconds to pass before continuing execution. The example shows a 10000-microsecond (10-millisecond) delay. The range of delays is system dependent, due to its relation to the granularity of the system clock. The system defines the number of clock ticks per second in the `hz` variable. Specifying any value smaller than $1/hz$ to the `DELAY` macro results in an unpredictable delay. For any delay value, the actual delay may vary by plus or minus one clock tick.

Using the `DELAY` macro is discouraged because the processor will be consumed for the specified time interval and therefore is unavailable to service other threads. In cases where kernel modules need timing mechanisms, you should use the `sleep` and `timeout` routines instead of the `DELAY` macro. The most common usage of the `DELAY` macro is in the system boot path. Using `DELAY` in the boot timeline is often acceptable because there are no other threads in contention for the processor.

5.5 Using Kernel Threads

A kernel thread is a single sequential flow of control within a kernel module or other systems-based program. The kernel module or other systems-based program makes use of the routines (instead of a threads library package such as `DECthreads`) to start, terminate, and delete threads, and perform other kernel thread operations.

Kernel threads execute within (and share) a single address space. Therefore, kernel threads read and write to the same memory locations.

You use kernel threads to improve the performance of a kernel module. Multiple kernel threads are useful in a multiprocessor environment, where

kernel threads run concurrently on separate CPUs. However, multiple kernel threads also improve kernel module performance on single-processor systems by permitting the overlap of input, output, or other slow operations with computational operations.

Kernel threads allow kernel modules to perform other useful work while waiting for a device to produce its next event, such as the completion of a disk transfer or the receipt of a packet from the network. For more information on using kernel threads, see Chapter 9.

5.6 Using Locks

In a single-processor environment, kernel modules need not protect the integrity of a resource from activities resulting from the actions of another CPU. However, in a symmetric multiprocessing (SMP) environment, the kernel module must protect (lock) the resource from multiple CPU access to prevent corruption. A resource, from the kernel module's standpoint, is data that more than one kernel thread can manipulate. Locks are the mechanism for sharing resources in an SMP environment.

See Chapter 6 for an overview of symmetric multiprocessing and the two locking methods you can use when your kernel modules execute in an SMP environment. Chapter 7 provides information for using simple locks in your kernel module. Chapter 8 provides information for using complex locks.

6

Symmetric Multiprocessing and Locking Methods

Symmetric multiprocessing (SMP) describes a computer environment that uses two or more central processing units (CPUs). In an SMP environment, software applications and the associated kernel modules can operate on two or more of these CPUs. To ensure the integrity of the data manipulated by kernel modules in this multiprocessor environment, you must perform additional design and implementation tasks beyond those discussed in *Writing Device Drivers*. One of these tasks involves choosing a locking method. Tru64 UNIX provides you with two methods to write SMP-safe kernel modules: **simple locks** and **complex locks**.

This chapter discusses the information you need to decide which items (variables, data structures, and code blocks) must be locked in the kernel module and to choose the appropriate method (simple locks or complex locks). Specifically, the chapter describes the following topics associated with designing and developing a kernel module that can operate safely in an SMP environment:

- Understanding hardware issues related to synchronization
- Understanding the need for locking in an SMP environment
- Comparing simple locks and complex locks
- Choosing a locking method
- Choosing the resources to lock in a kernel module

The following sections discuss each of these topics. You do not need an intimate understanding of kernel threads to learn about writing kernel modules in an SMP environment. Chapter 9 of this book discusses kernel threads and the associated routines that kernel modules use to create and manipulate them.

6.1 Understanding Hardware Issues Related to Synchronization

Alpha CPUs provide several features to assist with hardware-level synchronization. Even though all instructions that access memory are

noninterruptible, no single one performs an atomic read-modify-write operation. A kernel-mode thread of execution can raise the interrupt priority level (IPL) in order to block other kernel threads on that CPU while it performs a read-modify-write sequence or while it executes any other group of instructions. Code that runs in any access mode can execute a sequence of instructions that contains load-locked (LDx_L) and store-conditional (STx_C) instructions to perform a read-modify-write sequence that appears atomic to other kernel threads of execution.

Memory barrier instructions order a CPU's memory reads and writes from the viewpoint of other CPUs and I/O processors. The locking mechanisms (simple and complex locks) provided in the operating system take care of the idiosyncracies related to read-modify-write sequences and memory barriers on Alpha CPUs. Therefore, you need not be concerned about these hardware issues when implementing SMP-safe kernel modules that use simple and complex locks.

The rest of this section describes the following hardware-related issues:

- Atomicity
- Alignment
- Granularity

6.1.1 Atomicity

Software synchronization refers to the coordination of events in such a way that only one event happens at a time. This kind of synchronization is a serialization or sequencing of events. Serialized events are assigned an order and processed one at a time in that order. While a serialized event is being processed, no other event in the series is allowed to disrupt it.

By imposing order on events, software synchronization allows reading and writing of several data items indivisibly, or atomically, to obtain a consistent set of data. For example, all of process A's writes to shared data must happen before or after process B's writes or reads, but not during process B's writes or reads. In this case, all of process A's writes must happen indivisibly for the operation to be correct. This includes process A's updates — reading of a data item, modifying it, and writing it back (read-modify-write sequence). Other synchronization techniques ensure the completion of an asynchronous system service before the caller tries to use the results of the service.

Atomicity is a type of serialization that refers to the indivisibility of a small number of actions, such as those occurring during the execution of a single instruction or a small number of instructions. With more than one action, no single action can occur by itself. If one action occurs, then all the

actions occur. Atomicity must be qualified by the viewpoint from which the actions appear indivisible: an operation that is atomic for kernel threads running on the same CPU can appear as multiple actions to a kernel thread of execution running on a different CPU.

An atomic memory reference results in one indivisible read or write of a data item in memory. No other access to any part of that data can occur during the course of the atomic reference. Atomic memory references are important for synchronizing access to a data item that is shared by multiple writers or by one writer and multiple readers. References need not be atomic to a data item that is not shared or to one that is shared but is only read.

6.1.2 Alignment

Alignment refers to the placement of a data item in memory. For a data item to be naturally aligned, its lowest-addressed byte must reside at an address that is a multiple of the size of the data item (in bytes). For example, a naturally aligned longword has an address that is a multiple of 4. The term *naturally aligned* is usually shortened to “aligned.”

An Alpha CPU allows atomic access only to an aligned longword or an aligned quadword. Reading or writing an aligned longword or quadword of memory is atomic with respect to any other kernel thread of execution on the same CPU or on other CPUs.

6.1.3 Granularity

The phrase **granularity** of data access refers to the size of neighboring units of memory that can be written independently and atomically by multiple CPUs. Regardless of the order in which the two units are written, the results must be identical.

Alpha systems have longword and quadword granularity. That is, only adjacent aligned longwords or quadwords can be written independently. Because Alpha systems support only instructions that load or store longword-sized and quadword-sized memory data, the manipulation of byte-sized and word-sized data on Alpha systems requires that the entire longword or quadword that contains the byte- or word-sized item be manipulated. Thus, simply because of its proximity to an explicitly shared data item, neighboring data might become shared unintentionally. Manipulation of byte-sized and word-sized data on Alpha systems requires multiple instructions that:

1. Fetch the longword or quadword that contains the byte or word
2. Mask the nontargeted bytes

3. Manipulate the target byte or word
4. Store the entire longword or quadword

Because this sequence is interruptible, operations on byte and word data are not atomic on Alpha systems. Also, this change in the granularity of memory access can affect the determination of which data is actually shared when a byte or word is accessed.

The absence of byte and word granularity on Alpha systems has important implications for access to shared data. In effect, any memory write of a data item other than an aligned longword or quadword must be done as a multiple-instruction read-modify-write sequence. Also, because the amount of data read and written is an entire longword or quadword, you must ensure that all accesses to fields within the longword or quadword are synchronized with each other.

6.2 Locking in a Symmetric Multiprocessing Environment

In a single-processor environment, kernel modules need not protect the integrity of a resource from activities resulting from the actions of another CPU. However, in an SMP environment, the kernel module must protect the resource from multiple CPU access to prevent corruption. A resource, from the kernel module's standpoint, is data that more than one kernel thread can manipulate. You can store the resource in variables (global) and in data structure fields. The top half of Figure 6-1 shows a typical problem that could occur in an SMP environment. The figure shows that the resource called *i* is a global variable whose initial value is 1.

Furthermore, the figure shows that the kernel threads emanating from CPU1 and CPU2 increment resource *i*. A kernel thread is a single sequential flow of control within a kernel module or other systems-based program. The kernel module or other systems-based program makes use of the routines (instead of a threads library package such as DECthreads) to start, terminate, delete, and perform other kernel threads-related operations. These kernel threads cannot increment this resource simultaneously. Without some way to lock the global variable when one kernel thread is incrementing it, the integrity of the data stored in this resource is compromised in the SMP environment.

To protect the integrity of the data, you must enforce order on the accesses of the data by multiple CPUs. One way to establish the order of CPU access to the resource is to establish a lock. As the bottom half of the figure shows, the kernel thread emanating from CPU1 locks access to resource *i*, thus preventing access by kernel threads emanating from CPU2. This guarantees the integrity of the value stored in this resource.

Figure 6–1: Why Locking Is Needed in an SMP Environment

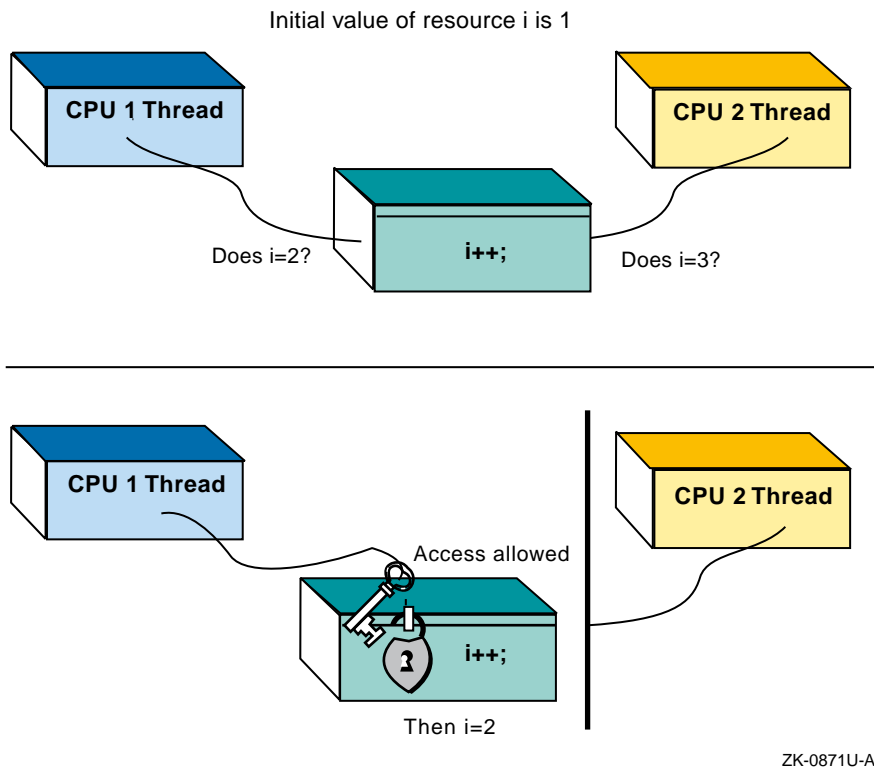

The vertical line in the bottom half of the figure represents a barrier that prevents the kernel thread emanating from CPU2 from accessing resource i until the kernel thread emanating from CPU1 unlocks it. For simple locks, this barrier indicates that the lock is exclusive. That is, no other kernel thread can gain access to the lock until the kernel thread currently controlling it has released (unlocked) it.

For complex write locks, this barrier represents a wait hash queue that collects all of the kernel threads waiting to gain write access to a resource. With complex read locks, all kernel threads have read-only access to the same resource at the same time.

6.3 Comparing Simple Locks and Complex Locks

The operating system provides two ways to lock specific resources (global variables and data structures) referenced in code blocks in the kernel module: simple locks and complex locks. Simple and complex locks allow kernel modules to:

- Synchronize access to a resource or resources. This means kernel threads emanating from multiple CPUs can safely update the count of global variables, add elements to or delete elements from linked lists, and update or read time elements.
- Ensure a consistent view of state transitions (run to block and block to run) across multiple CPUs.
- Make the operating system behave as though it were running on a single CPU.

The following sections briefly describe simple locks and complex locks.

6.3.1 Simple Locks

A simple lock is a general-purpose mechanism for protecting resources in an SMP environment. Figure 6–2 shows that simple locks are spin locks. That is, the routines used to implement the simple lock do not return until the lock has been obtained.

As the figure shows, the CPU1 kernel thread obtains a simple lock on resource *i*. Once the CPU1 kernel thread obtains the simple lock, it has exclusive access over the resource to perform read and write operations on the resource. The figure also shows that the CPU2 kernel thread spins while waiting for the CPU1 kernel thread to unlock (free) the simple lock.

Figure 6–2: Simple Locks Are Spin Locks

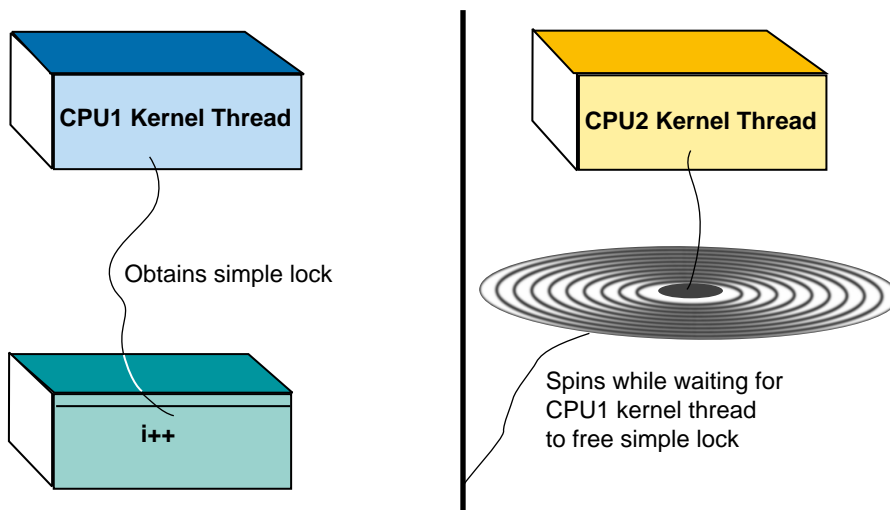

ZK-0957U-AI

You need to understand the tradeoffs in performance and realtime preemption latency associated with simple locks before you use them. However, sometimes kernel modules must use simple locks. For example, kernel modules must use simple locks and `spl` routines to synchronize with interrupt service routines. Section 6.4 provides guidelines to help you choose between simple locks and complex locks.

Table 6–1 lists the data structure and routines associated with simple locks. Chapter 7 discusses how to use the data structure and routines to implement simple locks in a kernel module.

Table 6–1: Data Structure and Routines Associated with Simple Locks

Structure/Routines	Description
<code>slock</code>	Contains simple lock–specific information.
<code>decl_simple_lock_data</code>	Declares a simple lock structure.
<code>simple_lock</code>	Asserts a simple lock.
<code>simple_lock_init</code>	Initializes a simple lock structure.
<code>simple_lock_terminate</code>	Terminates, using a simple lock.
<code>simple_lock_try</code>	Tries to assert a simple lock.
<code>simple_unlock</code>	Releases a simple lock.

6.3.2 Complex Locks

A complex lock is a mechanism for protecting resources in an SMP environment. A complex lock achieves the same results as a simple lock. However, kernel modules should use complex locks (not simple locks) if there are blocking conditions.

The routines that implement complex locks synchronize access to kernel data between multiple kernel threads. The following describes characteristics associated with complex locks:

- Multiple reader access
- Thread blocking (sleeping) if the write lock is asserted

Figure 6–3 shows that complex locks are not spin locks, but blocking (sleeping) locks. That is, the routines that implement the complex lock block (sleep) until the lock is released. Thus, unlike simple locks, you should not use complex locks to synchronize with interrupt service routines. Because of the blocking characteristic of complex locks, they are active on both single and multiple CPUs to serialize access to data between kernel threads.

As the figure shows, the CPU1 kernel thread asserts a complex lock with write access on resource *i*. The CPU2 kernel thread also asserts a complex lock with write access on resource *i*. Because the CPU1 kernel thread asserts the write complex lock on resource *i* first, the CPU2 kernel thread blocks, waiting until the CPU1 kernel thread unlocks (frees) the complex write lock.

Figure 6–3: Complex Locks Are Blocking Locks

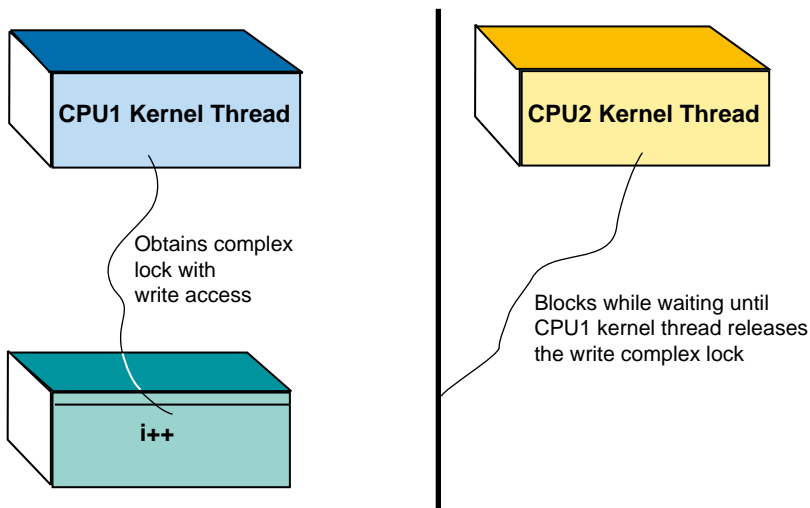

ZK-0956U-AI

Like simple locks, complex locks present tradeoffs in performance and realtime preemption latency that you should understand before you use them. However, sometimes kernel modules must use complex locks. For example, kernel modules must use complex locks when there are blocking conditions in the code block. On the other hand, you must not take a complex lock while holding a simple lock or when using the `timeout` routine. Section 6.4 provides guidelines to help you choose between simple locks and complex locks.

Table 6-2 lists the data structure and routines associated with complex locks. Chapter 8 discusses how to use the data structure and routines to implement complex locks in a kernel module.

Table 6-2: Data Structure and Routines Associated with Complex Locks

Structure/Routines	Description
<code>lock</code>	Contains complex lock-specific information.
<code>lock_done</code>	Releases a complex lock.
<code>lock_init</code>	Initializes a complex lock.
<code>lock_read</code>	Asserts a complex lock with read-only access.
<code>lock_terminate</code>	Terminates, using a complex lock.
<code>lock_try_read</code>	Tries to assert a complex lock with read-only access.
<code>lock_try_write</code>	Tries to assert a complex lock with write access.
<code>lock_write</code>	Asserts a complex lock with write access.

6.4 Choosing a Locking Method

You can make your kernel modules SMP-safe by implementing a simple or complex locking method.

This section provides guidelines to help you choose the appropriate locking method (simple or complex). In choosing a locking method, consider the following SMP characteristics:

- Who has access to a particular resource
- Prevention of access to the resource while a kernel thread sleeps
- Length of time the lock is held
- Execution speed

- Size of code blocks

The following sections discuss each of these characteristics. See Section 6.4.6 for a summary comparison table of the locking methods that you can use to determine which items to lock in your kernel modules.

6.4.1 Who Has Access to a Particular Resource

To choose the appropriate lock method, you must understand the entity that has access to a particular resource. Possible entities that can access a resource are kernel threads, interrupt service routines, and exceptions. If you need a lock for resources accessed by multiple kernel threads, use simple or complex locks. Use a combination of `sp1` routines and simple locks to lock resources that kernel threads and interrupt service routines access.

For exceptions, use complex locks if the exception involves blocking conditions. If the exception does not involve blocking conditions, you can use simple locks.

6.4.2 Prevention of Access to a Resource While a Kernel Thread Sleeps

You must determine if it is necessary to prevent access to the resource while a kernel thread blocks (sleeps). One example is waiting for disk I/O to a buffer. If you need a lock to prevent access to the resource while a kernel thread blocks (sleeps) and there are no blocking conditions, use simple or complex locks. Otherwise, if there are blocking conditions, use complex locks.

6.4.3 Length of Time the Lock Is Held

You must estimate the length of time the lock is held to determine the appropriate lock method. In general, use simple locks when the entity accesses are bounded and small. One example of a bounded and small access is some entity accessing a system time variable. Use complex locks when the entity accesses could take a long time or a variable amount of time. One example of a variable amount of time is some entity scanning linked lists.

6.4.4 Execution Speed

You must account for execution speed in choosing the appropriate lock method. The following factors influence execution speed:

- The way complex locks work
Complex locks are slightly more than twice as expensive (in terms of execution speed) as simple locks. The reason for this is that complex locks use the simple lock routines to implement the lock. Thus, it takes two lock and unlock pairs to protect a resource or code block with a complex lock as opposed to one pair for the simple lock.
- Memory space used
Complex locks use more memory space than simple locks. The reason for this is that the complex lock structure, `lock`, contains a pointer to a simple lock structure in addition to other data to implement the complex lock.
- Busy wait time
Busy wait time is the amount of CPU time expended on waiting for a simple lock to become free. If the kernel module initiates a simple lock on a resource and the code block is long (or there are numerous interrupts), a lot of CPU time could be wasted waiting for the simple lock to become free. If this is the case, use complex locks to allow the current kernel thread to block (sleep) on the busy resource. This action allows the CPU to execute a different kernel thread.
- Realtime preemption
Realtime preemption cannot occur when a simple lock is held. Use of complex locks (which can block) improves the performance associated with realtime preemption.

6.4.5 Size of Code Blocks

In general, use complex locks for resources contained in long code blocks. Also, use complex locks in cases where the resource must be prevented from changing when a kernel thread blocks (sleeps).

Use simple locks for resources contained in short, nonblocking code blocks or when synchronizing with interrupt service routines.

6.4.6 Summary of Locking Methods

Table 6–3 summarizes the SMP characteristics for choosing the appropriate lock method to make your kernel module SMP safe. The first column of the table presents an SMP characteristic and the second and third columns present the lock methods.

The following list describes the possible entities that can appear in the second and third columns:

- **Yes** — Indicates that the lock method is suitable for the characteristic.
- **No** — Indicates that the lock method is not suitable for the characteristic.
- **Better** — Indicates that this lock method is the most suitable for the characteristic.
- **Worse** — Indicates that this lock method is not the most suitable for the characteristic.

(The numbers before each Characteristic item appear for easy reference in later descriptions.)

Table 6–3: SMP Characteristics for Locking

Characteristic	Simple Lock	Complex Lock
1. Kernel threads will access this resource.	Yes	Yes
2. Interrupt service routines will access this resource.	Yes	No
3. Exceptions will access this resource.	Yes	Yes
4. Need to prevent access to this resource while a kernel thread blocks and there are no blocking conditions.	Yes	Yes
5. Need to prevent access to this resource while a kernel thread blocks and there are blocking conditions.	No	Yes
6. Need to protect resource between kernel threads and interrupt service routines.	Yes	No
7. Need to have maximum execution speed for this kernel module.	Yes	No
8. The module references and updates this resource in long code blocks (implying that the length of time the lock is held on this resource is not bounded and long).	Worse	Better
9. The module references and updates this resource in short nonblocking code blocks (implying that the length of time the lock is held on this resource is bounded and short).	Better	Worse
10. Need to minimize memory usage by the lock-specific data structures.	Yes	No
11. Need to synchronize with interrupt service routines.	Yes	No

Table 6–3: SMP Characteristics for Locking (cont.)

Characteristic	Simple Lock	Complex Lock
12. The module can afford busy wait time.	Yes	No
13. The module implements realtime preemption.	Worse	Better

Use the following steps to analyze your kernel module to determine which items to lock and which locking method to choose:

1. Identify all of the resources in your kernel module that you could potentially lock. Section 6.5 discusses some of these resources.
2. Identify all of the code blocks in your kernel module that manipulate the resource.
3. Determine which locking method is appropriate. Use Table 6–3 as a guide to help you choose the locking method. Section 6.5.5 shows how to use this table for choosing a locking method for the example device register offset definition resources.
4. Determine the granularity of the lock. Section 6.5.5 shows how to determine the granularity of the locks for the example device register offset definitions.

6.5 Choosing the Resources to Lock in the Module

Section 6.4 presents the SMP characteristics you must consider when choosing a locking method. You need to analyze each section of the kernel module (in device drivers, for example, the open and close device section, the read and write device section, and so forth) and apply those SMP characteristics to the following resource categories:

- Read-only resources
- Device control status register (CSR) addresses
- Module-specific global resources
- System-specific global resources

The following sections discuss each of these categories. See Section 6.5.5 for an example that walks you through the steps for analyzing a kernel module to determine which resources to lock.

6.5.1 Read-Only Resources

Analyze each section of your kernel module to determine if the access to a resource is read only. In this case, resource refers to module and system

data stored in global variables or data structure fields. You do not need to lock resources that are read only because there is no way to corrupt the data in a read-only operation.

6.5.2 Device Control Status Register Addresses

Analyze each section of your kernel module to determine accesses to a device's control status register (CSR) addresses. Many kernel modules based on the UNIX operating system use the direct method; that is, they access a device's CSR addresses directly through a device register structure. This method involves declaring a device register structure that describes the device's characteristics, which include a device's control status register. After declaring the device register structure, the kernel module accesses the device's CSR addresses through the field that maps to it.

Some CPU architectures do not allow you to access the device CSR addresses directly. Kernel modules that need to operate on these types of CPUs should use the indirect method. In fact, kernel modules operating on Alpha systems must use the indirect method. Thus, the discussion of locking a device's CSR addresses focuses on the indirect method.

The indirect method involves defining device register offset definitions (instead of a device register structure) that describe the device's characteristics, which include a device's control status register. The method also includes the use of the following categories of routines:

- CSR I/O access routines

`read_io_port` – Reads data from a device register
`write_io_port` – Writes data to a device register

- I/O copy routines

`io_copyin` – Copies data from bus address space to system memory
`io_copyio` – Copies data from bus address space to bus address space
`io_copyout` – Copies data from system memory to bus address space

Using these routines makes your kernel module more portable across different bus architectures, different CPU architectures, and different CPU types within the same architecture. For examples of how to use these routines when writing device drivers, see *Writing Device Drivers*. The following example shows the device register offset definitions that some `xx` kernel module defines for some `XX` device:

```
⋮  
#define XX_ADDDER 0x0 /* 32-bit read/write DMA address register */
```

```

#define XX_DATA 0x4 /* 32-bit read/write data register */
#define XX_CSR 0x8 /* 16-bit read/write CSR/LED register */
#define XX_TEST 0xc /* Go bit register. Write sets. Read clears */
:
:

```

6.5.3 Module-Specific Global Resources

Analyze the declarations and definitions sections of your kernel module to identify the following global resources:

- Module-specific global variables
- Module-specific data structures

Module-specific global variables can store a variety of information, including flag values that control execution of code blocks and status information. The following example shows the declaration and initialization of some typical module-specific global variables. Use this example to help you locate similar module-specific global variables in your kernel module.

```

:
:
int num_xx = 0;
:
:
int xx_is_dynamic = 0;
:
:

```

Module-specific data structures contain fields that can store such information as whether a device is attached, whether it is opened, the read/write mode, and so forth. The following example shows the declaration and initialization of some typical module-specific data structures. Use this example to help you locate similar module-specific data structures in your kernel modules.

```

:
:
struct driver xxdriver = {
:
:
};
:
:
cfg_subsys_attr_t xx_attributes[] = {
:
:
};
:
:
};
:
:
struct xx_kern_str {
:
:

```

```

} xx_kern_str[NXX];
:
:
struct cdevsw xx_cdevsw_entry = {
:
:
};

```

After you identify the module-specific global variables and module-specific data structures, locate the code blocks in which the kernel module references them. Use Table 6-3 to determine which locking method is appropriate. Also, determine the granularity of the lock.

6.5.4 System-Specific Global Resources

Analyze the declarations and definitions sections of your kernel module to identify the following global resources:

- System-specific global variables
- System-specific data structures

System-specific variables include the global variables *hz*, *cpu*, and *lbolt*. The following example shows the declaration of one system-specific global variable:

```

:
:
extern int hz;
:
:

```

System-specific data structures include *controller*, *buf*, and *ihandler_t*. The following example shows the declaration of some system-specific data structures:

```

:
:
struct controller *info[NXX];
:
:
struct buf cbbuf[NCB];
:
:

```

After you identify the system-specific global variables and system-specific data structures, locate the code blocks in which the module references them. Use Table 6-3 to determine which locking method is appropriate. Also, determine the granularity of the lock.

Note

To lock `buf` structure resources, use the `BUF_LOCK` and `BUF_UNLOCK` routines instead of the simple and complex lock routines. For descriptions of these routines, see the `BUF_LOCK(9)` and `BUF_UNLOCK(9)` reference pages.

6.5.5 How to Determine the Resources to Lock

Use the following steps to determine which resources to lock in your kernel modules:

1. Identify all resources that you might lock.
2. Identify all of the code blocks in the kernel module that manipulate each resource.
3. Determine which locking method is appropriate.
4. Determine the granularity of the lock.

The following example walks you through an analysis of which resources to lock for the `xx` module.

Step 1: Identify All Resources That You Might Lock

Table 6–4 summarizes the resources that you might lock in your kernel module according to the following categories:

- Device control status register (CSR) addresses
- Module-specific global variables
- Module-specific data structures
- System-specific global variables
- System-specific global data structures

Table 6–4: Kernel Module Resources for Locking

Category	Associated Resources
Device control status register (CSR) addresses.	N/A
Module-specific global variables.	Variables that store flag values to control execution of code blocks. Variables that store status information.

Table 6–4: Kernel Module Resources for Locking (cont.)

Category	Associated Resources
Module-specific global data structures.	<i>dsent</i> , <i>cfg_subsys_attr_t</i> , <i>driver</i> , and the kernel module's <i>kern_str</i> structure.
System-specific global variables	<i>cpu</i> , <i>hz</i> , <i>lbolt</i> , and <i>page_size</i> .
System-specific global data structures	<i>controller</i> and <i>buf</i> .

One resource that the *xx* module must lock is the device CSR addresses. This module also needs to lock the *hz* global variable. The example analysis focuses on the following device register offset definitions for the *xx* module:

```
:\n#define XX_ADDER 0x0 /* 32-bit read/write DMA address register */\n#define XX_DATA 0x4 /* 32-bit read/write data register */\n#define XX_CSR 0x8 /* 16-bit read/write CSR/LED register */\n#define XX_TEST 0xc /* Go bit register. Write sets. Read clears */\n:\n
```

Step 2: Identify All of the Code Blocks in the Module That Manipulate the Resource

Identify all of the code blocks that manipulate the resource. If the code block accesses the resource read only, you may not need to lock the resources that it references. However, if the code block writes to the resource, you need to lock the resource by calling the simple or complex lock routines.

The *xx* module accesses the device register offset definition resources in the open and close device section and the read and write device section.

Step 3: Determine Which Locking Method Is Appropriate

Table 6–5 shows how to analyze the locking method that is most suitable for the device register offset definitions for some *xx* module. (The numbers before each Characteristic item appear for easy reference in later descriptions.)

Table 6–5: Locking Device Register Offset Definitions

Characteristic	Applies to This Module	Simple Lock	Complex Lock
1. Kernel threads will access this resource.	Yes	Yes	Yes
2. Interrupt service routines will access this resource.	No	N/A	N/A
3. Exceptions will access this resource.	No	N/A	N/A
4. Need to prevent access to this resource while a kernel thread blocks and there are no blocking conditions.	Yes	Yes	Yes
5. Need to prevent access to this resource while a kernel thread blocks and there are blocking conditions.	No	N/A	N/A
6. Need to protect resource between kernel threads and interrupt service routines.	Yes	Yes	No
7. Need to have maximum execution speed for this kernel module.	Yes	Yes	No
8. The module references and updates this resource in long code blocks (implying that the length of time the lock is held on this resource is not bounded and long).	No	N/A	N/A
9. The module references and updates this resource in short nonblocking code blocks (implying that the length of time the lock is held on this resource is bounded and short).	Yes	Better	Worse
10. Need to minimize memory usage by the lock-specific data structures.	Yes	Yes	No
11. Need to synchronize with interrupt service routines.	No	N/A	N/A
12. The module can afford busy wait time.	Yes	Yes	No
13. The module implements realtime preemption.	No	N/A	N/A

The locking analysis table for the device register offset definitions shows the following:

- Seven of the SMP characteristics (numbers 1, 4, 6, 7, 9, 10, and 12) apply to the `xx` module.
- Simple and complex locks are suitable for SMP characteristics 1 and 4.

- Simple locks are better suited than complex locks for SMP characteristic 9.
- Simple locks (not complex locks) are suitable for SMP characteristics 6, 7, 10, and 12.

Based on the previous analysis, the `xx` module uses the simple lock method.

Step 4: Determine the Granularity of the Lock

After choosing the appropriate locking method for the resource, determine the granularity of the lock. For example, in the case of the device register offset resource, you can determine the granularity by answering the following questions:

1. Is a simple lock needed for each device register offset definition?
2. Is one simple lock needed for all of the device register offset definitions?

Table 6–5 shows that the need to minimize memory usage is important to the `xx` module; therefore, creating one simple lock for all of the device register offset definitions would save the most memory. The following code fragment shows how to declare a simple lock for all of the device register offset definitions:

```

:
:
#include <kern/lock.h>
:
:
decl_simple_lock_data( , slk_xxdevoffset);
:
:

```

If the preservation of memory were not important to the `xx` module, declaring a simple lock for each device register offset definition might be more appropriate. The following code fragment shows how to declare a simple lock structure for each of the example device register offset definitions:

```

:
:
#include <kern/lock.h>
:
:
decl_simple_lock_data( , slk_xxaddr);
decl_simple_lock_data( , slk_xxdata);
decl_simple_lock_data( , slk_xxcsr);
decl_simple_lock_data( , slk_xxtest);
:
:

```

After declaring a simple lock structure for an associated resource, you must initialize it (only once) by calling `simple_lock_init`. You then use the simple lock routines in code blocks that access the resource. Chapter 7 discusses the simple lock–related routines.

7

Simple Lock Routines

After you decide that the simple lock method is the appropriate method for locking specific resources, you use the simple lock routines to accomplish the locking. To use simple locks in a kernel module, perform the following tasks:

- Declare a simple lock data structure
- Initialize a simple lock
- Assert exclusive access on a resource
- Release a previously asserted simple lock
- Try to obtain a simple lock
- Terminate a simple lock
- Use the `spl` routines with simple locks

To illustrate the use of these routines, the chapter uses code from an example kernel module called `xx` that operates on some `XX` device. This example module locks a `kern_str` structure resource called `xx_kern_str`.

7.1 Declaring a Simple Lock Data Structure

Before using a simple lock, declare a simple lock data structure for the resource you want to lock by using the `decl_simple_lock_data` routine. The following code fragment shows a call to `decl_simple_lock_data` in the `xx` kernel module:

```
:
:
#include <kern/lock.h> 1
:
:
struct xx_kern_str {
    int sc_openf; /* Open flag */
    int sc_count; /* Count of characters written to device */
    decl_simple_lock_data( , lk_xx_kern_str); /* SMP lock for xx_kern_str */
}xx_kern_str[NONE]; 2
:
:
```

- 1** Includes the header file `/usr/sys/include/kern/lock.h`. The `lock.h` file defines the simple spin lock and complex lock structures that kernel modules use for synchronization on single-processor and multiprocessor systems.

- ❷ Declares an array of `kern_str` structures and calls it `xx_kern_str`. The `xx` module uses the `decl_simple_lock_data` routine to declare a simple lock structure as a field of the `xx_kern_str` structure.

The `decl_simple_lock_data` routine declares a simple lock structure, `slock`, of the specified `name`. You declare a simple lock structure to protect kernel module data structures and device register access. You use `decl_simple_lock_data` to declare a simple lock structure and then pass it to the following simple lock-specific routines: `simple_lock_init`, `simple_lock`, `simple_lock_try`, `simple_unlock`, and `simple_lock_terminate`.

The `decl_simple_lock_data` routine can take two arguments:

- The first argument (not passed in this call) specifies the class of the declaration. For example, you pass the keyword `extern` if you want to declare the simple lock structure as an external structure. This argument would be specified in this call if `lk_xx_kern_str` was declared in another program module.
- The second argument specifies the name you want the `decl_simple_lock_data` routine to assign to the declaration of the simple lock structure. In this call to the routine, the name for the simple lock structure is `lk_xx_kern_str`.

You can also declare a simple lock structure by using the typedef `simple_lock_data_t`, as in the following example:

```
:
struct xx_kern_str {
    int sc_openf; /* Open flag */
    int sc_count; /* Count of characters written to device */
    simple_lock_data_t lk_xx_kern_str; /* SMP lock for xx_kern_str */
}xx_kern_str[NNONE]; ❶
```

- ❶ Declares an array of `kern_str` structures and calls it `xx_kern_str`. The `xx` module declares a simple lock structure as a field of the `xx_kern_str` structure to protect the integrity of the data stored in the `sc_openf` and `sc_count` fields. A kernel module's `kern_str` structure is one resource that often requires protection in an SMP environment because kernel module routines use it to share data. It is possible that more than one kernel thread might need to access the fields of an `xx_kern_str` structure.

7.2 Initializing a Simple Lock

After declaring the simple lock data structure, you initialize it by calling the `simple_lock_init` routine. The following code fragment shows a call

to `simple_lock_init` by the `xx` kernel module's `xxcattach` routine. The `xxcattach` routine performs the tasks necessary to establish communication with the actual device. One of these tasks is to initialize any global data structures. Thus, the `xxcattach` routine initializes the simple lock structure `lk_xx_kern_str`.

The code fragment also shows the declaration of the simple lock structure in the `xx_kern_str` structure.

```

:
:
#include <kern/lock.h> 1
:
:
struct xx_kern_str {
    int sc_openf; /* Open flag */
    int sc_count; /* Count of characters written to device */
    simple_lock_data_t lk_xx_kern_str; /* SMP lock for xx_kern_str */
}xx_kern_str[NNONE]; 2
:
:
:
xxcattach(struct controller *ctrl)
{
    register struct xx_kern_str *sc = &xx_kern_str[ctrl->ctrl_num];

    /* Tasks to perform controller-specific initialization */
    :
    :
simple_lock_init(&sc->lk_xx_kern_str); 3
    :
    :
    /* Perform any other controller-specific initialization tasks */
}

```

- 1** Includes the header file `/usr/sys/include/kern/lock.h`. The `lock.h` file defines the simple spin lock and complex lock structures that kernel modules use for synchronization on single-processor and multiprocessor systems.
- 2** Declares an array of `kern_str` structures and calls it `xx_kern_str`. The `xx` kernel module declares a simple lock structure as a field of the `xx_kern_str` structure to protect the integrity of the data stored in the `sc_openf` and `sc_count` fields. A kernel module's `kern_str` structure is one resource that often requires protection in an SMP environment because kernel module routines use it to share data. It is possible that more than one kernel thread might need to access the fields of an `xx_kern_str` structure.
- 3** Calls the `simple_lock_init` routine to initialize the simple lock structure called `lk_xx_kern_str`.

The `simple_lock_init` routine takes one argument: a pointer to a simple lock structure. You can declare this simple lock structure by using the `decl_simple_lock_data` routine. In this call, the `xxcattach` routine passes the address of the `lk_xx_kern_str` field of

the `xx_kern_str` structure pointer. You need to initialize the simple lock structure only once.

7.3 Asserting Exclusive Access on a Resource

After declaring and initializing the simple lock data structure, you can assert exclusive access by calling the `simple_lock` routine. The following code fragment shows a call to `simple_lock` by the `xx` kernel module's `xxopen` routine.

The `xxopen` routine is called as the result of an open system call.

The `xxopen` routine performs the following tasks:

- Checks to ensure that the open is unique
- Marks the device as open
- Returns the value 0 (zero) to the open system call to indicate success

The code fragment also shows the declaration of the simple lock structure in the `xx_kern_str` structure and the initialization of the simple lock structure by the module's `xxcattach` routine. See Section 7.2 for explanations of these tasks.

```

:
:
#include <kern/lock.h>
:
:
struct xx_kern_str {
    int sc_openf; /* Open flag */
    int sc_count; /* Count of characters written to device */
    simple_lock_data_t lk_xx_kern_str; /* SMP lock for xx_kern_str */
}xx_kern_str[NXX];
:
:
xxcattach(struct controller *ctrl)
{
    register struct xx_kern_str *sc = &xx_kern_str[ctrl->ctrl_num];

    /* Tasks to perform controller-specific initialization */
    :
    :
    simple_lock_init(&sc->lk_xx_kern_str);
    :
    :
}
:
:
xxopen(dev, flag, format)
dev_t dev;
int flag;
int format;

register int unit = minor(dev);
struct controller *ctrl = xxinfo[unit];
struct xx_kern_str *sc = &xx_kern_str[unit];
```



```

if(unit >= NXX)
    return ENODEV; 1
simple_lock(&sc->lk_xx_kern_str); 2
if (sc->sc_openf == DN_OPEN)
{
:
}

```

- 1** If the number of device units on the system is greater than `NXX`, returns the error code `ENODEV`, which indicates that no such device exists on the system. This example test is used to ensure that a valid device exists.
- 2** Calls the `simple_lock` routine to assert an exclusive access on the following code block.

The `simple_lock` routine takes one argument: a pointer to a simple lock structure. You can declare this simple lock structure by using the `decl_simple_lock_data` routine. In this call, the `xxopen` routine passes the address of the `lk_xx_kern_str` field of the `xx_kern_str` structure pointer.

Figure 7-1 shows what happens when two instances of the `xx` kernel module execute on two CPUs. As the figure shows, the kernel thread emanating from CPU1 obtains the simple lock on the code block that follows item 2 in the code fragment before the kernel thread emanating from CPU2. The reason for locking this code block is to prevent data corruption of any future writes to the `xx_kern_str` structure. The CPU2 kernel thread spins while waiting for the CPU1 kernel thread to free the simple lock.

Figure 7–1: Two Instances of the xx Module Asserting an Exclusive Lock

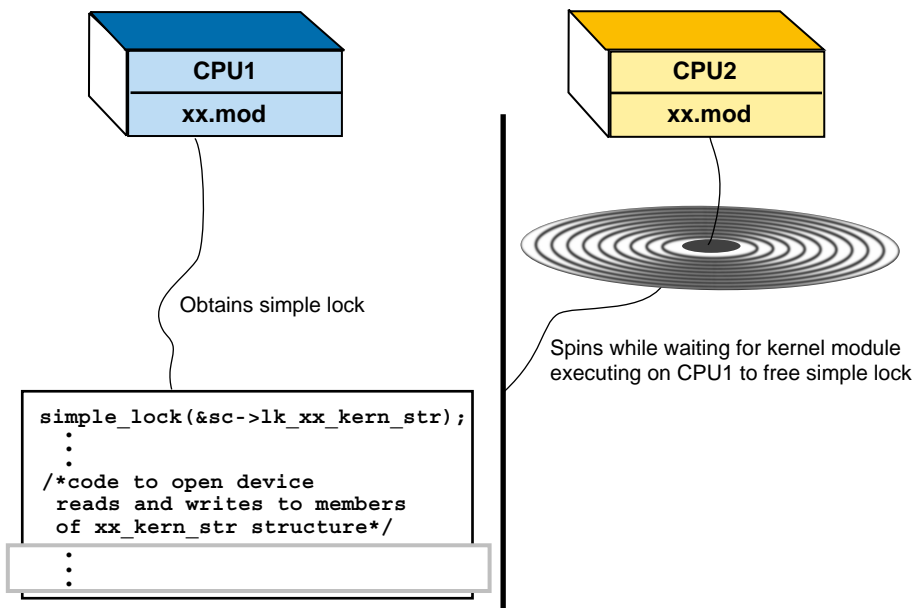

ZK-0962U-AI

7.4 Releasing a Previously Asserted Simple Lock

After asserting a simple lock (with exclusive access), you must release the lock by calling the `simple_unlock` routine. The following code fragment shows calls to `simple_unlock` by the xx kernel module's `xxopen` routine.

The `xxopen` routine is called as the result of an `open` system call.

The `xxopen` routine performs the following tasks:

- Checks to ensure that the open is unique
- Marks the device as open
- Returns the value 0 (zero) to the `open` system call to indicate success

The code fragment also shows the declaration of the simple lock structure in the `xx_kern_str` structure and the initialization of the simple lock structure by the kernel module's `xxattach` routine.

```

:
:
#include <kern/lock.h>
:
:
struct xx_kern_str {
    int sc_openf; /* Open flag */
    int sc_count; /* Count of characters written to device */
    simple_lock_data_t lk_xx_kern_str; /* SMP lock for xx_kern_str */
}xx_kern_str[NXX];
:
:
xxcattach(struct controller *ctlr)
{
    register struct xx_kern_str *sc = &xx_kern_str[ctlr->ctlr_num];

    /* Tasks to perform controller-specific initialization */
    :
    :
simple_lock_init(&sc->lk_xx_kern_str);
:
:
}
:
:
xxopen(dev, flag, format)
dev_t dev;
int flag;
int format;

register int unit = minor(dev);
struct controller *ctlr = xxinfo[unit];
struct xx_kern_str *sc = &xx_kern_str[unit];

if(unit >= NXX)
    return ENODEV; 1
simple_lock(&sc->lk_xx_kern_str); 2
if (sc->sc_openf == DN_OPEN) 3
{
    simple_unlock(&sc->lk_xx_kern_str);
    return (EBUSY);
}
if ((ctlr !=0) && (ctlr->alive & ALV_ALIVE)) 4
{
    sc->sc_openf = DN_OPEN;
    simple_unlock(&sc->lk_xx_kern_str);
    return(0);
}
else 5
{
    simple_unlock(&sc->lk_xx_kern_str);
    return(ENXIO);
}
}
:
:

```

- 1** If the number of device units on the system is greater than NXX, returns the error code ENODEV, which indicates that no such device exists on the system. This example test is used to ensure that a valid device exists.
- 2** Calls the simple_lock routine to assert an exclusive access on the following code block.

The `simple_lock` routine takes one argument: a pointer to a simple lock structure. You can declare this simple lock structure by using the `decl_simple_lock_data` routine. In this call, the `xxopen` routine passes the address of the `lk_xx_kern_str` field of the `xx_kern_str` structure pointer.

- 3 If the `sc_openf` field of the `sc` pointer is equal to `DN_OPEN`, calls the `simple_unlock` routine and returns the error code `EBUSY`, which indicates that the `NONE` device has already been opened. This example test is used to ensure that only one unit of the kernel module can be opened at a time. This type of open is referred to as an exclusive access open.

The `simple_unlock` routine releases a simple lock for the resource associated with the specified simple lock structure pointer. This simple lock was previously asserted by calling the `simple_lock` or `simple_lock_try` routine. In this call, the locked resource is referenced in the code block beginning with item 3.

The `simple_unlock` routine takes one argument: a pointer to a simple lock structure. You can declare this simple lock structure by using the `decl_simple_lock_data` routine. In this call, the `xxopen` routine passes the address of the `lk_xx_kern_str` field of the `xx_kern_str` structure pointer.

- 4 If the `ctlr` pointer is not equal to 0 (zero) and the `alive` field of `ctlr` has the `ALV_ALIVE` bit set, then the device exists. If this is the case, the `xxopen` routine sets the `sc_openf` field of the `sc` pointer to the open bit `DN_OPEN`, calls `simple_unlock` to free the lock, and returns the value 0 (zero) to indicate a successful open.
- 5 If the device does not exist, `xxopen` calls `simple_unlock` to free the lock and returns the error code `ENXIO`, which indicates that the device does not exist.

Figure 7–2 shows what happens when one instance of the `xx` kernel module releases a previously asserted exclusive lock on the code block that opens the device. In Figure 7–1, the CP1 kernel thread obtained the simple lock on the code block that opens the device. The CP2 kernel thread spun while waiting for the simple lock to be freed. After CPU 1 released the simple lock, CPU2 obtained the lock. In Figure 7–2, the CPU1 kernel thread makes another attempt to lock the code block that opens the device. This time it spins until the CPU2 kernel thread releases the simple lock.

Figure 7–2: One Instance of the xx Module Releasing an Exclusive Lock

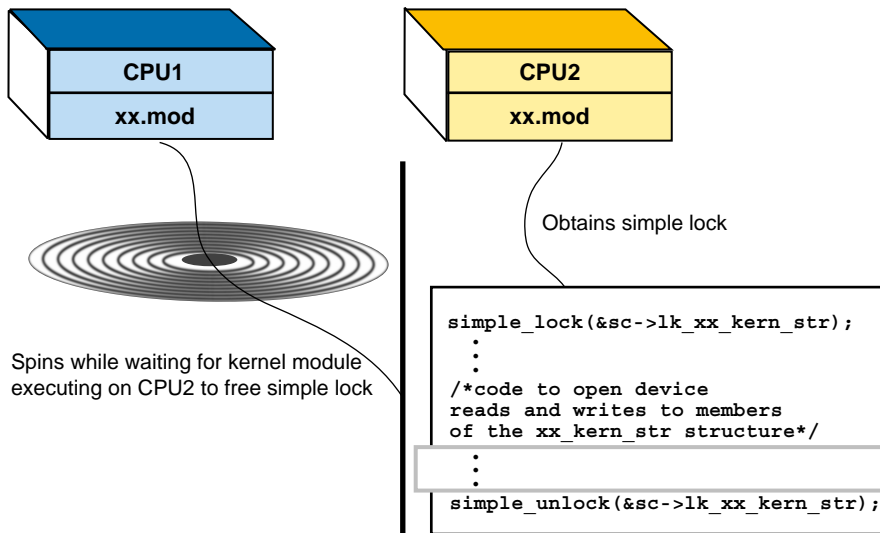

ZK-0963U-AI

7.5 Trying to Obtain a Simple Lock

In addition to explicitly asserting a simple lock, you can also try to assert the simple lock by calling the `simple_lock_try` routine. The main difference between `simple_lock` and `simple_lock_try` is that `simple_lock_try` returns immediately if the resource is already locked, while `simple_lock` spins until the lock has been obtained. Thus, call `simple_lock_try` when you need a simple lock but the code cannot spin until the lock is obtained.

The following code fragment shows a call to `simple_lock_try` by the `xx` kernel module's `xxopen` routine.

The `xxopen` routine is called as the result of an `open` system call.

The `xxopen` routine performs the following tasks:

- Checks to ensure that the open is unique
- Marks the device as open
- Returns the value 0 (zero) to the open system call to indicate success

The code fragment also shows the declaration of the simple lock structure in the `xx_kern_str` structure and the initialization of the simple lock structure by the kernel module's `xxcattach` routine.

```

:
:
#include <kern/lock.h>
:
:
struct xx_kern_str {
    int sc_openf; /* Open flag */
    int sc_count; /* Count of characters written to device */
    simple_lock_data_t lk_xx_kern_str; /* SMP lock for xx_kern_str */
}xx_kern_str[NXX];
:
:
xxcattach(struct controller *ctrl)
{
    register struct xx_kern_str *sc = &xx_kern_str[ctrl->ctrl_num];

    /* Tasks to perform controller-specific initialization */
    :
    :
simple_lock_init(&sc->lk_xx_kern_str);
:
:
}
:
:
xxopen(dev, flag, format)
    dev_t dev;
    int flag;
    int format;

    register int unit = minor(dev);
    struct controller *ctrl = xxinfo[unit];
    struct xx_kern_str *sc = &xx_kern_str[unit];
    boolean_t try_ret_val; 1

    if(unit >= NXX)
        return ENODEV; 2
    try_ret_val = simple_lock_try(&sc->lk_xx_kern_str); 3
    if (try_ret_val == TRUE) 4
    {
        if (sc->sc_openf == DN_OPEN)
        :
        :
    else
    /* Perform some other tasks if simple_lock_try fails *
    * to assert an exclusive access          */
    :
    :
}

```

1 Declares a variable to store the return value from the `simple_lock_try` routine.

The `simple_lock_try` routine returns one of the following values:

TRUE The `simple_lock_try` routine successfully asserted the simple lock.

FALSE The `simple_lock_try` routine failed to assert the simple lock.

- 2 If the number of device units on the system is greater than `NXX`, returns the error code `ENODEV`, which indicates that no such device exists on the system. This example test is used to ensure that a valid device exists.
- 3 Calls the `simple_lock_try` routine to try to assert an exclusive access on the following code block.

The `simple_lock_try` routine takes one argument: a pointer to a simple lock structure. You can declare this simple lock structure by using the `decl_simple_lock_data` routine. In this call, the `xxopen` routine passes the address of the `lk_xx_kern_str` field of the `xx_kern_str` structure pointer.

- 4 If the return from `simple_lock_try` is `TRUE`, checks the `sc_openf` field to determine if this is a unique open. Otherwise, if the return from `simple_lock_try` is `FALSE`, performs some other tasks.

Figure 7-3 shows what happens when two instances of the `xx` kernel module try to assert an exclusive lock on the code block that opens the device. As the figure shows, the CPU1 and CPU2 kernel threads try to assert an exclusive lock on the code block that opens the device. In this case, the CPU1 kernel thread successfully obtains the lock. To indicate this success, `simple_lock_try` returns the value `TRUE`. At the same time, the CPU2 kernel thread fails to obtain the lock and `simple_lock_try` immediately returns the value `FALSE` to indicate this.

Figure 7-3: The xx Module Trying to Assert an Exclusive Lock

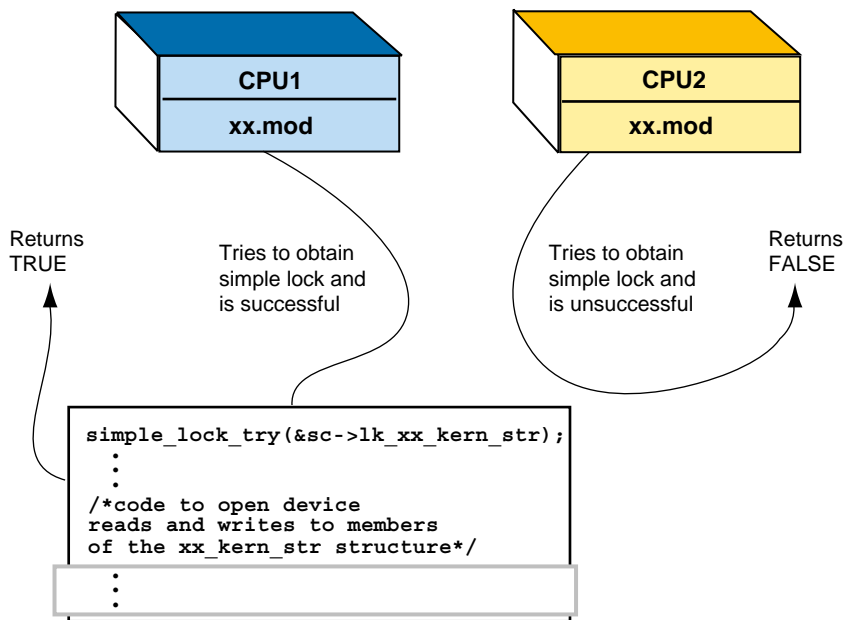

ZK-0964U-AI

7.6 Terminating a Simple Lock

After unlocking a simple lock (with exclusive access) and knowing that you are finished using the lock for this resource, you can terminate the lock by calling the `simple_lock_terminate` routine. Typically, you terminate any locks in the kernel module's controller (or device) `unattach` routine. These routines are associated with loadable modules (for example, drivers). One task associated with a controller or device `unattach` routine is to terminate any locks initialized in the kernel module's `unattach` routine.

The following code fragment shows a call to `simple_lock_terminate` by the `xx` kernel module's `xx_ctlr_unattach` routine. The code fragment also shows the declaration of the simple lock structure in the `xx_kern_str` structure, the initialization of the simple lock structure by the kernel module's `xxcattach` routine, and the unlocking of the simple lock structure by the module's `xxopen` routine.

```

:
#include <kern/lock.h> 1

```



```

:
:
struct xx_kern_str {
    int sc_openf; /* Open flag */
    int sc_count; /* Count of characters written to device */
    simple_lock_data_t lk_xx_kern_str; /* SMP lock for xx_kern_str */
}xx_kern_str[NXX]; 2
:
:
xxcattach(struct controller *ctrl)
{
    register struct xx_kern_str *sc = &xx_kern_str[ctrl->ctrl_num];

    /* Tasks to perform controller-specific initialization */
    :
    :
    simple_lock_init(&sc->lk_xx_kern_str); 3
    :
    :
}
:
:
xxopen(dev, flag, format)
    dev_t dev;
    int flag;
    int format;

    register int unit = minor(dev);
    struct controller *ctrl = xxinfo[unit];
    struct xx_kern_str *sc = &xx_kern_str[unit];

    if(unit >= NXX)
        return ENODEV; 4
    simple_lock(&sc->lk_xx_kern_str); 5
    if (sc->sc_openf == DN_OPEN) 6
    {
        simple_unlock(&sc->lk_xx_kern_str);
        return (EBUSY);
    }
    if ((ctrl !=0) && (ctrl->alive & ALV_ALIVE)) 7
    {
        sc->sc_openf = DN_OPEN;
        simple_unlock(&sc->lk_xx_kern_str);
        return(0);
    }
    else 8
    {
        simple_unlock(&sc->lk_xx_kern_str);
        return(ENXIO);
    }
}
:
:
xx_ctrl_unattach(bus, ctrl)
    struct bus *bus;
    struct controller *ctrl;
{
    register int unit = ctrl->ctrl_num;

    if ((unit > num_xx) || (unit < 0) {
        return(1);
    }

    if (xx_is_dynamic == 0) {
        return(1);
    }
}

```

```

}
/* Performs controller unattach tasks */
:
:
        simple_lock_terminate(&sc->lk_xx_kern_str); ⑨

```

- ① Includes the header file `/usr/sys/include/kern/lock.h`. The `lock.h` file defines the simple spin lock and complex lock structures that kernel modules use for synchronization on single-processor and multiprocessor systems.
- ② Declares an array of `kern_str` structures and calls it `xx_kern_str`. The `xx` kernel module declares a simple lock structure as a field of the `xx_kern_str` structure to protect the integrity of the data stored in the `sc_openf` and `sc_count` fields. A kernel module's `kern_str` structure is one resource that often requires protection in an SMP environment because kernel module routines use it to share data. It is possible that more than one kernel thread might need to access the fields of an `xx_kern_str` structure.
- ③ Calls the `simple_lock_init` routine to initialize the simple lock structure called `lk_xx_kern_str`.

The `simple_lock_init` routine takes one argument: a pointer to a simple lock structure. You can declare this simple lock structure by using the `decl_simple_lock_data` routine. In this call, the `xxattach` routine passes the address of the `lk_xx_kern_str` field of the `xx_kern_str` structure pointer. You need to initialize the simple lock structure only once. After initializing a simple lock structure, kernel modules can call `simple_lock` to assert exclusive access on the associated resource or `simple_lock_try` to attempt to assert exclusive access on the associated resource.

- ④ If the number of device units on the system is greater than `NXX`, returns the error code `ENODEV`, which indicates that no such device exists on the system. This example test is used to ensure that a valid device exists.
- ⑤ Calls the `simple_lock` routine to assert an exclusive access on the following code block.

The `simple_lock` routine takes one argument: a pointer to a simple lock structure. You can declare this simple lock structure by using the `decl_simple_lock_data` routine. In this call, the `xxopen` routine passes the address of the `lk_xx_kern_str` field of the `xx_kern_str` structure pointer.

- ⑥ If the `sc_openf` field of the `sc` pointer is equal to `DN_OPEN`, calls the `simple_unlock` routine and returns the error code `EBUSY`, which indicates that the `NONE` device has already been opened. This example test is used to ensure that only one unit of the module can be opened at a time. This type of open is referred to as an exclusive access open.

The `simple_unlock` routine releases a simple lock for the resource associated with the specified simple lock structure pointer. This simple lock was previously asserted by calling the `simple_lock` or `simple_lock_try` routine. In this call, the locked resource is referenced in the code block beginning with item 6.

The `simple_unlock` routine takes one argument: a pointer to a simple lock structure. You can declare this simple lock structure by using the `decl_simple_lock_data` routine. In this call, the `xxopen` routine passes the address of the `lk_xx_kern_str` field of the `xx_kern_str` structure pointer.

- 7 If the `ctlr` pointer is not equal to 0 (zero) and the `alive` field of `ctlr` has the `ALV_ALIVE` bit set, then the device exists. If this is the case, the `xxopen` routine sets the `sc_openf` field of the `sc` pointer to the open bit `DN_OPEN`, calls `simple_unlock` to free the lock, and returns the value 0 (zero) to indicate a successful open.
- 8 If the device does not exist, `xxopen` calls `simple_unlock` to free the lock and returns the error code `ENXIO`, which indicates that the device does not exist.
- 9 Calls the `simple_lock_terminate` routine to determine that the `xx` module is permanently done using this simple lock.

The `simple_lock_terminate` routine takes one argument: a pointer to a simple lock structure. You can declare this simple lock structure by using the `decl_simple_lock_data` routine. In this call, the `xx_ctlr_unattach` routine passes the address of the `lk_xx_kern_str` field of the `xx_kern_str` structure pointer. In calling `simple_lock_terminate`, the `xx` kernel module must not reference this simple lock again.

7.7 Using the `spl` Routines with Simple Locks

The `spl` routines block out asynchronous events on the CPU on which the `spl` call is performed. Simple locks block out other CPUs. You need to use both the `spl` routines and the simple lock routines when synchronizing with kernel threads and interrupt service routines. The following code fragment shows calls to the `spl` and simple lock routines:

```

:
:
#include <kern/lock.h> 1
:
:
struct tty_kern_str {
:
:
    decl_simple_lock_data( , lk_tty_kern_str); /* SMP lock for tty_kern_str */
:
:
}tty_kern_str[NSOMEDEVICE]; 2

```

```

:
:
simple_lock_init(&sc->lk_tty_kern_str);
:
:
s = spltty(); ③
simple_lock(&lk_tty_kern_str); ④
:
:
/* Manipulate resource */
:
:
simple_unlock(&lk_tty_kern_str); ⑤
splx(s); ⑥
:
:

```

- ① Includes the header file `/usr/sys/include/kern/lock.h`. The `lock.h` file defines the simple spin lock and complex lock structures that kernel modules use for synchronization on single-processor and multiprocessor systems.
- ② Declares an array of `kern_str` structures and calls it `lk_tty_kern_str`. This example module uses the `decl_simple_lock_data` routine to declare a simple lock structure as a field of the `tty_kern_str` structure.
- ③ Calls the `spltty` routine to mask out all tty (terminal device) interrupts.

The `spltty` routine takes no arguments.

The `spltty` routine returns an integer value that represents the CPU priority level that existed before the call. Note that the routine masks out all tty interrupts on the CPU on which it is called.

- ④ Calls the `simple_lock` routine to assert a lock with exclusive access for the resource associated with the `slock` structure pointer, which in this example is `lk_tty_kern_str`. Note that the routine ensures that no other kernel thread running on other CPUs can gain access to this resource. This contrasts with the `spl` routines, which block out kernel threads running on this CPU.
- ⑤ After manipulating the resource, calls `simple_unlock` to release the simple lock. This makes the resource available to kernel threads running on other CPUs.
- ⑥ Calls the `splx` routine to reset the CPU priority to the level specified by the value returned by `spltty`.

The `splx` routine takes one argument: a CPU priority level. This level must be a value returned by a previous call to one of the `spl` routines, in this example `spltty`. Calling `splx` releases the priority on this CPU.

Complex Lock Routines

After you decide that the complex lock method is the appropriate method for locking specific resources, you use the complex lock routines to accomplish the locking. To use complex locks in a kernel module, perform the following tasks:

- Declare a complex lock data structure
- Initialize a complex lock
- Perform access operations on a complex lock
- Terminate a complex lock

To illustrate the use of these routines, the chapter uses code from an example kernel module called `if_fta`, which operates on some FTA device.

8.1 Declaring a Complex Lock Data Structure

Before using a complex lock, declare a complex lock data structure for the resource you want to lock. The following code fragment shows how to declare a complex lock data structure for a specific field of the `fta_kern_str` structure:

```
#include <kern/lock.h> 1
.
struct cmd_buf {
    u_long *req_buf;
    u_long *rsp_buf;
    short timeout;
    struct cmd_buf *next;
}; 2
.
.
struct fta_kern_str {
.
    struct cmd_buf *q_first; /* first in the request queue */
    struct cmd_buf *q_last; /* last in the request queue */
    lock_data_t cmd_buf_q_lock; /* lock for the command */
                                /* request queue */
.
.
}; 3
.
.
```

1 Includes the header file `/usr/sys/include/kern/lock.h`. The `lock.h` file defines the simple spin lock and complex lock structures

that kernel modules use for synchronization on single-processor and multiprocessor systems.

- 2 Defines a `cmd_buf` data structure. The `fta_kern_str` structure declares two instances of `cmd_buf`. This structure describes a command queue and is a candidate for locking in a symmetric multiprocessing (SMP) environment. It is necessary to protect the integrity of the data stored in the command queue from multiple writes by more than one kernel thread.
- 3 Defines an `fta_kern_str` data structure. The example shows only those fields related to the discussion of complex locks.

In this example, the `fta_kern_str` structure contains the following fields:

- `q_first`
Specifies a pointer to a `cmd_buf` data structure. This field represents the first command queue in the linked list.
- `q_last`
Specifies a pointer to a `cmd_buf` data structure. This field represents the last command queue in the linked list.
- `cmd_buf_q_lock`
Declares a lock structure called `cmd_buf_q_lock`. The purpose of this lock is to protect the integrity of the data stored in the linked list of `cmd_buf` data structures. Note that the alternate name `lock_data_t` is used to declare the complex lock structure. Embedding the complex lock in the `fta_kern_str` structure protects the `cmd_buf` structure for any number of instances.

8.2 Initializing a Complex Lock

After declaring the complex lock data structure, you initialize it by calling the `lock_init` routine. The following code fragment shows a call to `lock_init` by the `if_fta` module's `ftaattach` routine. The `ftaattach` routine performs the tasks necessary to establish communication with the actual device. One of these tasks is to initialize any global data structures. Thus, the `ftaattach` routine initializes the complex lock data structure `cmd_buf_q_lock`.

The code fragment also shows the include file associated with complex locks, definitions of the `cmd_buf` and `fta_kern_str` structures, and the declaration of the complex lock.

```
⋮  
#include <kern/lock.h> 1: struct cmd_buf {
```

```

        u_long *req_buf;
        u_long *rsp_buf;
        short timeout;
        struct cmd_buf *next;
}; 2
:
:
struct fta_kern_str {
:
:
struct cmd_buf *q_first; /* first in the request queue */
struct cmd_buf *q_last; /* last in the request queue */
lock_data_t cmd_buf_q_lock; /* lock for the command */
                                /* request queue */
:
:
}; 3
:
:
ftaattach(struct controller *ctrlr)
{
    struct fta_kern_str *sc = &fta_kern_str[ctrlr->ctrlr_num];
:
:
    /* Tasks to perform controller-specific initialization */
:
:
lock_init(&sc->cmd_buf_q_lock, TRUE); 4
:
:
    /* Perform other tasks */
}

```

- 1** Includes the header file `/usr/sys/include/kern/lock.h`. The `lock.h` file defines the simple spin lock and complex lock structures that kernel modules use for synchronization on single-processor and multiprocessor systems.
- 2** Defines a `cmd_buf` data structure. The `fta_kern_str` structure declares two instances of `cmd_buf`. This structure describes a command queue and is a candidate for locking in an SMP environment. It is necessary to protect the integrity of the data stored in the command queue from multiple writes by more than one kernel thread.
- 3** Defines an `fta_kern_str` data structure. The example shows only those fields related to the discussion of complex locks.

In this example, the `fta_kern_str` structure contains the following fields:

- `q_first`
Specifies a pointer to a `cmd_buf` data structure. This field represents the first command queue in the linked list.
- `q_last`
Specifies a pointer to a `cmd_buf` data structure. This field represents the last command queue in the linked list.
- `cmd_buf_q_lock`

Declares a lock structure called `cmd_buf_q_lock`. The purpose of this lock is to protect the integrity of the data stored in the linked list of `cmd_buf` data structures. Note that the alternate name `lock_data_t` is used to declare the complex lock structure. Embedding the complex lock in the `fta_kern_str` structure protects the `cmd_buf` structure for any number of instances.

- 4] Calls the `lock_init` routine to initialize the simple lock structure called `cmd_buf_q_lock`.

The `lock_init` routine takes two arguments:

- The first argument specifies a pointer to the complex lock structure. In this call, the `ftaattach` routine passes the address of the `cmd_buf_q_lock` field of the `fta_kern_str` structure pointer. You need to initialize the complex lock structure only once.
- The second argument specifies a Boolean value that indicates whether to allow kernel threads to block (sleep) if the complex lock is asserted. You can pass to this argument only the value `TRUE` (allow kernel threads to block if the lock is asserted).

8.3 Performing Access Operations on a Complex Lock

After declaring and initializing the complex lock data structure, you can perform the following access operations on the complex lock:

- Assert a complex lock
- Release a previously asserted complex lock
- Try to assert a complex lock

Each of these tasks is discussed in the following sections.

8.3.1 Asserting a Complex Lock

After declaring and initializing the complex lock data structure, you can assert a complex lock with read-only access or a complex lock with write access by calling the `lock_read` or `lock_write` routine. The following sections describe how to use these routines.

8.3.1.1 Asserting a Complex Lock with Read-Only Access

The `lock_read` routine asserts a lock with read-only access for the resource associated with the specified `lock` structure pointer. The following code fragment shows a call to `lock_read` by the `if_fta` module's `ftaiocctl` routine.

The `ftaiocctl` routine is called as the result of an `ioctl` system call.

The `ftaiocctl` routine performs the following tasks:

- Determines the type of request
- Executes the request
- Returns data
- Returns the value 0 (zero) to the `ioctl` system call to indicate success

The code fragment also shows the include file associated with complex locks, definitions of the `cmd_buf` and `fta_kern_str` structures, the declaration of the complex lock structure in the `fta_kern_str` structure, and the initialization of the complex lock structure by the kernel module's `ftaattach` routine. Section 8.2 provides descriptions of these tasks.

```
#include <kern/lock.h>
:
:
struct cmd_buf {
    u_long *req_buf;
    u_long *rsp_buf;
    short timeout;
    struct cmd_buf *next;
};
:
:
struct fta_kern_str {
:
:
    struct cmd_buf *q_first; /* first in the request queue */
    struct cmd_buf *q_last; /* last in the request queue */
    lock_data_t cmd_buf_q_lock; /* lock for the command */
                                /* request queue */
:
:
};
:
:
ftaattach(struct controller *ctrl)
{
    struct fta_kern_str *sc = &fta_kern_str[ctrl->ctrl_num];
:
:
    /* Tasks to perform controller-specific initialization */
:
:
    lock_init(&sc->cmd_buf_q_lock, TRUE);
:
:
    /* Perform other tasks */
}
:
:
ftaiocctl(register struct ifnet *ifp,
           unsigned int cmd,
           caddr_t dataifp)
{
    struct fta_kern_str *sc = &fta_kern_str[ifp->if_unit];
:
:
    switch (cmd) {
        case SIOCENABLBACK: {
```

```

:
:
    if (ifp->if_flags & IFF_RUNNING) { ❶
        lock_read(&sc->cmd_buf_q_lock);
    }
/* Performs read operation on the resource */
    if(sc->q_first->req_buf = (u_long*)(data);
:
:
}

```

- ❶ Calls the `lock_read` routine if the `IFF_RUNNING` bit flag is set in the `if_flags` field of the `ifp` structure pointer.

The `lock_read` routine takes one argument: a pointer to the complex lock structure `lock`. This is the lock structure associated with the resource on which you want to assert a complex lock with read-only access. The `ftaiioctl` routine passes the address of the `cmd_buf_q_lock` field of the `fta_kern_str` structure pointer.

Figure 8–1 shows what happens when multiple instances of the `if_fta` kernel module assert a read-only complex lock on the specified code block. As the figure shows, kernel threads from the `if_fta` kernel module executing on CPU1, CPU2, and CPU3 assert read-only complex locks on the specified code block. The `lock_read` routine allows multiple kernel threads to have read-only access to the resource at the same time. When a read lock is asserted, the protected resource is guaranteed not to change. In this case, the `cmd_buf` resource is guaranteed not to change.

Figure 8–1: Three Instances of the if_fta Module Asserting a Read-Only Complex Lock

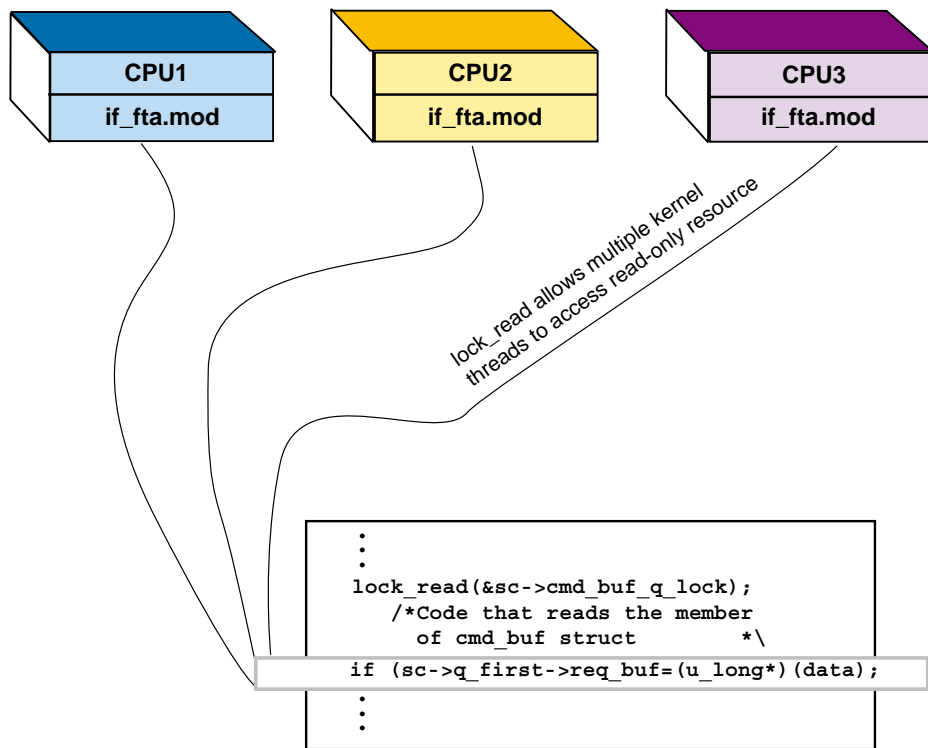

ZK-0961U-AI

8.3.1.2 Asserting a Complex Lock with Write Access

The `lock_write` routine asserts a lock with exclusive write access for the resource associated with the specified `lock` structure pointer. This means that once a write lock is asserted, no other kernel thread can gain read or write access to the resource until it is released.

The following code fragment shows a call to `lock_write` by the `if_fta` module's `ftaioc1` routine.

The `ftaioc1` routine is called as the result of an `ioctl` system call.

The `ftaioc1` routine performs the following tasks:

- Determines the type of request
- Executes the request

- Returns data
- Returns the value 0 (zero) to the `ioctl` system call to indicate success

The code fragment also shows the include file associated with complex locks, definitions of the `cmd_buf` and `fta_kern_str` structures, the declaration of the complex lock structure in the `fta_kern_str` structure, and the initialization of the complex lock structure by the kernel module's `ftaattach` routine. Section 8.2 provides descriptions of these tasks.

```
#include <kern/lock.h>
:
:
struct cmd_buf {
    u_long *req_buf;
    u_long *rsp_buf;
    short timeout;
    struct cmd_buf *next;
};
:
:
struct fta_kern_str {
:
    struct cmd_buf *q_first; /* first in the request queue */
    struct cmd_buf *q_last; /* last in the request queue */
    lock_data_t cmd_buf_q_lock; /* lock for the command */
                                /* request queue */
:
:
};
:
:
ftaattach(struct controller *ctrl)
{
    struct fta_kern_str *sc = &fta_kern_str[ctrl->ctrl_num];
:
:
    /* Tasks to perform controller-specific initialization */
:
:
    lock_init(&sc->cmd_buf_q_lock, TRUE);
:
:
    /* Perform other tasks */
}
:
:
ftaioctl(register struct ifnet *ifp,
          unsigned int cmd,
          caddr_t data)
{
    struct fta_kern_str *sc = &fta_kern_str[ifp->if_unit];
:
:
    switch (cmd) {
        case SIOCENABLBACK: {
:
:
            if (ifp->if_flags & IFF_RUNNING) { 1
                lock_write(&sc->cmd_buf_q_lock);
                sc->q_first->req_buf = (u_long*) (data);
            }
        }
    }
}
```

- 1 Calls the `lock_write` routine if the `IFF_RUNNING` bit flag is set in the `if_flags` field of the `ifp` structure pointer.

The `lock_write` routine takes one argument: a pointer to the complex lock structure `lock`. This is the lock structure associated with the resource on which you want to assert a complex lock with write access. The `ftaioctl` routine passes the address of the `cmd_buf_q_lock` field of the `fta_kern_str` structure pointer.

Figure 8–2 shows what happens when multiple instances of the `if_fta` kernel module assert a write complex lock on the specified code block. As the figure shows, kernel threads from the `if_fta` module executing on CPU1, CPU2, and CPU3 assert write complex locks on the specified code block. The kernel thread emanating from CPU3 asserts the write complex lock before the kernel threads emanating from CPU1 and CPU2. The kernel thread emanating from CPU3 writes to the `req_buf` field.

The `lock_write` routine blocks (puts to sleep) the kernel threads emanating from CPU1 and CPU2 by placing the requests on a lock queue. This shows that once `lock_write` successfully asserts a complex write lock, no other kernel thread can gain read or write access to the resource until the resource is released.

Figure 8–2: Three Instances of the if_fta Module Asserting a Write Complex Lock

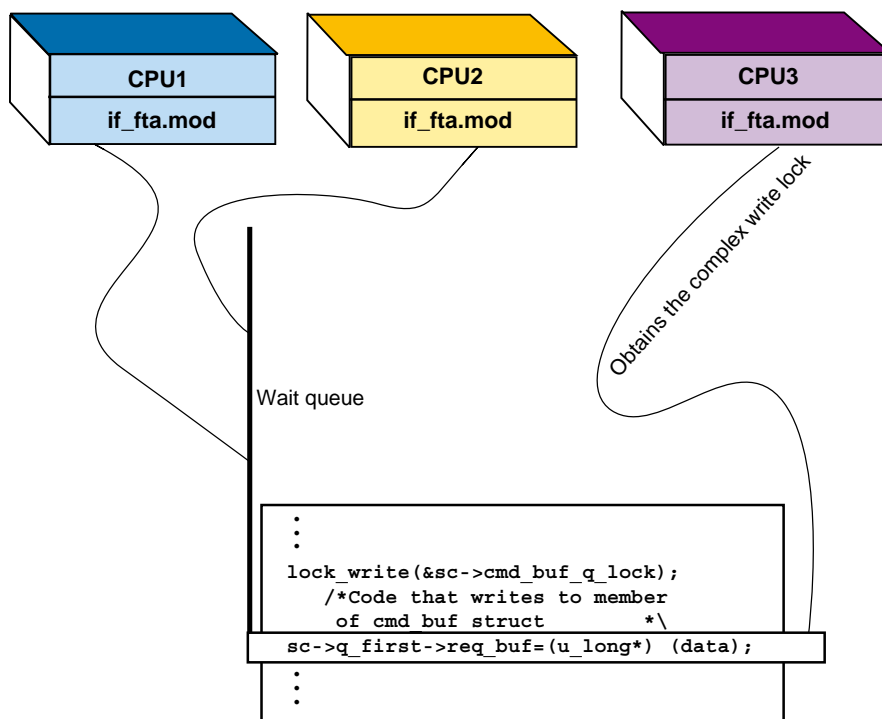

ZK-0960U-AI

8.3.2 Releasing a Previously Asserted Complex Lock

After you finish manipulating the resource associated with the complex lock, you need to release the lock. To release a complex lock that you previously asserted with a call to `lock_read` or `lock_write`, call the `lock_done` routine. The following code fragment shows a call to `lock_done` by the `if_fta` kernel module's `ftaioc1` routine.

The `ftaioc1` routine is called as the result of an `ioctl` system call.

The `ftaioc1` routine performs the following tasks:

- Determines the type of request
- Executes the request
- Returns data
- Returns the value 0 (zero) to the `ioctl` system call to indicate success

The code fragment also shows the include file associated with complex locks, definitions of the `cmd_buf` and `fta_kern_str` structures, the declaration of the complex lock structure in the `fta_kern_str` structure, the initialization of the complex lock structure by the module's `ftaattach` routine, and the assertion of a complex write lock on the code block by the kernel module's `ftaioctl` routine. Section 8.2 and Section 8.3.1.2 provide descriptions of these tasks.

```

:
:
#include <kern/lock.h>
:
:
struct cmd_buf {
    u_long *req_buf;
    u_long *rsp_buf;
    short timeout;
    struct cmd_buf *next;
};
:
:
struct fta_kern_str {
:
:
    struct cmd_buf *q_first; /* first in the request queue */
    struct cmd_buf *q_last; /* last in the request queue */
    lock_data_t cmd_buf_q_lock; /* lock for the command */
                                /* request queue */
:
:
};
:
:
ftaattach(struct controller *ctrl)
{
    struct fta_kern_str *sc = &fta_kern_str[ctrl->ctrl_num];
:
:
    /* Tasks to perform controller-specific initialization */
:
:
    lock_init(&sc->cmd_buf_q_lock, TRUE);
:
:
    /* Perform other tasks */
}
:
:
ftaioctl(register struct ifnet *ifp,
          unsigned int cmd,
          caddr_t data)
{
    struct fta_kern_str *sc = &fta_kern_str[ifp->if_unit];
:
:
    switch (cmd) {
        case SIOCENABLBACK: {
:
:
            if (ifp->if_flags & IFF_RUNNING) {
                lock_write(&sc->cmd_buf_q_lock);
                sc->q_first->req_buf = (u_long*) (data);

```

```
:\n\n    lock_done(&sc->cmd_buf_q_lock); 1\n\n}\n}
```

- 1 Calls the `lock_done` routine to release the complex write lock previously asserted by `lock_write`.

The `lock_done` routine takes one argument: a pointer to the complex lock structure `lock`. This is the lock structure associated with the resource on which you want to assert a complex lock with write access. The `ftaiocctl` routine passes the address of the `cmd_buf_q_lock` field of the `fta_kern_str` structure pointer.

Figure 8-3 shows what happens when one instance of the `if_fta` module releases a previously asserted complex write lock on the code block that writes to the command buffer queue. As the figure shows, the CPU3 kernel thread releases the complex write lock on the code block that writes to the command buffer queue. The CPU1 and CPU2 kernel threads are blocked, waiting on the wait queue for the complex write lock to be freed. Because the CPU1 kernel thread is first on the wait queue, it now obtains the complex write lock. Furthermore, the figure shows that the CPU3 kernel thread makes another attempt to assert a complex write lock on the code block. This time `lock_write` blocks (puts to sleep) the CPU3 kernel thread by placing it on the wait queue behind the CPU2 kernel thread.

Figure 8–3: One Instance of the if_fta Module Releasing a Complex Write Lock

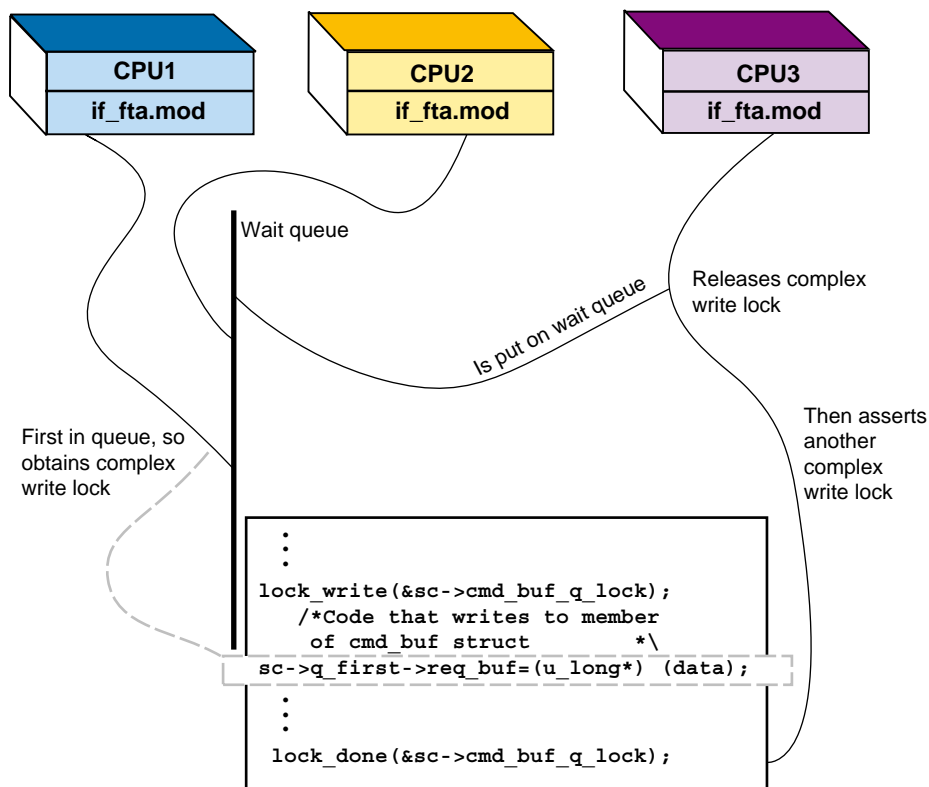

ZK-0975U-AI

8.3.3 Trying to Assert a Complex Lock

After declaring and initializing the complex lock data structure, you can try to assert a complex lock with read-only access or a complex lock with write access by calling the `lock_try_read` or `lock_try_write` routine. Unlike the `lock_read` or `lock_write` routines, the `lock_try_read` and `lock_try_write` routines do not block if the lock associated with the resource is owned by another kernel thread.

The following sections describe how to use these routines.

8.3.3.1 Trying to Assert a Complex Lock with Read-Only Access

To try to assert a complex lock with read-only access, call the `lock_try_read` routine. The `lock_try_read` routine tries to assert a complex lock (without blocking) with read-only access for the resource associated with the specified `lock` structure pointer.

The following code fragment shows a call to `lock_try_read` by the `if_fta` module's `ftaiioctl` routine. The code fragment also shows the include file associated with complex locks, definitions of the `cmd_buf` and `fta_kern_str` structures, the declaration of the complex lock structure in the `fta_kern_str` structure, and the initialization of the complex lock structure by the module's `ftaattach` routine. Section 8.2 provides descriptions of these tasks. In addition, the code fragment shows a call to `lock_done` if the complex read-only lock is successfully asserted.

```

:
:
#include <kern/lock.h>
:
:
struct cmd_buf {
    u_long *req_buf;
    u_long *rsp_buf;
    short timeout;
    struct cmd_buf *next;
};
:
:
struct fta_kern_str {
:
:
struct cmd_buf *q_first; /* first in the request queue */
struct cmd_buf *q_last; /* last in the request queue */
lock_data_t cmd_buf_q_lock; /* lock for the command */
/* request queue */
:
:
};
:
:
ftaattach(struct controller *ctrl)
{
    struct fta_kern_str *sc = &fta_kern_str[ctrl->ctrl_num];
:
:
    /* Tasks to perform controller-specific initialization */
:
:
lock_init(&sc->cmd_buf_q_lock, TRUE);
:
:
    /* Perform other tasks */
}
:
:
ftaiioctl(register struct ifnet *ifp,
           unsigned int cmd,
           caddr_t data)
{
    struct fta_kern_str *sc = &fta_kern_str[ifp->if_unit];

```

```

boolean_t try_ret_val; 1
:
:
switch (cmd) {
  case SIOCENABLBACK: {
:
:
    if (ifp->if_flags & IFF_RUNNING) { 2
      try_ret_val = lock_try_read(&sc->cmd_buf_q_lock);
      if (try_ret_val == TRUE) { 3
        if (sc->q_first->req_buf == (u_long*) (data)) {
:
:
          lock_done(&sc->cmd_buf_q_lock); 4
        }
      }
    }
:
:
    else 5
:
:
      /* Code that executes when try_ret_val == FALSE */
:
:
    }
:
:
  }
:
:
}

```

1 Declares a variable to store one of the following return values from the `lock_try_read` routine:

TRUE	The attempt to acquire the read-only complex lock was successful.
FALSE	The attempt to acquire the read-only complex lock was unsuccessful.

2 Calls the `lock_try_read` routine if the `IFF_RUNNING` bit flag is set in the `if_flags` field of the `ifp` structure pointer.

The `lock_try_read` routine takes one argument: a pointer to the complex lock structure `lock`. This is the lock structure associated with the resource on which you want to try to assert a complex lock with read-only access. The `ftaiioctl` routine passes the address of the `cmd_buf_q_lock` field of the `fta_kern_str` structure pointer.

3 If the return from `lock_try_read` is `TRUE`, obtains the read-only complex lock on the code block that performs the read operation.

4 After completing the read operation, releases the read-only complex lock by calling `lock_done`.

- 5 If the return from `lock_try_read` is `FALSE`, did not obtain the read-only complex lock on the code block that performs the read operation. In this case, it is not necessary to call `lock_done`.

Figure 8–4 shows what happens when two instances of the `if_fta` module attempt to assert a read-only complex lock on the code block that performs a read operation on the resource. As the figure shows, both the CPU1 and CPU2 kernel threads try to assert a read-only complex lock on the code block that performs a read operation on the command buffer queue. Because this is a read-only operation, the CPU1 and CPU2 kernel threads obtain the read-only complex lock, and as a result, `lock_try_read` returns the value `TRUE` in both cases.

Figure 8–4: The `if_fta` Module Trying to Assert a Complex Read-Only Lock

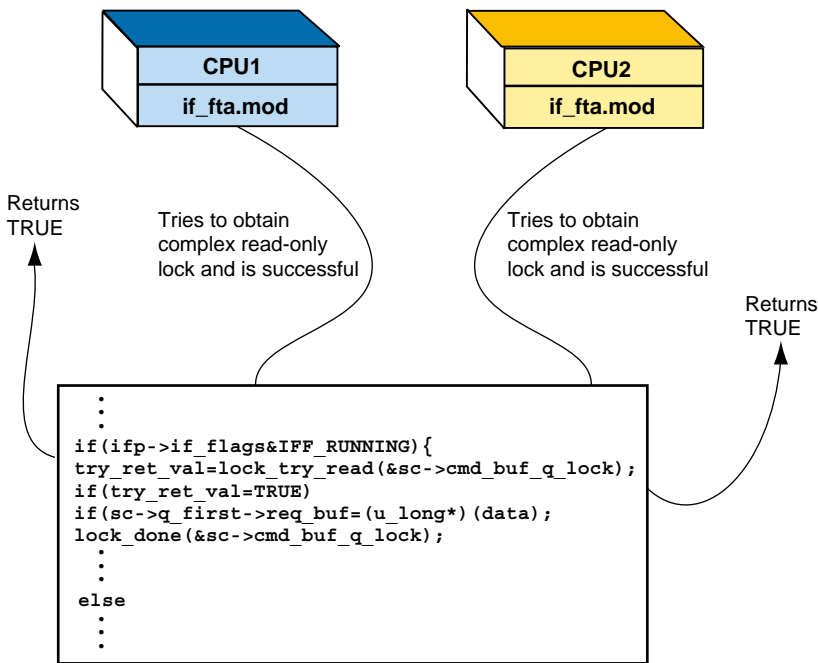

ZK-0976U-AI

8.3.3.2 Trying to Assert a Complex Lock with Write Access

To try to assert a complex lock with write access, call the `lock_try_write` routine. The `lock_try_write` routine tries to assert a complex lock (without blocking) with write access for the resource associated with the specified lock structure pointer.

The following code fragment shows a call to `lock_try_write` by the `if_fta` module's `ftaiioctl` routine. The code fragment also shows the include file associated with complex locks, definitions of the `cmd_buf` and `fta_kern_str` structures, the declaration of the complex lock structure in the `fta_kern_str` structure, and the initialization of the complex lock structure by the module's `ftaattach` routine. Section 8.2 provides descriptions of these tasks. In addition, the code fragment shows a call to `lock_done` if the complex write lock is successfully asserted.

```

:
:
#include <kern/lock.h>
:
:
struct cmd_buf {
    u_long *req_buf;
    u_long *rsp_buf;
    short timeout;
    struct cmd_buf *next;
};
:
:
:
struct fta_kern_str {
:
:
:
struct cmd_buf *q_first; /* first in the request queue */
struct cmd_buf *q_last; /* last in the request queue */
lock_data_t cmd_buf_q_lock; /* lock for the command */
/* request queue */
:
:
};
:
:
:
ftaattach(struct controller *ctrl)
{
    struct fta_kern_str *sc = &fta_kern_str[ctrl->ctrl_num];
:
:
    /* Tasks to perform controller-specific initialization */
:
:
lock_init(&sc->cmd_buf_q_lock, TRUE);
:
:
    /* Perform other tasks */
}
:
:
ftaiioctl(register struct ifnet *ifp,
           unsigned int cmd,
           caddr_t data)
{
    struct fta_kern_str *sc = &fta_kern_str[ifp->if_unit];
    boolean_t try_ret_val; 1
:
:
    switch (cmd) {
        case SIOCENABLBACK: {
:
:
            if (ifp->if_flags & IFF_RUNNING) { 2
                try_ret_val = lock_try_write(&sc->cmd_buf_q_lock);

```

```

    if (try_ret_val == TRUE) { 3
        sc->q_first->req_buf = (u_long*) (data);
        :
        :
        lock_done(&sc->cmd_buf_q_lock); 4
    }
    :
    :
    else 5
        :
        :
        /* Code that executes when try_ret_val == FALSE */
        :
        :
    }
    :
    :
}

```

1 Declares a variable to store one of the following return values from the `lock_try_write` routine:

TRUE	The attempt to acquire the write complex lock was successful.
FALSE	The attempt to acquire the write complex lock was unsuccessful.

2 Calls the `lock_try_write` routine if the `IFF_RUNNING` bit flag is set in the `if_flags` field of the `ifp` structure pointer.

The `lock_try_write` routine takes one argument: a pointer to the complex lock structure `lock`. This is the lock structure associated with the resource on which you want to try to assert write access. The `ftaiocctl` routine passes the address of the `cmd_buf_q_lock` field of the `fta_kern_str` structure pointer.

3 If the return from `lock_try_write` is `TRUE`, obtains the write complex lock on the code block that performs the write operation.

4 After completing the write operation, releases the write complex lock by calling `lock_done`.

5 If the return from `lock_try_write` is `FALSE`, did not obtain the write complex lock on the code block that performs the write operation. In this case, it is not necessary to call `lock_done`.

Figure 8-5 shows what happens when two instances of the `if_fta` module attempt to assert a write complex lock on the code block that performs a write operation on the resource. As the figure shows, both the CPU1 and CPU2 kernel threads try to assert a write complex lock on the code block that performs a write operation on the command

buffer queue. The CPU1 kernel thread obtains the write complex lock first and as a result `lock_try_write` returns the value `TRUE`. Because the CPU2 kernel thread was not successful in obtaining the write complex lock, `lock_try_write` immediately returns (does not block the kernel thread) the value `FALSE`.

Figure 8–5: The `if_fta` Module Trying to Assert a Complex Write Lock

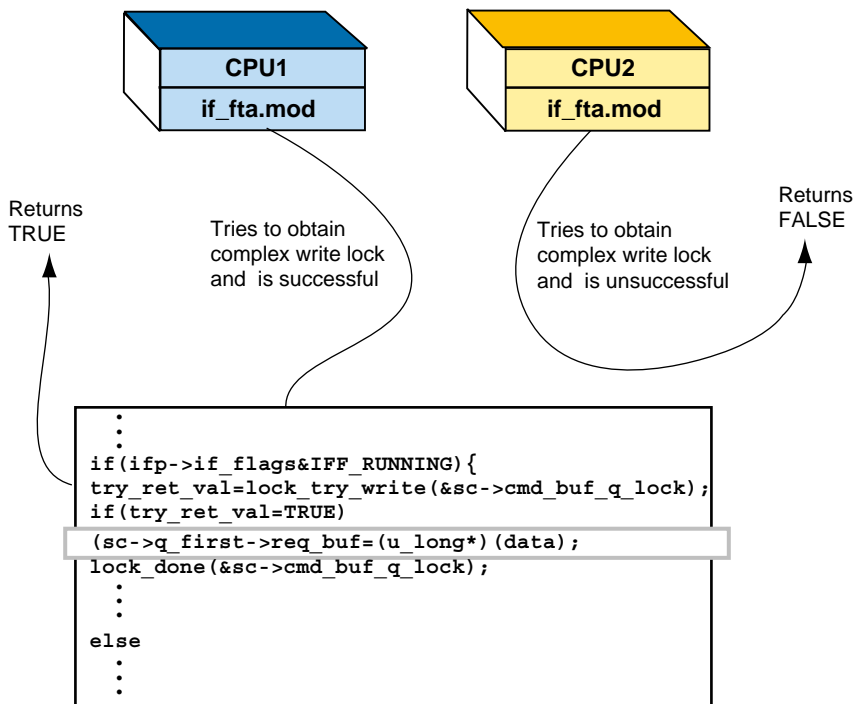

ZK-0977U-AI

8.4 Terminating a Complex Lock

After unlocking a complex read or write lock and knowing that you are finished using the lock for this resource, you can terminate the lock by calling the `lock_terminate` routine. Typically, you terminate any locks in the kernel module's controller (or device) `unattach` routine. These routines are associated with loadable kernel modules. One task associated with a controller or device `unattach` routine is to terminate any locks initialized in the kernel module's `attach` routine.

The following code fragment shows a call to `lock_terminate` by the `if_fta` module's `fta_ctlr_unattach` routine. The code fragment also shows the include file associated with complex locks, definitions of the

cmd_buf and fta_kern_str structures, the declaration of the complex lock structure in the fta_kern_str structure, and the initialization of the complex lock structure by the kernel module's ftaattach routine. Section 8.2 provides descriptions of these tasks. In addition, the code fragment shows calls to lock_write and lock_done.

```

:
:
#include <kern/lock.h>
:
:
struct cmd_buf {
    u_long *req_buf;
    u_long *rsp_buf;
    short timeout;
    struct cmd_buf *next;
};
:
:
struct fta_kern_str {
:
:
struct cmd_buf *q_first; /* first in the request queue */
struct cmd_buf *q_last; /* last in the request queue */
lock_data_t cmd_buf_q_lock; /* lock for the command */
                                /* request queue */
:
:
};
:
:
ftaattach(struct controller *ctrl)
{
    struct fta_kern_str *sc = &fta_kern_str[ctrl->ctrl_num];
:
:
    /* Tasks to perform controller-specific initialization */
:
:
lock_init(&sc->cmd_buf_q_lock, TRUE);
:
:
    /* Perform other tasks */
}
:
:
ftaioctl(register struct ifnet *ifp,
          unsigned int cmd,
          caddr_t data)
{
    struct fta_kern_str *sc = &fta_kern_str[ifp->if_unit];
:
:
    switch (cmd) {
        case SIOCENABLBACK: {
:
:
            if (ifp->if_flags & IFF_RUNNING) {
                lock_write(&sc->cmd_buf_q_lock);
                sc->q_first->req_buf = (u_long*) (data);
:
:
                lock_done(&sc->cmd_buf_q_lock);

```



```

:
:
}
:
:
fta_ctrl_unattach(struct bus *bus,
                  struct controller *ctrl)
{
    register int unit = ctrl->ctrl_num;

    if ((unit > num_fta) || (unit < 0) {
        return(1);
    }

    if (fta_is_dynamic == 0) {
        return(1);
    }
}
/* Performs controller unattach tasks */
:
:
    lock_terminate(&sc->cmd_buf_q_lock); 1
:
:
}

```

- 1** Calls the `lock_terminate` routine to determine that the `if_fta` module is permanently done using this complex lock.

The `lock_terminate` routine takes one argument: a pointer to the complex lock structure `lock`. In this call, the `fta_ctrl_unattach` routine passes the address of the `cmd_buf_q_lock` field of the `fta_kern_str` structure pointer. In calling `lock_terminate`, the `if_fta` module must not reference this complex lock again.

Kernel Threads

This chapter discusses the following topics associated with kernel threads:

- The advantages of using kernel threads
- Kernel threads execution
- Issues related to using kernel threads
- Kernel threads operations
- The `thread` and `task` data structures

In addition, this chapter discusses the routines that allow you to perform kernel thread operations. Specifically, these routines allow you to:

- Create and start a kernel thread
- Block (put to sleep) a kernel thread
- Unblock (wake up) kernel threads
- Terminate a kernel thread
- Set a timer for the current kernel thread
- Obtain the current kernel thread

9.1 Using Kernel Threads in Kernel Modules

A thread is a single, sequential flow of control within a program. Within a single thread is a single point of execution. Applications use threads to improve their performance (throughput, computational speed, and responsiveness). To start, terminate, delete, and perform other operations on threads, the application programmer calls the routines that the DECthreads product provides.

The term *kernel thread* distinguishes between the threads that applications use. A kernel thread is a single sequential flow of control within a kernel module or other systems-based program. The kernel module or other systems-based program uses the routines (instead of a threads library package such as DECthreads) to start, terminate, delete, and perform other kernel thread operations.

Kernel threads execute within (and share) a single address space. Therefore, kernel threads read from and write to the same memory locations.

You use kernel threads to improve the performance of a kernel module. Multiple kernel threads are useful in a multiprocessor environment, where kernel threads run concurrently on separate CPUs. However, multiple kernel threads also improve kernel module performance on single-processor systems by permitting the overlap of input, output, or other slow operations with computational operations.

Kernel threads allow kernel modules to perform other useful work while waiting for a device to produce its next event, such as the completion of a disk transfer or the receipt of a packet from the network.

Typically, you use kernel threads in kernel modules when:

- The kernel module must perform a long operation
One example of a long operation is the reset sequences associated with a multistep device.
One reason for creating a kernel thread to perform a long operation is to prevent the kernel module from running at a high interrupt priority level (IPL) for long periods of time.
- The resource or resources associated with that operation are not available
This situation refers to allocating memory or accessing address space that might cause a page fault.
- The operation performed on the resource (for example, blocking) is illegal.
One example of this operation is that access to a data item is not allowed at an elevated IPL, for example, the `proc` structure.

Figure 9–1 shows one example of the previously described situations. As the figure shows, a kernel module must check a number of device state changes. One of these device state changes checks for an adapter fatal error condition. If the fatal error condition occurs, the kernel module must reset the adapter. The code that resets the adapter must block to accomplish the adapter reset operation. Furthermore, the only time this error can occur is during a device interrupt. It is not legal to block in an interrupt service routine. Therefore, the figure shows that the interrupt service routine for the kernel module calls an `xxstate` routine that handles all of the state changes. This routine creates a kernel thread called `xxerr` that starts up when the adapter becomes operational. The job of this kernel thread is to reset the adapter when a fatal error occurs. Note that it is legal for this kernel thread to perform blocking operations.

Figure 9–1: Using Kernel Threads in a Kernel Module

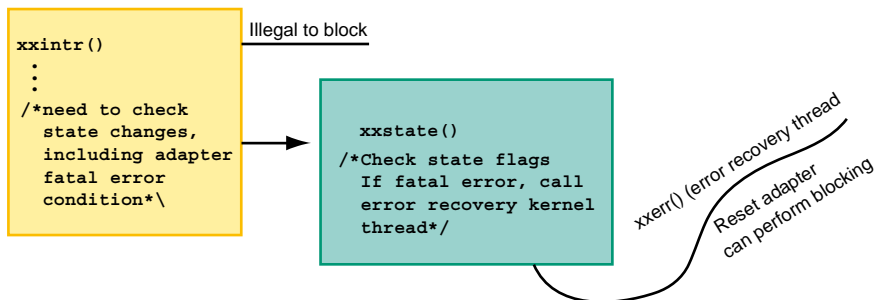

ZK-1015U-AI

9.1.1 Kernel Threads Execution

You can view multiple kernel threads in a program as executing simultaneously. However, you cannot make any assumptions about the relative start or finish times of kernel threads or the sequence in which they execute. You can influence the scheduling of kernel threads by setting scheduling and policy priority.

Each kernel thread has its own unique thread identifier. This thread identifier is a pointer to the `thread` data structure associated with the kernel thread. The kernel threads creation routines return this `thread` data structure pointer to the kernel module after they successfully create and start the kernel thread. Kernel modules use this pointer as a handle to a specific kernel thread in calls to other kernel thread routines.

A kernel thread changes states during the course of its execution and is always in one of the following states:

- **Waiting**
The kernel thread is not eligible to execute because it is synchronizing with another kernel thread or with an external event, such as I/O.
- **Ready**
The kernel thread is eligible to be executed by a CPU.
- **Running**
The kernel thread is currently being executed by a CPU.
- **Terminated**
The kernel thread has completed all of its work.

9.1.2 Issues Related to Using Kernel Threads

When you design and code a kernel module that uses the kernel thread routines, consider the following issues:

- Interplay among kernel threads

Using kernel threads can simplify the coding and designing of a kernel module. However, you need to be sure that the synchronization and interplay among kernel threads is correct. You use simple and complex locks to synchronize access to data.

- Race conditions

A race condition is a programming error that causes unpredictable and erroneous program behavior. Specifically, the error occurs when two or more kernel threads perform an operation and the result of the operation depends on unpredictable timing factors, for example, when each kernel thread executes and waits and when each kernel thread completes the operation.

- Deadlocks

A deadlock is a programming error that causes two or more kernel threads to be blocked indefinitely. Specifically, the error occurs when a kernel thread holds a resource while waiting for a resource held by another kernel thread and that kernel thread is also waiting for the first kernel thread's resource.

- Priority inversion

Priority inversion occurs when the interaction among three or more kernel threads blocks the highest-priority kernel thread from executing. For example, a high-priority kernel thread waits for a resource locked by a low-priority kernel thread, and the low-priority kernel thread waits while a middle-priority kernel thread executes. The high-priority kernel thread is made to wait while a kernel thread of lower priority (the middle-priority kernel thread) executes.

To avoid priority inversion, associate a priority with each resource that is at least as high as the highest-priority kernel thread that will use it, and force any kernel thread using that object to first raise its priority to that associated with the object.

9.1.3 Kernel Threads Operations

Table 9–1 lists the routines associated with kernel threads and describes the operations they perform.

Table 9–1: Summary of Operations That Kernel Thread Routines Perform

Routines	Description
<i>Creating kernel threads</i>	
<code>kernel_isrthread</code>	Starts a fixed-priority kernel thread dedicated to interrupt service.
<code>kernel_thread_w_arg</code>	Starts a kernel thread with a calling argument passed in.
<i>Blocking kernel threads</i>	
<code>assert_wait_mesg</code>	Asserts that the current kernel thread is about to block (sleep).
<code>thread_block</code>	Blocks (puts to sleep) the current kernel thread.
<i>Unblocking kernel threads</i>	
<code>thread_wakeup</code>	Wakes up all kernel threads waiting for the specified event.
<code>thread_wakeup_one</code>	Wakes up the first kernel thread waiting on a channel.
<i>Terminating kernel threads</i>	
<code>thread_terminate</code>	Prepares to stop or stops execution of the specified kernel thread.
<code>thread_halt_self</code>	Handles asynchronous traps for self-terminating kernel threads.
<i>Miscellaneous</i>	
<code>current_task</code>	Returns a pointer to the task structure associated with the currently running kernel thread.
<code>thread_set_timeout</code>	Sets a timer for the current kernel thread.

9.2 Using the thread and task Data Structures

This section discusses the two data structures that kernel thread routines use: `thread` and `task`. The `thread` data structure contains kernel thread information. Kernel modules typically use the `wait_result` field (along with the `current_thread` routine) to check for the result of the wait. The header file `/usr/sys/include/kern/thread.h` shows a typedef statement that assigns the alternate name `thread_t` for a pointer to the `thread` structure. Many of the kernel thread routines operate on these pointers to `thread` structures.

The `thread` structure is an opaque data structure; that is, all of its associated fields (except for the `wait_result` field) are referenced and manipulated by the operating system and not by the user of kernel threads.

The `task` data structure contains task-related information. The header file `/usr/sys/include/kern/task.h` shows a `typedef` statement that assigns the alternate name `task_t` for a pointer to the `task` structure. Some of the kernel thread routines require that you pass a pointer to the `task` structure.

The `task` structure is an opaque data structure; that is, all of its associated fields are referenced and manipulated by the operating system and not by the user of kernel threads.

9.3 Creating and Starting a Kernel Thread

You can create and start a kernel thread with the following routines:

- `kernel_thread_w_arg`
Starts a kernel thread with a calling argument passed in.
- `kernel_isrthread`
Starts a fixed-priority kernel thread dedicated to interrupt service.

The following sections describe each of these routines.

9.3.1 Creating and Starting a Kernel Thread at a Specified Entry Point

To create and start a kernel thread at a specified entry point and with a specified argument, call the `kernel_thread_w_arg` routine. The `kernel_thread_w_arg` routine creates and starts a kernel thread in the specified task at the specified entry point with a specified argument. The `kernel_thread_w_arg` routine passes the specified argument to the newly created kernel thread. The `kernel_thread_w_arg` routine creates and starts a kernel thread with timeshare scheduling. A kernel thread created with timeshare scheduling means that its priority degrades if it consumes an inordinate amount of CPU resources. A kernel module should call `kernel_thread_w_arg` only for long-running tasks. A kernel module should always attach a kernel thread to the first task.

The `kernel_thread_w_arg` routine is actually a convenience wrapper for the `thread_create` routine (which creates the kernel thread) and the `thread_start` routine (which starts the newly created kernel thread).

The following code fragment shows a call to `kernel_thread_w_arg` by the `if_fta` module's `fta_transition_state` routine. The `fta_transition_state` routine changes the state of the kernel module by performing certain fixed functions for any given state.

```
#include <kern/thread.h> 1
:
:
#define ADAP "fta"
:
:
extern task_t first_task; 2
:
:
struct fta_kern_str {
:
:
short reinit_thread_started; /* reinit thread running? */
:
:
}; 3
:
:
struct ifnet {
:
:
short if_unit; /* subunit for lower-level driver */
:
:
};
:
:
fta_transition_state(struct fta_kern_str *sc,
                    short unit,
                    short state)
{
:
:
:
switch(state) {
:
:
:
case PI_OPERATIONAL: {
int s;
NODATA_CMD *req_buff;
thread_t thread; 4

if (sc->reinit_thread_started == FALSE) { 5

thread = kernel_thread_w_arg(first_task,
                            fta_error_recovery,
                            (void *)sc); 6

if (thread == NULL) { 7
printf("%s%d: Cannot start error recovery thread.\n",
      ADAP, ifp->if_unit);
}
sc->reinit_thread_started = TRUE;
}
}
}
```

1 Includes the header file `/usr/sys/include/kern/thread.h`. The `thread.h` file defines structures that kernel thread routines use.

- 2 Declares a pointer to a task structure and calls it `first_task`. Every kernel thread must be part of a task. You pass this pointer to the `kernel_thread_w_arg` routine.
- 3 Defines an `fta_kern_str` data structure. The example shows only the field related to the discussion of the `kernel_thread_w_arg` routine.
- 4 Declares a pointer to a thread structure and calls it `thread`. This variable stores the thread structure pointer returned by `kernel_thread_w_arg`.
- 5 If the reinitialized kernel thread evaluates to `FALSE` (the reinit kernel thread is not running), calls the `kernel_thread_w_arg` routine.
- 6 Calls the `kernel_thread_w_arg` routine.

The `kernel_thread_w_arg` routine takes three arguments:

- The first argument specifies a pointer to a task structure. This pointer identifies the task in which the `kernel_thread_w_arg` routine starts the newly created kernel thread. In this call, the `fta_transition_state` routine passes a task structure called `first_task`.
 - The second argument specifies a pointer to a routine that is the entry point for the newly created kernel thread. In this call, the entry point for the newly created kernel thread is the `fta_error_recovery` routine. The `fta_error_recovery` routine is a kernel thread that starts up when the adapter becomes operational. This kernel thread is responsible for resetting the adapter in the event of a fatal error.
 - The third argument specifies an argument that `kernel_thread_w_arg` passes to the entry point specified in the second argument. In this call, the `fta_transition_state` routine passes a pointer to the `fta_kern_str` structure. The `fta_error_recovery` routine performs a variety of tasks that require the `fta_kern_str` structure.
- 7 Upon successful completion, `kernel_thread_w_arg` returns a pointer to the thread structure associated with the kernel thread started at the specified entry point. Kernel modules can use this pointer as a handle to a specific kernel thread in calls to other kernel thread routines.

The `fta_transition_state` routine checks the return. If the return is `NULL`, `kernel_thread_w_arg` did not create the error recovery kernel thread. The `fta_transition_state` routine calls `printf` to display an appropriate message on the console terminal. If the return is not `NULL`, `fta_transition_state` sets the

`reinit_thread_started` field to the value `TRUE` to indicate that the error recovery kernel thread is started.

9.3.2 Creating and Starting a Fixed-Priority Kernel Thread Dedicated to Interrupt Service

To create and start a fixed-priority kernel thread dedicated to interrupt service, call the `kernel_isrthread` routine. The `kernel_isrthread` routine creates and starts a kernel thread at the specified entry point. This kernel thread handles only interrupt service requests in the specified task and at the specified priority level. A kernel module should always attach a kernel thread to the first task.

The following code fragment shows a call to `kernel_isrthread` by the `if_fta` module's `ftaprobe` routine. The `ftaprobe` routine determines if the adapter exists, fills in a variety of register values, and initializes a variety of descriptors.

```
:\n:\n#include <kern/thread.h> ❶\n:\n:\nextern task_t first_task; ❷\n:\n:\nftaprobe(io_handle_t reg,\n         struct controller *ctlr)\n{\n:\n:\n\n    thread = kernel_isrthread(first_task,\n                              fta_rec_intr,\n                              BASEPRI_SYSTEM); ❸\n:\n:\n}
```

- ❶ Includes the header file `/usr/sys/include/kern/thread.h`. The `thread.h` file defines structures that kernel thread routines use.
- ❷ Declares a pointer to a task structure and calls it `first_task`. Every kernel thread must be part of a task. You pass this pointer to the `kernel_isrthread` routine.
- ❸ Calls the `kernel_isrthread` routine.

The `kernel_isrthread` routine takes three arguments:

- The first argument specifies a pointer to a task structure. This pointer identifies the task in which the `kernel_isrthread` routine starts the newly created kernel thread dedicated to interrupt service handling. In this call, the `ftaprobe` routine passes a task structure called `first_task`.

- The second argument specifies a pointer to a routine that is the entry point for the newly created kernel thread. In this call, the entry point for the newly created kernel thread is the `fta_rec_intr` routine. The `fta_rec_intr` routine is a kernel thread that starts up when the kernel module discovers a receive type device interrupt. This kernel thread is responsible for handling the receive type interrupt.
- The third argument specifies the scheduling priority level for the newly created kernel thread.

The following priority usage table describes the possible scheduling priorities. The first column shows a range of priorities. The second column shows an associated scheduling priority constant defined in `<src/kernel/kern/sched.h>` (if applicable). The third column describes the usage of the priority ranges. To specify a scheduling priority of 38, you pass the constant `BASEPRI_SYSTEM`, as shown in the example. To specify a scheduling priority of 33, you can pass the following: `BASEPRI_HIGHEST + 1`.

Priority	Constant	Usage
0—31	N/A	Realtime kernel threads
32—38	<code>BASEPRI_HIGHEST — BASEPRI_SYSTEM</code>	Operating system kernel threads
44—64	<code>BASEPRI_USER — BASEPRI_LOWEST</code>	User kernel threads

9.4 Blocking (Putting to Sleep) a Kernel Thread

The routines you use to block (put to sleep) a kernel thread depend on whether or not the block (sleep) can be interrupted. For interruptable sleep (that is, the kernel thread can take asynchronous signals), you must call the symmetric multiprocessor (SMP) sleep call, `mpsleep` (see Section 9.4.2).

For uninterruptable sleep, use one of the following routines:

- `assert_wait_mesg`

Call this routine to assert that the current kernel thread is about to block until some specified event occurs. You use this routine with the `thread_block` routine, which actually blocks (puts to sleep) the current kernel thread.

- `thread_block`

Call this routine to block the current kernel thread and select the next kernel thread to start.

These routines are described in the following sections.

9.4.1 Asserting That the Current Kernel Thread Is About to Block Until the Specified Event Occurs

To assert that the current kernel thread is about to block until some specified event occurs, call the `assert_wait_mesg` routine. To actually block (put to sleep) the current kernel thread, call `thread_block`.

The following code fragment shows a call to `assert_wait_mesg` and `thread_block` by the `if_fta` module's `fta_error_recovery` routine. The `fta_error_recovery` routine is a kernel thread that starts up when the adapter becomes operational. This kernel thread resets the adapter if a fatal error occurs. The code fragment also shows the code that contains the call to `kernel_thread_w_arg`, which calls `fta_error_recovery`.

```

:
:
#include <kern/thread.h> 1
:
:
#define ADAP "fta"
:
:
extern task_t first_task; 2
:
:
struct fta_kern_str {
:
:
short reinit_thread_started; /* reinit thread running? */
:
:
short error_recovery_flag; /* flag to wake up a process */
:
:
}; 3
:
:
struct ifnet {
:
:
short if_unit; /* subunit for lower-level driver */
:
:
};
:
:
fta_transition_state(struct fta_kern_str *sc,
                    short unit,
                    short state)
{
:
:
:
switch(state) {
:
:
:
case PI_OPERATIONAL: {
int s;
NODATA_CMD *req_buff;
thread_t thread; 4
:
:
if (sc->reinit_thread_started == FALSE) { 5

```

```

        thread = kernel_thread_w_arg(first_task,
                                    fta_error_recovery,
                                    (void *)sc); [6]

        if (thread == NULL) { [7]
            printf("%s%d: Cannot start error recovery thread.\n",
                  ADAP, ifp->if_unit);
        }
        sc->reinit_thread_started = TRUE;
    }
:
:
void fta_error_recovery(struct fta_kern_str *sc) [8]
{
    struct ifnet *ifp;

    /*
     * Collect the argument left by the kernel_thread_w_arg().
     */
    ifp = &sc->is_if;

    for(;;) { [9]
        assert_wait_mesg((vm_offset_t)&sc->error_recovery_flag,
                        TRUE, "ftaerr"); [10]
        thread_block(); [11]
    }

    /* Performs tasks to reset the adapter */
    :
    :
}
:
:
}

```

- [1]** Includes the header file `/usr/sys/include/kern/thread.h`. The `thread.h` file defines structures that kernel thread routines use.
- [2]** Declares a pointer to a task structure and calls it `first_task`. Every kernel thread must be part of a task. You pass this pointer to the `kernel_thread_w_arg` routine.
- [3]** Defines an `fta_kern_str` data structure. The example shows only the fields related to the discussion of the `kernel_thread_w_arg`, `assert_wait_mesg`, and `thread_block` routines.
- [4]** Declares a pointer to a thread structure and calls it `thread`. This variable stores the thread structure pointer returned by `kernel_thread_w_arg`.
- [5]** If the reinitialized kernel thread evaluates to `FALSE` (the reinit kernel thread is not running), calls the `kernel_thread_w_arg` routine.
- [6]** Calls the `kernel_thread_w_arg` routine.

The `kernel_thread_w_arg` routine takes three arguments:

- The first argument specifies a pointer to a task structure. This pointer identifies the task in which the `kernel_thread_w_arg` routine starts the newly created kernel thread. In this call, the `fta_transition_state` routine passes a task structure called `first_task`.

- The second argument specifies a pointer to a routine that is the entry point for the newly created kernel thread. In this call, the entry point for the newly created kernel thread is the `fta_error_recovery` routine. The `fta_error_recovery` routine is a kernel thread that starts up when the adapter becomes operational. This kernel thread is responsible for resetting the adapter in the event of a fatal error.
- The third argument specifies an argument that `kernel_thread_w_arg` passes to the entry point specified in the second argument. In this call, the `fta_transition_state` routine passes a pointer to the `fta_kern_str` structure. The `fta_error_recovery` routine performs a variety of tasks that require the `fta_kern_str` structure.

7 Upon successful completion, `kernel_thread_w_arg` returns a pointer to the thread structure associated with the kernel thread started at the specified entry point. Kernel modules can use this pointer as a handle to a specific kernel thread in calls to other kernel thread routines.

The `fta_transition_state` routine checks the return. If the return is `NULL`, `kernel_thread_w_arg` did not create the error recovery kernel thread. The `fta_transition_state` routine calls `printf` to display an appropriate message on the console terminal. If the return is not `NULL`, `fta_transition_state` sets the `reinit_thread_started` field to the value `TRUE` to indicate that the error recovery kernel thread is started.

8 The `fta_error_recovery` routine is a kernel thread that starts up when the adapter becomes operational. This kernel thread resets the adapter if a fatal error occurs.

A fatal error requires resetting the adapter; this error is discovered during a device interrupt. It is necessary to block in the interrupt service routine while resetting the adapter. Because it is not legal to block in an interrupt service routine, the `fta_transition_state` calls this kernel thread to perform the reset operation on the adapter.

The `kernel_thread_w_arg` routine passes the `kern_str` structure pointer to `fta_error_recovery`.

9 Sets up an infinite loop that executes when the adapter becomes operational.

10 Calls the `assert_wait_mesg` routine to assert that the current kernel thread is about to block (sleep).

The `assert_wait_mesg` routine takes three arguments:

- The first argument specifies the event associated with the current kernel thread. In this call, the event associated with the current kernel thread is stored in the `error_recovery_flag` field.
- The second argument specifies a Boolean value that indicates how the kernel thread is awakened. You can pass one of the following values:

TRUE	The current kernel thread is interruptible. This value means that a signal can awaken the current kernel thread.
FALSE	The current kernel thread is not interruptible. This value means that only the specified event can awaken the current kernel thread.

In this call, the value `TRUE` is passed.

- The third argument specifies a mnemonic for the type of wait. The `/bin/ps` command uses this mnemonic to print out more meaningful messages about a process. In this call, the `fta_error_recovery` routine passes the string `ftaerr`.

The `assert_wait_mesg` routine does not return a value.

- [11]** Calls the `thread_block` routine. The `thread_block` routine blocks (puts to sleep) the current kernel thread and selects the next kernel thread to start (run). The routine schedules the next kernel thread onto this CPU.

The `thread_block` routine does not return a value.

9.4.2 Using the Symmetric Multiprocessor Sleep Routine

To block the current kernel thread, call the `mpsleep` routine—the symmetric multiprocessor (SMP) sleep call. The following code fragment shows a call to `mpsleep` by the `if_fta` module's `fta_error_recovery` routine. The `fta_error_recovery` routine is a kernel thread that starts up when the adapter becomes operational. This kernel thread resets the adapter if a fatal error occurs. The code fragment also shows the use of a simple lock with the `mpsleep` routine.

```

:
:
struct fta_kern_str {
:
:
short error_recovery_flag; /* flag to wake up a process */
:
:

```



```

int is_state; 1
simple_lock_data_t lk_fta_kern_str; 2
:
:
};
:
:
void fta_error_recovery(struct fta_kern_str *sc)
{
    struct ifnet *ifp;

    /*
     * Collect the argument left by the kernel_thread_w_arg().
     */
    ifp = &sc->is_if;
    simple_lock (&sc->lk_fta_kern_str); 3
    while (sc->is_state == RUN_NOT) { 4

        for(;;) { 5
            mpsleep ((vm_offset_t)&sc->error_recovery_flag, PCATCH,
                    "ftaerr", 0, &sc->lk_fta_kern_str,
                    MS_LOCK_SIMPLE | MS_LOCK_ON_ERROR) 6
        }
    }
}
:
:

```

- 1** Declares a field to hold state flags.
- 2** Declares a simple lock structure pointer as a field of the `fta_kern_str` structure to protect the integrity of the data stored in the fields of this structure. Assume that this simple lock was initialized in the example kernel module's `attach` routine. The `fta_error_recovery` routine passes this simple lock structure pointer to the `mpsleep` routine.
- 3** Calls the `simple_lock` routine to assert an exclusive access on the following code block.
- 4** While the `is_state` flag is equal to the `RUN_NOT` flag, execute the for loop.
- 5** Sets up an infinite loop that executes when the `is_state` flag is equal to the `RUN_NOT` flag.
- 6** Calls the `mpsleep` routine to block (put to sleep) the current kernel thread.

The `mpsleep` routine takes six arguments:

- A channel argument

The channel argument specifies an address associated with the calling kernel thread to be put to sleep. In this call, the address (or

event) associated with the current kernel thread is stored in the `error_recovery_flag` field.

- A `pri` argument

The `pri` argument specifies whether the sleep request is interruptible. Setting this argument to the `PCATCH` flag causes the process to sleep in an interruptible state (that is, the kernel thread can take asynchronous signals). Not setting the `PCATCH` flag causes the process to sleep in an uninterruptible state (that is, the kernel thread cannot take asynchronous signals).

In this call, `fta_error_recovery` passes the value `PCATCH`.

- A `wmesg` argument

The `wmesg` argument specifies the wait message.

In this call, `fta_error_recovery` passes the string `ftaerr`.

- A `timo` argument

The `timo` argument specifies the maximum amount of time the kernel thread should block (sleep). If you pass the value 0 (zero), `mpsleep` assumes there is no timeout.

In this call, `fta_error_recovery` passes the value 0 (zero) to indicate there is no timeout.

- A `lockp` argument

The `lockp` argument specifies a pointer to a simple or complex lock structure. You pass a simple or complex lock structure pointer if you want to release the lock. If you do not want to release a lock, pass the value 0 (zero).

In this call, `fta_error_recovery` passes the address of the simple lock.

- A `flags` argument

The `flags` argument specifies the lock type. You can pass the bitwise inclusive OR of the valid lock bits defined in `/usr/sys/include/sys/param.h`.

In this call, `fta_error_recovery` passes the bitwise inclusive OR of the lock bits `MS_LOCK_SIMPLE` (calls `mpsleep` with a simple lock asserted) and `MS_LOCK_ON_ERROR` (forces `mpsleep` to relock the lock on failure). You would specify these bits only if you pass a simple or complex lock.

The `mpsleep` routine blocks (puts to sleep) the current kernel thread until a wakeup is issued on the address you specified in the `channel` argument. The kernel thread blocks a maximum of `timo` divided by `hz` seconds. The value 0 (zero) means there is no timeout.

If you pass the `PCATCH` flag to the `pri` argument, `mpsleep` checks signals before and after blocking. Otherwise, `mpsleep` does not check signals.

The `mpsleep` routine allows you to specify a pointer to a simple or complex lock structure that is associated with some resource. This routine unlocks this resource prior to blocking. The `flags` argument specifies the lock type. The `mpsleep` routine releases the lock when the current kernel thread successfully performs an assert wait on the specified channel.

The `mpsleep` routine returns the value 0 (zero) if awakened (success) and `EWOULDBLOCK` if the timeout specified in the `timo` argument expires (failure). On success, `mpsleep` relocks the lock if you did not set `MS_LOCK_NO_RELOCK` in `flags`. On failure, it leaves the lock unlocked. If you set the `flags` argument to `MS_LOCK_ON_ERROR`, `mpsleep` relocks the lock on failures.

9.5 Unblocking (Awakening) Kernel Threads

You can unblock (awaken) a kernel thread with the following routines:

- `thread_wakeup_one`

Call this routine to unblock the first kernel thread on the specified event.

- `thread_wakeup`

Call this routine to unblock all kernel threads on the specified event.

The following code fragment compares the calls to `thread_wakeup_one` and `thread_wakeup` by the `if_fta` module's `ftaintr` routine:

```
ftaintr(int unit)
{
    :
    :
    :     fta_transition_state(sc, unit, PI_OPERATIONAL); [1]
    :
    :
    /*****
    * Code fragment 1: Shows call to thread_wakeup_one *
    *****/
    :
    :
    :     thread_wakeup_one((vm_offset_t)&sc->error_recovery_flag); [2]
    :
}
```

- [1]** This code fragment shows the call to `fta_transition_state`. The `fta_transition_state` routine changes the state of the kernel module by performing certain fixed functions for any given state.

After `fta_transition_state` performs its tasks, it returns to `ftaintr`, which calls `thread_wakeup_one`. This routine takes an event as the first argument.

- ❷ The code fragment shows that the first argument for each of the routines specifies the event associated with the current kernel thread. It passes the address of the value stored in the `error_recovery_flag` field.

The kernel module's `fta_error_recovery` routine is the kernel thread created and started to perform error recovery tasks. The `fta_error_recovery` routine blocked on the event stored in the `error_recovery_flag` field.

```
ftaintr(int unit)
{
    :
    :
    :   fta_transition_state(sc, unit, PI_OPERATIONAL); ❶
    :
    :
    :   /*****
    :   * Code fragment 2: Shows call to thread_wakeup *
    :   *****/
    :
    :   thread_wakeup((vm_offset_t)&sc->error_recovery_flag); ❷
}

```

- ❶ This code fragments shows the call to `fta_transition_state`. The `fta_transition_state` routine changes the state of the kernel module by performing certain fixed functions for any given state.

After `fta_transition_state` performs its tasks, it returns to `ftaintr`, which calls `thread_wakeup`. This routine takes an event as the first argument.

- ❷ The code fragment shows that the first argument for each of the routines specifies the event associated with the current kernel thread. It passes the address of the value stored in the `error_recovery_flag` field.

The kernel module's `fta_error_recovery` routine is the kernel thread created and started to perform error recovery tasks. The `fta_error_recovery` routine blocked on the event stored in the `error_recovery_flag` field.

The `thread_wakeup_one` routine wakes up only the first kernel thread in the hash chain waiting for the event specified in the event argument. This routine is actually a convenience wrapper for the `thread_wakeup_prim` routine with the `one_thread` argument set to `TRUE` (wake up only the first kernel thread) and the `result` argument set to `THREAD_AWAKENED` (wakeup is normal).

The `thread_wakeup` routine wakes up all kernel threads waiting for the event specified in the `event` argument. This routine is actually a convenience wrapper for the `thread_wakeup_prim` routine with the `one_thread` argument set to `FALSE` (wake up all kernel threads) and the `result` argument set to `THREAD_AWAKENED` (wakeup is normal).

9.6 Terminating a Kernel Thread

To terminate a kernel thread, call the `thread_terminate` routine. The `thread_terminate` routine prepares to stop or permanently stops execution of the specified kernel thread. You created and started this kernel thread in a previous call to the `kernel_isrthread` or `kernel_thread_w_arg` routine. These routines return a pointer to the thread structure associated with the newly created and started kernel thread. Kernel modules use this pointer as a handle to identify the specific kernel thread that `thread_terminate` stops executing.

Typically, a kernel thread terminates itself. However, one kernel thread can terminate another kernel thread. A kernel thread that terminates itself must call `thread_halt_self` immediately after the call to `thread_terminate`. The reason for this is that `thread_terminate` only prepares the self-terminating kernel thread to stop execution. The `thread_halt_self` routine completes the work needed to stop execution by performing the appropriate cleanup work of the self-terminating kernel thread.

You do not need to terminate every kernel thread that you create. You should not terminate a kernel thread that is waiting for some event. The basic rule is that you should terminate only those kernel threads that you do not need anymore. For example, if a dynamically configured kernel module uses kernel threads, you should terminate them in the `CFG_OP_UNCONFIGURE` entry point of the loadable kernel module's `configure` routine. The kernel threads are no longer needed after the kernel module is unconfigured.

Note that the `thread_terminate` routine (for kernel threads that terminate other kernel threads) not only permanently stops execution of the specified kernel thread, but it also frees any resources associated with that kernel thread; thus, this kernel thread can no longer be used.

The following code fragment shows you how the `if_fta` kernel module's `fta_error_recovery` kernel thread terminates itself by calling `thread_terminate` and `thread_halt_self`.

The `fta_error_recovery` routine is a kernel thread that starts up when the adapter becomes operational. This kernel thread resets the adapter if a

fatal error occurs. The code fragment also shows the code that contains the call to `kernel_thread_w_arg`, which calls `fta_error_recovery`.

```

:
:
#include <kern/thread.h>
:
:
#define ADAP "fta"
:
:
extern task_t first_task;
:
:
struct fta_kern_str {
:
:
short reinit_thread_started; /* reinit thread running? */
:
:
short error_recovery_flag; /* flag to wake up a process */
:
:
};
:
:
struct ifnet {
:
:
short if_unit; /* subunit for lower-level driver */
:
:
};
:
:
fta_transition_state(struct fta_kern_str *sc,
                    short unit,
                    short state)
{
:
:
:
switch(state) {
:
:
case PI_OPERATIONAL: {
int s;
NODATA_CMD *req_buff;
thread_t err_recov_thread;

if (sc->reinit_thread_started == FALSE) {

err_recov_thread = kernel_thread_w_arg(first_task,
                                       fta_error_recovery,
                                       (void *)sc);

if (err_recov_thread == NULL) {
printf("%s%d: Cannot start error recovery thread.\n",
      ADAP, ifp->if_unit);
}
sc->reinit_thread_started = TRUE;
}

:
:
/* Perform other cases */
:
:
void fta_error_recovery(struct fta_kern_str *sc)

```

```

{
    struct ifnet *ifp;
    int ret_val;

    /*
     * Collect the argument left by the kernel_thread_w_arg().
     */
    ifp = &sc->is_if;

    for(;;) {
        assert_wait_mesg((vm_offset_t)&sc->error_recovery_flag,
            TRUE, "ftaerr");
        thread_block();
        if (current_thread()->wait_result == THREAD_SHOULD_TERMINATE) { ❶
            ret_val = thread_terminate(err_recov_thread); ❷
            thread_halt_self(); ❸
        }
    }
    :
    :
    /* Performs tasks to reset the adapter */
    :
    :
}

```

- ❶ If the `wait_result` field of the thread structure pointer associated with the current kernel thread is set to the `THREAD_SHOULD_TERMINATE` constant, there is no need to keep this error recovery kernel thread. The `fta_error_recovery` routine uses the `current_thread` routine to obtain the pointer to the currently running kernel thread.

The `current_thread` routine is a pointer to the currently running kernel thread. Typically, kernel modules use this routine to reference the `wait_result` field of the thread structure pointer associated with the currently running kernel thread. A kernel module calls `current_thread` after calls to `assert_wait_mesg` and `thread_block`. If the kernel module needs to set a timeout, then it calls `current_thread` after calls to `assert_wait_mesg`, `thread_set_timeout`, and `thread_block`.

- ❷ Calls the `thread_terminate` routine to terminate the error recovery kernel thread.

The `thread_terminate` routine takes a `thread_to_terminate` argument, which is a pointer to the thread structure associated with the kernel thread that you want to terminate. This pointer was returned in a previous call to the `kernel_isrthread` or `kernel_thread_w_arg` routine.

The `kernel_thread_w_arg` routine returns this pointer to the `err_recov_thread` variable. This variable is passed to `thread_terminate`.

Upon successfully terminating the specified kernel thread, `thread_terminate` returns the constant `KERN_SUCCESS`. If the thread structure pointer passed to the `thread_to_terminate` argument does not identify a valid kernel thread, `thread_terminate` returns the constant `KERN_INVALID_ARGUMENT`. On any other error, `thread_terminate` returns the constant `KERN_FAILURE`.

- ③ A kernel thread that terminates itself must call `thread_halt_self` immediately after the call to `thread_terminate`. The reason for this is that `thread_terminate` only prepares the self-terminating kernel thread to stop execution. The `thread_halt_self` routine completes the work needed to stop execution of the self-terminating kernel thread by performing the appropriate cleanup work.

The following code fragment shows you how the `if_fta` module's `fta_transition_state` routine terminates another kernel thread (in this example, the error recovery kernel thread) by calling only `thread_terminate`. The `fta_transition_state` routine changes the state of the kernel module by performing certain fixed tasks for a given state.

```

:
:
#include <kern/thread.h>
:
#define ADAP "fta"
:
extern task_t first_task;
:
struct fta_kern_str {
:
short reinit_thread_started; /* reinit thread running? */
:
short error_recovery_flag; /* flag to wake up a process */
:
};
:
:
struct ifnet {
:
short if_unit; /* subunit for lower-level driver */
:
};
:
:
fta_transition_state(struct fta_kern_str *sc,
                    short unit,
                    short state)
{
:
:

```



```

int ret_val;
:
:
switch(state) {
:
:
    case PI_OPERATIONAL: {
        int s;
        NODATA_CMD *req_buff;
        thread_t err_recov_thread;

        if (sc->reinit_thread_started == FALSE) {

            err_recov_thread = kernel_thread_w_arg(first_task,
                fta_error_recovery,
                (void *)sc);

            if (err_recov_thread == NULL) {
                printf("%s%d: Cannot start error recovery thread.\n",
                    ADAP, ifp->if_unit);
            }
            sc->reinit_thread_started = TRUE;
        }
:
:
/* Perform other cases */
:
:
/* After performing all other cases, no more need for the */
/* kernel thread */
    case PI_SHUTDOWN: { 1

        ret_val = thread_terminate(err_recov_thread); 2
:
:
void fta_error_recovery(sc)
    struct fta_kern_str *sc;
{
    struct ifnet *ifp;

    /*
     * Collect the argument left by the kernel_thread_w_arg().
     */
    ifp = &sc->is_if;

    for(;;) {
        assert_wait_mesg((vm_offset_t)&sc->error_recovery_flag,
            TRUE, "ftaerr");
        thread_block();
    }
:
:
/* Performs tasks to reset the adapter */
:
:
}
:
:
}

```

- 1** After the `fta_error_recovery` routine completes its work and returns to `fta_transition_state`, there is no need to keep this error recovery kernel thread. The `fta_transition_state` routine sets up a case statement to handle the termination of the error recovery kernel thread.

- 2 Calls the `thread_terminate` routine to terminate the error recovery kernel thread.

The `thread_terminate` routine takes a `thread_to_terminate` argument, which is a pointer to the thread structure associated with the kernel thread that you want to terminate. This pointer was returned in a previous call to the `kernel_isrthread` or `kernel_thread_w_arg` routine.

The `kernel_thread_w_arg` routine returns this pointer to the `err_recov_thread` variable. This variable is passed to `thread_terminate`.

Upon successfully terminating the specified kernel thread, `thread_terminate` returns the constant `KERN_SUCCESS`. If the thread structure pointer passed to the `thread_to_terminate` argument does not identify a valid kernel thread, `thread_terminate` returns the constant `KERN_INVALID_ARGUMENT`. On any other error, `thread_terminate` returns the constant `KERN_FAILURE`.

9.7 Setting a Timer for the Current Kernel Thread

To set a time delay on the current kernel thread, call the `thread_set_timeout` routine.

You must call the `thread_set_timeout` routine as follows:

1. Lock the resource.
2. Call `assert_wait_mesg` to assert that the current kernel thread is about to block.
3. Unlock the resource.
4. Call `thread_set_timeout` to set the time of delay for the current kernel thread.
5. Call `thread_block` to block (put to sleep) the current kernel thread.

The following code fragment shows a call to `thread_set_timeout` by the `if_fta` module's `fta_cmd_req` routine. This routine puts a DMA request onto the request queue of the adapter.

```
:\n:\n#include <kern/thread.h> 1\n:\n:\nstruct fta_kern_str {\n:\n:\nstruct cmd_buf *q_first; /* first in the request queue */
```

```

struct cmd_buf *q_last; /* last in the request queue */
lock_data_t cmd_buf_q_lock; /* lock for the cmdreq queue */
:
:
}; 2
:
:
short fta_cmd_req(cmdbuf, sc, command)
struct cmd_buf *cmdbuf;
struct fta_kern_str *sc;
short command;
{
:
:
    lock_write(&sc->cmd_buf_q_lock); 3
:
:
    assert_wait_mesg((vm_offset_t)cmdbuf, TRUE, "dmareq"); 4
    lock_done(&sc->cmd_buf_q_lock); 5
    thread_set_timeout(hz * 2); 6
    thread_block(); 7
:
:
}

```

1 Includes the header file `/usr/sys/include/kern/thread.h`. The `thread.h` file defines structures that kernel thread routines use.

2 Defines an `fta_kern_str` data structure.

In this example, the `fta_kern_str` structure contains the following fields:

- `q_first`
Specifies a pointer to a `cmd_buf` data structure. This field represents the first command queue in the linked list.
- `q_last`
Specifies a pointer to a `cmd_buf` data structure. This field represents the last command queue in the linked list.
- `cmd_buf_q_lock`
Declares a lock structure called `cmd_buf_q_lock`. The purpose of this lock is to protect the integrity of the data stored in the linked list of `cmd_buf` data structures. Note that the alternate name `lock_data_t` is used to declare the complex lock structure. Embedding the complex lock in the `fta_kern_str` structure protects the `cmd_buf` structure for any number of instances.

3 Calls the `lock_write` routine to lock the command request queue.

The `lock_write` routine takes one argument: a pointer to the complex lock structure `lock`. This is the lock structure associated with the resource on which you want to assert a complex lock with write access. The `fta_cmd_req` routine passes the address of the `cmd_buf_q_lock` field of the `fta_kern_str` structure pointer.

- 4] Calls the `assert_wait_mesg` routine to assert that the current kernel thread is about to block.

The `assert_wait_mesg` routine takes three arguments:

- The first argument specifies the event associated with the current kernel thread. In this call, the event associated with the current kernel thread is the `cmdbuf` structure pointer.
- The second argument specifies a Boolean value that indicates how the kernel thread is awakened. You can pass one of the following values:

`TRUE` The current kernel thread is interruptible. This value means that a signal can awaken the current kernel thread.

`FALSE` The current kernel thread is not interruptible. This value means that only the specified event can awaken the current kernel thread.

The code fragment shows that `fta_cmd_req` passes the value `TRUE`.

- The third argument specifies a mnemonic for the type of wait. The `/bin/ps` command uses this mnemonic to print out more meaningful messages about a process. The code fragment shows that `fta_cmd_req` passes the string `dmareq`.

- 5] Calls the `lock_done` routine to unlock the command request queue.

The `lock_done` routine takes one argument: a pointer to the complex lock structure `lock`. The `fta_cmd_req` routine passes the address of the `cmd_buf_q_lock` field of the `fta_kern_str` structure pointer.

- 6] Calls the `thread_set_timeout` routine to set a timer for the current kernel thread.

The `thread_set_timeout` routine takes one argument: the amount of time to wait for an event. The time is used in conjunction with the `assert_wait` routine. The `fta_cmd_req` routine passes the value `hz * 2`.

The time you specify to wait for the event is automatically canceled when the kernel thread awakes.

The `thread_set_timeout` routine does not return a value.

- 7] Calls the `thread_block` routine to block (put to sleep) the current kernel thread.

10

Building and Testing a Kernel Module

This chapter discusses how to build and test a kernel module:

- Section 10.1 describes how to produce a single binary module from your source code.
- Section 10.2 describes how to load and configure a kernel module.
- Section 10.3 describes how to prepare a kernel module to go off line (unconfiguration) and how to unload it.
- Section 10.4 describes how to statically configure a kernel module.
- Section 10.5 describes how to dynamically configure a kernel module.
- Section 10.6 describes how to create the `sysconfigtab` file fragment.
- Section 10.7 describes how to change attribute values at run time.
- Section 10.8 describes how to test a kernel module.

10.1 Producing a Single Binary Module

Before you can statically or dynamically load a kernel module, you must produce the single binary module. A single binary module is the executable image of the kernel module that can be statically or dynamically brought into the kernel. A single binary module has a file extension of `.mod`. To produce the single binary module, perform the steps described in the following sections.

10.1.1 Step 1: Create a Directory to Contain Kernel Module Files

Use the `mkdir` command to create a directory to contain the kernel module files:

```
# mkdir /usr/sys/ExampMod
```

In this example, the kernel module writer creates the directory called `/usr/sys/ExampMod` to contain the files related to the `example` kernel module. Note that the writer performs the work at the superuser prompt.

When you create your directory, replace `ExampMod` with a directory that reflects a name specific to your organization or company.

10.1.2 Step 2: Copy Kernel Module Files

Use the `cp` command to copy the files to the directory you created in Section 10.1.1:

```
# cd /usr/sys/ExampMod [1]
# cp /usr/sys/mydevelopment/example.c . [2]
# cp /usr/sys/mydevelopment/files .
# cp /usr/sys/mydevelopment/sysconfigtab .
```

- [1] Change to the directory (in this example, the `/usr/sys/ExampMod` directory), into which you will copy the kernel module files.
- [2] Copy the `example.c` source file associated with your kernel module to the directory you specified in Section 10.1.1 (in this example, the `/usr/sys/ExampMod` directory). The `/usr/sys/mydevelopment` directory is where the kernel module writer initially created the `example.c` file.

You should have implemented the module's `configure` routine to follow the single binary module model (that is, your module is both static and dynamic).

10.1.3 Step 3: Create a BINARY.list File

Use an editor such as `vi` to create a `BINARY.list` file:

```
# cd /usr/sys/conf [1]
# vi BINARY.list [2]
```

- [1] Change to the `/usr/sys/conf` directory.
- [2] Use the `vi` or another editor to create the `BINARY.list` file.

The following example shows the contents of the `BINARY.list` file that the kernel module writer creates:

```
/usr/sys/ExampMod:
```

The contents is the directory path where you placed the kernel module files (see Section 10.1.1). For this example, the directory is:

```
/usr/sys/ExampMod:
```

Replace the path and source file name with the path and source file name associated with your kernel module. You must follow the path and source file name with a colon (:), as shown in the example.

10.1.4 Step 4: Run the sourceconfig Program

Run the `sourceconfig` program from the `/usr/sys/conf` directory:

```
# cd /usr/sys/conf [1]
# ./sourceconfig BINARY [2]
```

- [1] Change to the `/usr/sys/conf` directory before running the `sourceconfig` program.
- [2] Invoke the `sourceconfig` program followed by the `BINARY` configuration file name. This generates a new Makefile in the `/usr/sys/BINARY` directory. This Makefile contains the information necessary to compile the single binary module or modules defined in the `BINARY.list` file and the `files` file fragment. Section 10.1.3 tells you how to create a `BINARY.list` file in the `/usr/sys/conf` directory. Your `files` file fragment resides in the directory that you created in Section 10.1.1.

10.1.5 Step 5: Run the make Program

Run the `make` program from the `/usr/sys/BINARY` directory:

```
# cd /usr/sys/BINARY [1]
# make example.mod [2]
```

- [1] Change to the `/usr/sys/BINARY` directory before running the `make` program.
- [2] Invoke the `make` program followed by the name of your kernel module plus the `.mod` extension. This step creates the single binary module in the `/usr/sys/BINARY` directory. In the example, `example.mod` is the single binary module for the `example` module, created in the `/usr/sys/BINARY` directory. This step also creates a link from the `/usr/sys/BINARY` directory to the directory you created in Section 10.1.1.

Invoke the `make` program for each module you want to compile. The appropriate links are created as described in the previous paragraph.

10.1.6 Step 6: Create a Kernel Configuration Development Area

Use an editor such as `vi` to create a `sysconfigtab` file fragment (see Section 10.6).

Run the `doconfig` program from the `/usr/sys/conf` directory to create a kernel configuration development area:

```
# cd /usr/sys/conf [1]
# doconfig [2]
```

- [1] Change to the `/usr/sys/conf` directory.
- [2] Invoke the `doconfig` program.

Enter the name of the target configuration file at the following prompt:

```
*** KERNEL CONFIGURATION AND BUILD PROCEDURE ***  
Enter a name for the kernel configuration file. [CONRAD]: EXAMPMOD
```

In order to test your kernel module, enter a new name for the target configuration file. In this example, the kernel module writer enters the target configuration file name EXAMPMOD. Giving the `doconfig` program a new target configuration file name allows your existing target configuration file to remain on the system. You can then use the new target configuration file to configure a system that contains the kernel module you are testing.

Select the option from the menu that indicates you are adding no new kernel options.

Indicate that you do not want to edit the target configuration file in response to the following prompt:

```
Do you want to edit the configuration file? (y/n) [n] no
```

10.1.7 Step 7: Run the `sysconfigdb` Utility

Run the `sysconfigdb` utility to configure the single binary module's attributes:

```
# cd /usr/sys/ExampMod 1  
# sysconfigdb -a -f sysconfigtab example 2
```

- 1 Change to the the directory that you created in Section 10.1.1 (in this example, the `/usr/sys/ExampMod` directory).
- 2 Invoke the `sysconfigdb` utility. In this example, the `sysconfigdb` utility is invoked with the following flags:
 - The `-a` flag
Specifies that `sysconfigdb` add the kernel module entry to the `/etc/sysconfigtab` database.
 - The `-f` flag
Specifies the flag that precedes the `sysconfigtab` file fragment whose device driver entry is to be added to the `/etc/sysconfigtab` database. This flag is used with the `-a` flag.
 - The kernel module name
Specifies the name of the kernel module, `example`.
You should replace `example` with the name of your kernel module.

10.2 Loading and Configuring a Kernel Module

Kernel module configuration consists of the tasks necessary to incorporate modules into the kernel to make them available to other resources. Chapter 2 described two methods of kernel module configuration:

- Static configuration consists of the tasks and tools necessary to load a single binary kernel module (that is, a `.mod` file created from your source `.c` file) directly into the kernel at kernel build time (see Section 10.2.1).
- Dynamic configuration consists of the tasks and tools necessary to load a single binary kernel module directly into the kernel at any point in time (see Section 10.2.2).

Section 10.1 describes how to create a single binary module and then how to statically and dynamically configure the kernel module into the kernel. This section discusses the following module configuration and loading operations:

- Loading a module into the kernel image, which makes the module's binary code part of the kernel (see Section 10.2.1).
- Loading a kernel module dynamically (see Section 10.2.2).

Configuring the kernel module, which initializes the attribute table and registers the module's entry points, is described in Chapter 2 and Chapter 3.

10.2.1 Loading a Module into the Kernel Image

You can statically load a single binary module into the kernel as follows:

- By running the `doconfig` program
This program generates a bootable kernel (`/vmunix`), which consists of either a list of modules or a binary image. This method is used for devices that are required at system startup, such as the console terminal, disks, and graphics devices.
- By running the `osfboot` program
This program loads the kernel at system startup. If the kernel is a binary image, `osfboot` simply boots the image. If the kernel is a list of modules, `osfboot` links the modules, then boots the new kernel image.

10.2.2 Loading a Kernel Module Dynamically

You can dynamically load a single binary module into the kernel as follows:

1. Make sure your single binary module exists in the `/sys/BINARY` directory.
2. Log in as superuser (the root user).
3. Run the `sysconfig -c module_name` command, where `module_name` is the name of your kernel module.

10.3 Unconfiguring and Unloading Kernel Modules

The module framework defines the rules for preparing a kernel module to go off line (unconfiguration) and for unloading. As described in Section 2.2.2, when a kernel module's `configure` routine receives the `CFG_OP_UNCONFIGURE` request from the module framework, it prepares the module for unconfiguration and unloading. These tasks are part of the same process that initiates when the `CFG_OP_UNCONFIGURE` request is received. However, the results of unconfiguring and unloading are different, depending on whether your kernel module was statically loaded or dynamically loaded.

Unconfiguration can occur both at single-user and at multiuser time and only at the user's request. Only dynamically loaded kernel modules are completely removed from the system—that is, the module image is removed from the kernel. Statically loaded kernel modules are taken off line and made unavailable to other modules and system resources. When the user unconfigures and unloads a static kernel module, the module is not removed from the kernel image. In this sense, it is not really unloaded the way dynamic modules are.

Use the following command to unconfigure and unload (in the case of dynamic modules) a kernel module. Note that you must be a superuser to perform this task.

```
# sysconfig -u example
```

10.4 Statically Configuring a Single Binary Module

After creating a single binary module, you can statically configure it into the kernel as follows:

- Statically configure a single binary module into a `/vmunix` kernel
- Statically configure a single binary module into a `/sysconfigtab` boot-link kernel

The following sections describe the steps for each of these tasks.

10.4.1 Statically Configuring a Single Binary Module into a /vmunix Kernel

To statically configure a single binary module into a /vmunix kernel, you perform the following steps.

10.4.1.1 Step 1: Edit or Create the NAME.list File

Section 10.1.6 instructs you to create a kernel configuration development area. If your system has a /usr/sys/conf/.product.list file, then the system creates a NAME.list file. Use an editor such as vi to edit or create a NAME.list file in the /usr/sys/conf directory:

```
# cd /usr/sys/conf [1]
# vi example.list [2]
```

- [1] Change to the /usr/sys/conf directory.
- [2] Use the vi or another editor to create a NAME.list file (called example.list in this example).

You replace NAME with the name you specified for the target configuration file in Section 10.1.6.

The following example shows the contents of the example.list file the kernel module writer creates:

```
/usr/sys/ExampMod:
```

The contents of your NAME.list file is the directory you created in Section 10.1.1. You must follow the path and file name with a colon (:), as shown in the example.

10.4.1.2 Step 2: Run the doconfig Program

Run the doconfig program from the /usr/sys/conf directory to rebuild the kernel. You previously created this kernel (and associated configuration development area) in Section 10.1.6.

```
# cd /usr/sys/conf [1]
# doconfig -c EXAMPMOD [2]
```

- [1] Change to the /usr/sys/conf directory.
- [2] Invoke doconfig with the -c option and replace EXAMPMOD with the name of your target configuration file.

Enter the name of the target configuration file at the following prompt:

```
*** KERNEL CONFIGURATION AND BUILD PROCEDURE ***
Enter a name for the kernel configuration file. [CONRAD]: EXAMPMOD
```

In order to test your kernel module, enter a new name for the target configuration file. In the example, the writer enters the target configuration file name `EXAMPMOD`. Giving the `doconfig` program a new target configuration file name allows your existing target configuration file to remain on the system. You can then use the existing target configuration file to configure a system that omits the kernel module you are testing.

Select the option from the Kernel Option Selection menu that indicates you are adding no new kernel options.

In response to the following prompt, indicate that you do not want to edit the target configuration file:

```
Do you want to edit the configuration file? (y/n) [n] no
```

10.4.1.3 Step 3: Copy the New Kernel to the Root Directory

Copy the new `/vmunix` kernel into the root directory:

```
# cd / [1]
# cp /usr/sys/EXAMPMOD/vmunix /vmunix.example [2]
```

- [1] Change to the root directory.
- [2] Copy the new `/vmunix` kernel to the root directory. You should perform a similar copy operation, replacing `example` with the target configuration file name you specified in Section 10.4.1.2.

Note that the kernel module writer specifies the name `vmunix.example` as the name for the new kernel. This is typically done when testing the module. You should replace the name `example` in `vmunix.example` with some other appropriate name.

10.4.1.4 Step 4: Shut Down and Boot the System

Shut down and boot the system:

```
# shutdown -h now [1]
>>> boot -fi "vmunix.example" [2]
```

- [1] Specify the `shutdown` command with the `-h` option to shut down the system.
- [2] Specify the `boot` command followed by the `-fi` options and the name of the new kernel, replacing `vmunix.example` with the name of the kernel you copied to the root directory in Section 10.4.1.3.

The kernel module product (single binary module) is now part of this new kernel. You can test it with the appropriate utilities.

10.5 Dynamically Configuring a Single Binary Module

This section describes the procedure to dynamically configure a single binary module into the kernel.

10.5.1 Step 1: Link to the Single Binary Module

Run the `ln` command to link the single binary module attributes:

```
# cd /var/subsys 1
# ln -s /usr/sys/BINARY/example.mod example.mod 2
```

- 1 Change to the `/var/subsys` directory.
- 2 Create a symbolic link. In this example, the source of the link is `/usr/sys/BINARY/example.mod` and the destination is `example.mod`.

You should also create a symbolic link by replacing `example` with the name of your kernel module.

10.5.2 Step 2: Link to the Method File

Run the `ln` command to link to the method file:

```
# pwd 1
/var/subsys
# ln -s /subsys/device.mth example.mth 2
```

- 1 Use the `pwd` command to make sure the working directory is `/var/subsys`. The `pwd` command displays `/var/subsys`, the directory you changed to in Section 10.5.1.
- 2 Create a symbolic link. In this example, the source of the link is `/subsys/device.mth` and the destination is `example.mth`.

You should also create a symbolic link by replacing `example` with the name of your kernel module.

10.5.3 Step 3: Run the `sysconfig` Utility

Use the `sysconfig` utility with the `-c` option to load the single binary module:

```
# sysconfig -c example
```

Replace `example` with the name of your kernel module. The `-c` option configures the single binary module into the kernel and creates the device special files (for device driver modules).

10.6 Creating the `sysconfigtab` File Fragment

Users can configure attributes at run time. Any configurable attributes, or attributes that users can query, are defined in `/etc/sysconfigtab`.

You should supply initial values for your kernel module's configurable attributes in a `sysconfigtab` file fragment. The `sysconfigtab` file

fragment is an ASCII file. The `sysconfigdb` utility appends the `sysconfigtab` file fragment to the customer's `/etc/sysconfigtab` file when the kernel module is installed on the system. Using `sysconfigdb` ensures that users never manually edit the `etc/sysconfigtab` file.

Figure 10–1 shows the format of the entries in the `sysconfigtab` file fragment.

Figure 10–1: Format of the `sysconfigtab` File Fragment

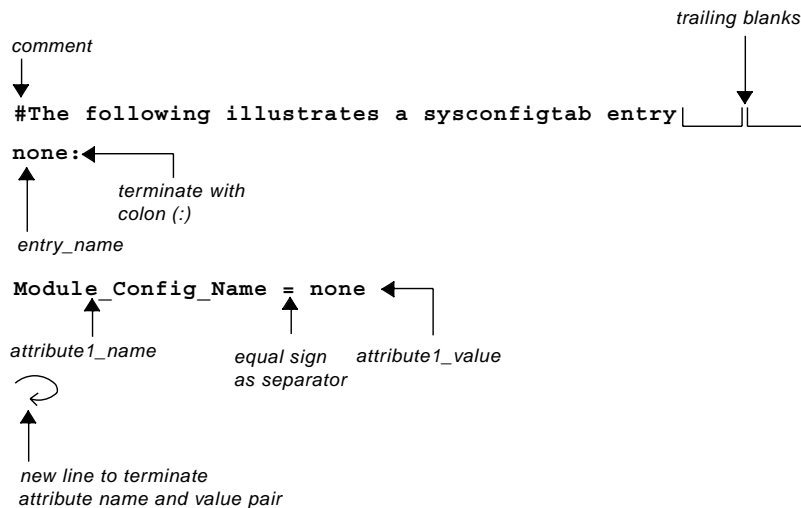

ZK-0566U-AI

Each entry contains the following information:

- **Comments**
A number sign (#) at the beginning of a line indicates a comment. You can include comments at the beginning or the end of a kernel module `sysconfigtab` entry. Comments are not allowed within the body of the `sysconfigtab` entry.
- **Blank spaces**
Tabs are allowed at the beginning or end of lines, and trailing blanks are allowed at the end of lines.
- *entry_name*
Specifies the name of the kernel module, followed by a colon (:). Typically, each module contains a separate `sysconfigtab` file entry. The *entry_name* must match the `Module_Config_Name` defined in the module attribute table.
- *attribute_name = attribute_value*

Specifies an attribute and its value. A valid `sysconfigtab` entry consists of a attribute name, an equal sign (=), and one or more values. Each attribute name and value pair should appear on a separate line.

The following restrictions apply to `sysconfigtab` file fragments:

- An individual `sysconfigtab` entry can be a maximum of 40960 bytes long. The system ignores all bytes in excess of this limit.
- An individual line (attribute) within a `sysconfigtab` entry cannot exceed 1548 bytes.
- An individual `sysconfigtab` entry cannot consist of over 2048 lines.
- At least one blank line is required between `sysconfigtab` entries.

Example 10–1 shows the `sysconfigtab` file fragment for a device driver kernel module (in this example, `temp` driver). The development tool generates all of the necessary attribute entries; only the `TEMP_Developer_Debug` attribute was added to the file. The `sysconfigtab` file fragment does not specify a value for the `Device_Dir` attribute. Therefore, the device special file for the `temp` module resides in the `/dev` directory.

Example 10–1: A `sysconfigtab` File Fragment

```
# /usr/sys/io/TEMP/sysconfigtab
# sysconfigtab file fragment for temp driver
temp: ❶
    Module_Config_Name = temp      ❷
    ❸ PCI_Option = PCI_SE_Rev - 0x210, Vendor_Id - 0x1002, Device_Id -
0x4354, Rev - 0, Base - 0, Sub - 0, Pif - 0 Sub_Vid - 0, Sub_Did - 0, Vid_Mo_Flag -
1, Did_Mo_Flag - 1, Rev_Mo_Flag - 0, Base_Mo_Flag - 0, Sub_Mo_Flag -
0, Pif_Mo_Flag - 0, Sub_Vid_Mo_Flag - 0, Sub_Did_Mo_Flag - 0, Driver_Name -
temp, Type - C, Adpt_Config - N
    ISA_Option = Board_Id - Null, Function_Name - 'TEMP' , Driver_Name -
temp, Type - C, Adpt_Config - N
    EISA_Option = Board_Id - TEMP, Function_Name - Null, Driver_Name -
temp, Type - C, Adpt_Config - N
#
# Initialize driver-specific attributes
#
    TEMP_Developer_Debug = 1      ❹
```

- ❶ Indicates that the attributes that follow belong to the `temp` module.
- ❷ Initializes the `Module_Config_Name` attribute to `temp`. This is the string that the module framework uses to identify the configure routine and attribute table for the kernel module.
- ❸ Initializes the bus option data for the PCI, ISA, and EISA buses. The driver in this example is designed to operate on these three types of buses.

- 4 Initializes the `TEMP_Developer_Debug` attribute to 1, which turns on debugging messages.

10.7 Changing Attribute Values at Run Time

Users, especially system administrators, may sometimes want to change attributes. You may also need to change an attribute value during kernel module development to test features of the kernel module. The `sysconfig` program allows you and your users to reconfigure a kernel module with new attribute values.

For example, the `temp` kernel module from Section 10.6 initializes the `TEMP_Developer_Debug` attribute to 1 by default, which turns debugging messages on. To turn the messages off, call the `sysconfig` program as follows:

```
# sysconfig -r temp TEMP_Developer_Debug=0
```

Not all attributes can be changed with `sysconfig`. To allow an attribute to change at run time, you must assign the `CFG_OP_RECONFIGURE` constant to the operation member of the attribute's `cfg_subsys_attr_t` data structure. The `sysconfig` program returns an error if you try to change an attribute that does not have this operation value.

The `sysconfig` program calls the module framework to change the value stored in memory. The module framework then calls the kernel module's `configure` entry point to perform any other operations required to reconfigure the module.

10.8 Testing a Kernel Module

After you have statically or dynamically configured your module into the kernel, you should test it. There are many ways to test the functioning of your kernel module that depend on the purpose and function of your kernel module. If your module is a device driver, see *Writing Device Drivers* for specific information on testing device drivers. The following list provides some general suggestions for testing kernel modules:

- Include `printf` statements in your module code that may be removed later. When you run your module, verify that each part of the processing succeeds.
- If your module is an application program interface (API), write a program to test it.

Glossary

alignment

The placement of a data item in memory. For a data item to be aligned, its lowest-addressed byte must reside at an address that is a multiple of the size of the data item (in bytes).

API

Application programming interface.

argument

See **parameter**.

atomicity

A type of serialization that refers to the indivisibility of a small number of actions, such as those occurring during the execution of a single instruction or a small number of instructions.

attribute table

An array of the `cfg_subsys_attr_t` data structure, where each instance of `cfg_subsys_attr_t` represents one table entry defining some data item for the kernel module.

boot timeline

The series of events and dispatch points that occur as the system boots. For example, at dispatch point `CFG_PT_VM_AVAIL` virtual memory is available. See also **dispatch point**.

class/port driver

The class/port driver comprises two drivers. The class driver supports user interfaces while the port driver supports the hardware and handles interrupts. The driver model is always made of more than one module and it can have multiple class drivers, multiple port drivers, and some common code in a middle layer. The structure of this driver eliminates code duplication.

complex lock

A mechanism for protecting resources in an SMP environment. A complex lock achieves the same result as a simple lock but is used when there are blocking conditions. Routines that implement complex locks synchronize

access to kernel data between multiple kernel threads. See also **simple lock**.

device driver

A kernel module that supports one or more hardware components. There are two driver models: the **monolithic driver** and the **class/port driver**.

dispatch point

Points along the boot timeline and post-boot that mark when certain resources or capabilities are available. Dispatch points initiated from user space can occur in any order. In kernel mode, these points are in strict chronological order. For example, the dispatch point indicating that virtual memory is available (`CFG_PT_VM_AVAIL`) always occurs before locks are available (`CFG_PT_LOCKAVAIL`).

dynamic mode

The ability to add or remove software or hardware while the system is operational. For example, dynamic hardware configuration and dynamic module loading occur late in the boot timeline once these features are enabled. Contrast with **static mode**.

entry point

The address of a routine.

granularity

The size of neighboring units of memory that can be written independently and atomically by multiple CPUs. See also **atomicity**.

initialization

The tasks that incorporate a kernel module into the kernel after it has been loaded and make it available for use by the system.

interface

A collection of routine definitions and data structures that perform related functions. There are kernel interfaces and user interfaces. For example, the kernel set management (KSM) interface consists of a variety of `cfg_ksm_XXX` library routines that allow applications to manage the kernel sets. See also **routine**.

kernel module

The code and data structures in a `.mod` file, either statically linked into `/vmmunix` or dynamically loaded as part of the kernel.

kernel thread

A single, sequential flow of control within a program.

load

The process of bringing a kernel module into memory and calling its `configure` routine with the `CFG_OP_CONFIGURE` request code.

lock

A means of protecting a resource from multiple CPU access in an SMP environment. See also **simple lock** and **complex lock**.

module

See **kernel module**.

module framework

The subsystem in the kernel that loads, unloads, makes other management requests, and generally keeps track of modules in the kernel.

monolithic driver

Kernel module code that is all-inclusive; supporting everything from user requests to processing interrupts from hardware.

parameter

A variable or constant associated with some value that is passed to a routine. Also called an argument.

pseudodevice driver

A driver, such as the `pty` terminal driver, structured like other drivers but not operating on a bus and not controlling hardware. A pseudodevice driver does not register itself in the hardware topology (system configuration tree). Instead, it relies on the device driver method of the `cfgmgr` framework to create the associated device special files.

routine

Code that can be called to perform a function. See also **interface**.

scan

The process of looking for hardware components for the purpose of configuring hardware that is not currently configured.

simple lock

A general-purpose mechanism for protecting resources in an SMP environment. A simple lock is a spin lock. That is, routines that implement simple locks do not return until the lock has been returned. See also **complex lock**.

single binary image

A single `.mod` file that can be statically loaded as part of `/vmunix` or dynamically loaded into the kernel any time after a system boots.

SMP

Symmetric multiprocessing.

software synchronization

The coordination of events in such a way that only one event happens at a time.

static mode

The permanent and nonremovable parts of the kernel. Contrast with **dynamic mode**.

string

An array of characters terminated by a null character.

subsystem

A collection of code that provides one or more interfaces or performs one or more functions.

symmetric multiprocessing

A computer environment that uses two or more central processing units (CPUs). Software applications and the associated kernel modules can operate on two or more of these CPUs.

thread

See **kernel thread**.

Index

A

alignment, 6-3
Alpha CPU
 accessing CSR addresses, 6-14
 alignment, 6-3
 granularity of data access, 6-3
 hardware-level synchronization, 6-1
application
 converting kernel timestamps to a string, 5-25
assert_wait_mesg routine, 9-11
atomicity, 6-2
attribute
 operations allowed on, 3-3
attribute data types, 3-3
attribute table, 3-1
 creating, 1-6
 entry, 3-1, 3-2
 get request, 3-4
 operation field, 3-3
 set request, 3-6

B

b_resid field
 use as argument with copyin routine, 5-10
bcopy routine, 5-7
 explanation of code fragment, 5-8
 results of example calls, 5-8
blocking conditions
 using complex locks, 6-8
blocking lock, 6-8
boot path
 (*See boot timeline*)

boot timeline, 4-1
 dispatch point, 4-3
 understanding, 4-1
buf data structure, 6-16
BUF_LOCK routine, 6-17
BUF_UNLOCK routine, 6-17
building a kernel module, 10-1
busy wait time, 6-11
byte string
 copying bcopy routine, 5-7
bzero routine
 explanation of code fragment, 5-9

C

callback, 1-6
 coding, 4-4, 4-7
 deregistering, 4-8
 dispatch point, 4-1
 nesting, 4-8
 using, 4-2
 writing, 4-7
calling process
 putting to sleep, 5-14
cfg_attr_t routine, 3-1
CFG_OP_CONFIGURE, 2-3, 2-5
CFG_OP_QUERY, 2-3
CFG_OP_RECONFIGURE, 2-3
CFG_OP_UNCONFIGURE, 2-3, 2-7
cfg_subsys_attr_t routine, 3-2
code block
 choosing lock method by size of, 6-11
 identifying those that manipulate resource, 6-18
complex lock, 6-8, 8-1

- access operations, 8-4
- asserting, 8-4
 - read-only access, 8-4
 - write access, 8-7
- choosing when to use, 6-9
- declaring data structure, 8-1
- execution speed, 6-11
- initializing, 8-2
- releasing previously asserted, 8-10
- terminating, 8-19
- trying to assert, 8-13
 - read-only access, 8-14
 - write access, 8-16
- complex lock data structure, 6-9
 - declaring, 8-1
 - initializing, 8-2
- complex lock routine, 6-9, 8-1
- configuration point
 - (*See dispatch point*)
- configure routine, 2-1, 2-3, 2-4, 3-3, 3-4, 4-2
 - parameters, 2-2
- console
 - printing text to, 5-13
- control status register
 - (*See CSR*)
- controller data structure, 6-16
- convenience wrapper
 - for `thread_create` and `thread_start` routines, 9-6
- copyin routine
 - explanation of code fragment, 5-9
 - results of example call, 5-10
- copyout routine
 - explanation of code fragment, 5-11
 - results of example call, 5-11
- cpu global variable, 6-16
- CSR
 - access methods, 6-14
- CSR I/O access routines
 - `read_io_port`, 6-14
 - `write_io_port`, 6-14

ctime function, 5-25

D

- data
 - granularity, 6-3
 - integrity, 6-4
 - natural alignment, 6-3
- data copying routines, 5-7
- data structure
 - allocating memory, 2-7
 - `buf`, 6-16
 - controller, 6-16
 - `ihandler_t`, 6-16
 - kernel thread, 9-6
 - module-specific, 6-15
 - simple lock, 7-1
 - task, 9-6
 - thread, 9-3
 - used by kernel thread routines, 9-5
- data type
 - attribute, 3-3
- deadlock
 - and kernel threads, 9-4
- `decl_simple_lock_data` routine, 7-1
- DECthreads software, 9-1
- DELAY macro
 - explanation of code fragment, 5-26
- deregistering callbacks, 4-8
- device control status register
 - (*See CSR*)
- device register offset definitions
 - locking, 6-19t
- direct method
 - accessing CSR addresses, 6-14
- dispatch point, 1-5
 - along boot timeline, 4-3
 - callback, 4-1
 - `CFG_PT_ENTER_SUSER`, 4-3
 - `CFG_PT_GLROOTFS_AVAIL`, 4-3
 - `CFG_PT_HAL_INIT`, 4-3

- CFG_PT_LOCK_AVAIL, 4-2, 4-3
- CFG_PT_OLD_CONF_ALL, 4-3
- CFG_PT_POSTCONFIG, 4-3
- CFG_PT_PRECONFIG, 4-3
- CFG_PT_ROOTFS_WR, 4-2
- CFG_PT_TOPOLOGY_CONF, 4-3
- CFG_PT_VM_AVAIL, 2-7, 4-1, 4-2, 4-3
 - defining in a kernel module, 4-8
 - definitions, 4-3
 - developer-defined, 4-8
- dispatch point callback, 4-1
- dynamic kernel module, 2-5

E

- error logger
 - printing text to, 5-13

F

- fetching time, 5-23

G

- global resource
 - module-specific, 6-15
 - system-specific, 6-16
- global variable
 - cpu, 6-16
 - hz, 6-16
 - lbolt, 6-16
 - module-specific, 6-15
 - system-specific, 6-16
- granularity, 6-3
 - of data access, 6-3
 - of lock, 6-20

H

- hardware issues, 6-1
- hz global variable, 6-16

I

- I/O copy routines, 6-14
 - io_copyin, 6-14
 - io_copyio, 6-14
 - io_copyout, 6-14
- ihandler_t data structure, 6-16
- indata parameter, 2-2
- indatalen parameter, 2-2
- indirect method
 - accessing CSR addresses, 6-14
- initialization, 1-6, 2-1
 - kernel module, 2-4
- initializing a timer queue element, 5-15
- interrupt priority level
 - (*See IPL*)
- interrupt priority mask
 - setting, 5-17
- interrupt service routine
 - using simple lock to synchronize with, 6-7
- IPL, 5-17

K

- kernel address space
 - copying from with copyout routine, 5-11
- kernel mode capabilities, 5-1
- kernel module, 1-1
 - attributes, 3-1
 - building and testing, 10-1
 - choosing resources to lock, 6-13
 - defining new dispatch point, 4-8
 - designing, 1-5
 - developing, 1-6
 - dynamically loaded, 2-5
 - environment, 1-2
 - initializing, 1-6, 2-1, 2-4
 - introduction, 1-1
 - kernel mode capabilities, 5-1
 - loading into the kernel image, 10-5

- making safe in SMP environment
 - using complex locks, 8-1
 - using simple locks, 7-1
- multithreaded programming, 9-1
- producing a single binary module, 10-1
- purpose of, 1-2
- required tasks for writing, 1-6
- statically loaded, 2-5
- testing, 10-12
- unconfiguring, 10-6
- unloading, 10-6
- working with time, 5-22
- kernel thread, 6-4
 - advantages of using, 9-1
 - blocking, 9-10
 - asserting current is about to block, 9-11
 - mpsleeproutine, 9-14
 - creating and starting, 9-6
 - at a specified entry point, 9-6
 - fixed-priority dedicated to interrupt service, 9-9
 - distinguishing between threads applications use, 9-1
 - execution, 9-3
 - issues related to using, 9-4
 - operations, 9-4
 - setting a timer for current, 9-24
 - states, 9-3
 - summary of routine operations, 9-4t
 - terminating, 9-19
 - unblocking, 9-17
 - using, 5-26
- kernel thread routine, 9-1
 - (*See also kernel thread*)
 - data structures, 9-5
 - task, 9-6
 - thread, 9-6
 - operations, 9-1
- kernel thread sleep

- prevention of access to resource, 6-10
- kernel_isrthread routine, 9-9
- kernel_thread_w_arg routine, 9-6
 - as convenience wrapper, 9-6

L

- lbolt global variable, 6-16
- libcfg.a library, 3-4, 3-6
- lock, 6-4
 - complex, 6-8, 8-1
 - simple, 6-6, 7-1
- lock_done routine, 8-10
- lock_init routine, 8-2
- lock_read routine, 8-4
- lock_terminate routine, 8-19
- lock_try_read routine, 8-14
- lock_try_write routine, 8-16
- lock_write routine, 8-7
- locking, 5-27
 - access to a resource, 6-10
 - choosing method, 6-9
 - choosing resources, 6-13
 - kernel module resources for, 6-17
 - length of time held, 6-10
 - SMP characteristics, 6-12
- locking device register offset
 - definitions, 6-19t
- locking methods
 - choosing, 6-9
 - comparing simple and complex locks, 6-5
 - complex lock, 6-1
 - simple lock, 6-1
 - summary of, 6-11

M

- memory
 - allocating, 2-7, 5-19
 - zeroing with bzero routine, 5-9
- memory block
 - zeroing a, 5-9

- memory space
 - used by locks, 6–11
- modifying a timestamp, 5–24
- module attribute table
 - (*See attribute table*)
- module framework, 3–3
- module initialization, 2–1
- mpsleep routine, 5–14, 9–14
- multithreaded programming, 9–1

N

- nesting callbacks, 4–8
- null-terminated character string, 5–4
 - comparing with strcmp routine, 5–1
 - copying with strcpy routine, 5–4
 - copying with strncpy routine, 5–5
 - returning with strlen routine, 5–6
- null-terminated string routine, 5–1

O

- op parameter, 2–2
- outdata parameter, 2–2
- outdatalen parameter, 2–2

P

- parameters
 - for configure routine, 2–2
- printf routine, 5–13
 - explanation of code fragment, 5–14
- printing text to the console, 5–13
- priority inversion
 - and kernel threads, 9–4
- process
 - waking up a sleeping, 5–15
- producing a single binary module, 10–1

R

- race condition
 - and kernel threads, 9–4
- realtime preemption, 6–11
- register_callback routine, 4–4, 4–5
 - parameters, 4–6
- request code, 2–3
 - CFG_OP_CONFIGURE, 2–3, 2–5, 2–6, 3–3
 - CFG_OP_QUERY, 2–3, 3–3, 3–4
 - CFG_OP_RECONFIGURE, 2–3, 3–3, 3–6
 - CFG_OP_UNCONFIGURE, 2–3, 2–7
- resource, 6–4
 - asserting exclusive access on, 7–4
 - choosing to lock in a module, 6–13
 - determining which to lock, 6–17
 - global, 6–15
 - module-specific, 6–15
 - system-specific, 6–16
 - locking, 6–5
 - read-only, 6–13
- return status values, 2–4
- routine, 9–1
 - assert_wait_mesg, 9–11
 - associated with complex locks, 6–9
 - BUF_LOCK, 6–17
 - BUF_UNLOCK, 6–17
 - callback, 4–7
 - commonly used by kernel
 - modules, 5–1
 - complex lock, 8–1
 - CSR I/O access, 6–14
 - data copying, 5–7
 - decl_simple_lock_data, 7–1
 - delaying a calling, 5–26
 - I/O copy, 6–14
 - kernel thread
 - summary of operations, 9–4t
 - kernel-related, 5–13
 - kernel_isrthread, 9–9

- kernel_thread_w_arg, 9-6
- lock_done, 8-10
- lock_init, 8-2
- lock_read, 8-4
- lock_terminate, 8-19
- lock_try_read, 8-14
- lock_try_write, 8-16
- lock_write, 8-7
- mpsleeper, 5-14, 9-14
- register_callback, 4-4, 4-5
- simple_lock, 7-4
- simple_lock_init, 7-2
- simple_lock_terminate, 7-12
- simple_lock_try, 7-9
- simple_unlock, 7-6
- spltty, 7-16
- splx, 7-16
- string, 5-1
- thread_block, 9-11
- thread_create, 9-6
- thread_halt_self, 9-19
- thread_set_timeout, 9-24
- thread_start, 9-6
- thread_terminate, 9-19
- thread_wakeup, 9-17
- thread_wakeup_one, 9-17

S

- serialization, 6-2
- shared data
 - access to, 6-4
- simple lock, 6-6, 7-1
 - asserting exclusive access on resource, 7-4
 - choosing when to use, 6-9
 - declaring data structure, 7-1
 - execution speed, 6-11
 - initializing, 7-2
 - releasing previously asserted, 7-6
 - terminating, 7-12
 - trying to obtain, 7-9
 - using spl routines, 7-15
- simple lock data structure, 6-7t

- declaring
 - decl_simple_lock_data, 7-1
 - simple_lock_data_t, 7-2
- initializing, 7-2
 - reason for declaring, 7-2
- simple lock routines, 6-7t, 7-1
- simple_lock routine, 7-4
- simple_lock_init routine, 7-2
- simple_lock_terminate routine, 7-12
- simple_lock_try routine, 7-9
- simple_unlock routine, 7-6
- single binary image, 4-2
- sleeping lock
 - (See *blocking lock*)
- SMP environment, 6-1
 - characteristics of, 6-12t
 - locking, 5-27, 6-4, 6-9
 - making kernel module safe
 - using complex locks, 8-1
 - using simple locks, 7-1
 - putting a calling process to sleep, 5-14
 - sleep call, 9-14
- software synchronization, 6-2
- spin lock
 - (See *simple lock*)
- spl routines
 - splbio routine, 5-17
 - splclock routines, 5-17
 - spldevhigh routine, 5-17
 - splxtreme routine, 5-17
 - splhigh routine, 5-17
 - splimp routine, 5-17
 - splnet routine, 5-17
 - splnone routine, 5-17
 - splrt routine, 5-17
 - splsoftclock routine, 5-17
 - spltty routine, 7-16
 - splvm routine, 5-17
 - splx routine, 5-17, 7-16
 - summarized list of, 5-18
 - uses for, 5-17
 - using, 7-15
- splbio routine

- explanation of code fragment, 5–18
 - spltty routine, 7–16
 - splx routine, 7–16
 - explanation of code fragment, 5–18
 - static kernel module, 2–5
 - status
 - return values, 2–4
 - strcmp routine, 5–1
 - explanation of code fragment, 5–2
 - results of example calls, 5–2
 - strcpy routine, 5–4
 - explanation of code fragment, 5–4
 - results of example call, 5–5
 - string operation
 - comparing null-terminated character string using strcmp routine, 5–1
 - comparing two strings using strcmp routine, 5–3
 - copying null-terminated character string using strcpy routine, 5–4
 - copying null-terminated character string using strncpy routine, 5–5
 - returning number of characters using strlen routine, 5–6
 - string routine
 - comparing two null-terminated, 5–1
 - comparing two strings, 5–3
 - copying a null-terminated character, 5–4
 - copying with specified limit, 5–5
 - returning the number of characters using strlen, 5–6
 - using, 5–1
 - strlen routine, 5–6
 - explanation of code fragment, 5–6
 - results of example call, 5–7
 - strncmp routine, 5–3
 - explanation of code fragment, 5–3
 - results of example calls, 5–3
 - strncpy routine, 5–5
 - explanation of code fragment, 5–5
 - results of example call, 5–6
 - structure
 - (*See data structure*)
 - symmetric multiprocessing environment
 - (*See SMP environment*)
 - synchronization, 6–1
 - hardware issues related to, 6–1
 - sysconfigtab file fragment
 - creating, 10–9
 - system time
 - concepts, 5–22
 - creating, 5–22
 - fetching, 5–23
 - how a kernel module uses, 5–22
 - working with, 5–21

T

- task data structure, 9–6
- testing a kernel module, 10–1
- thread
 - (*See kernel thread*)
- thread data structure, 9–3, 9–6
- thread_block routine, 9–11
- thread_create routine, 9–6
- thread_halt_self routine, 9–19
- thread_set_timeout routine, 9–24
- thread_start routine, 9–6
- thread_terminate routine, 9–19
- thread_wakeup routine, 9–17
- thread_wakeup_one routine, 9–17
- time
 - (*See system time*)
- TIME_READ macro, 5–23, 5–24
- timeout routine, 5–15
 - explanation of code fragment, 5–16

timer queue
 removing scheduled routine
 from, 5-16
timer queue element
 initializing, 5-15
timestamp
 converting to a string, 5-25
 modifying, 5-24

U

uiomove routine
 explanation of code fragment,
 5-12
untimeout routine, 5-16
 explanation of code fragment,
 5-16

user address space
 copying from, with copyin
 routine, 5-9

V

virtual space
 moving data between user and
 system with uiomove
 routine, 5-12
/vmunix, 2-5, 4-2

W

wakeup routine, 5-15
 explanation of code fragment,
 5-15

How to Order Tru64 UNIX Documentation

You can order documentation for the Tru64 UNIX operating system and related products at the following Web site:

<http://www.businesslink.digital.com/>

If you need help deciding which documentation best meets your needs, see the Tru64 UNIX *Documentation Overview* or call **800-344-4825** in the United States and Canada. In Puerto Rico, call **787-781-0505**. In other countries, contact your local Compaq subsidiary.

If you have access to Compaq's intranet, you can place an order at the following Web site:

<http://asmorder.ngo.dec.com/>

The following table provides the order numbers for the Tru64 UNIX operating system documentation kits. For additional information about ordering this and related documentation, see the *Documentation Overview* or contact Compaq.

Name	Order Number
Tru64 UNIX Documentation CD-ROM	QA-6ADAA-G8
Tru64 UNIX Documentation Kit	QA-6ADAA-GZ
End User Documentation Kit	QA-6ADAB-GZ
Startup Documentation Kit	QA-6ADAC-GZ
General User Documentation Kit	QA-6ADAD-GZ
System and Network Management Documentation Kit	QA-6ADAE-GZ
Developer's Documentation Kit	QA-6ADAG-GZ
Reference Pages Documentation Kit	QA-6ADAF-GZ

Reader's Comments

Tru64 UNIX

Writing Kernel Modules

AA-RHYGA-TE

Compaq welcomes your comments and suggestions on this manual. Your input will help us to write documentation that meets your needs. Please send your suggestions using one of the following methods:

- This postage-paid form
- Internet electronic mail: `readers_comment@zk3.dec.com`
- Fax: (603) 884-0120, Attn: UBPG Publications, ZK03-3/Y32

If you are not using this form, please be sure you include the name of the document, the page number, and the product name and version.

Please rate this manual:

	Excellent	Good	Fair	Poor
Accuracy (software works as manual says)	<input type="checkbox"/>	<input type="checkbox"/>	<input type="checkbox"/>	<input type="checkbox"/>
Clarity (easy to understand)	<input type="checkbox"/>	<input type="checkbox"/>	<input type="checkbox"/>	<input type="checkbox"/>
Organization (structure of subject matter)	<input type="checkbox"/>	<input type="checkbox"/>	<input type="checkbox"/>	<input type="checkbox"/>
Figures (useful)	<input type="checkbox"/>	<input type="checkbox"/>	<input type="checkbox"/>	<input type="checkbox"/>
Examples (useful)	<input type="checkbox"/>	<input type="checkbox"/>	<input type="checkbox"/>	<input type="checkbox"/>
Index (ability to find topic)	<input type="checkbox"/>	<input type="checkbox"/>	<input type="checkbox"/>	<input type="checkbox"/>
Usability (ability to access information quickly)	<input type="checkbox"/>	<input type="checkbox"/>	<input type="checkbox"/>	<input type="checkbox"/>

Please list errors you have found in this manual:

Page	Description
_____	_____
_____	_____
_____	_____
_____	_____

Additional comments or suggestions to improve this manual:

What version of the software described by this manual are you using? _____

Name, title, department _____

Mailing address _____

Electronic mail _____

Telephone _____

Date _____

----- Do Not Cut or Tear - Fold Here and Tape -----

COMPAQ

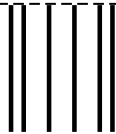

NO POSTAGE
NECESSARY IF
MAILED IN THE
UNITED STATES

BUSINESS REPLY MAIL

FIRST CLASS MAIL PERMIT NO. 33 MAYNARD MA

POSTAGE WILL BE PAID BY ADDRESSEE

COMPAQ COMPUTER CORPORATION
UBPG PUBLICATIONS MANAGER
ZKO3-3/Y32
110 SPIT BROOK RD
NASHUA NH 03062-9987

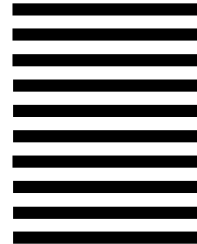

----- Do Not Cut or Tear - Fold Here -----

Cut on Dotted Line