

# Tru64 UNIX

---

## Network Administration: Services

Part Number: AA-RPPCA-TE

**June 2001**

**Product Version:** Tru64 UNIX Version 5.1A or higher

This manual is intended for experienced system or network administrators. It describes the tasks for configuring your system to operate in a network, for configuring the network services, and for day-to-day management of the network, network interfaces, and network services. This manual also includes information for solving problems that might arise while using the network and network services.

---

© 2001 Compaq Computer Corporation

COMPAQ, the Compaq logo, Compaq Insight Manager, DECnet, TruCluster, and VAX Registered in U.S. Patent and Trademark Office. OpenVMS and Tru64 are trademarks of Compaq Information Technologies Group, L.P.

Microsoft, Windows, and Windows NT are trademarks of Microsoft Corporation. Motif, OSF/1, UNIX, and X/Open are trademarks of The Open Group. All other product names mentioned herein may be trademarks of their respective companies.

Confidential computer software. Valid license from Compaq required for possession, use, or copying. Consistent with FAR 12.211 and 12.212, Commercial Computer Software, Computer Software Documentation, and Technical Data for Commercial Items are licensed to the U.S. Government under vendor's standard commercial license.

Compaq shall not be liable for technical or editorial errors or omissions contained herein. The information in this document is provided "as is" without warranty of any kind and is subject to change without notice. The warranties for Compaq products are set forth in the express limited warranty statements accompanying such products. Nothing herein should be construed as constituting an additional warranty.

---

# Contents

## About This Manual

### 1 Overview to Network Administration

|         |   |     |
|---------|---|-----|
| 1.1     | Introduction to <i>Network Administration: Services</i> ..... | 1-1 |
| 1.2     | Administrative Methods .....                                  | 1-2 |
| 1.2.1   | SysMan Menu .....   | 1-2 |
| 1.2.1.1 | Quick Setup .....   | 1-4 |
| 1.2.1.2 | Network Setup Wizard .....                                    | 1-5 |
| 1.2.1.3 | Command-Line Integration .....                                | 1-6 |
| 1.2.2   | Compaq Insight Manager .....                                  | 1-7 |
| 1.2.3   | Other Interfaces .....  | 1-8 |
| 1.2.4   | Manually Editing Configuration Files .....                    | 1-9 |
| 1.2.5   | Installation and Configuration Cloning .....                  | 1-9 |

### 2 Domain Name System

|           |  |      |
|-----------|--|------|
| 2.1       | DNS Environment .....                                      | 2-2  |
| 2.2       | Dynamic Updates .....                                      | 2-5  |
| 2.3       | Authentication of Dynamic Updates and Zone Transfers ..... | 2-6  |
| 2.4       | Planning DNS .....   | 2-6  |
| 2.4.1     | Server .....   | 2-7  |
| 2.4.2     | Client .....   | 2-9  |
| 2.5       | Configuring DNS .....                                      | 2-9  |
| 2.5.1     | Configuring a Master Server .....                          | 2-9  |
| 2.5.1.1   | Configuring an IPv6 Master Server .....                    | 2-11 |
| 2.5.1.1.1 | DNS Configuration Files .....                              | 2-11 |
| 2.5.1.1.2 | Server Guidelines .....                                    | 2-11 |
| 2.5.1.2   | Enabling Dynamic Updates to the DNS Database .....         | 2-12 |
| 2.5.2     | Configuring a Slave Server .....                           | 2-13 |
| 2.5.3     | Configuring a Caching-Only Server .....                    | 2-15 |
| 2.5.4     | Configuring a Forward-Only Server .....                    | 2-16 |
| 2.5.5     | Configuring a Stub Server .....                            | 2-18 |
| 2.5.6     | Configuring a DNS Client .....                             | 2-20 |
| 2.6       | Configuring Authentication .....                           | 2-21 |
| 2.6.1     | Configuring Secure Dynamic Updates .....                   | 2-22 |
| 2.6.2     | Configuring Secure Zone Transfers .....                    | 2-24 |

|         |  |      |
|---------|--|------|
| 2.6.3   | Authentication Example .....                         | 2-26 |
| 2.7     | Deconfiguring DNS .....                              | 2-29 |
| 2.8     | Managing DNS Servers and Clients .....               | 2-30 |
| 2.8.1   | Modifying the svc.conf File with svcsetup .....      | 2-30 |
| 2.8.2   | Updating DNS Data Files on the Master Server .....   | 2-31 |
| 2.8.3   | Obtaining Host Name and IP Address Information ..... | 2-31 |
| 2.8.3.1 | The nslookup Command .....                           | 2-32 |
| 2.8.3.2 | NIC whois Service .....                              | 2-32 |

### 3 Network Information Service

|         |  |      |
|---------|--|------|
| 3.1     | NIS Environment .....  | 3-1  |
| 3.2     | Planning NIS .....   | 3-3  |
| 3.2.1   | Verifying That the Additional Networking Services Subset<br>is Installed ..... | 3-3  |
| 3.2.2   | Preparing for the Configuration .....  | 3-3  |
| 3.2.2.1 | Master Server .....  | 3-5  |
| 3.2.2.2 | Slave Server .....   | 3-7  |
| 3.2.2.3 | Client .....   | 3-9  |
| 3.3     | Configuring NIS .....  | 3-10 |
| 3.3.1   | Configuring an NIS Master Server .....   | 3-11 |
| 3.3.2   | Configuring a Slave Server .....   | 3-15 |
| 3.3.3   | Configuring an NIS Client .....  | 3-17 |
| 3.3.4   | Modifying the svc.conf File with svcsetup .....                                | 3-19 |
| 3.3.5   | Modifying or Removing an NIS Configuration .....                               | 3-20 |
| 3.4     | Managing an NIS Server .....   | 3-20 |
| 3.4.1   | Adding an NIS Slave Server to a Domain .....                                   | 3-20 |
| 3.4.2   | Removing an NIS Slave Server from the Domain .....                             | 3-22 |
| 3.4.3   | Adding a New User to an NIS Domain .....                                       | 3-23 |
| 3.4.4   | Adding a New Group to an NIS Domain .....                                      | 3-25 |
| 3.4.5   | Updating an NIS Map .....  | 3-25 |
| 3.4.6   | Adding an NIS Map to a Domain .....  | 3-26 |
| 3.4.7   | Removing an NIS Map from a Domain .....  | 3-27 |
| 3.4.8   | Modifying the /var/yp/Makefile File .....                                      | 3-28 |
| 3.4.8.1 | Adding an Entry .....  | 3-28 |
| 3.4.8.2 | Deleting an Entry .....  | 3-29 |
| 3.4.9   | Restricting Access to NIS Data .....   | 3-29 |
| 3.5     | Managing an NIS Client .....   | 3-31 |
| 3.5.1   | Changing an NIS Password .....   | 3-31 |
| 3.5.2   | Obtaining NIS Map Information .....  | 3-31 |

## 4 Network File System

|           |   |      |
|-----------|---|------|
| 4.1       | NFS Environment .....                               | 4-1  |
| 4.1.1     | Distributing the hosts Database .....               | 4-1  |
| 4.1.2     | Automatic Mounting Daemons .....                    | 4-2  |
| 4.1.2.1   | Serving Automount and AutoFS Maps with NIS .....    | 4-2  |
| 4.1.2.2   | Local Automount and AutoFS Maps .....               | 4-3  |
| 4.1.2.3   | WebNFS .....  | 4-3  |
| 4.2       | Planning NFS .....                                  | 4-3  |
| 4.2.1     | Server .....  | 4-4  |
| 4.2.1.1   | Exported Directories .....                          | 4-5  |
| 4.2.2     | Client .....  | 4-6  |
| 4.2.2.1   | Imported Directories .....                          | 4-7  |
| 4.3       | Configuring NFS .....                               | 4-8  |
| 4.3.1     | Configuring an NFS Server .....                     | 4-8  |
| 4.3.2     | Configuring an NFS Client .....                     | 4-9  |
| 4.4       | Deconfiguring NFS .....                             | 4-10 |
| 4.5       | Managing an NFS Server .....                        | 4-11 |
| 4.5.1     | Export Guidelines .....                             | 4-11 |
| 4.5.2     | Exporting a File System or Directory .....          | 4-12 |
| 4.5.3     | Halting Export of a Directory or File System .....  | 4-13 |
| 4.5.4     | Enabling Client Superuser Access to Files .....     | 4-14 |
| 4.5.5     | Sending Mail to Superuser (root) Across NFS .....   | 4-15 |
| 4.5.6     | Enabling Port Monitoring .....                      | 4-16 |
| 4.5.7     | Monitoring the NFS Load .....                       | 4-16 |
| 4.6       | Managing an NFS Client .....                        | 4-17 |
| 4.6.1     | Mounting a Remote File System or Directory .....    | 4-18 |
| 4.6.2     | Automatically Mounting a Remote File System .....   | 4-19 |
| 4.6.2.1   | Using Automount to Mount a Remote File System ....  | 4-19 |
| 4.6.2.2   | Using AutoFS to Mount a Remote File System .....    | 4-21 |
| 4.6.2.3   | Specifying automount and autofs mount Arguments ... | 4-23 |
| 4.6.2.4   | Migrating from Automount to AutoFS .....            | 4-25 |
| 4.6.2.4.1 | Recommended Migration Path .....                    | 4-26 |
| 4.6.2.4.2 | High-Availability Migration Path .....              | 4-27 |
| 4.6.3     | Unmounting a Remote File System or Directory .....  | 4-28 |

## 5 UNIX-to-UNIX Copy Program

|       |                                       |     |
|-------|---------------------------------------|-----|
| 5.1   | UUCP Environment .....                | 5-1 |
| 5.2   | Planning UUCP .....                   | 5-2 |
| 5.2.1 | Verifying the Correct Hardware .....  | 5-2 |
| 5.2.2 | Preparing for the Configuration ..... | 5-3 |

|         |   |      |
|---------|---|------|
| 5.2.2.1 | Information for Connections .....                   | 5-3  |
| 5.2.2.2 | Information for Outgoing Systems .....              | 5-6  |
| 5.2.2.3 | Information for Incoming Systems .....              | 5-9  |
| 5.3     | Configuring UUCP .....                              | 5-12 |
| 5.3.1   | Configuring Connections .....                       | 5-12 |
| 5.3.2   | Configuring Outgoing Systems .....                  | 5-13 |
| 5.3.3   | Configuring Incoming Systems .....                  | 5-14 |
| 5.3.4   | Configuring the Poll File .....                     | 5-15 |
| 5.3.5   | Configuring the uucico Daemon .....                 | 5-15 |
| 5.4     | Managing UUCP .....                                 | 5-16 |
| 5.4.1   | Monitoring the File Transfer Queue .....            | 5-17 |
| 5.4.1.1 | Getting Queue Status Manually .....                 | 5-17 |
| 5.4.1.2 | Getting Queue Status Automatically .....            | 5-18 |
| 5.4.1.3 | Guidelines for Checking Queue Status .....          | 5-18 |
| 5.4.2   | Cleaning Up the Spooling Directories .....          | 5-19 |
| 5.4.2.1 | Cleaning Up Directories Manually .....              | 5-19 |
| 5.4.2.2 | Cleaning Up Directories Automatically .....         | 5-20 |
| 5.4.2.3 | Guidelines for Removing Files .....                 | 5-21 |
| 5.4.3   | Viewing Log Files .....                             | 5-21 |
| 5.4.4   | Cleaning Up sulog and cron/log Files .....          | 5-22 |
| 5.4.5   | Limiting the Number of Remote Executions .....      | 5-23 |
| 5.4.6   | Scheduling Work in the Spooling Directory .....     | 5-23 |
| 5.4.6.1 | Starting uusched Manually .....                     | 5-23 |
| 5.4.6.2 | Starting uusched Automatically .....                | 5-23 |
| 5.4.7   | Calling File Transfer Programs (uudemon.hour) ..... | 5-24 |
| 5.4.8   | Polling Remote Systems (uudemon.poll) .....         | 5-25 |

## 6 Network Time Protocol

|       |   |      |
|-------|---|------|
| 6.1   | NTP Environment .....                           | 6-2  |
| 6.2   | Planning NTP .....                              | 6-3  |
| 6.2.1 | Server Information .....                        | 6-4  |
| 6.2.2 | Client Information .....                        | 6-5  |
| 6.3   | Configuring NTP .....                           | 6-6  |
| 6.4   | Enabling the High-Resolution Clock .....        | 6-8  |
| 6.5   | Monitoring Hosts Running the xntpd Daemon ..... | 6-8  |
| 6.6   | Querying Servers Running NTP .....              | 6-10 |

## 7 Mail System

|       |  |     |
|-------|--|-----|
| 7.1   | Mail Environment .....                     | 7-2 |
| 7.1.1 | Directing Outgoing Mail to Servers .....   | 7-5 |
| 7.1.2 | Handling Incoming Mail to the Domain ..... | 7-5 |

|         |  |      |
|---------|--|------|
| 7.1.3   | Delivering Mail to Clients .....                       | 7-5  |
| 7.1.4   | Distributing the aliases File .....                    | 7-6  |
| 7.1.5   | Distributing the passwd File .....                     | 7-6  |
| 7.1.6   | Handling DECnet Mail .....                             | 7-6  |
| 7.2     | Planning Mail .....                                    | 7-8  |
| 7.2.1   | Verifying That Required Protocols Are Installed .....  | 7-8  |
| 7.2.2   | Verifying That Required Services Are Configured .....  | 7-8  |
| 7.2.3   | Preparing for the Configuration .....                  | 7-9  |
| 7.2.3.1 | General System Information .....                       | 7-9  |
| 7.2.3.2 | Protocol Information .....                             | 7-10 |
| 7.3     | Configuring Mail .....                                 | 7-13 |
| 7.3.1   | Configuring a Standalone Mail System .....             | 7-14 |
| 7.3.2   | Configuring a Mail Client .....                        | 7-15 |
| 7.3.3   | Configuring a Mail Server .....                        | 7-16 |
| 7.3.4   | Adding a New Mail Host .....                           | 7-18 |
| 7.4     | Post Office Protocol .....                             | 7-18 |
| 7.4.1   | Installing POP .....                                   | 7-18 |
| 7.4.2   | Migrating to the New POP3 Implementation .....         | 7-19 |
| 7.4.2.1 | Migrating from MH POP3 .....                           | 7-19 |
| 7.4.2.2 | Migrating from Qualcomm POP3 .....                     | 7-20 |
| 7.4.3   | Configuring a POP Mail Account .....                   | 7-20 |
| 7.4.4   | Changing Login Authentication .....                    | 7-21 |
| 7.4.5   | Administrative Tools .....                             | 7-22 |
| 7.4.6   | Directory Structure .....                              | 7-23 |
| 7.5     | Internet Message Access Protocol .....                 | 7-24 |
| 7.5.1   | Installing IMAP .....                                  | 7-24 |
| 7.5.2   | Upgrading IMAP .....                                   | 7-25 |
| 7.5.3   | Configuring IMAP Mail Accounts .....                   | 7-25 |
| 7.5.4   | Migrating Users from UNIX and POP3 Mail .....          | 7-27 |
| 7.5.5   | Administrative Tools .....                             | 7-28 |
| 7.5.6   | Directory Structure .....                              | 7-29 |
| 7.5.7   | Mailbox Namespace .....                                | 7-32 |
| 7.5.8   | Access Control Lists .....                             | 7-33 |
| 7.5.9   | Quotas .....   | 7-35 |
| 7.5.10  | Partitions .....                                       | 7-37 |
| 7.6     | Managing Mail .....                                    | 7-38 |
| 7.6.1   | Monitoring the Mail Queue .....                        | 7-38 |
| 7.6.2   | Archiving the Mail Queue .....                         | 7-39 |
| 7.6.3   | Administering and Distributing Alias Information ..... | 7-40 |
| 7.6.4   | Displaying Mail Statistics .....                       | 7-41 |
| 7.7     | Mail Utilities .....                                   | 7-41 |

## 8 Simple Network Management Protocol

## 9 Solving Network and Network Services Problems

|      |  |      |
|------|--|------|
| 9.1  | Using the Diagnostic Map .....         | 9-1  |
| 9.2  | Getting Started .....                  | 9-2  |
| 9.3  | Solving DNS/BIND Server Problems ..... | 9-4  |
| 9.4  | Solving DNS/BIND Client Problems ..... | 9-5  |
| 9.5  | Solving NIS Server Problems .....      | 9-6  |
| 9.6  | Solving NIS Client Problems .....      | 9-9  |
| 9.7  | Solving NFS Server Problems .....      | 9-12 |
| 9.8  | Solving NFS Client Problems .....      | 9-15 |
| 9.9  | Solving UUCP Problems .....            | 9-17 |
| 9.10 | Solving NTP Problems .....             | 9-20 |
| 9.11 | Solving sendmail Problems .....        | 9-22 |
| 9.12 | Solving POP and IMAP Problems .....    | 9-24 |

## 10 Using the Problem Solving Tools

|      |  |      |
|------|--|------|
| 10.1 | Testing a UUCP Remote Connection .....         | 10-1 |
| 10.2 | Monitoring a UUCP File Transfer .....          | 10-3 |
| 10.3 | Viewing the Error Log File .....               | 10-3 |
| 10.4 | Viewing the syslogd Daemon Message Files ..... | 10-4 |

## 11 Testing DNS Servers

|       |   |       |
|-------|---|-------|
| 11.1  | Glossary .....                                      | 11-1  |
| 11.2  | DNS Server Testing Worksheet .....                  | 11-2  |
| 11.3  | Starting the DNS Server Test .....                  | 11-3  |
| 11.4  | Determining the Server Type .....                   | 11-5  |
| 11.5  | Finding the Target Domain Information .....         | 11-8  |
| 11.6  | Testing the Forwarders .....                        | 11-10 |
| 11.7  | Testing Slave Servers .....                         | 11-11 |
| 11.8  | Testing Master Servers .....                        | 11-15 |
| 11.9  | Tracing Information from the Root Name Server ..... | 11-18 |
| 11.10 | Resolving Target Data .....                         | 11-20 |
| 11.11 | Finding the First Nonexistent Domain .....          | 11-22 |

## 12 Reporting Network Problems

|      |   |      |
|------|---|------|
| 12.1 | Gathering General Information .....               | 12-1 |
| 12.2 | Gathering Hardware Architecture Information ..... | 12-2 |



|  |   |      |
|--|---|------|
| 12.3                                       | Gathering Software Architecture Information ..... | 12-2 |
| <b>A Writing Automount and AutoFS Maps</b> |   |      |
| A.1  | Substitution and Pattern Matching .....           | A-5  |
| A.2  | Environment Variables .....                       | A-6  |
| A.3  | Mounting File Systems .....                       | A-7  |
| A.3.1                                      | Multiple Mounts .....                             | A-7  |
| A.3.2                                      | Shared Mounts .....                               | A-8  |
| A.3.3                                      | Replicated File Systems .....                     | A-9  |
| <b>B NIS ypservers Update Scripts</b>      |   |      |
| B.1  | Add Slave Server Script .....                     | B-1  |
| B.2  | Remove Slave Server Script .....                  | B-2  |
| <b>C NFS Error Messages</b>                |   |      |
| C.1  | Server Error Messages .....                       | C-1  |
| C.2  | Client Error Messages .....                       | C-2  |
| C.2.1                                      | Remote Mount Error Messages .....                 | C-3  |
| C.2.2                                      | Automount Error Messages .....                    | C-6  |
| C.2.3                                      | AutoFS Error Messages .....                       | C-10 |
| C.2.3.1                                    | autofs Messages .....                             | C-10 |
| C.2.3.2                                    | autofsmount Messages .....                        | C-12 |
| C.2.4                                      | Console Error Messages .....                      | C-14 |
| <b>D uucp Messages</b>                     |   |      |
| D.1  | Status and Log File Messages .....                | D-1  |
| D.2  | tip Error Messages .....                          | D-8  |
| <b>E sendmail Error Messages</b>           |   |      |
| <b>F Host Resources MIB Implementation</b> |   |      |
| F.1  | Tru64 UNIX Implementation Summary .....           | F-1  |
| F.2  | System Group .....                                | F-1  |
| F.3  | Storage Group .....                               | F-2  |
| F.4  | Device Tables .....                               | F-3  |
| F.5  | File System Table .....                           | F-8  |
| F.6  | Running Software Tables .....                     | F-9  |

## G Format of DNS Data File Entries

|        |  |      |
|--------|--|------|
| G.1    | Format of DNS Resource Records .....   | G-1  |
| G.2    | Description of Data File Entries ..... | G-3  |
| G.2.1  | Include Entry .....                    | G-3  |
| G.2.2  | Origin Entry .....                     | G-3  |
| G.2.3  | TTL Entry .....                        | G-4  |
| G.2.4  | Address Entry .....                    | G-4  |
| G.2.5  | Canonical Name Entry .....             | G-5  |
| G.2.6  | Host Information Entry .....           | G-6  |
| G.2.7  | Mailbox Entry .....                    | G-6  |
| G.2.8  | Mail Group Entry .....                 | G-7  |
| G.2.9  | Mailbox Information Entry .....        | G-7  |
| G.2.10 | Mail Rename Entry .....                | G-8  |
| G.2.11 | Mail Exchanger Entry .....             | G-9  |
| G.2.12 | Name Server Entry .....                | G-10 |
| G.2.13 | Domain Name Pointer Entry .....        | G-10 |
| G.2.14 | Start of Authority Entry .....         | G-11 |
| G.2.15 | Well Known Services Entry .....        | G-12 |

## Index

### Examples

|     |   |      |
|-----|---|------|
| 2-1 | Sample named.keys File for Authentication .....   | 2-26 |
| 2-2 | Sample Master Server named.conf File for Authentication ....                            | 2-27 |
| 2-3 | Sample Slave Server named.conf File for Authentication .....                            | 2-28 |
| A-1 | Multiple Mounts in a Direct Map .....   | A-2  |
| A-2 | Multiple Mounts and Shared Mounts in a Direct Map .....                                 | A-3  |
| A-3 | Multiple Mounts, Shared Mounts, and Replicated File<br>Systems in a Direct Map .....    | A-3  |
| A-4 | Simple Indirect Map .....   | A-3  |
| A-5 | Multiple Mounts in an Indirect Map .....  | A-4  |
| A-6 | Multiple Mounts and Shared Mounts in an Indirect Map .....                              | A-4  |
| A-7 | Multiple Mounts, Shared Mounts, and Replicated File<br>Systems in an Indirect Map ..... | A-4  |

### Figures

|     |                            |     |
|-----|----------------------------|-----|
| 1-1 | SysMan Menu .....          | 1-3 |
| 1-2 | Quick Setup .....          | 1-4 |
| 1-3 | Network Setup Wizard ..... | 1-6 |

|      |  |      |
|------|--|------|
| 1-4  | Compaq Management Agents .....                   | 1-8  |
| 2-1  | Sample Small DNS Configuration .....             | 2-4  |
| 2-2  | Sample Large DNS Configuration .....             | 2-5  |
| 2-3  | DNS Setup Worksheet .....                        | 2-7  |
| 3-1  | NIS Configuration .....                          | 3-2  |
| 3-2  | NIS Setup Worksheet .....                        | 3-4  |
| 4-1  | NFS Setup Worksheet .....                        | 4-4  |
| 5-1  | Sample Simple UUCP Configuration .....           | 5-2  |
| 5-2  | Sample UUCP Over TCP/IP Configuration .....      | 5-2  |
| 5-3  | UUCP Setup Worksheet .....                       | 5-4  |
| 5-4  | UUCP Outgoing Systems Worksheet .....            | 5-7  |
| 5-5  | UUCP Incoming Systems Worksheet .....            | 5-9  |
| 6-1  | Sample NTP Configuration (Local Clock) .....     | 6-2  |
| 6-2  | Sample NTP Configuration (Internet Source) ..... | 6-3  |
| 6-3  | NTP Setup Worksheet .....                        | 6-4  |
| 7-1  | Sample Mail Standalone Configuration .....       | 7-3  |
| 7-2  | Sample Mail Client/Server Configuration .....    | 7-4  |
| 7-3  | Basic Mail Setup Worksheet .....                 | 7-9  |
| 7-4  | Mail Protocol Worksheet .....                    | 7-11 |
| 7-5  | POP Directory Structure .....                    | 7-23 |
| 7-6  | IMAP Directory Structure .....                   | 7-29 |
| 7-7  | Quota Roots .....                                | 7-36 |
| 11-1 | DNS Server Testing Worksheet .....               | 11-3 |
| A-1  | Sample automount Maps .....                      | A-2  |

## Tables

|     |  |      |
|-----|--|------|
| 3-1 | NIS Map Information Commands .....     | 3-31 |
| 5-1 | Options for uucpsetup Command .....    | 5-12 |
| 6-1 | Options to the ntpq Command .....      | 6-9  |
| 6-2 | Options to the xntpd Command .....     | 6-10 |
| 7-1 | POP3 Files and Directories .....       | 7-23 |
| 7-2 | Configuration Directory Contents ..... | 7-30 |
| 7-3 | Mailbox Directory Contents .....       | 7-32 |
| 9-1 | Problem Solving Starting Points .....  | 9-2  |
| D-1 | ASSERT Error Messages .....            | D-2  |



---

## About This Manual

This manual describes how to configure and manage network applications and services, and solve network problems that might arise on systems running the Tru64™ UNIX operating system software.

This manual assumes that the operating system software and the appropriate networking subsets are installed.

### Audience

This manual is intended for system and network administrators responsible for configuring and managing network services. Administrators are expected to have knowledge of operating system concepts, commands, and configuration. It is also helpful to have knowledge of Transmission Control Protocol/Internet Protocol (TCP/IP) networking concepts and network configuration; this manual is not a TCP/IP networking tutorial.

### New and Changed Features

The *Network Administration* manual has been reorganized into two volumes: *Network Administration: Connections* and *Network Administration: Services*.

This volume, *Network Administration: Services*, contains all of the information regarding network services and applications that previously existed in the *Network Administration* manual, plus a new section on how to migrate to the AutoFS daemon from the Automount daemon (which is being retired in a future release).

### Organization

The *Network Administration: Services* manual is divided into several chapters, each of which contains information about configuring a different service or application. The manual also includes appendixes that contain supplemental information.

The following list describes the content in more detail:

|                   |   |
|-------------------|---|
| <i>Chapter 1</i>  | Describes network administration and the components that this manual covers.  |
| <i>Chapter 2</i>  | Describes the tasks to administer the Domain Name System (DNS)  |
| <i>Chapter 3</i>  | Describes the tasks to administer the Network Information Service (NIS)   |
| <i>Chapter 4</i>  | Describes the tasks to administer the Network File System (NFS)   |
| <i>Chapter 5</i>  | Describes the tasks to administer the UNIX-to-UNIX Copy Program (UUCP)  |
| <i>Chapter 6</i>  | Describes the tasks to administer the Network Time Protocol (NTP)   |
| <i>Chapter 7</i>  | Describes the tasks to administer the mail environment  |
| <i>Chapter 8</i>  | Describes the Simple Network Management Protocol (SNMP)   |
| <i>Chapter 9</i>  | Describes how to diagnose network and network service problems  |
| <i>Chapter 10</i> | Describes the various diagnostic tools available to help solve problems   |
| <i>Chapter 11</i> | Describes how to test DNS servers and resolve DNS server problems   |
| <i>Chapter 12</i> | Describes how to report problems to Compaq and the information you need to provide                                  |
| <i>Appendix A</i> | Describes how to write Automount and AutoFS maps  |
| <i>Appendix B</i> | Contains two scripts you can copy for adding NIS slave servers to and removing NIS slave servers from an NIS domain |
| <i>Appendix C</i> | Contains NFS error messages and describes possible solutions  |
| <i>Appendix D</i> | Contains uucp error messages and describes possible solutions   |
| <i>Appendix E</i> | Contains sendmail error messages and describes possible solutions   |
| <i>Appendix F</i> | Describes the Tru64 UNIX host MIB implementation, including sample data   |
| <i>Appendix G</i> | Describes the format of DNS file entries  |

## Related Documents

For more information about Tru64 UNIX networking and communications, see the following books:

- *Network Administration: Connections*

Provides information about the network connections over which the networking services and applications covered in this manual run. Explains how to configure and manage the following connections and transports:

- Basic network connections, including Ethernet, Token Ring, and Fiber Distributed Data Interface (FDDI) interfaces, automatic network adapter failover (NetRAIN), and network daemons
- Internet Protocol Version 6 (IPv6)
- Asynchronous Transfer Mode (ATM)
- Dynamic Host Configuration Protocol (DHCP)
- Point-to-point connections, including Serial Line Internet Protocol (SLIP) and Point-to-Point Protocol (PPP)
- Local Area Transport (LAT)
- *BIND Configuration File Guide*

Provides information about how to manually create and edit the named.conf configuration file on systems that use the DNS/BIND for address resolution. This document is available in HTML format on the Tru64 UNIX Documentation CD-ROM.
- *Command and Shell User's Guide*

Introduces users to the basic uses of commands and shells in the operating system.
- *Sendmail Installation and Operation Guide*

Provides additional information about using the sendmail command. This document is available in PDF format on the Tru64 UNIX Documentation CD-ROM.
- The *sendmail* guide by O'Reilly & Associates

Provides additional information about using the sendmail command.
- Request for Comments (RFC)

Many sections of this book refer to RFCs (for example, RFC 1577) for more information about certain networking topics. These documents publicize Internet Standards, new research concepts, and status memos about the internet. You can access the full range of RFC documents and more information about the Internet Engineering Task Force (IETF) at the following URL:

**<http://www.ietf.org>**
- Best Practices

Compaq Tru64 UNIX Best Practices describe some networking concepts and tasks, as well as other topics. You can find these documents on the Tru64 UNIX Publications Home Page at the following URL:

**<http://www.tru64unix.compaq.com/docs/>**

### **Icons on Tru64 UNIX Printed Manuals**

The printed version of the Tru64 UNIX documentation uses letter icons on the spines of the manuals to help specific audiences quickly find the manuals that meet their needs. (You can order the printed documentation from Compaq.) The following list describes this convention:

- G     Manuals for general users
- S     Manuals for system and network administrators
- P     Manuals for programmers
- R     Manuals for reference page users

Some manuals in the documentation help meet the needs of several audiences. For example, the information in some system manuals is also used by programmers. Keep this in mind when searching for information on specific topics.

The *Documentation Overview* provides information on all of the manuals in the Tru64 UNIX documentation set.

## **Reader's Comments**

Compaq welcomes any comments and suggestions you have on this and other Tru64 UNIX manuals.

You can send your comments in the following ways:

- Fax: 603-884-0120 Attn: UBPG Publications, ZKO3-3/Y32
- Internet electronic mail: [readers\\_comment@zk3.dec.com](mailto:readers_comment@zk3.dec.com)

A Reader's Comment form is located on your system in the following location:

```
/usr/doc/readers_comment.txt
```

Please include the following information along with your comments:

- The full title of the manual and the order number. (The order number appears on the title page of printed and PDF versions of a manual.)
- The section numbers and page numbers of the information on which you are commenting.
- The version of Tru64 UNIX that you are using.



- If known, the type of processor that is running the Tru64 UNIX software.

The Tru64 UNIX Publications group cannot respond to system problems or technical support inquiries. Please address technical questions to your local system vendor or to the appropriate Compaq technical support office. Information provided with the software media explains how to send problem reports to Compaq.

## Conventions

This document uses the following typographic conventions:

|  |   |
|--|---|
| %  |   |
| \$   | A percent sign represents the C shell system prompt.<br>A dollar sign represents the system prompt for the Bourne, Korn, and POSIX shells.  |
| #  | A number sign represents the superuser prompt.  |
| % <b>cat</b>   | Boldface type in interactive examples indicates typed user input.   |
| <i>file</i>  | Italic (slanted) type indicates variable values, placeholders, and function argument names.   |
| [   ]  |   |
| {   }  | In syntax definitions, brackets indicate items that are optional and braces indicate items that are required. Vertical bars separating items inside brackets or braces indicate that you choose one item from among those listed.           |
| ...  | In syntax definitions, a horizontal ellipsis indicates that the preceding item can be repeated one or more times.   |
| cat(1)   | A cross-reference to a reference page includes the appropriate section number in parentheses. For example, <code>cat(1)</code> indicates that you can find information on the <code>cat</code> command in Section 1 of the reference pages. |
| <span style="border: 1px solid black; padding: 2px;">Return</span> | In an example, a key name enclosed in a box indicates that you press that key.  |

Ctrl/x

This symbol indicates that you hold down the first named key while pressing the key or mouse button that follows the slash. In examples, this key combination is enclosed in a box (for example, Ctrl/C).

---

## Overview to Network Administration

Network administration comprises those tasks that deal with setting up and configuring network interfaces, software, and daemons, and those tasks that deal with the day-to-day management of those interfaces, software, and daemons, including solving problems that might arise.

This chapter describes:

- How to use this manual in the day-to-day management of your network (Section 1.1)
- Several utilities and methods you can use to administer network components (Section 1.2)

### 1.1 Introduction to *Network Administration: Services*

This manual describes the administration of the following:

- Domain Name System (DNS) (Chapter 2)
- Network Information Service (NIS), formerly named Yellow Pages (Chapter 3)
- Network File System (NFS) (Chapter 4)
- UNIX-to-UNIX Copy Program (UUCP) (Chapter 5)
- Network Time Protocol (NTP) (Chapter 6)
- Mail system, including sendmail, Post Office Protocol (POP) and Internet Message Access Protocol (IMAP) (Chapter 7)
- Simple Network Management Protocol (SNMP) (Chapter 8)

Information regarding network connections and transports is maintained in a separate volume, *Network Administration: Connections*.

Day-to-day management varies with each network service, as each service provides different capabilities. Typically, management involves making small changes and adjustments, such as adding NIS user accounts, mounting remote file systems or directories, obtaining status information, and setting up automatic maintenance scripts. Chapters 2–8 of this manual describe specific tasks, presenting the generic steps required to perform the tasks followed by examples and additional information.

In addition to the day-to-day management of network services and applications, this manual contains information to help you solve problems that might occur. Problem solving is handled differently from administration because it is not something that you have to do every day.

Unlike the administration chapters, problem-solving chapters are structured according to specific problems. Within each problem section are the steps to resolve the problem.

The key to successful problem solving is in isolating the source of the problem. Frequently, complex networks and interactions between network services make this difficult to do. If you encounter a problem, whether by error message or event (for example, slow response), do the following:

1. Check your system, its network interface, and connections to the network.
2. Check the network and your system's ability to reach a remote system.

Most problems can be solved after you perform these two steps. If not, go to the appropriate problem-solving section and follow the steps.

## 1.2 Administrative Methods

The following sections provide a brief overview of the methods for administering networking components in the operating system. As explained in Section 1.2.4, it is best to not to edit configuration files manually for network configuration tasks. Instead, it is highly recommended that you use the SysMan Menu utility whenever possible.

### 1.2.1 SysMan Menu

The SysMan Menu utility enables you to administer your system locally via a graphical user interface or command-line interface, or even remotely via the World Wide Web. It provides a single, hierarchical menu interface that allows you to quickly find and invoke suitlets (integrated utilities) to perform the most common management tasks.

In this manual, wherever the SysMan Menu utility is mentioned in relation to configuration tasks, it is presumed that you know how to invoke it. To invoke the SysMan Menu utility from CDE, do the following:

1. Select the Application Manager icon on the CDE front panel.
2. Select the System\_Admin application group icon.
3. Select the SysMan Menu. The SysMan Menu is displayed and lists various system management tasks.

If you are not using CDE, you can invoke the SysMan Menu in one of the following ways:

```
# /usr/sbin/sysman
```

From a character-cell terminal or terminal window, for curses mode, enter:

```
# sysman -ui cui
```

After you invoke the SysMan Menu, double-click on menu items to select them. Or, on a system without graphics capabilities, use the arrow keys and the Enter key to select items. Many menu items will expand to offer more choices. Navigate the menu until you find the desired suitlet.

In Figure 1–1, the user selects the Basic Network Services menu item, which expands to reveal the suitlets for configuring network adapters and other basic networking components.

**Figure 1–1: SysMan Menu**

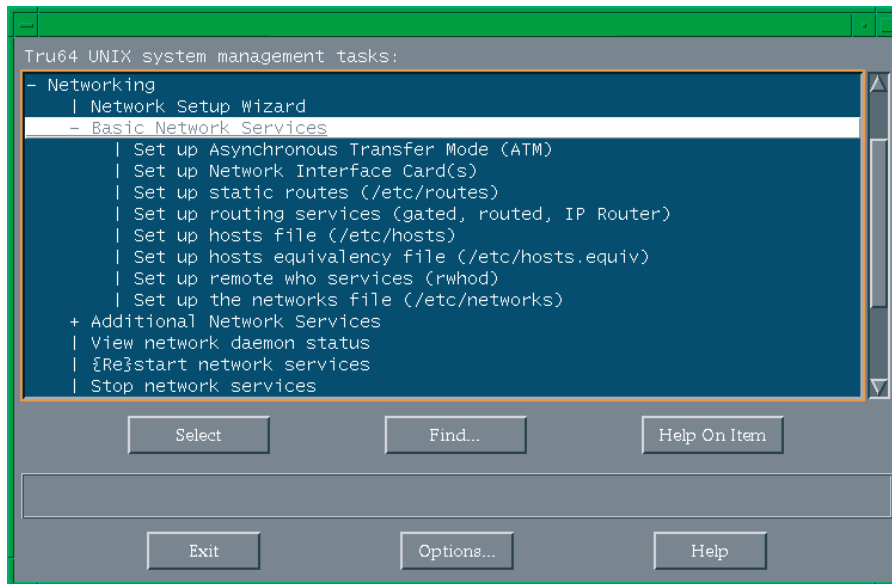

To exit the SysMan Menu, select Exit. On a system without graphics capabilities, use the Tab key to move the cursor to Exit, then press the Enter key.

For more information about the SysMan Menu, see *System Administration*, `sysman(8)`, and the online help.

### 1.2.1.1 Quick Setup

The SysMan Menu includes a Quick Setup utility that you can use to configure basic components and services on a client system. The Quick Setup utility starts automatically when the system boots following a full installation of the operating system. However, to use the utility at any time, invoke the SysMan Menu and select General Tasks→Quick Setup, or enter the following command on a command line:

```
# /usr/bin/sysman quicksetup
```

The Quick Setup utility, as shown in Figure 1–2, is displayed.

**Figure 1–2: Quick Setup**

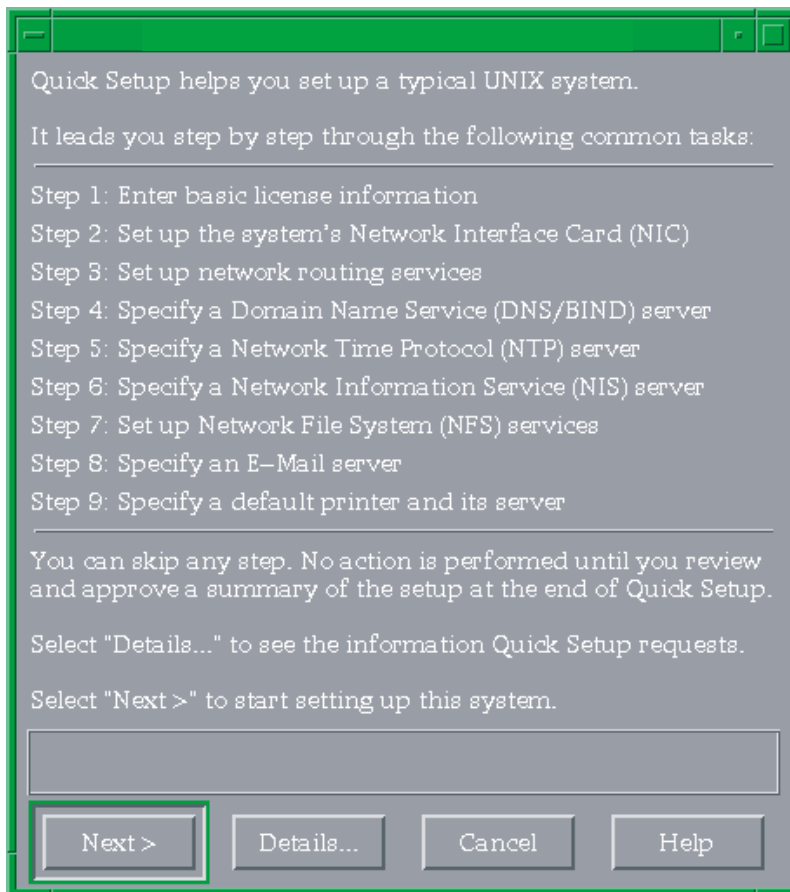

The utility leads you through the displayed configuration steps, many of which prepare your system for operation on a network. Enter the information for each step of the process and select Next to display the subsequent step. You can move back and forth through the steps if you

have missed something. No information is saved until you confirm the configuration by selecting Finish in the last step.

If necessary, you can configure additional components or modify your configuration after you use the utility. For more information about the Quick Setup utility, see the online help.

### 1.2.1.2 Network Setup Wizard

The SysMan Menu also includes a Network Setup Wizard utility that you can use to configure network components on your system. You can invoke the configuration suitlets through the SysMan Menu to configure basic network services on an individual basis, or you can use the Network Setup Wizard, which leads you step-by-step through the setup process for all of the basic network services.

To use the Network Setup Wizard, invoke the SysMan Menu and select Networking→Network Setup Wizard, or enter the following command on a command line:

```
# /usr/bin/sysman net_wizard
```

The Network Setup Wizard utility, as shown in Figure 1–3, is displayed.

**Figure 1–3: Network Setup Wizard**

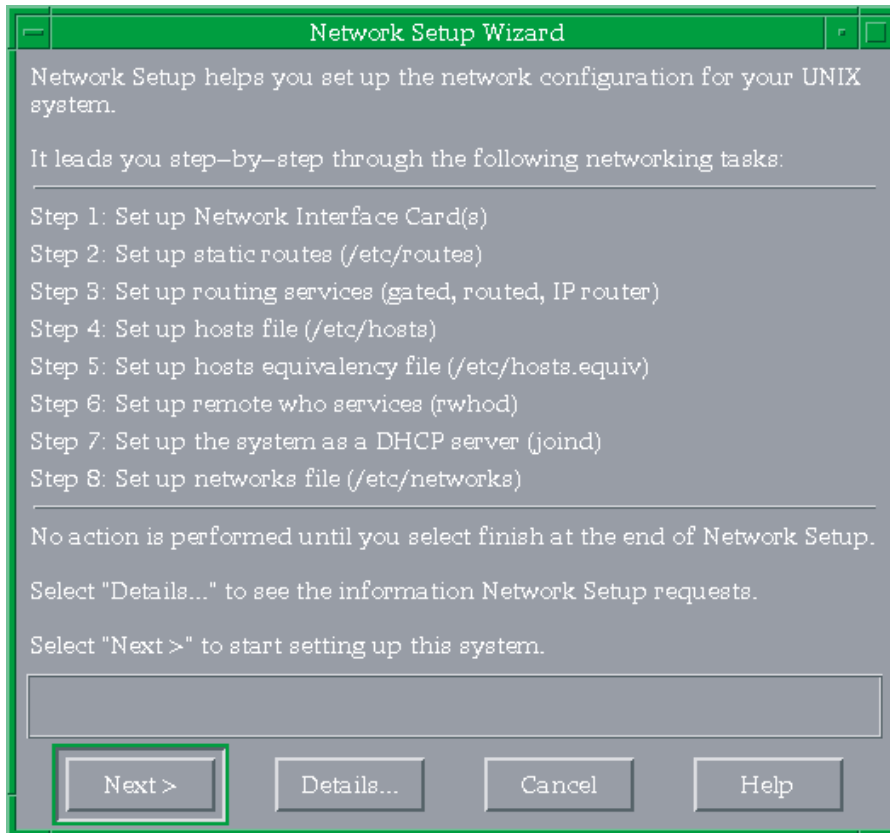

The utility leads you through the displayed configuration steps. Enter the information for each step of the process and select Next to display the subsequent step. You can move back and forth through the steps if you have missed something. No information is saved until you confirm the configuration by selecting Finish in the last step.

If necessary, you can configure additional components or modify your configuration after you use the utility. For more information about the Network Setup Wizard utility, see the online help.

### 1.2.1.3 Command-Line Integration

The SysMan Menu allows you to access and manipulate many configuration options directly from the command line. This feature is particularly useful for administrators who want to create site-specific shell scripts to perform configuration tasks.



To use the command-line interface, invoke the `sysman -cli` command. For the command's arguments, specify the component and group on which you want to operate and the action you want to perform.

For example, suppose you want to list all of the entries in the `/etc/hosts` file. You would enter the following command:

```
# sysman -cli -list val -comp networkedSystems \  
-group hostMappings
```

You could also add a host to the file by entering this command:

```
# sysman -cli -add row -comp networkedSystems \  
-group hostMappings -data "{queen} \  
{DNS server} {18.240.32.40} {queen.abc.xyz.com}"
```

You can even change an existing value in the file, like an IP address, as follows:

```
# sysman -cli -set val -comp networkedSystems \  
-group hostMappings -attr networkAddress="18.240.32.45" \  
-key1 queen.abc.xyz.com -key2 18.240.32.40
```

For more information about this command line interface for the SysMan Menu, see *System Administration* and `sysman_cli(8)`.

## 1.2.2 Compaq Insight Manager

Compaq Insight Manager is a Web-based system management utility. It consists of two different components: the Management Agents, which run on many different operating systems (including Tru64 UNIX), and the Management Console, which runs exclusively on Microsoft Windows NT.

By enabling the Compaq Management Agents on your Tru64 UNIX systems, you can provide a conduit for communication between these systems and the World Wide Web. Once enabled, this conduit allows you to access information about the configuration of your systems and their peripherals from a Web browser on any system. In some Java-enabled Web browsers, you can also invoke the SysMan Menu through this interface to manage these systems.

Figure 1-4 shows an example of using the Management Agents to obtain statistics for an Ethernet network adapter.

**Figure 1–4: Compaq Management Agents**

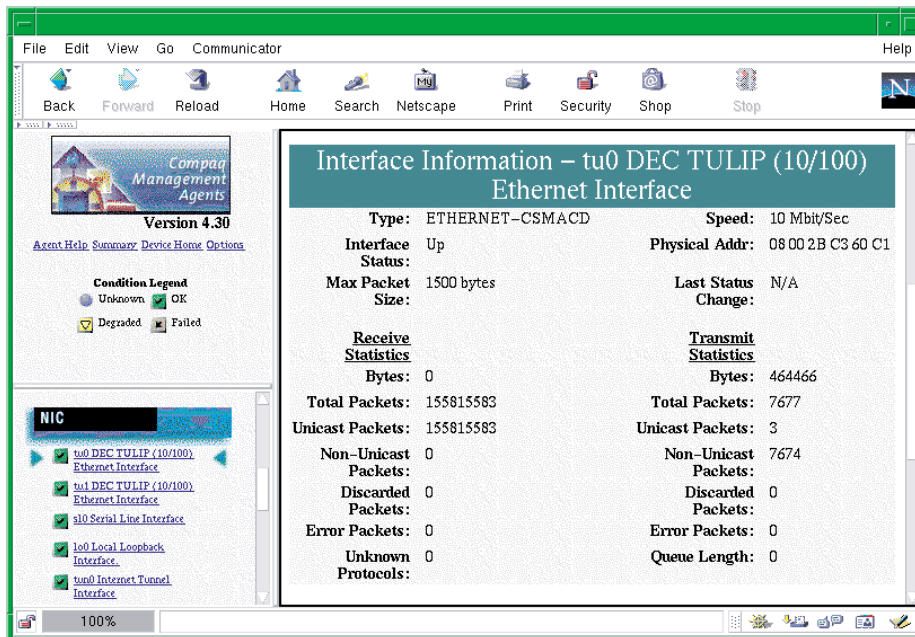

Using the Compaq Insight Manager XE Management Console, you can view and manage your systems as well as many standalone devices (such as printers, routers, and more) on your network. The Management Console is especially useful for managing heterogeneous environments, as it can communicate with the Management Agents for all of the supported operating systems and environments.

For more information about Compaq Insight Manager, see `insight_manager(5)` and *System Administration*.

### 1.2.3 Other Interfaces

The operating system includes alternative system administration applications, some that require graphics capabilities and others that allow you to configure your system from the command line. This manual mentions these optional utilities, when available, in relation to specific configuration tasks.

See Chapter 2 of *System Administration* for a comprehensive list of the utilities that are available. See the reference pages and online help for more information about each utility.

## 1.2.4 Manually Editing Configuration Files

Some sections of this manual describe the system files that are updated or modified when you perform an administrative task. Experienced UNIX administrators might prefer to administer their systems by manually editing these files, as opposed to invoking the documented utility; however, it is strongly recommended that you use the appropriate utilities to update the system files so that the structure of these files is preserved.

Important considerations are:

- Context-Dependent Symbolic Links (CDSLs)  
Many system files now exist as special symbolic links (CDSLs) created to facilitate TruCluster Server clusters. The links are transparent to most users, but if the links are broken, the system cannot join a cluster in the future without recreating them. This manual mentions a few of the CDSLs, especially when you must create them manually. See the `hier(5)` reference page for a complete list of the CDSLs in the file system. See *System Administration* for more information.
- Binary databases, configuration definitions  
Many system components write data to both text and binary files, and their administrative utilities often recreate the binary files. Other system information is often preserved so that when you update your system, it can be recovered and reused, saving you time and effort.
- Latent support for clusters  
Individual systems are capable of joining TruCluster Server clusters, and many system files have been modified to provide latent support for clusters. For example, the `rc.config` file now has two related files, `rc.config.common` and `rc.config.site`, which can store run-time configuration variables. Altering these files with the `rcmgr` utility ensures the integrity and consistency of these files.
- Update installation  
During the update installation process, changed information is merged into existing system files. The `.new.*` and `.proto.*` files might be important in this process. Refer to the *Installation Guide* for more information.

In many cases, the SysMan Menu utility is the best alternative to manually editing system files, thus it is the utility that is most frequently covered in this manual.

## 1.2.5 Installation and Configuration Cloning

The operating system includes two features, Installation Cloning and Configuration Cloning, that allow you to minimize the amount of manual

intervention that is necessary to install and configure systems. These features are particularly useful if you need to set up many identical systems in the same way, because they allow you to capture the configuration of a working system in configuration description files (CDFs) and use those files to install and configure subsequent systems.

See *Installation Guide — Advanced Topics* for more information.

# 2

---

## Domain Name System

The Domain Name System (DNS) is a mechanism for resolving unknown host names and Internet Protocol (IP) addresses that originate from sites on your company's intranet or the Internet. A database lookup service that is part of the DNS daemon searches for the unknown hosts in local and remote `hosts` databases, which are distributed across the network by the DNS.

The implementation of DNS in Tru64 UNIX is based on Version 8.2.2 of the Berkeley Internet Name Domain (BIND) service, which is maintained by the Internet Software Consortium.

This chapter describes:

- The DNS environment (Section 2.1)
- A mechanism for remotely updating the DNS database from new DNS clients (Section 2.2)
- A mechanism for authenticating updates to the DNS database (Section 2.3)
- How to plan for your DNS configuration (Section 2.4)
- How to configure DNS servers and clients (Section 2.5)
- How to configure authentication on DNS servers (Section 2.6)
- How to deconfigure DNS servers and clients (Section 2.7)
- How to manage DNS servers and clients (Section 2.8)

For introductory information on DNS, see `bind_intro(7)`. For additional information about BIND service, see Appendix G and the *BIND Configuration File Guide* (provided in HTML format on the Tru64 UNIX Documentation CD-ROM). You can also visit the Internet Software Consortium website at the following URL:

**<http://www.isc.org>**

---

### Note

The BIND server daemon, `/usr/sbin/named`, supports AAAA (IPv6 address entry) lookups over IPv4 (AF\_INET) connections only. The resolver and server have not been ported to IPv6, but IPv6 applications can make `getaddrinfo` and `getnameinfo`

calls to retrieve the AAAA records. See the *Network Programmer's Guide* for information on using these routines.

---

For troubleshooting information, see Section 9.3 and Chapter 11 for servers and Section 9.4 for clients.

## 2.1 DNS Environment

In the DNS environment, systems can have the following roles:

- Master server — A system that is an authoritative source for information about a zone or zones and that maintains the master copy of the DNS database for the zone or zones.

The master server runs the `named` daemon, answers requests from clients and other servers, caches information, and distributes the databases to slave servers.

- Slave server — A system that is an authoritative source for information about a zone or zones, but does not maintain the master copy of the DNS database for the zone or zones. Instead, a slave server loads its database files from the master server when the master server indicates that the files have been updated.

A slave server runs the `named` daemon, provides backup for the master server, answers requests from clients and other servers, and caches information.

- Stub server — A master server that delegates authority for a specified subzone to a server local to the subzone.

The stub server does not retain information in its configuration files about the machines in the specified subzone. Instead of searching the master DNS database, it queries the local server for information about machines in the subzone.

Typically, stub service is implemented so that the administrator of a subzone can change the configuration of the subzone without affecting the configuration file on the master server.

- Caching-only server — A system that is not authoritative for any zones. This system runs the `named` daemon and responds to queries from other servers and clients by querying other servers for the information and caching the information it receives. Information is stored until the data expires.

Typically, a caching-only server has direct access to the Internet and it answers queries exclusively about sites on the Internet.

- Forward-only server — A system that might be an authoritative source for information about a zone or zones, but is restricted as to how it obtains information about zones for which it is not authoritative.

This system runs the `named` daemon and responds to queries from other servers and clients with information from its authoritative data and cache data. If the information is not present, the system forwards queries to a list of systems specified as forwarders in its `named.conf` file. The queries are forwarded to each forwarder system until the list is exhausted or the query is satisfied. Forward-only servers store the information they receive until the data expires.

Typically, a forward-only server has restricted access to an intranet or the Internet. By providing a list of specific forwarders to contact, an administrator can prevent a forward-only server from attempting to contact servers that it cannot access.

- Client — A system that queries a server for host name and address information, interprets responses, and passes information to requesting applications. The client is also called a resolver. A client does not run the `named` daemon.

---

**Note**

---

Documentation for BIND prior to Version 8.1.1 referred to the master server as a primary server and the slave server as a secondary server. Though the terminology has changed, master and slave servers are still referred to as having primary and secondary authority, respectively, for zones.

---

DNS runs on each system in your network. You must decide what role each system will play in the DNS environment that you create. For each domain, select one host to be the master server; there can be only one master server for each domain. Select one or more hosts to be slave, stub, and caching-only servers. Configure the rest of the hosts as DNS clients.

Figure 2–1 shows a domain in which there are two servers, one on each subnet, and multiple clients. Server A, the master server, has primary authority for the zone and maintains the database files for the zone. Server B, the slave server, has secondary authority for the zone; it obtains a copy of the zone database from Server A and responds to queries from clients.

**Figure 2–1: Sample Small DNS Configuration**

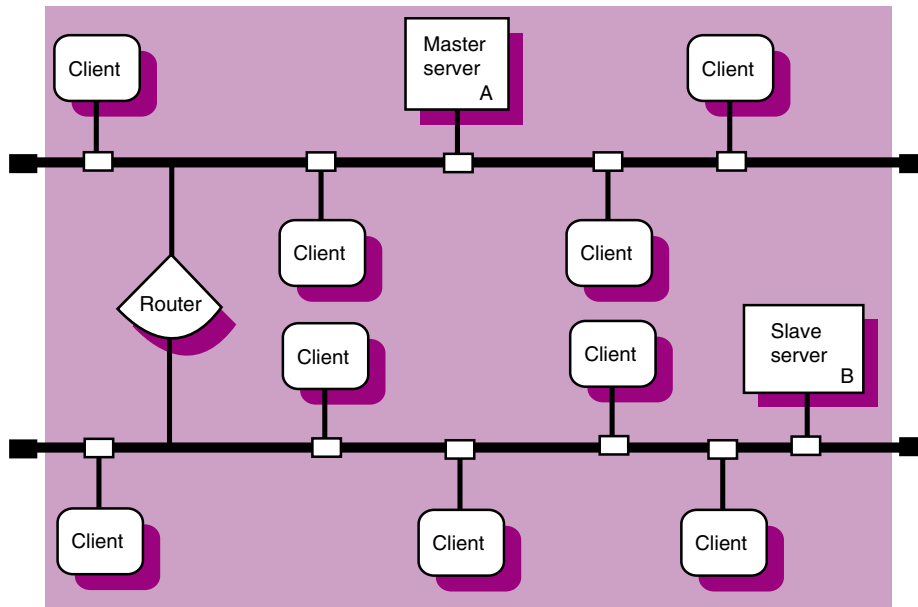

ZK-1162U-AI

Figure 2–2 shows a domain in which there are three zones: `mktg.corp.com`, `eng.corp.com`, and `acct.corp.com`. Server B is the master server for the `mktg.corp.com` zone and a slave server for the other two zones. It has primary authority for `mktg.corp.com` and secondary authority for each of the other two zones. Server C has primary authority for the `eng.corp.com` zone and secondary authority for each of the other two zones. Server D has primary authority for the `acct.corp.com` zone and secondary authority for each of the other two zones. Server A is both a router and a caching-only server. As a caching-only server, it caches information it receives from queries out of the parent domain.

In the same example, if the three zones were located in three different cities or countries, you could configure Server A at `mktg.corp.com` as a stub server for the other two remote zones. That way, all of the resource records for the remote sites would reside on servers (Server C and Server D) local to the `eng.corp.com` and `acct.corp.com` domains. The master server, Server A, would retain only the resource records for the name server that is local to each subdomain. Server A would query Server C and Server D for information about the machines in the `eng.corp.com` and `acct.corp.com` domains instead of searching its own master DNS database.



Figure 2–2: Sample Large DNS Configuration

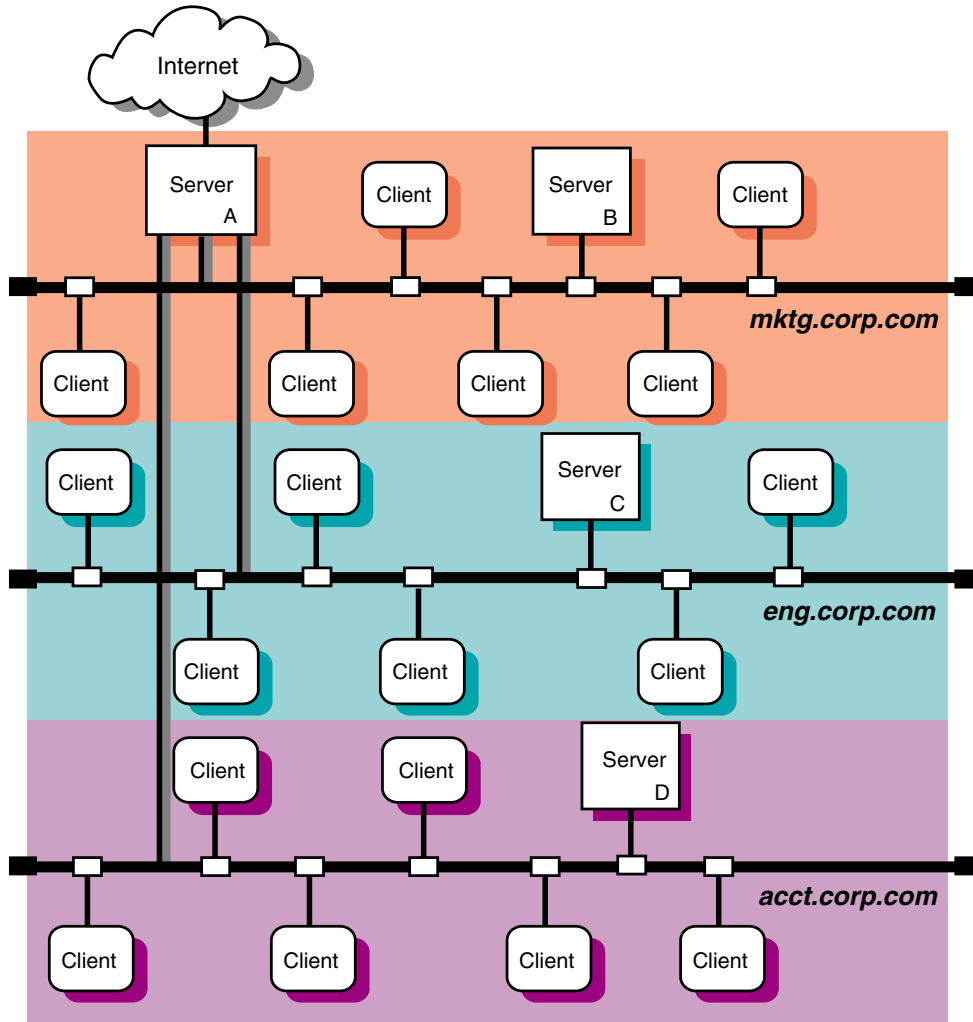

ZK-1161U-AI

## 2.2 Dynamic Updates

Typically, whenever you connect a new host to a network, you need to rebuild the DNS database as explained in Section 2.8.2. If you do not update the DNS database, other computers on the network will not be able to resolve the new host's address.

However, some clients, particularly Tru64 UNIX systems that are configured for IPv6 networks and Microsoft Windows systems, can automatically update the DNS database for you. These clients support dynamic updates,

which allow hosts to inform the DNS master server that they are being added to or removed from the network. The clients specify their IP address and host name, and the `named` daemon automatically makes the appropriate changes in the DNS master data file. There is no need for intervention by the administrator of the master server, which saves the administrator a lot of effort in larger networks.

See Section 2.5.1.2 for information about configuring dynamic updates on the DNS master server.

## 2.3 Authentication of Dynamic Updates and Zone Transfers

DNS servers can provide cryptographic authentication of the data they receive from other systems. Authentication reduces the possibility that a rogue system can assume the identity of another system and send bogus DNS data file updates to servers.

The operating system provides support for symmetric cryptography, where two or more systems share a single private key for DNS authentication. A system that sends a DNS update to another system can use this key to generate a unique digital signature that corresponds to the data in the update. The system then attaches this signature to the update and sends the entire package to the target system. When the target system receives the signed update, it verifies the data by using the same private key to generate a second digital signature from the data. If the signatures match, the target system knows that the update came from the a trusted system and that it is safe to use.

You can use cryptographic authentication for many purposes, including:

- Secure dynamic updates — Allow the master server to authenticate the updates it receives from clients.
- Secure zone updates — Allow the master server to authenticate zone transfer requests it receives from the slave servers, and subsequently, allow slave servers to authenticate the zone transfers they receive from the master server.

For either of these applications, if the data is not correctly signed (by a trusted host), it is rejected.

See Section 2.6 for information about configuring authentication for dynamic updates and zone transfers.

## 2.4 Planning DNS

Figure 2–3 shows the DNS Setup Worksheet, which you can use to record the information required to configure DNS. If you are viewing this manual online, you can use the print feature of your browser to print a copy of

this worksheet. The following sections explain the information you need to record on the worksheet.

**Figure 2–3: DNS Setup Worksheet**

| DNS Setup Worksheet  |   |                               |
|--|---|-------------------------------|
| Local domain name: _____   |   |                               |
| <b>Server</b>  |   |                               |
| Host name resolution: ___ /etc/hosts ___ DNS ___ NIS   |   |                               |
| Dynamic updates: <input type="checkbox"/> Yes <input type="checkbox"/> No  |   |                               |
| Authentication: <input type="checkbox"/> Dynamic updates <input type="checkbox"/> Zone transfers <input type="checkbox"/> None |   |                               |
| <b>Zones</b>   |   |                               |
| Zone domain name:  | Authority:  | Data file and server address: |
| _____  | <input type="checkbox"/> Primary <input type="checkbox"/> Secondary | _____                         |
| _____  | <input type="checkbox"/> Primary <input type="checkbox"/> Secondary | _____                         |
| _____  | <input type="checkbox"/> Primary <input type="checkbox"/> Secondary | _____                         |
| _____  | <input type="checkbox"/> Primary <input type="checkbox"/> Secondary | _____                         |
| <b>Forwarders</b>  |   |                               |
| Forwarder name: _____  |   |                               |
| <b>Client</b>  |   |                               |
| Server name:   | Internet address:   |                               |
| _____  | _____   |                               |
| _____  | _____   |                               |
| _____  | _____   |                               |
| _____  | _____   |                               |
| Host name resolution: ___ /etc/hosts ___ DNS ___ NIS   |   |                               |

**Local domain name**

For a master server, the domain for which the server has primary authority. For client systems, the parent domain of which your local system is a part. For example, if your system’s domain name is cxcxcx.abc.xyz.com, your local domain name is abc.xyz.com.

**2.4.1 Server**

**Host name resolution**

The order in which the local /etc/hosts file, DNS database, and NIS database are to be queried for host name resolution.

Indicate the order on the worksheet by placing the appropriate number next to each item. The following order is recommended:

1. Local hosts file
2. DNS database
3. NIS database

### **Dynamic updates**

Check Yes if you want to enable dynamic client updates; otherwise, check No.

### **Authentication**

If you want the master server to authenticate the DNS database updates it receives from clients, check Dynamic updates. If you want to authenticate zone transfers between master and slave servers, check Zone transfers. If you do not require authentication, check None.

If you plan to use the `nd6hostd` daemon to provide dynamic updates for IPv6 zones, do not enable authentication for these zones. The `nd6hostd` daemon does not support authentication.

### **Zone domain name**

The name of the top-level domain in the zone.

### **Authority**

If the server is a master server for the zone (maintains the zone database file), check Primary. If the server is a slave server for the zone (copies the zone database file from the master), check Secondary.

### **Data file and server address**

For a master server, the full directory and file name specification for the file in which the master database of zone information will be stored.

For a slave server or stub server, the full directory and file name specification for the file in which a local copy of the database from the master server will be stored. Also, the IP address of the master server.

### **Forwarder name**

The host name of a system or systems to which your server forwards queries that it cannot resolve locally. When the server receives a query that it cannot answer from its cache, it sends the query to a forwarder for resolution. If the forwarder cannot answer the query, the server might contact other servers directly. If your system is a Forward-only

server, you must include forwarder names; otherwise, forwarders are optional.

## 2.4.2 Client

### Server name

The name of a server to contact for host name resolution. Specify up to three servers.

### Internet address

A corresponding IP address for the server or servers.

### Host name resolution

The order in which the local `/etc/hosts` file, DNS database, and NIS database are to be queried for host name resolution.

Indicate the order on the worksheet by placing the appropriate number next to each item. The following order is recommended:

1. Local hosts file
2. DNS database
3. NIS database

## 2.5 Configuring DNS

Use the SysMan Menu application of the Common Desktop Environment (CDE) Application Manager to configure DNS on servers and clients. To invoke the SysMan Menu application, follow the instructions in Section 1.2.1.

When you configure DNS, you must first set up the master server. You can configure the other systems in any order.

### 2.5.1 Configuring a Master Server

To configure a master server, do the following:

---

**Note**

---

If you are configuring an IPv6 master server, see Section 2.5.1.1 for more information.

---

1. Copy into the `/etc/namedb/src` directory the hosts file that you want to convert to the DNS hosts database.

To create a new file from which the hosts database will be created, you can update the master server's local `/etc/hosts` file (see *Network Administration: Connections*) and copy it into the `/etc/namedb/src` directory with the same `hosts` file name. If a system is in your DNS domain and is running DNS but is not included in the master server's hosts database, other systems in the domain cannot obtain its IP address.

2. From the SysMan Menu, select Networking→Additional Network Services→Domain Name Service (DNS(BIND))→Configure system as a DNS server to display the DNS Server Configuration dialog box.

Alternatively, enter the following command on a command line:

```
# /usr/bin/sysman dns_server
```

3. Enter your local domain name, the domain for which the master server will have primary authority, in the Local Domain field.
4. Select MASTER in the DNS Server Type pull-down menu.
5. Indicate the order in which to resolve host name queries in the Host Name Resolution Order field. Open the pull-down menu and choose from the list of options. Administrators usually use either the DNS Database, Local Host File, NIS option or the Local Host File, DNS Database, NIS option; the latter is recommended. Your choice is recorded in the `/etc/svc.conf` file.

Alternatively, you can run the `svcsetup` script to customize service order selection. See Section 2.8.1 and `svcsetup(8)` for information about modifying the `svc.conf` file.

6. Select the Advanced DNS Options button to display the Advanced Options dialog box, which allows you to choose a different directory and files in which to save DNS server configuration information and cache data. Make changes, if necessary, then select OK to close the dialog box.
7. Select Next to display the Local Name Server list.
  - a. Select Add to display the Add Name Server dialog box.
  - b. Enter the host name and IP address for a name server that your master server will query for addresses it cannot resolve by itself.
  - c. Select OK to accept the entry. If the server is not a known host, select Yes to add it to the `/etc/hosts` file.

Repeat steps 7a through 7c, if necessary. It is best to specify two or three name servers.
  - d. Select OK to accept the list of name servers. The addresses are later recorded in the `/etc/resolv.conf` file.

8. Select the appropriate check box to create the DNS database. Specify the name of the source file to use in the Hosts File field. Use `/etc/namedb/src/hosts` for the file you created in step 1 or the default for `/etc/hosts`. Select Next to continue.
9. Select the appropriate check box to start the named daemon and select Next to continue. The utility prompts you to change the host name of the system.
10. Select the appropriate check box to change the host name, if necessary. If you choose to change the host name, you are prompted to add `localhost` to the access control list. Select Yes to allow graphical user interfaces to be displayed properly on your newly renamed system.
11. Select Next to continue, then select Finish to save the configuration and start the named daemon.

You are informed that you successfully configured the system as a DNS server. Select OK to close the DNS Server Configuration dialog box.

You can also modify your server configuration after the initial setup. See the online help for more information.

To enable dynamic updates on a DNS master server for IPv6 or Microsoft Windows network environments, see Section 2.5.1.2 and Section 2.6.

### 2.5.1.1 Configuring an IPv6 Master Server

Configuring an IPv6 master server is similar to configuring an IPv4 master server with a few exceptions. The following sections describe the exceptions.

#### 2.5.1.1.1 DNS Configuration Files

The `/usr/examples/ipv6/namedb` directory contains DNS configuration files that show sample IPv6 information for you to study and adapt to your environment. Of the files in that directory, the following files contain IPv6 information that show reverse lookup addresses and dynamic update examples:

- `/usr/examples/ipv6/namedb/ipv6.rev`
- `/usr/examples/ipv6/namedb/ipv6.db`
- `/usr/examples/ipv6/namedb/named.conf`

After you customize these files for your environment, save the original files in the `/etc/namedb` directory, then move the customized files to that directory.

#### 2.5.1.1.2 Server Guidelines

To configure a DNS server to operate in an IPv6 network environment, review the following guidelines:

- Select a node to function as an IPv6 name server.
- Dedicate a zone to IPv6 addresses or add IPv6 addresses to your enterprise's current zone.
- If you want global IPv6 name services, you must delegate a domain under the `ip6.int` domain for the reverse lookup of IPv6 addresses. Send mail to the following address to request a domain for reverse lookups:

`bmannings@isi.edu`

See RFC 1886 for more information.

See *Network Administration: Connections* for information on how to create a reverse lookup zone name.

- If the system is already configured as a DNS server, change the `/etc/resolv.conf` file to point to the local node for name lookups, as follows:

```
nameserver 127.0.0.1
```

### 2.5.1.2 Enabling Dynamic Updates to the DNS Database

To enable dynamic updates on a DNS master server for IPv6 or Microsoft Windows network environments, do the following:

---

#### Caution

---

Each time you reconfigure your DNS master server with the SysMan Menu, you must reenable dynamic updates by repeating these steps because your `named.conf` file will be rewritten.

---

1. Edit the `/etc/namedb/named.conf` file and add the `allow-update` substatement to the master zone statements (forward and reverse lookup) for which you want to enable dynamic updates, as follows:

```
zone "zone-name" {
    type master;
    file "file-name";
    allow-update { any; };
};

zone "rev-ip.in-addr.arpa" {
    type master;
    file "file-name.rev";
    allow-update { any; };
};
```

For example, if you are enabling dynamic updates in an IPv6 zone, the zone statements might appear as follows after the change:



```

zone "ipv6.site1.corp.example" {
    type master;
    file "ipv6.site1.db";
    allow-update { any; };
};
zone "0.4.c.8.0.0.0.4.c.8.0.1.0.0.1.2.0.0.f.5.IP6.INT" {
    type master;
    file "ipv6.site1.rev";
    allow-update { any; };
};

```

Note that specifying any in the allow-update substatements allows any client to update the master DNS database. If you prefer to limit access to the database, see Section 2.6 for information about enabling authentication of dynamic updates. (However, note that the `nd6hostd` daemon on IPv6 clients does not support authentication.)

2. Start or restart the named daemon. See the online help for more information.

For information about configuring Microsoft Windows 2000 systems on a network with Tru64 UNIX DNS servers, see the Best Practice for *Integrating Windows 2000 DNS Clients with Tru64 UNIX DNS Services* on the Tru64 UNIX Publications Home Page at the following URL:

<http://www.tru64unix.compaq.com/docs/>

## 2.5.2 Configuring a Slave Server

To configure a slave server, invoke the SysMan Menu as documented in Section 1.2.1 and do the following:

1. From the SysMan Menu, select Networking→Additional Network Services→Domain Name Service (DNS(BIND))→Configure system as a DNS server to display the DNS Server Configuration dialog box.

Alternatively, enter the following command on a command line:

```
# /usr/bin/sysman dns_server
```

2. Enter your local domain name in the Local Domain field.
3. Select SLAVE in the DNS Server Type pull-down menu.
4. Indicate the order in which to resolve host name queries in the Host Name Resolution Order field. Open the pull-down menu and choose from the list of options. Administrators usually use either the DNS Database, Local Host File, NIS option or the Local Host File, DNS Database, NIS option; the latter is recommended. Your choice is recorded in the `/etc/svc.conf` file.

Alternatively, you can run the `svcsetup` script to customize service order selection. See Section 2.8.1 and `svcsetup(8)` for information about modifying the `svc.conf` file.

5. Select the Advanced DNS Options button to display the Advanced Options dialog box, which allows you to choose a different directory and files in which to save DNS server configuration information and cache data. Make changes, if necessary, then select OK to close the dialog box.
6. Select Next to display the Zones Served list.
  - a. Select Add to display the Add Zone dialog box.
  - b. Select the Slave radio button in the Authority field and enter the name of the zone (domain) for which this server will have secondary authority.
  - c. Enter the name of the local file in which to store a copy of the database of zone information from the master server. Also, enter the IP address of the master server.
  - d. Select OK to accept the entry. Repeat steps 6a through 6d for additional entries. At the very least, you must add a forward lookup entry and reverse lookup entry for each zone.

Given the following `/etc/namedb/named.conf` file on the master server, you would add entries in the slave's Zones Served list for the `domain.suffix` and `nn.nnn.in-addr.arpa` zones:

```
zone domain.suffix {
    type master;
    file "hosts.db";
};

zone nn.nnn.in-addr.arpa {
    type master;
    file "hosts.rev";
};
```

7. Select Next to display the Local Name Server list.
  - a. Select Add to display the Add Name Server dialog box.
  - b. Enter the host name and IP address for a name server that your slave server will query for addresses that it cannot resolve by itself.
  - c. Select OK to accept the entry. If the server is not a known host, select Yes to add it to the `/etc/hosts` file.

Repeat steps 7a through 7c, if necessary. It is best to specify two or three name servers.

- d. Select Next to accept the list of name servers. The addresses are later recorded in the `/etc/resolv.conf` file.
8. Select the appropriate check box to start the named daemon and select Next to continue. The utility prompts you to change the host name of the system.
9. Select the appropriate check box to change the host name, if necessary. If you choose to change the host name, you are prompted to add `localhost` to the access control list. Select Yes to allow graphical user interfaces to be displayed properly on your newly renamed system.
10. Select Next to continue, then select Finish to save the configuration and start the named daemon.

You are informed that you successfully configured the system as a DNS server. Select OK to close the DNS Server Configuration dialog box.

You can also modify your server configuration after the initial setup. See the online help for more information.

### 2.5.3 Configuring a Caching-Only Server

To configure a caching-only server, invoke the SysMan Menu as documented in Section 1.2.1 and do the following:

1. From the SysMan Menu, select Networking→Additional Network Services→Domain Name Service (DNS(BIND))→Configure system as a DNS server to display the DNS Server Configuration dialog box.

Alternatively, enter the following command on a command line:

```
# /usr/bin/sysman dns_server
```

2. Enter your local domain name in the Local Domain field.
3. Select CACHING in the DNS Server Type pull-down menu.
4. Indicate the order in which to resolve host name queries in the Host Name Resolution Order field. Open the pull-down menu and choose from the list of options. Administrators usually use either the DNS Database, Local Host File, NIS option or the Local Host File, DNS Database, NIS option; the latter is recommended. Your choice is recorded in the `/etc/svc.conf` file.

Alternatively, you can run the `svcsetup` script to customize service order selection. See Section 2.8.1 and `svcsetup(8)` for information about modifying the `svc.conf` file.

5. Select the Advanced DNS Options button to display the Advanced Options dialog box, which allows you to choose a different directory and

files in which to save DNS server configuration information and cache data. Make changes, if necessary, then select OK to close the dialog box.

6. Select Next to display the Local Name Server list.
  - a. Select Add to display the Add Name Server dialog box.
  - b. Enter the host name and IP address for a name server that your caching-only server will query for addresses that it cannot resolve by itself.
  - c. Select OK to accept the entry. If the server is not a known host, select Yes to add it to the `/etc/hosts` file.  
Repeat steps 6a through 6c, if necessary. It is best to specify two or three name servers.
  - d. Select Next to accept the list of name servers. The addresses are later recorded in the `/etc/resolv.conf` file.
7. Select the appropriate check box to start the named daemon and select Next to continue. The utility prompts you to change the host name of the system.
8. Select the appropriate check box to change the host name, if necessary. If you choose to change the host name, you are prompted to add `localhost` to the access control list. Select Yes to allow graphical user interfaces to be displayed properly on your newly renamed system.
9. Select Next to continue, then select Finish to save the configuration and start the named daemon.  
You are informed that you successfully configured the system as a DNS server. Select OK to close the DNS Server Configuration dialog box.

You can also modify your server configuration after the initial setup. See the online help for more information.

## 2.5.4 Configuring a Forward-Only Server

To configure a forward-only server, invoke the SysMan Menu as documented in Section 1.2.1 and do the following:

1. From the SysMan Menu, select Networking→Additional Network Services→Domain Name Service (DNS(BIND))→Configure system as a DNS server to display the DNS Server Configuration dialog box.  
Alternatively, enter the following command on a command line:  

```
# /usr/bin/sysman dns_server
```
2. Enter your local domain name in the Local Domain field.
3. Select FORWARDER in the DNS Server Type pull-down menu.

4. Indicate the order in which to resolve host name queries in the Host Name Resolution Order field. Open the pull-down menu and choose from the list of options. Administrators usually use either the DNS Database, Local Host File, NIS option or the Local Host File, DNS Database, NIS option; the latter is recommended. Your choice is recorded in the `/etc/svc.conf` file.

Alternatively, you can run the `svcsetup` script to customize service order selection. See Section 2.8.1 and `svcsetup(8)` for information about modifying the `svc.conf` file.

5. Select the Advanced DNS Options button to display the Advanced Options dialog box, which allows you to choose a different directory and files in which to save DNS server configuration information and cache data. Make changes, if necessary, then select OK to close the dialog box.
6. Select Next to display the Forwarders list.
  - a. Select the appropriate check box to indicate that you want to configure the system as a forward-only server.
  - b. Select Add to display the Add Forwarder dialog box.
  - c. Enter the IP address for a forwarder, a name server that your forward-only server will query for addresses on remote networks (like the Internet).
  - d. Select OK to accept the entry. If the server is not a known host, select Yes to add it to the `/etc/hosts` file.  
  
Repeat steps 6b through 6d, if necessary. It is best to specify two or three forwarders.
  - e. Select Next to accept the list of forwarders. The addresses are later recorded in the `/etc/resolv.conf` file.
7. Select Next to display the Local Name Server list.
  - a. Select Add to display the Add Name Server dialog box.
  - b. Enter the host name and IP address for a name server that your forward-only server will query for addresses on the local network.
  - c. Select OK to accept the entry. If the server is not a known host, select Yes to add it to the `/etc/hosts` file.  
  
Repeat steps 7a through 7c, if necessary. It is best to specify two or three name servers.
  - d. Select Next to accept the list of name servers. The addresses are later recorded in the `/etc/resolv.conf` file.

8. Select the appropriate check box to start the `named` daemon and select Next to continue. The utility prompts you to change the host name of the system.
9. Select the appropriate check box to change the host name, if necessary. If you choose to change the host name, you are prompted to add `localhost` to the access control list. Select Yes to allow graphical user interfaces to be displayed properly on your newly renamed system.
10. Select Next to continue, then select Finish to save the configuration and start the `named` daemon.

You are informed that you successfully configured the system as a DNS server. Select OK to close the DNS Server Configuration dialog box.

You can also modify your server configuration after the initial setup. See the online help for more information.

## 2.5.5 Configuring a Stub Server

To configure a stub server, invoke the SysMan Menu as documented in Section 1.2.1 and do the following:

---

### Note

---

When configuring stub service, run the SysMan Menu application on the server that will have authority for the subzone, not on the master server. See the definition for a stub server in Section 2.1 for more information.

---

1. From the SysMan Menu, select Networking→Additional Network Services→Domain Name Service (DNS(BIND))→Configure system as a DNS server to display the DNS Server Configuration dialog box.

Alternatively, enter the following command on a command line:

```
# /usr/bin/sysman dns_server
```

2. Enter your local domain name in the Local Domain field.
3. Select STUB in the DNS Server Type pull-down menu.
4. Indicate the order in which to resolve host name queries in the Host Name Resolution Order field. Open the pull-down menu and choose from the list of options. Administrators usually use either the DNS Database, Local Host File, NIS option or the Local Host File, DNS Database, NIS option; the latter is recommended. Your choice is recorded in the `/etc/svc.conf` file.

Alternatively, you can run the `svcsetup` script to customize service order selection. See Section 2.8.1 and `svcsetup(8)` for information about modifying the `svc.conf` file.

5. Select the Advanced DNS Options button to display the Advanced Options dialog box, which allows you to choose a different directory and files in which to save DNS server configuration information and cache data. Make changes, if necessary, then select OK to close the dialog box.
6. Select Next to display the Zones Served list.
  - a. Select Add to display the Add Zone dialog box.
  - b. Select the Stub radio button in the Authority field. Enter the name of the stub zone (domain).
  - c. Enter the name of the local file in which to store a copy of the database of zone information from the master server. Also, enter the IP address of the master server.
  - d. Select OK to accept the entry. Repeat steps 6a through 6d for additional entries. At the very least, you must add a forward lookup entry and a reverse lookup entry for each zone.

Given the following `/etc/namedb/named.conf` file on the master server, you would add entries in the slave's Zones Served list for the `domain.suffix` and `nn.nnn.in-addr.arpa` zones:

```
zone domain.suffix {
    type master;
    file "hosts.db";
};

zone nn.nnn.in-addr.arpa {
    type master;
    file "hosts.rev";
};
```

7. Select Next to display the Local Name Server list.
  - a. Select Add to display the Add Name Server dialog box.
  - b. Enter the host name and IP address for a name server that your stub server will query for addresses that it cannot resolve by itself.
  - c. Select OK to accept the entry. If the server is not a known host, select Yes to add it to the `/etc/hosts` file.  
Repeat steps 7a through 7c, if necessary. It is best to specify two or three name servers.
  - d. Select Next to accept the list of name servers. The addresses are later recorded in the `/etc/resolv.conf` file.

8. Select the appropriate check box to start the `named` daemon and select Next to continue. The utility prompts you to change the host name of the system.
9. Select the appropriate check box to change the host name, if necessary. If you choose to change the host name, you are prompted to add `localhost` to the access control list. Select Yes to allow graphical user interfaces to be displayed properly on your newly renamed system.
10. Select Next to continue, then select Finish to save the configuration and start the `named` daemon.

You are informed that you successfully configured the system as a DNS server. Select OK to close the DNS Server Configuration dialog box.

You can also modify your server configuration after the initial setup. See the online help for more information.

## 2.5.6 Configuring a DNS Client

To configure a DNS client, invoke the SysMan Menu as documented in Section 1.2.1 and do the following:

1. From the SysMan Menu, select Networking→Additional Network Services→Domain Name Service (DNS(BIND))→Configure system as a DNS client to display the Configure DNS Client dialog box.

Alternatively, enter the following command on a command line:

```
# /usr/bin/sysman dns_client
```

2. Enter your local domain name in the Local Domain field.
3. Select Add to add a name server.
4. Enter the host name and the IP address for the name server.

The addresses are recorded in the `/etc/resolv.conf` file, where the resolver uses them to determine the IP addresses of name servers it will query.

5. Select OK to add the host name to the list of name servers. If the specified host is not listed in the `/etc/hosts` file, the script prompts you to add it to that file. Select Yes or No.

To add other name servers, repeat steps 3 through 5. You can specify up to three name servers.

6. Indicate the order in which to resolve host name queries in the Host Name Resolution Order field. Open the pull-down menu and choose from the list of options. Administrators usually use either the DNS Database, Local Host File, NIS option or the Local Host File, DNS



Database, NIS option; the latter is recommended. Your choice is recorded in the `/etc/svc.conf` file.

Alternatively, you can run the `svcsetup` script to customize service order selection. See Section 2.8.1 and `svcsetup(8)` for information about modifying the `svc.conf` file.

7. Configure your system to search alternate domains for address resolution by doing the following:
  - a. Select Domains Searched to display the associated dialog box.
  - b. Select Add to display the Add/Modify dialog box.
  - c. Enter the name of a domain to search. Your local domain is searched by default; you do not need to enter it.
  - d. Select OK to accept the entry. Repeat steps 7b through 7d, if necessary. You can specify up to six domains.
  - e. Select OK to accept the list of domains to be searched.
8. Select OK to accept the configuration. The script prompts you to change the host name of the system.
9. Select Yes or No as appropriate. If you choose Yes to change the host name, you are prompted to add `localhost` to the access control list. Select Yes to allow graphical user interfaces to be displayed properly on your newly renamed system.
10. Select OK to close the Configure DNS Client dialog box.

You can also modify your client configuration after the initial setup. See the online help for more information.

For IPv6 network environments, to enable dynamic updates for a DNS client, do the following:

1. Run the `ip6_setup` script and enable dynamic updates of IPv6 addresses by entering `y` at the prompt. Provide a fully qualified domain name for the IPv6 host. See *Network Administration: Connections* for more information.
2. Configure the DNS/BIND server to allow the updates (see Section 2.5.1.2).

If you do not want to enable dynamic updates, you must still run the `ip6_setup` script, but no special DNS configuration is necessary.

## 2.6 Configuring Authentication

The following sections describe how to configure authentication on DNS servers for the following purposes:

- Secure dynamic updates
- Secure zone transfers

Authentication is useful only when the private key remains a secret between the servers; therefore, it is prudent to change this key frequently and save the key file as specified in the following sections to prevent the key from being compromised.

### 2.6.1 Configuring Secure Dynamic Updates

If you plan to use the `nd6hostd` daemon to dynamically update IPv6 zones, do not enable authentication for these zones. The `nd6hostd` daemon does not support authentication.

To configure a master server to authenticate dynamic updates it receives from new DNS clients (Microsoft Windows systems), do the following:

---

#### Caution

---

Each time you reconfigure your DNS master server with the SysMan Menu, you must reenable secure client updates by repeating these steps because your `named.conf` file will be rewritten.

---

1. Generate a private key using the `dnskeygen` command, as follows:

```
# dnskeygen -H size -h -c -n key-name
```

Valid key sizes are 512, 576, 640, 704, 768, 832, 896, 960, and 1024 bytes. Larger keys are more cumbersome, but they are more secure.

You can supply any name for a key, but it is best to give the keys canonical names so they are easy to distinguish. For example, if hosts from the `xyz.corp.com` zone send dynamic updates to your master server, `marlin.xyz.corp.com`, you might want to name your key `xyznet-marlin_update`.

The `dnskeygen` command produces two files:

- `K<key-name><proto-id><key-id>.key`
- `K<key-name><proto-id><key-id>.private`

Hereafter, these files are referred to as the `.key` and `.private` files.

For more information about generating keys, see `dnskeygen(1)`.

2. Create a file to contain the key configuration statement for the update. This file must be read/writeable only by superuser to prevent the private key from being compromised. For example:

```
# cd /etc/namedb
# touch key-config-file
# chmod 600 key-config-file
```

Although it is not necessary, you might want to call the *key-config-file* named *.keys*.

3. Incorporate the key information from the *.private* file into the *key-config-file* by adding the following key statement:

```
key key-name {
    algorithm hmac-md5;
    secret "generated-key";
};
```

In the key statement, replace *key-name* with the name of the key and replace *generated-key* with the entire private key as it appears in the *.private* file. It is best to enter the key by opening the *.private* file in another window, copying the necessary key text, and pasting the text into the text editor window. There must be no line feeds or spaces between the quotes that contain the key; if even one character is entered incorrectly, authentication fails.

4. Add the following include statement to the top of the */etc/namedb/named.conf* file:

```
include "/etc/namedb/key-config-file";
```

Replace *key-config-file* with the name of the key configuration file you created in steps 2 and 3.

When the named daemon starts and reads the DNS data file, it calls the *key-config-file* and parses its contents.

5. Enable secure dynamic updates for the master zone by adding the *allow-update* substatement to the master zone statements (for forward and reverse lookups) in the *named.conf* file :

```
zone "zone-name" {
    type master;
    file "file-name";
    allow-update {
        key key-name;
    };
};

zone "rev-ip.in-addr.arpa" {
    type master;
    file "hosts.rev";
    allow-update {
        key key-name;
    };
};
```

Replace *key-name* with the name of the file you created in steps 2 and 3.

Specifying a key in this statement ensures that updates are successful only if they are signed with the private key.

6. Restart the named daemon by issuing the following command:

```
# /sbin/init.d/named restart
```

After you configure the master server to support secure dynamic DNS updates from new hosts, you can distribute the private key as necessary to administrators who need to add these hosts to the network. It is best to physically distribute the key on magnetic or optical media as opposed to sending it over the network where it can be compromised.

You can format a floppy disk for this purpose. See `mttools(1)` for information about formatting and reading Microsoft Windows-compatible floppy disks on a Tru64 UNIX system. If the described tools are not available, you need to install the `OSFDOSTOOLS` subset.

For information about configuring Microsoft Windows 2000 systems on a network with Tru64 UNIX DNS servers, see the Best Practice for *Integrating Windows 2000 DNS Clients with Tru64 UNIX DNS Services* on the Tru64 UNIX Publications Home Page at the following URL:

**<http://www.tru64unix.compaq.com/docs/>**

Note that when clients send updates to the master server, the named daemon does not immediately update the master database files. It creates temporary `database.ixfr` and `database.log` files where it logs the changes until they can be incorporated into the database. However, almost immediately, the daemon becomes aware of the updates in memory. You can verify them with the `nslookup` command as explained in Section 2.8.3.1.

## 2.6.2 Configuring Secure Zone Transfers

To configure a master server and slave servers to use authentication for zone transfers, do the following:

---

### Caution

---

Each time you reconfigure DNS with the SysMan Menu, you must reenable secure zone transfers by repeating these steps because your `named.conf` file will be rewritten.

---

1. On the master server, perform steps 1–4 as specified in Section 2.6.1.

When creating a key name, choose a name that describes the zone transfer. For example, if the master server, `marlin.xyz.corp.com`, is sending updates to the slave server, `minnow.xyz.corp.com`, for the `xyz.corp.com` zone, you might name the key `xyznet-marlin-minnow_transfer`.

2. On the master server, add the `allow-transfer` substatement to the master zone statements (for forward and reverse lookups) in the `/etc/namedb/named.conf` file:

```
include "/etc/namedb/key-file";
.
.
.
zone "zone-name" {
    type master;
    file "hosts.db";
    allow-transfer {
        key key-name;
    };
};

zone "rev-ip.in-addr.arpa" {
    type master;
    file "hosts.rev";
    allow-transfer {
        key key-name;
    };
};
```

Replace `key-name` with the name of the key as you specified it in the key configuration file you created in steps 2 and 3 of Section 2.6.1.

Adding this server statement ensures that the master server transfers the zone only if the request is signed with the private key. It also ensures that the master server signs the zone transfer with the key before it sends the data to the slave server.

3. Transfer the key configuration file (`key-config-file` or `named.keys`) from the master server to the slave server(s). It is best to physically transfer this file on magnetic or optical media as opposed to sending it over the network where it can be compromised.

You can format a floppy disk for this purpose. See `mttools(1)` for information about formatting and reading Microsoft Windows-compatible floppy disks on a Tru64 UNIX system. If the described tools are not available, you need to install the `OSFDOSTOOLS` subset.

On the slave server(s), ensure that the permissions are set for read/writable only by superuser:

```
# chmod 600 key-config-file
```

4. On the slave server(s), add an include statement to the `named.conf` file to call the `key-config-file`. Also, insert the `server` statement after the include statement and before any zone statements:

```
include "/etc/namedb/key-config-file";
.
.
.
server ip-address {
    keys {key-name};
};
```

Replace `key-config-file` with the name of the key configuration file you copied from the master server. Replace `ip-address` with the IP address of the master server. Finally, replace `key-name` with the name of the key you specified in the `key-config-file`.

Adding the `server` statement ensures that the slave server signs requests for zone transfers from the master server with the private key. It also ensures that the slave server authenticates signed zone transfers from the master server before it incorporates them into its data files.

5. Restart the `named` daemon on the master server and the slave server(s) by issuing the following command:

```
# /sbin/init.d/named restart
```

### 2.6.3 Authentication Example

The following examples show sample `named.keys` and `named.conf` files that implement both secure dynamic updates and secure zone transfers. These configuration files describe a network in which there is a DNS master server called `marlin.ocean.corp.com` and a slave server called `minnow.ocean.corp.com`.

#### Example 2–1: Sample `named.keys` File for Authentication

---

```
key oceannet-client_update { 1
    algorithm hmac-md5; 2
    secret "lSYbJjbTOLH2DB+kRpf0fcTJk0mOca90GDGdn5R7L2vPhyCx
daGhHp0o2pDU+PSzclE3Yk6Xg8jOkpRExx+2yw==" ; 3
};

key oceannet-marlin-minnow_transfer { 4
    algorithm hmac-md5;
    secret "648NyJi33LMhf00iavHjbkgqcTMJ71ZD4/r0DF9wgIQ2WH2b
peHLYjz2qYMrx1dMYw9E9gDp6F6LTMDHHCvFlw==" ;
```

---

In Example 2–1, the lines serve the following purpose:

- ❶ Defines the `oceannet-client_update` key, which will be used for secure dynamic updates from clients in the `ocean.corp.com` zone.
- ❷ Specifies the encryption algorithm. Keys for dynamic updates and zone transfers must be `hmac-md5`.
- ❸ Specifies the key string. This string must contain no spaces or carriage returns.
- ❹ Defines the `oceannet-marlin-minnow_transfer` key, which will be used for zone transfers between the master server, `marlin.ocean.corp.com`, and the slave server, `minnow.ocean.corp.com`.

---

#### Example 2–2: Sample Master Server `named.conf` File for Authentication

```
include "/etc/namedb/named.keys"; ❶

options {
    directory "/etc/namedb/";
};

zone "0.0.127.in-addr.arpa" {
    type master;
    file "named.local";
};

zone "ocean.corp.com" {
    type master;
    file "hosts.db";
    allow-update {
        key oceannet-client_update; ❷
    };
    allow-transfer {
        key oceannet-marlin-minnow_transfer; ❸
    };
};

zone "6.134.20.in-addr.arpa" {
    type master;
    file "hosts.rev";
    allow-update {
        key oceannet-client_update; ❷
    };
    allow-transfer {
        key oceannet-marlin-minnow_transfer; ❸
    };
};

zone "." {
```

### Example 2–2: Sample Master Server named.conf File for Authentication (cont.)

---

```
        type hint;
        file "named.ca";
};
```

---

In Example 2–2, the lines serve the following purpose:

- ❶ Calls the aforementioned named.keys file into the named.conf file.
- ❷ Specify that dynamic updates for the ocean.corp.com zone must be authenticated with the oceannet-client\_update key before they are incorporated into the DNS database.
- ❸ Specify that zone transfer requests for the ocean.corp.com zone must be authenticated with the oceannet-marlin-minnow\_transfer key before any data is sent to the slave server(s).

### Example 2–3: Sample Slave Server named.conf File for Authentication

---

```
include "/etc/namedb/named.keys";

server 20.134.6.2 {
    keys { oceannet-marlin-minnow_transfer }; ❶
};

options {
    directory "/etc/namedb/";
};

zone "0.0.127.in-addr.arpa" {
    type master;
    file "named.local";
};

zone "pubs.zk3.dec.com" {
    type slave;
    file "/etc/namedb/hosts.db";
    masters {
        20.134.6.2; ❷
    };
};

zone "6.134.20.in-addr.arpa" {
    type slave;
    file "/etc/namedb/hosts.rev";
    masters {
        20.134.6.2; ❷
    };
};
```



### Example 2–3: Sample Slave Server named.conf File for Authentication (cont.)

---

```
};  
};  
  
zone "." {  
    type hint;  
    file "named.ca";  
};
```

---

In Example 2–3, the lines serve the following purpose:

- ❶ Specifies that the slave server is to use the `oceannet-marlin-minnow_transfer` key for authentication of all communication between itself and `20.134.6.2` (`marlin.ocean.corp.com`).
- ❷ Specify that `20.134.6.2` is the master server for the `ocean.corp.com` zone, and that it will provide the authoritative data for that zone.

For more information about the statements in the `named.conf` file, see `named.conf(4)` and the *Bind Configuration File Guide* on the Tru64 UNIX Documentation CD-ROM.

## 2.7 Deconfiguring DNS

Use the SysMan Menu application of the Common Desktop Environment (CDE) Application Manager to deconfigure DNS servers and clients. To invoke the SysMan Menu application, follow the instructions in Section 1.2.1.

When you deconfigure DNS, the service stops and the DNS server and client configuration information is deleted from the system. This action cannot be undone. To restore DNS, you must configure it again using the SysMan Menu.

To deconfigure DNS, do the following:

1. From the SysMan Menu, select **Networking**→**Additional Network Services**→**Domain Name Service (DNS(BIND))**→**Deconfigure DNS** on this system to display the Deconfigure DNS dialog box.

Alternatively, enter the following command on a command line:

```
# /usr/bin/sysman dns_deconfigure
```

2. Select **Yes** to deconfigure DNS on the system.
3. Select **OK** to close the Deconfigure DNS dialog box.

## 2.8 Managing DNS Servers and Clients

This section describes how to perform the following DNS tasks:

- Modify the `svc.conf` file with the `svcsetup` script
- Update DNS data files on the master server
- Obtain host name and IP address information

### 2.8.1 Modifying the `svc.conf` File with `svcsetup`

You can modify the `/etc/svc.conf` file without running the DNS Configuration application. To do this, you invoke the `svcsetup` script using the following command:

```
# /usr/sbin/svcsetup
```

Once invoked, use the following steps to edit the `/etc/svc.conf` file:

1. Press the Return key following the informational messages to continue.
2. Press the Return key to choose the `m` option from the Configuration Menu.
3. Choose option 2 from the Change Menu. Option 2 corresponds to the `hosts` database.
4. Enter the number that corresponds to the order in which you want the services running on your system queried for `hosts` data.

Listing local first means that the local `/etc/hosts` file is searched first for the requested information. If the information is not found locally, then DNS servers, NIS servers, or both, are queried, depending on which options you choose.

---

#### Note

---

For better performance, it is best if the first service that your system queries for all databases is local, regardless of what services you are running.

---

Choose option 3, 4, 5, or 6 to configure the `svc.conf` file so that DNS serves `hosts` information.

The `svcsetup` script indicates that it is updating the `/etc/svc.conf` file. When the script is finished updating the file, it notifies you and the system prompt (`#`) is displayed.

## 2.8.2 Updating DNS Data Files on the Master Server

If you have not configured dynamic updates, as discussed in Section 2.2 and Section 2.5.1.2, you will need to manually update the DNS data files when you connect new hosts to the network.

To add a new host, follow these steps:

1. Edit the `/etc/namedb/src/hosts` file to add the new host.
2. Change to the `/etc/namedb` directory and enter one of the following commands:

```
# make hosts
# make all
```

After you edit the `hosts` file and enter the `make` command, the DNS conversion scripts (which are in the `/etc/namedb/bin` directory) do the following for you:

1. Create the new hosts databases: `hosts.db` and `hosts.rev`.
2. Place the new databases in the `/etc/namedb` directory.
3. Send a signal to the `named` daemon to reload all databases that have changed.

---

### Note

---

If you have manually entered mail exchanger (MX) records in the `named.local` file, these records are lost. You will have to edit the `named.local` file and add the MX records.

---

The DNS database conversion scripts also increment the serial number field of the start of authority (SOA) entry in the database file and inform the slave servers that it is time to refresh their data.

The process is the same for all of the valid files in the master server's `/etc/namedb/src` directory. Scripts are provided to create the `named.local` and `named.ca` databases.

## 2.8.3 Obtaining Host Name and IP Address Information

There are several ways that you can obtain information about host names, IP addresses, and user information from a system using DNS. The following sections provide an introduction to two commands: `nslookup` and `whois`.

### 2.8.3.1 The nslookup Command

You can use the `nslookup` command to noninteractively and interactively query DNS for information about hosts on local and remote domains. You can also find information about DNS resource records such as mail exchanger (MX), name server (NS), and so forth.

For a noninteractive query, use the following syntax:

```
nslookup hostname
```

The output is the server name and address and the host name and address.

For an interactive query, use the following syntax:

```
nslookup
```

The output is the default server name and address and the `nslookup` prompt, a greater than sign (>).

For example, to obtain information about MX, you need to query `nslookup` interactively, supplying a valid domain name. The following example shows how to find the mail recipient for the domain `corp.com`:

```
# nslookup
Default Server: localhost
Address: 127.0.0.1

> set querytype=mx
> corp.com
Server: localhost
Address: 127.0.0.1
findmx.corp.com preference = 100, mail exchanger = gateway.corp.com
gateway.corp.com inet address = 128.54.54.79
> Ctrl/D
#
```

A good way to learn how to use the `nslookup` command is to experiment with it. To obtain a list of the interactive `nslookup` command options, enter a question mark (?) at the `nslookup` prompt. For further information, see `nslookup(1)`.

For a detailed description of the many different types of DNS resource records, see Appendix G.

### 2.8.3.2 NIC whois Service

The Network Information Center (NIC) `whois` service allows you to access the following information about a domain:

- The name of the domain
- The name and address of the organization responsible for the domain
- The domain's administrative, technical, and zone contacts

- The host names and network addresses of sites providing DNS for the domain
- The registered users in the domain

For example, to use the NIC `whois` service to obtain information about a domain named `compaq.com`, use the `whois` command and specify the domain name as follows:

```
# whois compaq.com
Registrant:
Compaq Computer Corporation (COMPAQ-DOM)
  P.O. Box 692000
  Houston, TX 77269

Domain Name: COMPAQ.COM
:

The InterNIC Registration Services database contains ONLY
non-military and non-US Government Domains and contacts.
Other associated whois servers:
  American Registry for Internet Numbers - whois.arin.net
  European IP Address Allocations       - whois.ripe.net
  Asia Pacific IP Address Allocations    - whois.apnic.net
  US Military                            - whois.nic.mil
  US Government                          - whois.nic.gov
```

To query other `whois` servers, use the `-h` option:

```
# whois -h whois.nic.gov whitehouse.gov
Whitehouse Public Access (WHITEHOUSE-DOM)
  725 17th Street NW Room NEOB 4208
  Washington, DC 20503

Domain Name: WHITEHOUSE.GOV
Status: ACTIVE
Domain Type: Federal
:
```



---

## Network Information Service

The Network Information Service (NIS, formerly Yellow Pages) is a distributed data lookup service for sharing information on a local area network (LAN). NIS allows you to coordinate the distribution of database information throughout your networked environment.

This chapter describes:

- The NIS environment (Section 3.1)
- How to plan for your NIS configuration (Section 3.2)
- How to configure your system for NIS (Section 3.3)
- How to manage an NIS server (Section 3.4)
- How to manage an NIS client (Section 3.5)

For introductory information on NIS, see `nis_intro(7)`. For troubleshooting information, see Section 9.6 for clients and Section 9.5 for servers.

### 3.1 NIS Environment

In an NIS environment, systems can have the following roles:

- **Master server** — A system that stores the master copy of the NIS database files, or maps, for the domain in the `/var/yp/DOMAIN` directory and propagates them at regular intervals to the slave servers. Only the master maps can be modified. Each domain can have only one master server.
- **Slave server** — A system that obtains and stores copies of the master server's NIS maps. These maps are updated periodically over the network. If the master server is unavailable, the slave servers continue to make the NIS maps available to clients. Each domain can have multiple slave servers distributed throughout the network.
- **Client** — Any system that queries NIS servers for NIS database information. Clients do not store and maintain copies of the NIS maps locally for their domain.

Figure 3–1 shows a domain in which there is a master server, two slave servers, and some clients.

**Figure 3–1: NIS Configuration**

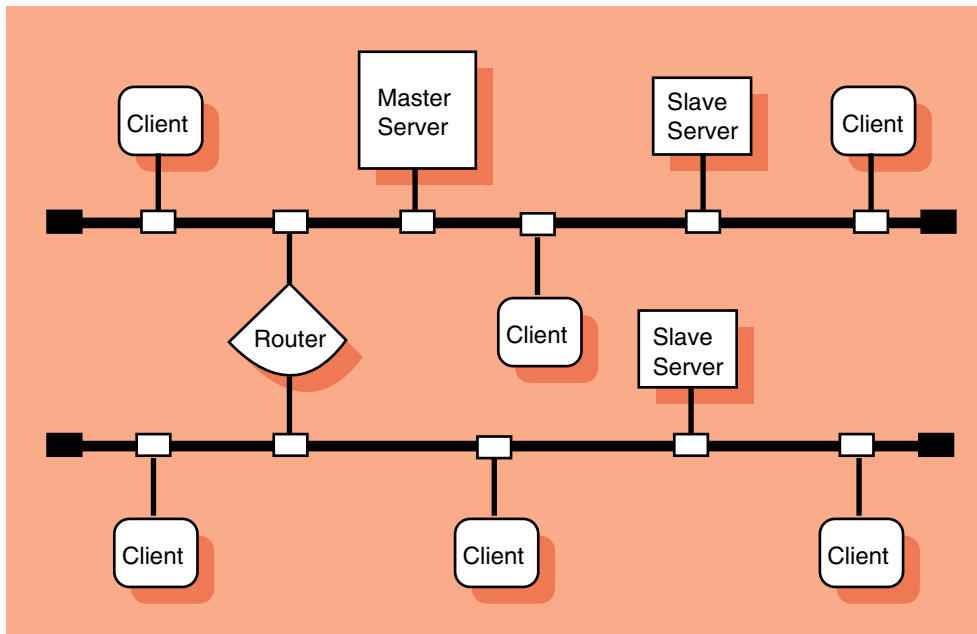

ZK-1145U-AI

By default, NIS distributes the aliases (`mail.aliases`), `group`, `hosts`, `netgroup`, `networks`, `passwd`, `protocols`, `rpc`, and `services` databases. (The `mail.aliases` and `netgroup` databases are created exclusively for NIS.) You can also create and distribute the enhanced security extended profile database, and site-specific customized databases, such as NFS Automount and AutoFS maps.

To configure NIS with support for enhanced security, and optionally create secure versions of NIS maps, carefully read the instructions in the *Creating and Maintaining Accounts* chapter of the *Security* guide before proceeding with the setup described in this chapter. For information on creating Automount and AutoFS maps for distribution by NIS, see Appendix A. For information on creating and distributing other site-specific NIS maps, see the Section 3.4.6.



## 3.2 Planning NIS

This section describes the tasks you must complete before configuring NIS.

### 3.2.1 Verifying That the Additional Networking Services Subset is Installed

For NIS servers, verify that the Additional Networking Services subset is installed by entering the following command:

```
# setld -i | grep OSFINET
```

If the subset is not installed, install it by using the `setld` command. For more information on installing subsets, see `setld(8)` or the *Installation Guide*.

### 3.2.2 Preparing for the Configuration

Figure 3–2 shows the NIS Setup Worksheet, which you can use to record the information required to configure NIS. If you are viewing this manual online, you can use the print feature to print a copy of this worksheet. The following sections explain the information you need to record on the worksheet.

**Figure 3–2: NIS Setup Worksheet**

| NIS Setup Worksheet  |  |
|----------------------|--|
|                      | Domain name: _____   |
| <b>Master Server</b> | Database files for NIS maps: _____<br>_____<br>_____<br>_____<br>_____<br><br>/var/yp/src/mail.alias file: <input type="checkbox"/> Yes <input type="checkbox"/> No<br>/var/yp/src/netgroup file: <input type="checkbox"/> Yes <input type="checkbox"/> No<br>Setup options: _____<br>Slave name: _____<br>IP address: _____<br>Slave name: _____<br>IP address: _____ |
| <b>Slave Server</b>  | Setup options: _____<br>Master name: _____<br>IP address: _____<br>Slave name: _____<br>IP address: _____<br>Slave name: _____<br>IP address: _____  |
| <b>Client</b>        | Setup options: _____<br>Server name: _____<br>Server name: _____   |

**Domain name**

The domain name (1 to 31 alphanumeric characters). All systems in the domain must declare the same domain name.

An NIS domain is an administrative entity that consists of a master server, one or more slave servers, and numerous clients. All systems in a domain share the same set of NIS database files.

**Note**

An NIS domain name is not the same as a DNS domain name. Furthermore, an NIS domain name is case-sensitive. Be very careful when specifying it. If you configure the system with an incorrect NIS domain name, all NIS-related operations (such as logging in and `ls -l` commands) hang for several minutes, then fail.

NIS runs on each system in your network. You must decide what role each system will play within the NIS domain that you are creating. Select one host to be the master server; there can be only one master server for each domain. Select one or more hosts to be slave servers. The rest of the hosts can run as NIS clients. (The master server and all slave servers are also considered to be NIS clients.)

Once you have determined a role for each system, fill in the remainder of the worksheet as specified in the following sections.

### 3.2.2.1 Master Server

#### Database files for NIS maps

The files you want to make into NIS maps. Choose from the following list:

- `/etc/group`
- `/etc/hosts`
- `/etc/networks`
- `/etc/passwd`
- `/etc/protocols`
- `/etc/rpc`
- `/etc/services`

#### **`/var/yp/src/mail.aliases` file**

The `mail.aliases` file, which is based on the `/var/adm/send-mail/aliases` file, defines network-wide mail aliases. If you want to define and distribute mail aliases on your network, check Yes; otherwise, check No.

If you choose not to create a `mail.aliases` file, the `nissetup` script issues an informational message that it cannot find the `mail.aliases` file while it is building the NIS maps. For information on defining mail aliases, see `aliases(4)`.

#### **`/var/yp/src/netgroup` file**

The `netgroup` file defines network-wide groups and is used for permission checking when doing remote mounts, remote logins, and remote shells. If you want to define and distribute `netgroup` information on your network, check Yes; otherwise, check No.

If you choose not to create a `netgroup` file, the `nissetup` script issues an informational message that it cannot find the `netgroup` file while

it is building the NIS maps. For information on defining network groups, see `netgroup(4)`.

### Setup options

The list of setup options for master servers is as follows. Write the options you want to use in the appropriate place in the worksheet.

- Run the `yppasswdd` daemon.

The `yppasswdd` daemon allows users to update their passwords in the master copy of the password file by issuing the `yppasswd` command on any system in the NIS domain. If you want users to be able to update their NIS-distributed passwords without administrator intervention, run the `yppasswdd` daemon.

The `yppasswdd` daemon runs only on the master server.

- Create base or enhanced security versions of the NIS maps.

Tru64 UNIX security can be configured in either base or enhanced authentication mode. Enhanced security includes an additional `prpasswd` map that contains extended user profile information. Before configuring NIS to distribute this `prpasswd` map, read Chapter 12 of the *Security* manual. It describes important operational differences and additional steps necessary for NIS configuration in a secure environment.

- Create NIS maps in `btree` format.

If you serve very large maps, you might want to have NIS maintain these maps as `btree` files, which significantly reduces the time required to build and push very large maps. However, the use of `btree` files might degrade performance slightly for relatively small maps. See `btree(3)` for more information about the `btree` format.

If you intend to use enhanced security with NIS, it is best to maintain your maps in `btree` format.

- Run the `yplibind` daemon with the `-s` option, which requires the server to use a reserved port.

For security purposes, it is best to run NIS with the `-s` option.

- Lock the `yplibind` daemon to a particular domain name and server list by specifying the `-S` option.

Normally, hosts broadcast NIS requests on the network and the first available server answers the request. The `-s` option allows you to lock the `yplibind` daemon to a particular domain and set of servers. Requests are made directly to the specified servers, rather than being broadcast. For security purposes, it is best to run NIS with the `-S` option.

If you choose to run NIS with the `-S` option, you must know the host names and IP addresses of the servers to which you are locking the `ybind` daemon. You will add them to the local `hosts` file during configuration.

---

### Security Note

---

When using the `nissetup` script to set up an NIS server that is running with enhanced security, you must answer Yes to the question about locking the domain name and authorized servers (the `ybind -S` option). For a master server, the server is bound to itself by default.

---

- Run NIS with the `-ypset` option or the `-ypsetme` option.

The `-ypset` option allows a user logged in as root on any system in your domain to bind your system to a particular server. The `-ypsetme` option allows `ybind` to accept `-ypset` requests only from the local system. For security purposes, it is best to disallow all `ypset` requests.

- Create and distribute Automount or AutoFS maps.

The `automount` and `autofs` daemons, which are alternatives to mounting remote file systems in the `/etc/fstab` file, allow users to mount remote file systems on an as-needed basis. When you use NIS to distribute the maps for these daemons, you create the maps on the NIS master server and distribute them to NIS slave servers and clients. For information on creating these maps, see Appendix A. For information on administering the maps, see Section 4.1.2.

Whether or not you use Automount or AutoFS depends on your site's networking environment.

#### Slave name

The name of each slave server in the domain.

#### IP address

The IP address of each slave server in the domain.

### 3.2.2.2 Slave Server

#### Setup options

The list of setup options for slave servers is as follows. Write the options you want to use in the appropriate place in the worksheet.

- Maintain base or enhanced security versions of the NIS maps.  
Tru64 UNIX security can be configured in either base or enhanced authentication mode. Enhanced security includes an additional `prpasswd` map that contains extended user profile information. Before configuring NIS to distribute this `prpasswd` map, read Chapter 12 of the *Security* manual. It describes important operational differences and additional steps necessary for NIS configuration in a secure environment.
- Maintain NIS maps in `btree` format.  
If you serve very large maps, you might want NIS to maintain these maps as `btree` files, which significantly reduces the time required to push very large maps. However, it might degrade performance slightly for relatively small maps. See `btree(3)` for more information about the `btree` format.  
If you intend to use enhanced security with NIS, it is best to maintain your maps in `btree` format.
- Run the `ybind` daemon with the `-s` option, which requires the server to use a reserved port.  
For security purposes, it is best to run NIS with the `-s` option.
- Lock the `ybind` daemon to a particular domain name and server list by using the `-S` option.  
Normally, hosts broadcast NIS requests on the network and the first available server answers the request. The `-s` option allows you to lock the `ybind` daemon to a particular domain and set of servers. Requests are made directly to the specified servers, rather than being broadcast. For security purposes, it is best to run NIS with the `-S` option.  
If you choose to run NIS with the `-S` option, you must know the host names and IP addresses of the servers to which you are locking the `ybind` daemon to successfully complete the configuration process.

---

#### Security Note

---

When using the `nissetup` script to set up an NIS server that is running with enhanced security, you must answer **Yes** to the question about locking the domain name and authorized servers (the `ybind -S` option). For a slave server, the server is bound to itself by default and optionally to the master server and any other slave servers.

---

- Run NIS with the `-ypset` option or the `-ypsetme` option.

The `-ypset` option allows a user logged in as root on any system in your domain to bind your system to a particular server. The `-ypsetme` option allows `ypbind` to accept `-ypset` requests only from the local system. For security purposes, it is best to disallow all `ypset` requests.

- Distribute Automount or AutoFS maps.

The `automount` and `autofs` daemons, which are alternatives to mounting remote file systems in the `/etc/fstab` file, allow users to mount remote file systems on an as-needed basis. When you use NIS to distribute the maps for these daemons, you can configure the slave server to receive the maps from the master server, distribute them to clients, and use them to mount remote file systems. For information on creating these maps, see Appendix A. For information on administering the maps, see Section 4.1.2.

Whether or not you use Automount or AutoFS depends on your site's networking environment.

### **Master name**

The host name of the master server in your domain.

### **IP address**

The IP address of the master server in your domain.

### **Slave name**

The name of another slave server in your domain. Specify several servers.

### **IP address**

The IP address of a slave server in your domain.

## **3.2.2.3 Client**

### **Setup options**

The list of setup options for clients is as follows. Write the options you want to use in the appropriate place in the worksheet.

- Run the `ypbind` daemon with the `-s` option, which requires the server to use a reserved port.  
For security purposes, it is best to run NIS with the `-s` option.
- Lock the `ypbind` daemon to a particular domain name and server list by using the `-S` option.

Normally, hosts broadcast NIS requests on the network and the first available server answers the request. The `-s` option allows you to lock the `ybind` daemon to a particular domain and set of servers. Requests are made directly to the specified servers, rather than being broadcast. For security purposes, it is best run NIS with the `-s` option.

If you choose to run NIS with the `-s` option, you must know the host names and IP addresses of the servers to which you are locking the `ybind` daemon to successfully complete the configuration process.

- Run NIS with the `-ypset` option or the `-ypsetme` option.

The `-ypset` option allows a user logged in as root on any system in your domain to bind your system to a particular server. The `-ypsetme` option allows `ybind` to accept `-ypset` requests only from the local system. For security purposes, it is best to disallow all `ypset` requests.

- Use Automount or AutoFS and the associated maps.

The `automount` and `autofs` daemons, which are alternatives to mounting remote file systems in the `/etc/fstab` file, allow users to mount remote file systems on an as-needed basis. When you use NIS to distribute the maps for these daemons, you can configure clients to receive the maps from the NIS master and slave servers and use the maps to mount remote file systems. For information on creating these maps, see Appendix A. For information on administering the maps, see Section 4.1.2.

Whether or not you use Automount or AutoFS depends on your site's networking environment.

### Server name

The name of a master or slave server in your domain. Specify several servers.

## 3.3 Configuring NIS

Use the SysMan Menu application of the Common Desktop Environment (CDE) Application Manager to configure NIS on master servers, slave servers, and clients. To invoke the SysMan Menu application, follow the instructions in Section 1.2.1.



### 3.3.1 Configuring an NIS Master Server

You must configure the NIS master server before you configure the other systems. Prior to using the SysMan Menu or the `nissetup` script, you must log in as root and complete the following tasks:

1. Copy into the `/var/yp/src` directory the local `/etc` files that you intend to make into NIS maps for distribution. If a file is absent from the `/var/yp/src` directory while it is building the default NIS maps, the `nissetup` script issues an informational message that it could not find that particular file and continues building the maps.

---

#### Note

---

If you copied the `passwd` file into the `/var/yp/src` directory, remove the root entry from the file.

---

2. Optionally, create the `/var/yp/src/mail.aliases` file. If you already have a `/var/adm/sendmail/aliases` file on your local system, you can copy it to the `/var/yp/src` directory and edit it, if necessary. For information on the format of this file, see `aliases(4)`.
3. Optionally, create the `/var/yp/src/netgroup` file. For information on the format of this file, see `netgroup(4)`.
4. Edit the `/var/yp/Makefile` file.

If you are using the NIS master server to serve the `/etc/auto.master` and `/etc/auto.home` maps for Automount or AutoFS, you must remove the comment sign (`#`) from the beginning of each of the following lines. These lines were added to the Makefile for use by the `automount` and `autofs` daemons.

```

:
:
#all: passwd group hosts networks rpc services protocols netgroup \
#   aliases auto.home auto.master
:
:
#$(YPBDDIR)/$(DOM)/auto.home.time: $(DIR)/auto.home
#   -@if [ -f $(DIR)/auto.home ]; then \
#       $(SED) -e "/^#/d" -e s/#.*$$// $(DIR)/auto.home | \
#       $(MAKEDBM) -a $(METHOD) - $(YPBDDIR)/$(DOM)/auto.home; \
#       $(TOUCH) $(YPBDDIR)/$(DOM)/auto.home.time; \
#       $(ECHO) "updated auto.home"; \
#       if [ ! $(NOPUSH) ]; then \
#           $(YPPUSH) auto.home; \
#           $(ECHO) "pushed auto.home"; \
#       else \
#           : ; \
#       fi \
#   else \
#       $(ECHO) "couldn't find $(DIR)/auto.home"; \
#   fi
#
```

```

#$(YPDBDIR)/$(DOM)/auto.master.time: $(DIR)/auto.master
#
#   -@if [ -f $(DIR)/auto.master ]; then \
#       $(SED) -e "/^#/d" -e s/#.*$$// $(DIR)/auto.master | \
#       $(MAKEDEB) -a $(METHOD) - $(YPDBDIR)/$(DOM)/auto.master; \
#       $(TOUCH) $(YPDBDIR)/$(DOM)/auto.master.time; \
#       $(ECHO) "updated auto.master"; \
#       if [ ! $(NOPUSH) ]; then \
#           $(YPPUSH) auto.master; \
#           $(ECHO) "pushed auto.master"; \
#       else \
#           : ; \
#       fi \
#   else \
#       $(ECHO) "couldn't find $(DIR)/auto.master"; \
#   fi
#
#
#auto.home: $(YPDBDIR)/$(DOM)/auto.home.time
#auto.master: $(YPDBDIR)/$(DOM)/auto.master.time
#
#$(DIR)/auto.home:
#$(DIR)/auto.master:

```

Place a comment sign (#) in front of the following lines:

```

all: passwd group hosts networks rpc services protocols netgroup \
aliases

```

If you are using the NIS master server to serve other site-specific maps, you must add entries for the maps to the Makefile. See Section 3.4.8.1 for information on adding entries for site-specific NIS maps, other than the `/etc/auto.master` and `/etc/auto.home` maps, to the `/var/yp/Makefile` file.

5. Copy the `auto.master` and `auto.home` maps, or any other site-specific maps, to the `/var/yp/src` directory. For information on creating Automount or AutoFS maps, see Appendix A. For information on creating other site-specific maps, see the Section 3.4.8.1.

To continue to set up the master server, invoke the SysMan Menu as documented in Section 1.2.1 and do the following:

1. From the SysMan Menu, select **Networking→Additional Network Services→Configure Network Information Service (NIS)**. SysMan Menu invokes the `nissetup` script.

Alternatively, enter the following command on a command line:

```
# /usr/bin/sysman nis
```

A message reminds you that your network must be established before setting up NIS, and that in order to set up an NIS server you must have the Additional Networking Services subset installed.

2. Enter `c` to continue.

3. Press Return following the script's explanation of `nissetup`, and then press Return again after the script explains the three types of systems in an NIS domain.
4. Enter and confirm your system's case-sensitive NIS domain name.
5. Choose option 1 to indicate that you are configuring the master server.
6. Following the `nissetup` script's explanation that there can be only one master server configured for each NIS domain, enter `c` and indicate whether or not you want to run the `yppasswdd` daemon. It is best to run the `yppasswdd` daemon on the NIS master server.
7. Indicate whether or not you intend to use enhanced security with NIS.
8. Indicate whether or not you want your NIS maps to be maintained as `btree` files.
9. Enter the names of hosts that will be slave servers for this domain. If you enter a host name that is not listed in the master server's `/etc/hosts` file, the `nissetup` script prompts you for its IP address.

```
Enter the names of the SLAVE servers in the test_domain domain.
Press Return to terminate the list.
```

```
Host name of slave server: host2
Host name of slave server: host3
Cannot find host3 in the file /etc/hosts.
To add host3 to the /etc/hosts file you MUST
know host3's Internet (IP) address.

Would you like to add host3 to the /etc/hosts file
(y/n) [y]? y

What is host3's Internet (IP) address [no default] ?
120.105.1.28

Is 120.105.1.28 correct (y/n) [no default] ? y

Hostname of slave server: Return
```

The `nissetup` script displays the list of servers that you entered. You can redo the list to correct errors or continue with the setup procedure.

The `nissetup` script then creates the default NIS maps, displaying messages similar to the following as it does:

```
Creating default NIS maps. Please wait...
updated passwd
updated group
updated hosts
updated networks
updated rpc
updated services
updated protocols
updated netgroup
Finished creating default NIS maps.
```

10. Indicate whether or not you want to use the `-s` security option.

If you choose to run NIS with the `-s` option, the `ybind` process runs in a secure mode. It is best to use this option.

11. Indicate whether or not you want to use the `-S` security option.

It is best to use this option. If you choose to run NIS with the `-S` option, you must enter the names of up to four NIS servers.

If you enter the name of a server that is not listed in the system's `/etc/hosts` file, the `nissetup` script prompts you for its IP address. When you are done entering the list of servers, press Return on a blank `Server n name` field and enter `c` to continue configuring NIS on your system.

12. Indicate whether or not you want to allow `ypset` requests on your system.

It is best to disallow all `ypset` requests. Press Return to accept the default, and confirm your choice.

13. Indicate whether or not you want your system to use all of the NIS databases served by the master server.

It is best to use all of the NIS databases.

If you choose to use all of the NIS databases, the `nissetup` script edits the `/etc/svc.conf` file to include the string `yp` for each database. It also edits the `/etc/passwd` and `/etc/group` files to include a plus sign followed by a colon (`+:`) at the end of each file. This enables your system to use NIS for each database listed. This symbol enables the files to be distributed by NIS. Continue with step 16.

If you choose not to use all of the NIS databases, enter `n` and continue with the next step.

14. Indicate whether or not you want to add a plus sign followed by a colon (`+:`) to the end of the local `/etc/passwd` or `/etc/group` files.

For your system to use the NIS-served `passwd` database, `group` database, or both, `+:` must be the last line in the file or files you want served by NIS. This applies to the `passwd` and `group` databases only.

---

**Note**

---

The service order selection for the `passwd` and `group` databases is handled by the Security Integration Architecture (SIA). If BSD is selected for `passwd` and `group` information in the `/etc/sia/matrix.conf` file, only the `+:` is required for your system to search NIS.

---

15. Indicate whether or not you want the `nissetup` script to invoke the `svcsetup` script.

If you answer yes, the `nissetup` script invokes the `svcsetup` script, which allows you to modify the database services selection file (the `svc.conf` file). See Section 3.3.4 for information on modifying the `svc.conf` file.

If you answer no, the `nissetup` script continues. You must edit the `svc.conf` file later if you want your system to use NIS to obtain database information other than `passwd` and `group` information.

16. Indicate whether or not to start the NIS daemons automatically.

If you answer yes, `nissetup` starts the daemons.

If you answer no, use the following command to start the daemons manually after `nissetup` exits and returns you to the system prompt (`#`):

```
# /sbin/init.d/nis start
```

### 3.3.2 Configuring a Slave Server

To configure a slave server, invoke the SysMan Menu as documented in Section 1.2.1 and do the following:

1. From the SysMan Menu, select `Networking→Additional Network Services→Configure Network Information Service (NIS)`. SysMan Menu invokes the `nissetup` script.

Alternatively, enter the following command on a command line:

```
# /usr/bin/sysman nis
```

2. A message reminds you that your network must be established before setting up NIS, and that in order to set up an NIS server you must have the Additional Networking Services subset installed. Enter `c` to continue.
3. Press Return following the script's explanation of `nissetup`, and then press Return again after the script explains the three types of systems in an NIS domain.
4. Enter and confirm your system's case-sensitive NIS domain name.
5. Choose option 2 to indicate that you are configuring a slave server.
6. Enter `c` to continue following the `nissetup` script's explanation that the master server's list must include each slave server, and that the master server must be established in order for maps to be copied to the slave server.
7. Enter the name of the master server for your domain.

8. Indicate whether or not you intend to use enhanced security with NIS.
9. Indicate whether or not you want your NIS maps to be maintained as btree files.

After you indicate your choice, the script copies the default NIS maps from the master NIS server.

10. Indicate whether or not you want to use the `-s` security option.

If you choose to run NIS with the `-s` option, the `ypbind` process runs in a secure mode. It is best to use this option.

11. Indicate whether or not you want to use the `-S` security option.

It is best to use this option. If you choose to run NIS with the `-S` option, you must enter the names of up to four NIS servers.

If you enter the name of a server that is not listed in the system's `/etc/hosts` file, the `nissetup` script prompts you for its IP address. When you are done entering the list of servers, press Return in a blank `Server n` name field and enter `c` to continue configuring NIS on your system.

12. Indicate whether or not you want to allow `ypset` requests on your system.

It is best to disallow all `ypset` requests. Press Return to accept the default and confirm your choice.

13. Indicate whether or not you want your system to use all of the NIS databases served by the master server.

It is best to use all of the NIS databases.

If you choose to use all of the NIS databases, the `nissetup` script edits the `/etc/svc.conf` file to include the string `yp` for each database. It also edits the `/etc/passwd` and `/etc/group` files to include a plus sign followed by a colon (`+:`) at the end of each file. This enables your system to use NIS for each database listed. This symbol enables the file to be distributed by NIS. Continue with step 16.

If you choose not to use all of the NIS databases, enter `n` and continue with the next step.

14. Indicate whether or not you want to add `+:` to the end of the local `/etc/passwd` or `/etc/group` files.

For your system to use the NIS-served `passwd` database, `group` database, or both, `+:` must be the last line in the file or files you want NIS to serve. This applies to the `passwd` and `group` databases only.

---

### Note

---

The service order selection for the `passwd` and `group` databases is handled by the Security Integration Architecture (SIA). If BSD is selected for `passwd` and `group` information in the `/etc/sia/matrix.conf` file, the `+` is required only for your system to search NIS.

---

15. Indicate whether or not you want the `nissetup` script to invoke the `svcsetup` script.

If you answer yes, the `nissetup` script invokes the `svcsetup` script, which allows you to modify the database services selection file (the `svc.conf` file). See Section 3.3.4 for information on modifying the `svc.conf` file.

If you answer no, the `nissetup` script continues. You must edit the `svc.conf` file later if you want your system to use NIS to obtain database information other than `passwd` and `group` information.

16. Indicate whether or not to start the NIS daemons automatically.

If you answer yes, `nissetup` starts the daemons.

If you answer no, use the following command to start the daemons manually after `nissetup` exits and returns you to the system prompt (`#`):

```
# /sbin/init.d/nis start
```

### 3.3.3 Configuring an NIS Client

To configure an NIS client, invoke the SysMan Menu as documented in Section 1.2.1 and do the following:

1. From the SysMan Menu, select Networking→Additional Network Services→Configure Network Information Service (NIS). SysMan Menu invokes the `nissetup` script.

Alternatively, enter the following command on a command line:

```
# /usr/bin/sysman nis
```

2. A message reminds you that your network must be established before setting up NIS, and that in order to set up an NIS server you must have the Additional Networking Services subset installed. Enter `c` to continue.
3. Press Return following the script's explanation of `nissetup`, and then press Return again after the script explains the three types of systems in an NIS domain.
4. Enter and confirm your system's case-sensitive NIS domain name.

5. Press Return to accept the default that you are configuring a client.
6. Enter `c` to continue following the `nissetup` script's warning that at least one server must be configured for this domain.
7. Indicate whether or not you want to use the `-s` security option.  
If you choose to run NIS with the `-s` option, the `ypbind` process runs in a secure mode. It is best to use this option.
8. Indicate whether or not you want to use the `-S` security option.  
It is best to use this option. If you choose to run NIS with the `-S` option, you must enter the names of up to four NIS servers.  
If you enter the name of a server that is not listed in the system's `/etc/hosts` file, the `nissetup` script prompts you for its IP address. When you are done entering the list of servers, press Return in a blank `Server n` name field and enter `c` to continue configuring NIS on your system.
9. Indicate whether or not you want to allow `ypset` requests on your system.  
It is best to disallow all `ypset` requests. Press Return to accept the default, and confirm your choice.
10. Indicate whether or not you want your system to use all of the NIS databases served by the master server.  
It is best to use all of the NIS databases.  
If you choose to use all of the NIS databases, the `nissetup` script edits the `/etc/svc.conf` file to include the string `yp` for each database. It also edits the `/etc/passwd` and `/etc/group` files to include a plus sign followed by a colon (`+:`) at the end of each file. This enables your system to use NIS for each database listed. This symbol enables the file to be distributed by NIS. Continue with step 13.  
If you choose not to use all of the NIS databases, enter `n` and continue with the next step.
11. Indicate whether or not you want to add `+:` to the end of the local `/etc/passwd` or `/etc/group` files.  
For your system to use the NIS served `passwd` database, `group` database, or both, `+:` must be the last line in the file or files you want served by NIS. This applies to the `passwd` and `group` databases only.

---

**Note**

---

The service order selection for the `passwd` and `group` databases is handled by the Security Integration Architecture (SIA). If BSD is selected for password and group information



in the `/etc/sia/matrix.conf` file, the `+` is required only for your system to search NIS.

---

12. Indicate whether or not you want the `nissetup` script to invoke the `svcsetup` script.

If you answer yes, the `nissetup` script invokes the `svcsetup` script, which allows you to modify the database services selection file (the `svc.conf` file). See Section 3.3.4 for information on modifying the `svc.conf` file.

If you answer no, the `nissetup` script continues. You must edit the `svc.conf` file later if you want your system to use NIS to distribute database information other than password and group information.

13. Indicate whether or not to start the NIS daemons automatically.

If you answer yes, `nissetup` starts the daemons.

If you answer no, use the following command to start the daemon manually after `nissetup` exits and returns you to the system prompt (`#`):

```
# /sbin/init.d/nis start
```

### 3.3.4 Modifying the `svc.conf` File with `svcsetup`

If you choose not to use NIS for all of the default databases, you can edit the `/etc/svc.conf` file with the `svcsetup` script. If you answer yes when `nissetup` asks if you want to run `svcsetup`, it invokes the `svcsetup` script. Use the following procedure to edit the `/etc/svc.conf` file:

1. Press Return to choose the `m` option from the Configuration Menu.
2. Enter the numbers from the Change Menu that correspond to the databases whose entries you want to modify.
3. Enter the number that corresponds to the order in which you want to query the services on your system.

If you choose the default (2), the local `/etc` files are searched first for the requested information. If the information is not found locally, then an NIS server is queried. This choice is valid for all of the databases that NIS serves.

To have NIS serve `hosts` information if your system is also having `hosts` information served by DNS, choose either option 5 (`local,bind,yp`) or option 6 (`bind,local,yp`) for the `hosts` database. Note that options 3 (`local,bind`), 4 (`bind,local`), 5, and 6 are valid for the `hosts` database only.

### 3.3.5 Modifying or Removing an NIS Configuration

If you configure NIS and run the `nissetup` script, you can modify or remove the NIS configuration.

If you choose to modify the NIS configuration, the `nissetup` script proceeds as described in Section 3.3.1 to Section 3.3.3, resulting in a new configuration.

If you choose to remove the NIS configuration, the `nissetup` script prompts you to verify your choice, then removes the NIS information from the following files:

- `/etc/rc.config.common`
- `/etc/passwd`
- `/etc/group`
- `/etc/svc.conf`
- `/var/yp/DOMAIN` (where *DOMAIN* is the name of the current NIS domain)

This directory and its contents are deleted (for NIS master and slave servers only).

## 3.4 Managing an NIS Server

This section describes how to perform the following NIS server tasks:

- Add an NIS slave server to a domain
- Remove an NIS slave server from a domain
- Add a user to an NIS domain
- Update an NIS map
- Add an NIS map to a domain
- Remove an NIS map from a domain
- Modify the `/var/yp/Makefile` file
- Restrict access to NIS data

### 3.4.1 Adding an NIS Slave Server to a Domain

Adding a slave server to a domain enables the slave server to receive updated NIS maps from the master server and serve them to NIS clients in a domain.

To add an NIS slave server to a domain, do the following:

1. Set up the system as a slave server. See Section 3.3.2 for information on setting up a slave server.

2. Log in to the NIS master server as root.
3. Change to the `/var/yp` directory by using the `cd` command.
4. Undo the `ypservers` map and direct the output to a file by using the following command:
 

```
# makedbm -u domainname/ypservers > filename
```
5. Edit the file and add the host name of the slave server.
6. Build a new `ypservers` map by using the `makedbm` command as follows:
 

```
# makedbm filename ypservers
```

You can combine steps 4, 5, and 6 into one command line. See the example at the end of this procedure.
7. Move the `ypservers.dir` and `ypservers.pag` map files to the domain subdirectory.
8. Distribute the updated `ypservers` map to the slave servers by using the `yppush` command.
9. Edit the NIS master server's master `hosts` file and add an entry for the slave server, if it is not already in the `hosts` file. Then update the map by entering the `make` command. The `make` command also distributes the updated map.

See `makedbm(8)` for more information on building maps.

The following example (illustrating steps 3 through 9) shows how to add slave server `host8` to domain `market`:

```
# cd /var/yp
# /var/yp/makedbm -u market/ypservers ; echo host8\ [1]
|/var/yp/makedbm - tmpmap
# mv tmpmap.dir market/ypservers.dir [2]
# mv tmpmap.pag market/ypservers.pag
# yppush ypservers [3]
# vi /var/yp/src/hosts [4]
:
# make hosts [5]
```

- [1] Represents the combination of steps 4, 5, and 6 in the preceding procedure. The output from the `makedbm` command with the `-u` option is displayed and the new server name, `host8`, is echoed on standard output to add it to the file. Then, the output is piped back into the `makedbm` command to build a new map named `tmpmap`.

---

### Note

---

You can type these lines as one command even if the command wraps on your screen, or you can use the backslash escape character (`\`), as shown.

---

- ❷ Moves the `tmpmap.dir` and `tmpmap.pag` map files to the domain `market` subdirectory and renames them as `ypservers` map files.
- ❸ Distributes the updated map to the slave servers.
- ❹ Adds a new host to the `hosts` NIS map on the master server.
- ❺ Updates the map and distributes the updated map to the slave servers.

Section B.1 contains a sample script you can copy that performs the steps involved in adding a slave server to a domain. You still have to set up the slave server and edit the master server's `hosts` file, adding a slave server entry, if necessary.

## 3.4.2 Removing an NIS Slave Server from the Domain

Removing a slave server from a domain means that the system will no longer receive updated NIS maps from the master server and serve them to NIS clients in a domain.

To remove an NIS slave server from the domain, do the following:

1. Log in to the NIS slave server.  
If the system will be an NIS client, configure it as an NIS client by using `nissetup`. See Section 3.3.3 for more information.  
If the system will no longer use NIS, disable NIS in the `/etc/rc.config.common` file by using the following command:  

```
# /usr/sbin/rcmgr -c set NIS_CONF NO
```
2. Log in to the NIS master server as `root`.
3. Change to the `/var/yp` directory by using the `cd` command.
4. Undo the `ypservers` map and direct the output to a file by using the following command:  

```
# makedbm -u ypservers > filename
```
5. Edit the file and remove the host name of the slave server.
6. Build a new map by using the `makedbm` command as follows:  

```
# makedbm filename ypservers
```

You can combine steps 4, 5, and 6 into one command line. See the example following this procedure.

7. Move the `ypservers.dir` and `ypservers.pag` map files to the domain subdirectory.
8. Distribute the updated `ypservers` map to the slave servers by using the `yppush` command.

See `makedbm(8)` for more information on building maps.

The following example (illustrating steps 4 through 8) shows how to remove slave server `host4` from domain `market`:

```
# cd /var/yp
# /var/yp/makedbm -u market/ypservers | \ [1]
  grep -v host4 | /var/yp/makedbm - tmpmap
# mv tmpmap.dir market/ypservers.dir [2]
# mv tmpmap.pag market/ypservers.pag
# yppush ypservers [3]
```

- [1] Represents the combination of steps 4, 5, and 6 in the preceding procedure. The output from the `makedbm` command with the `-u` option is piped into `grep` with the `-v` option to display all lines except the one containing the slave server name (`host4`). Then, the output is piped back into the `makedbm` command to build a new map named `tmpmap`.

---

**Note**

---

You can type these lines as one command even if the command wraps on your screen, or you can use the backslash escape character (`\`), as shown.

---

- [2] Moves the `tmpmap.pag` and `tmpmap.dir` map files to the domain `market` subdirectory and renames them as `ypservers` map files.
- [3] Distributes the updated map to the slave servers.

Section B.2 contains a sample script you can copy that performs the steps involved in removing a slave server from a domain. You still have to reconfigure the slave server as an NIS client or as a system that does not use NIS.

### 3.4.3 Adding a New User to an NIS Domain

Adding a new user to an NIS domain adds the user's account information to the `passwd` map and allows the user to participate in the NIS environment. A user has only one password on all systems that use NIS for their `passwd` map.

To add a new user to an NIS domain, invoke the SysMan Menu on the NIS master server, as documented in Section 1.2.1, and do the following:

1. From the SysMan Menu, select Accounts→Manage NIS Users to display the Manage NIS Users dialog box.

Alternatively, enter the following command on a command line:

```
# /usr/bin/sysman nis_users
```

2. Select Add to display the Add a User dialog box.
3. Enter the user name, user ID, and password for the new user.
4. Select a primary group for the user:
  - a. Select Choose to open the Primary Group dialog box.
  - b. Select one group from the list of groups. Then, select OK to close the Primary Group dialog box.
5. Enter a secondary group for the user, if necessary.
6. Select a shell for the user.
  - a. Select Choose to open the Shells dialog box.
  - b. Select a shell from the pull-down menu. Then, select OK to close the Primary Group dialog box.
7. Deselect the Create Home Directory check box if you do not want the system to create a home directory for the user. By default, the system creates a directory for the user in the `/usr/users` directory.

If you choose to allow the system to create the user's home directory, you can specify an alternate location for the directory in the Home Directory field.
8. Enter comments for the account, if necessary. For example, at a college, you could use this field to indicate that a new account is temporary for a visiting professor.
9. Deselect the Lock Account check box to unlock the account. Unlocking the account gives the user permission to log in and use the account.
10. Select OK to create the user's account. You are informed that the account has been created. Select OK to dismiss the confirmation message and to close the Add a User dialog box.
11. Select Exit to close the Manage NIS Users dialog box.
12. Create the user's home directory if you did not allow the utility to create it for you. Then, set up the user's environment. See the *System Administration* manual for more information.

You can also modify and delete NIS user accounts with the SysMan Menu. See the online help for more information.

If you prefer, you can use the `dxaccounts` or `useradd` utilities to administer NIS users. See the online help and `useradd(8)` for more information.

### 3.4.4 Adding a New Group to an NIS Domain

Adding a group to an NIS domain adds the group and all of its registered users to the `group` map. To add a new group to an NIS domain, invoke the SysMan Menu on the NIS master server, as documented in Section 1.2.1, and do the following:

1. From the SysMan Menu, select `Accounts→Manage NIS Groups` to display the `Manage NIS Groups` dialog box.

Alternatively, enter the following command on a command line:

```
# /usr/bin/sysman nis_groups
```

2. Select `Add` to display the `Add a Group` dialog box.
3. Enter the group name and group ID for the new group.
4. Select one or more users who will be in the group from the `Members` list.
5. Select `OK` to create the group. You are informed that the group has been created. Select `OK` to dismiss the confirmation message and to close the `Add a Group` dialog box.
6. Select `Exit` to close the `Manage NIS Groups` dialog box.

You can also modify and delete NIS groups with the SysMan Menu. See the online help for more information.

If you prefer, you can use the `dxaccounts` or `groupadd` utilities to administer NIS groups. See the online help and `groupadd(8)` for more information.

### 3.4.5 Updating an NIS Map

Updating an NIS map involves making changes to an NIS map's master file, updating the `Makefile` file (if the map is not listed), and building and distributing the new map. Entries for the following standard maps are included in the `Makefile` file:

- `passwd`
- `group`
- `hosts`
- `networks`

- `rpc`
- `services`
- `protocols`
- `netgroup`
- `aliases` (`mail.aliases`)

The master files are located in the `/var/yp/src` directory on the NIS master server.

To update an NIS map, do the following:

1. Log in to the NIS master server as `root`.
2. Change to the `/var/yp` directory by using the `cd` command.
3. Modify the `Makefile` file, if no entry exists in the `/var/yp/Makefile` file for the map you want to update.  
See Section 3.4.8 for information on modifying the `Makefile` file.
4. Change to the `/var/yp/src` directory by using the `cd` command.
5. Edit the master file of the map you want to update and make your changes.
6. Change to the `/var/yp` directory by using the `cd` command.
7. Update and distribute the map by using the `make` command as follows:

```
# make map_name
```

The following example (illustrating steps 4 through 7) shows how to update the `hosts` map:

```
# cd /var/yp/src [1]
# vi hosts [2]
:
# cd /var/yp [3]
# make hosts [4]
```

- [1] Changes to the `/var/yp/src` directory.
- [2] Opens the `/var/yp/src/hosts` file for editing.
- [3] Changes to the `/var/yp` directory.
- [4] Updates the map and distributes it to the slave servers.

### 3.4.6 Adding an NIS Map to a Domain

Adding an NIS map to a domain allows the database information to be distributed throughout an NIS domain. You can create and distribute maps for any information you want to distribute.



To add an NIS map to a domain, do the following:

1. Log in to the NIS master server as root.
2. Create a master file for your new map.  
A master file is an ASCII text file containing individual entries. Each entry has fields separated by spaces. Some of these fields are used to build a key to each entry. Review some of the master files in the `/var/yp/src` directory to better understand the structure of a master file.
3. If you are using NIS to distribute NFS Automount or AutoFS maps, create a file named `auto.master` in the `/var/yp/src` directory. If the file exists, add an entry for the map you want to distribute.  
See Section 4.1.2 and Appendix A for more information on the `auto.master` map.
4. Edit `/var/yp/Makefile` file to include the new map in the default set of maps.  
See Section 3.4.8 for information on modifying the `Makefile` file.
5. Change to the `/var/yp` directory by using the `cd` command.
6. Update the map by using the `make` command as follows:

```
# make map_name
```

The following example adds the `phonelist` map to a domain:

```
# vi /var/yp/src/phonelist [1]
:
# vi /var/yp/Makefile [2]
:
# cd /var/yp [3]
# make phonelist [4]
```

- [1] Creates a `phonelist` master file on the master server.
- [2] Opens the `Makefile` file for editing.
- [3] Changes to the `/var/yp` directory.
- [4] Updates the map and distributes the updated map to the slave servers.

### 3.4.7 Removing an NIS Map from a Domain

Removing an NIS map from a domain prevents the database information from being distributed throughout an NIS domain.

To remove an NIS map from a domain, do the following:

1. Log in to the NIS master server as root.

2. If you are using NIS to distribute NFS Automount or AutoFS maps, delete the entry for the map you no longer want distributed from the `auto.master` file in the `/var/yp/src` directory.

See Section 4.1.2 and Appendix A for more information on the `auto.master` map.

3. Edit the `/var/yp/Makefile` file to remove the map from the default set of maps.

See Section 3.4.8 for information on modifying the `Makefile` file.

### 3.4.8 Modifying the `/var/yp/Makefile` File

Modifying the `Makefile` file means adding or deleting database entries in the `/var/yp/Makefile` file on the NIS master server. By adding a database entry to the `Makefile` file, you indicate that you want a map produced for the specific database when you use the `make` command. By deleting a database entry, you indicate that you do not want a map produced for the specific database.

As you edit the `/var/yp/Makefile` file, remember the following:

- The order of entries in the line that begins with `all:` is not important. However, in continuation lines, the blank space preceding the line must be a tab character; do not use spaces.
- Variables are defined at the top of the `Makefile` file.

#### 3.4.8.1 Adding an Entry

To add an entry to the `Makefile` file, do the following:

1. Log in to the NIS master server as root.
2. Edit the `/var/yp/Makefile` file and add the database name to the line beginning with `all:`. Next, add a line with the following format to the end of the file:

```
database_name:database_name.time
```

Finally, add an entry with the following format to the middle of the file:

```
database_name.time: various_commands
```

To simplify the creation of this entry, copy the `auto.home.time: entry` in the file and make the necessary database name changes.

3. If you are using NIS to distribute NFS Automount or AutoFS maps, uncomment any line that contains the `auto.master` string by deleting the comment character (`#`) that precedes it.

The following example shows the `phonelist` database added to the `/var/yp/Makefile` file. There is a tab character preceding the `netgroup` database name in the `all:` line.

```
all: passwd group hosts networks rpc services protocols \
    netgroup aliases phonelist
    :
$(YPDBDIR)/$(DOM)/phonelist.time: $(DIR)/phonelist
    -@if [-f $(DIR)/phonelist ]; then \
        $(SED) -e "/^#/d" -e s/#.*$$// $(DIR)/phonelist | \
        $(MAKEDBM) -a $(METHOD) - $(YPDBDIR)/$(DOM)/phonelist; \
        $(TOUCH) $(YPDBDIR)/$(DOM)/phonelist.time; \
        $(ECHO) "updated phonelist"; \
        if [ ! $(NOPUSH) ]; then \
            $(YPPUSH) phonelist; \
            $(ECHO) "pushed phonelist"; \
        else \
            : ; \
        fi \
    else \
        $(ECHO) "couldn't find $(DIR)/phonelist"; \
    fi
    :
phonelist: phonelist.time
```

### 3.4.8.2 Deleting an Entry

To delete an entry from the `Makefile` file, do the following:

1. Log in to the NIS master server as `root`.
2. Edit the `/var/yp/Makefile` file, delete the database name from the line beginning with `all:`, and delete the line beginning with the database name (`database_name:`).

Instead of deleting the database line, you can comment out the line by adding a comment character (`#`) to the beginning of the line.

### 3.4.9 Restricting Access to NIS Data

By default, the `ypserv` and `ypxfrd` daemons provide NIS information to anyone with network access to an NIS server who makes a request. However, you can restrict NIS database access to only those hosts in subnets you specify by completing the following steps:

1. Log in to the NIS server as `root`.
2. Create a `/var/yp/securenets` file.

3. Edit the `/var/yp/securenets` file and add an entry for each subnet from which the NIS server is to accept NIS requests. The format of each file entry is as follows:

```
subnet_mask subnet_ip_address
```

For example:

```
255.255.0.0 128.30.0.0 1  
255.255.255.0 128.211.10.0 2  
255.255.255.255 128.211.5.6 3
```

- 1** Allows IP addresses that are within the subnet 128.30 range to access the NIS files. The network mask is 255.255.0.0 and the corresponding network address is 128.30.0.0.
- 2** Allows IP addresses that are within the subnet 128.211.10 range to access the NIS files.
- 3** Allows one host with the IP address 128.211.5.6 to access the NIS files.

4. Save the file.

If the file does not exist or contains no entries, the server accepts any NIS request.

If the file exists and contains entries, the `ypserv` and `ypxfrd` daemons read the `/var/yp/securenets` file during initialization. When an NIS request is received, the requester's IP address is compared to the subnets in the `/var/yp/securenets` file. If it matches, the request is processed. If it does not match, NIS silently discards the request. No message is logged (because malicious users could use these messages to fill up a system's disk).

On the system making the NIS request, NIS commands such as `ypcat` terminate with no error message. If a user is trying to log in to a system, the login times out after many retries.

---

**Note**

---

If the `/var/yp/securenets` file is modified, you must kill and restart the `ypserv` and `ypxfrd` daemons.

---

You can also use a `/var/yp/securenets` file to restrict access to NIS data on a slave server. However, the NIS slave server's IP address must be in the authorization range of entries in the `/var/yp/securenets` file of the NIS master.

## 3.5 Managing an NIS Client

This section describes how to perform the following NIS client management tasks:

- Change an NIS password
- Obtain NIS map information

### 3.5.1 Changing an NIS Password

To change a user's password in the NIS `passwd` map, use the `yppasswd` command. If you receive an error message, ask the system administrator on the master server to verify that the `rpc.yppasswdd` daemon on the NIS master server is running.

If you try to change an NIS-distributed password with the `passwd` command, you receive the following error message:

```
Not in passwd file.
```

The root password is local and not in the NIS file. To change the root password, use the `passwd` command.

See `yppasswd(1)` and `rpc.yppasswdd(8)` for further information.

### 3.5.2 Obtaining NIS Map Information

NIS map information includes the following:

- Map names
- Map values
- Map keys
- Map master server

To obtain NIS map information, issue one of the commands listed in Table 3-1.

**Table 3-1: NIS Map Information Commands**

| Command              | Action   |
|----------------------|--|
| <code>ypcat</code>   | Prints values from an NIS database                                       |
| <code>ypwhich</code> | Prints the name of the host that is the current NIS server or map master |
| <code>ypmatch</code> | Prints the values of one or more keys from an NIS map                    |

Use the `-x` option with any of the commands shown in Table 3-1 to list all the map nicknames.

See `ypcat(1)`, `ypwhich(1)`, and `ypmatch(1)` for more information about these commands.

The following command lists all available maps and their master servers:

```
# ypwhich -m
```

The following command lists all values in the `hosts` map:

```
# ypcat hosts
```

The following command lists all occurrences in the `hosts` map that have the key `apple`:

```
# ypmatch apple hosts
```

The following command lists all occurrences in the `hosts` map that have the name `jones` associated with them. The name `jones` is not a key in this map.

```
# ypcat hosts | grep jones
```

# 4

---

## Network File System

The Network File System (NFS) is a facility for sharing files in a heterogeneous environment. This chapter describes:

- The NFS environment (Section 4.1)
- How to plan for your NFS configuration (Section 4.2)
- How to configure NFS servers and clients (Section 4.3)
- How to deconfigure NFS servers and clients (Section 4.4)
- How to manage an NFS server (Section 4.5)
- How to manage an NFS client (Section 4.6)

For introductory information on NFS, see `nfs_intro(7)`. For troubleshooting information, see Section 9.8 for clients and Section 9.7 for servers.

### 4.1 NFS Environment

In the NFS environment, systems can have the following roles:

- Client — A system that imports file systems. A client can mount file systems by using either the `/etc/fstab` file or an automatic mounting daemon, such as the `automount` or `autofs` daemons. All methods are explained in this chapter.
- Server — A system that exports file systems.

Your system can be set up as an NFS server, a WebNFS server, an NFS client, or all three.

#### 4.1.1 Distributing the hosts Database

If your network is running the Network Information Service (NIS) or the Domain Name System (DNS) to distribute host information, you do not need to list each server that is referenced in a client's `/etc/fstab` file in the client's local `/etc/hosts` file. However, the server's host information must be in the NIS or DNS database.

Similarly, if your network is running NIS or DNS to distribute host information and the client information is listed in the `hosts` database, you do not have to list each client that is referenced in a server's `/etc/exports` file in the server's local `/etc/hosts` file.

## 4.1.2 Automatic Mounting Daemons

The `automount` and `autofs` daemons offer alternatives to mounting remote file systems with the `/etc/fstab` file, allowing you to mount them on an as-needed basis.

When a user on a system running one of these daemons invokes a command that must access a remotely mounted file or directory, the daemon mounts that file system or directory and keeps it mounted for as long as the user needs it. When a specified amount of time elapses (the default is 5 minutes) without the file system or directory being accessed, the daemon unmounts it.

You specify the file systems to be mounted in map files. These maps can be customized to suit your environment and are administered in the following ways:

- Use NIS to create and distribute the maps
- Administer the maps locally
- Use a combination of both methods

See Appendix A for information on creating these maps. With a few restrictions, as documented in the Restrictions section of `autofs`(8), Automount and AutoFS maps can be used interchangeably.

---

### Note

---

The Automount daemon will be retired in a future release of the operating system. For information about migrating from Automount to AutoFS, see Section 4.6.2.4.

---

### 4.1.2.1 Serving Automount and AutoFS Maps with NIS

NIS allows you to create and distribute customized Automount and AutoFS maps. When NIS is used to distribute maps, the administrator of the NIS master server creates and administers the maps for the NIS domain. In this case, you must configure each system that uses Automount or AutoFS as an NIS client so that it can receive the maps.

If many clients in an environment remotely mount the same file system by specifying it in their `/etc/fstab` file, that file system is a good candidate for inclusion in a map distributed by NIS. Carefully constructed maps can allow client systems to eliminate a large part of their `/etc/fstab` files. If the location of a file system that is included in a distributed map changes, or its server changes, the administrator changes the map on the NIS master server. The change is then propagated throughout the domain without users on the client systems having to edit their `/etc/fstab` files.



See Section 3.3.1 for information on configuring a master NIS server to serve maps.

#### 4.1.2.2 Local Automount and AutoFS Maps

Local Automount and AutoFS maps might be useful to you under the following circumstances:

- Your system mounts remote file systems that are not typically mounted by other NIS clients.
- Your network is not running NIS.
- You need to test a map.

Administering the `automount` or `autofs` daemons locally is the same as administering them when NIS distributes the maps, except that you, as administrator of your system, create and manage the maps.

A local `auto.master` map serves the same function as one distributed in an NIS domain. If you specify a local `auto.master` map, the daemon consults it for the location of other maps, their local mount points, and the mount options. You can use an `auto.master` map that is distributed by NIS, a local `auto.master` map, both, or neither, if the selected daemon is invoked correctly.

#### 4.1.2.3 WebNFS

WebNFS is an NFS protocol that allows clients to access files over the Internet in the same way that local files are accessed. WebNFS uses a public file handle that allows it to work across a firewall. This public file handle also reduces the amount of time required to initialize a connection. The public file handle is associated with a single directory (`public`) on the WebNFS server. See `exports(4)`, `exportfs(2)`, and `nfs_intro(4)` for further information.

## 4.2 Planning NFS

Figure 4–1 shows the NFS Setup Worksheet, which you can use to record the information required to configure NFS. If you are viewing this manual online, you can use the print feature to print a copy of this worksheet. The following sections explain the information you need to record on the worksheet.

**Figure 4–1: NFS Setup Worksheet**

| NFS Setup Worksheet          |   |                              |                          |
|------------------------------|---|------------------------------|--------------------------|
| <b>Server</b>                | Number of nfsd threads: TCP: _____ UDP: _____<br>Property lists: <input type="checkbox"/> Yes <input type="checkbox"/> No<br>NFS locking: <input type="checkbox"/> Yes <input type="checkbox"/> No<br>PC-NFS daemon: <input type="checkbox"/> Yes <input type="checkbox"/> No<br>Allow nonroot mounts: <input type="checkbox"/> Yes <input type="checkbox"/> No<br>Address verification: <input type="checkbox"/> Yes <input type="checkbox"/> No |                              |                          |
| <b>Exported directories:</b> |   |                              |                          |
| Path name:                   | Permissions:  | Network group/<br>Node name: |                          |
|                              |   |                              |                          |
|                              |   |                              |                          |
|                              |   |                              |                          |
|                              |   |                              |                          |
|                              |   |                              |                          |
| <b>Client</b>                | Number of I/O threads: _____<br>NFS locking: <input type="checkbox"/> Yes <input type="checkbox"/> No<br>Automatic mounting daemon: <input type="checkbox"/> Automount <input type="checkbox"/> AutoFS <input type="checkbox"/> None  |                              |                          |
| <b>Imported directories:</b> |   |                              |                          |
| Path name:                   | Remote server name:   | Local mount point:           | RO:                      |
|                              |   |                              | <input type="checkbox"/> |
|                              |   |                              | <input type="checkbox"/> |
|                              |   |                              | <input type="checkbox"/> |
|                              |   |                              | <input type="checkbox"/> |
|                              |   |                              | <input type="checkbox"/> |

## 4.2.1 Server

### Number of nfsd threads

Enter the number of `nfsd` TCP and UDP server threads to run. These threads service requests from NFS clients. The default number of 8 is adequate for an average work load. You can configure a combined total of 0 to 128 TCP and UDP server threads.

On systems that support Cache Coherent NUMA, the number of threads is per Resource Affinity Domain (RAD). See `nfsd(8)` and `numa_intro(3)` for more information.

## **Property lists**

If you want to run the property list daemon, check Yes; otherwise, check No. The property list daemon allows the server to handle requests to get, set, or delete the property lists associated with NFS-served file system objects. See `proplistd(8)` and `proplist(4)` for more information.

## **NFS locking**

If you want to run the NFS lock manager (`rpc.lockd`) and status monitor (`rpc.statd`), check Yes. Running these daemons allows users to use the `fcntl` and `lockf` functions to lock file regions on NFS files (in addition to local files). If you do not run these daemons, users can use advisory locking primitives only on local files. For more information on the `fcntl` and `lockf` functions, see `fcntl(2)` and `lockf(3)`.

## **PC-NFS daemon**

If you want to run the PC-NFS daemon (`rpc.pcnfsd`), check Yes; otherwise, check No. The PC-NFS daemon allows the server to handle NFS requests from PCs.

## **Allow nonroot mounts**

If you allow nonroot mounts, users on client systems who do not have root privileges can still mount the file systems or directories exported from this system. If you do not allow nonroot mounts, only the superusers on the client systems can mount file systems from this host. The default setting does not allow nonroot mounts.

## **Address Verification**

If you want the server to verify the Internet address of any host that requests an exported directory, check Yes; otherwise, check No. If you choose Yes and you also want to verify that the host is in the server's domain or subdomain, check Domain Checking, Subdomain Checking, or both.

### **4.2.1.1 Exported Directories**

Use the following fields to define file systems that your server will export to client systems:

#### **Path name**

The path name of the file systems or directories that you intend to export.

## Permissions

The permissions to assign for each exported file system or directory. You can specify whether a file system or directory is exported with read-write (rw) or read-only (ro) permission, and you can map client superuser access to a root user ID (UID) number other than the default of -2. If you have a WebNFS server with the `-public` option set, the mount access list is ignored by the server so that all hosts using the WebNFS protocol have access to this directory. For more information on assigning permissions to exported file systems or directories and on specifically mapping the root UID for clients, see `exports(4)`.

## Network group/Node name

The network groups or individual host names to which you will export these file systems or directories. For information on defining network groups, see `netgroup(4)`.

If you want to limit the hosts that can import a file system or directory, you must explicitly specify the individual hosts or network groups in the `/etc/exports` file. If you do not specify individual hosts or network groups, all hosts can import that file system or directory.

If you are exporting a file system to a client that has multiple network interfaces on a subnet, you must specify the host names for all of the interfaces; otherwise, export requests from the unspecified interfaces will be denied. See *Network Administration: Connections* for more information about multiple interfaces in a subnet and connection balancing.

## 4.2.2 Client

### Number of I/O threads

The number of I/O threads to run. The default number of 7 is recommended for optimum load generation on servers. You can configure from 0 to 64 `nfsiod` threads.

In addition, you can start `nfsiod` threads from the command line. See `nfsiod(8)` for information on starting `nfsiod` threads from the command line.

### NFS locking

If you want to run the NFS lock manager (`rpc.lockd`) and status monitor (`rpc.statd`), check Yes. Running these daemons allows users to use the `fcntl` and `lockf` functions to lock file regions on NFS files (in addition to local files). If you do not run these daemons, users can

use advisory locking primitives only on local files. For more information on the `fcntl` and `lockf` functions, see `fcntl(2)` and `lockf(3)`.

### **Automatic mounting daemon**

If the client is to run an automatic mounting daemon, such as Automount or AutoFS, check the box for one of these daemons; otherwise, check None.

You can select only one automatic mounting daemon. While AutoFS provides higher efficiency and availability than Automount, there are some restrictions for its use. See the Restrictions sections of `autofs(8)` and `autofs(8)` for more information.

If the network is running the NIS, the Automount or AutoFS maps are better administered and served from the NIS master server. The format of the maps is the same whether they are local or served by the NIS master server. For information on creating maps, see Appendix A.

#### **4.2.2.1 Imported Directories**

Use the following fields to define the remote file systems that your client will import:

##### **Path name**

The complete pathnames of the file systems or directories that you want to import.

##### **Remote server name**

The host names of the servers from which you are importing file systems or directories.

##### **Local mount point**

The mount point on the local system where you want the imported file systems or directories to reside.

##### **RO (Read-only)**

The permissions for the imported file systems or directories. Check the box for a read-only mount. Leave the box unchecked for a read-write mount.

---

##### **Note**

---

If you mount your user area from a server, make sure that your UID on the client is the same as your UID on the server. NFS uses your client UID to check against file

access permissions on the server. If your UID is different on the client and server, you cannot modify your own NFS mounted files (assuming that you have the permissions on the mounted files set so that only you can modify them). Since the server does the access checking, the only UID allowed to modify the files is the one that the server knows.

---

## 4.3 Configuring NFS

Use the SysMan Menu application of the Common Desktop Environment (CDE) Application Manager to configure NFS on clients and servers. To invoke the SysMan Menu application, follow the instructions in Section 1.2.1.

### 4.3.1 Configuring an NFS Server

To configure an NFS server, complete the following steps. If you want your system to import file systems, see Section 4.3.2 for information on configuring an NFS client.

1. From the SysMan Menu, select Networking→Additional Network Services→Network File System (NFS)→Configure system as an NFS server to display the Configure NFS Server dialog box.

Alternatively, enter the following command on a command line:

```
# /usr/bin/sysman nfs_server
```

2. Enter the number of server TCP threads to be run in the appropriate field.
3. Enter the number of server UDP threads to be run in the appropriate field.
4. Select the Enable Property List Daemon check box if you want to run the property list daemon (`proplistd`).
5. Deselect the Enable Locking check box if you do not want to run the NFS lock manager (`rpc.lockd`) and status monitor (`rpc.statd`) daemons. Locking is enabled by default.
6. Select the Enable PC-NFS Daemon check button if you want to run the `rpc.pcnfsd` daemon.

If you run the PC-NFS daemon, you must export to the client the directories you want to mount on the PC client. To enable the client to utilize network printing, you must export the `/usr/spool/pcnfs` directory to the PC client. For information on exporting directories, see Section 4.5.2.

7. Select the Allow Nonroot Mounts check box if you want to allow users other than root to mount file systems.
8. Deselect the Internet Address Verification check box if you do not want the `mountd` daemon to verify the IP address of each host requesting a mount or unmount. Internet Address Verification is enabled by default.
9. Select the Internet Address Verification & Domain Checking check box to have the `mountd` daemon verify that the host requesting a mount or unmount is in the server's domain.
10. Select the Internet Address Verification & Subdomain Checking check box to have the `mountd` daemon verify that the host requesting a mount or unmount is in the server's subdomain.
11. Specify the directories you want to export by following steps 2 through 7 in Section 4.5.2.
12. Select OK to validate your changes. The utility prompts you to start the NFS daemons.
13. Select Yes to save your configuration, start the daemons, and apply the changes immediately; or select No to save your configuration, close the Configure NFS Server dialog box, and apply the changes the next time you reboot your system.

If you choose Yes, you are informed that the NFS daemons have been started. Select OK to dismiss the message and to close the Configure NFS Server dialog box.

You can also modify or deconfigure your server configuration after the initial setup. See the online help and Section 4.4 for more information.

### 4.3.2 Configuring an NFS Client

To configure an NFS client, do the following:

1. From the SysMan Menu, select Networking→Additional Network Services→Network File System (NFS)→Configure system as an NFS client. The Configure NFS Client dialog box is displayed.

Alternatively, enter the following command on a command line:

```
# /usr/bin/sysman nfs_client
```

2. Enter the number of client I/O threads to be run in the appropriate field.
3. Select the Enable Locking check box to specify locking configuration if the status of the `lockd` daemon is Stopped. If the status of the daemon is Running, locking is already set.
4. Select the Enable Automount Daemon check box to configure the `automount` daemon. See Section 4.1.2 for information on Automount

and Appendix A for information on Automount maps. If you would like to configure the AutoFS daemon, see Section 4.6.2.2 for more information.

5. Enter appropriate arguments to the automount daemon in the Automount Arguments field. See Section 4.6.2.3 for more information.
6. Specify the directories you want to import, those not already imported by automount, by following steps 2 through 10 in Section 4.6.1.
7. Select OK to validate the changes. (Due to the myriad of automount arguments available to the user, the validation of these arguments is deferred until the automount daemon starts and verifies them.)

You are asked if you would like to start or restart the NFS daemons.

8. Select Yes to save the configuration, start the daemons, and apply your changes immediately; or select No to save the configuration, close the Configure NFS Client dialog box, and apply the changes the next time you reboot your system.

If you choose Yes, you are informed that the NFS daemons have been started. Select OK to dismiss the message and to close the Configure NFS Client dialog box.

You can also modify or deconfigure your client configuration after the initial setup. See the online help and Section 4.4 for more information.

## 4.4 Deconfiguring NFS

You can use the SysMan Menu to deconfigure NFS servers and clients. When you deconfigure an NFS server or an NFS client, the corresponding NFS daemons stop and all of the corresponding NFS configuration information is deleted from the system. This action cannot be undone. To restore your NFS server or client, you must configure it again using the SysMan Menu.

When you deconfigure an NFS server, the client services are not removed. Likewise, when you deconfigure an NFS client, the server configuration is not removed. If you would like to deconfigure both the client and server configurations on a system, you must perform each action independently.

To deconfigure an NFS server, select Deconfigure system as an NFS Server from the SysMan Menu, or enter the following command on the command line:

```
# /usr/sbin/sysman nfs_deconfig_server
```

To deconfigure an NFS client, select Deconfigure system as an NFS Client from the SysMan Menu, or enter the following command on the command line:

```
# /usr/sbin/sysman nfs_deconfig_client
```



For both client and server, the Deconfigure NFS dialog box is displayed. Select Yes to deconfigure the service. You are informed that the service has been deconfigured. Select OK to dismiss the message and to close the dialog box.

## 4.5 Managing an NFS Server

This section describes how to perform the following NFS server tasks:

- Export a directory or file system
- Halt export of a directory or file system
- Enable a superuser on a client system to access files as superuser
- Send mail to superuser (root) across NFS
- Enable port monitoring
- Monitor the NFS load

### 4.5.1 Export Guidelines

The `/etc/exports` file defines an export list for each file system and directory that a client can mount. When creating entries in the `/etc/exports` file, remember the following:

- Make only one entry for each exported file system or directory; multiple entries are not supported.
- Each entry exports that directory and all subdirectories in it, except for those subdirectories that reside in a file system (disk partition) different from the exported directory.
- File systems and directories are exported with read-write access by default.
- If no remote system (client) names are specified for a file system or directory, any client on the network can mount that file system or directory.
- If one or more client names are specified for a file system or directory, only those clients can mount the exported file system or directory.
- If you are exporting a file system to a client that has multiple network interfaces on a subnet, you must specify the host names for all of the interfaces.
- If you start the `mountd` daemon with the `-i` option, only those hosts in the server's host database are allowed mount access. If you start the `mountd` daemon with the `-d` or `-s` option, only those clients in the same domain or subdomain, respectively, are allowed mount access.

- Exporting specific directories to specific clients provides more security than does exporting an entire file system to all clients.
- Protect sensitive exported data on the server by making the data files owned and accessible only by root, and do not allow superusers on client systems root access over NFS.
- The `-public` option can be specified by only one exported file system.

## 4.5.2 Exporting a File System or Directory

Exporting a file system or directory makes it available for client systems on the network to mount remotely. If you want your system to be an NFS server and to export file systems and directories, be aware that your system will be less secure. However, depending on how you export your files, you can minimize the security risks.

To export a file system by using the SysMan Menu, do the following:

1. From the SysMan Menu, select **Networking**→**Additional Network Services**→**Network File System (NFS)**→**Configure system as an NFS server** to display the **Configure NFS Server** dialog box.

Alternatively, enter the following command on a command line:

```
# /usr/bin/sysman nfs_server
```

2. Select the **Shared Local Directories** button to display the **Share Local Directory** dialog box.
3. Select **Add** to add a shared directory. The **Add/Modify** dialog box is displayed.
4. Enter the full path name of the directory to be exported in the **Share this Directory** field.
5. Select whether the directory has **read/write** or **read-only** access and whether all hosts or only selected hosts can have access. By default, the directory is exported with **read/write** permissions to all hosts.  
If you choose **Selected** in either the **Read/Write** or **Read-Only** dialog box, enter the name of each host that can have access to this directory in the appropriate field. Select **Add** for each host.
6. Select **OK** to validate the entry and to close the **Add/Modify** dialog box. Repeat steps 3 through 6 for additional directories.
7. Select **OK** to save the list of directories you chose to export in the `/etc/exports` file. You are informed that the changes have been made. Select **OK** to dismiss the message and to close the **Share Local Directory** dialog box.
8. Select **OK** to close the **NFS Server** dialog box.

You can also modify and delete exported directories with the Share Local Directory dialog box. See Section 4.5.3 and the online help for more information.

Optionally, you can use a text editor to add, modify, and delete exported directories directly in the `/etc/exports` file. See `exports(4)` for more information about editing this file.

### 4.5.3 Halting Export of a Directory or File System

Halting export of a directory or file system prevents client systems from accessing the particular directory or file system; you can still export other directories or file systems. If you do not want to export any file systems, you might want to deconfigure your NFS server as documented in Section 4.4.

To halt the export of a file system by using the SysMan Menu, do the following:

1. From the SysMan Menu, select **Networking**→**Additional Network Services**→**Network File System (NFS)**→**Configure system as an NFS server** to display the **Configure NFS Server** dialog box.

Alternatively, enter the following command on a command line:

```
# /usr/bin/sysman nfs_server
```

2. Select the **Shared Local Directories** button to display the **Share Local Directory** dialog box.
3. Select the entry that you no longer want to export from the list of shared directories.
4. Select **Delete** to remove the highlighted entry from the list. Repeat steps 3 and 4 to halt the export of additional entries.
5. Select **OK** to save the remaining list of exports in the `/etc/exports` file. You are informed that the changes have been made. Select **OK** to dismiss the message and to close the **Share Local Directory** dialog box.
6. Select **OK** to close the **NFS Server** dialog box.

You can also add and modify exported directories with the Share Local Directory dialog box. See Section 4.5.2 and the online help for more information.

Optionally, you can use a text editor to add, modify, and delete exported directories directly in the `/etc/exports` file. See `exports(4)` for more information about editing this file.

## 4.5.4 Enabling Client Superuser Access to Files

By default under NFS, a superuser (root) on a client system does not have superuser privileges on the server and cannot do the following:

- Access remotely mounted files and directories whose permissions do not allow world access
- Change the ownership of remotely mounted files (run the `chown` command)

For security reasons, it is best not to allow a remote superuser access to your system as superuser unless both the remote host and superuser are trusted. However, in a friendly network environment, you can explicitly allow superuser access over the network.

To allow a superuser on a client access to your server system, edit the `/etc/exports` file on your server and add the `-root=0` option to the entry you want to make available. The `-root=0` option maps the remote superuser's identification to UID 0. All future mount requests will be honored with root mapping. By default, this option allows superuser access from any client system on the network. To restrict the superuser access to specific systems, use the `-root=host_list` option, where `host_list` is a list of host names. See `exports(4)` for more information.

By default, NFS servers regard superusers and those users without UNIX authentication (personal computer systems) as anonymous users. This class of users can only access files that are accessible to the world. To prevent anonymous users from accessing file systems or directories, use the `-anon=-1` option. If you still want to allow client superusers access to the file systems or directories, specify the `-root` option in addition to the `-anon` option. The `-root` option overrides the `-anon` option for client superusers only.

A superuser on a client system can assume the identity of any other user on the client system by substituting the UID number. The client superuser could then have the access rights of another user on the server. Therefore, to protect sensitive exported data on the server, make root the owner of the data files and do not export the directory or file system with root mapping. This is useful if you need to export other files in the file system.

The following example shows entries in an `/etc/exports` file:

```
/usr/games -root=0 host8 1  
/usr/templates -root=host8 2
```

- 1** Exports the `/usr/games` file system. It can be mounted remotely (read-write) only by the client system `host8`. However, the client superuser has superuser access to the file system. The superuser's UID is 0 (zero).

- 2 Exports the `/usr/templates` file system. It can be mounted remotely (read-write) by any client in the network. However, only the superuser on `host8` has superuser access to the file system.

## 4.5.5 Sending Mail to Superuser (root) Across NFS

If the `/usr/spool/mail` directory is remotely mounted from the server, and the directory is not exported with the `root=0` option, client users will not be able to send mail to the superuser (`root`) on the server. To enable clients to send mail to `root`, set the `root` and `admin` aliases to the login name or names of the system administrators for that system. Then, users can address all mail intended for the administrators of that system as follows:

```
admin@system
```

To enable clients to send mail to `root`, follow these steps:

1. Edit the `/var/adm/sendmail.cf` file and add the alias name `admin` to the following line:

```
CN MAILER-DAEMON postmaster
```

The resulting line will look like the following line:

```
CN MAILER-DAEMON postmaster admin
```

This adds the name `admin` to the class `N`.

Alternatively, you can run the Mail Configuration application and add `admin` as a local user. See Chapter 7 for more information.

2. Edit the `/var/adm/sendmail/aliases` file, add the login names of the system administrators, and redefine (alias) the name `root` to be `admin`.
3. Restart the `sendmail` daemon by using the following command:

```
# /sbin/init.d/sendmail restart
```

If you are enabling clients to send mail to `root`, remember the following:

- It is best for all systems in the local area network (LAN) to follow this convention. Mail for `root` or `admin` on any system can be automatically directed to any user login on any system.
- A `/usr/spool/mail/root` mailbox is not created or used.

The following example shows the steps involved in enabling clients to send mail to `root`:

```
# vi /var/adm/sendmail/sendmail.cf 1
:
:
# vi /var/adm/sendmail/aliases 2
:
:
```

```
# /sbin/init.d/sendmail restart 3
```

- 1 Opens the `/var/adm/sendmail/sendmail.cf` file to add the admin alias.
- 2 Opens the `/var/adm/sendmail/aliases` file to add the login names and root alias.
- 3 Restarts the `sendmail` daemon.

The following example shows entries in the `/var/adm/sendmail/aliases` file for the system administrators John, Mary, and Joe:

```
admin:john,mary,joe  
root:admin
```

## 4.5.6 Enabling Port Monitoring

Only privileged users can attach to Internet domain source ports known as privileged ports. By default, NFS does not check to see if a client is bound to a privileged port. You might want to activate NFS server port monitoring to be sure that file access requests are generated by the client kernel rather than forged by an application program.

Although this operating system enforces the privileged port convention, some operating systems do not. If hosts running a different operating system are on your network, activating port checking might not improve security, but could prevent those systems from functioning properly as NFS client systems.

To start NFS server port monitoring, enter the following command:

```
# /usr/sbin/nfsportmon on
```

To stop source port monitoring, enter the following command:

```
# /usr/sbin/nfsportmon off
```

## 4.5.7 Monitoring the NFS Load

Monitoring the NFS load allows you to see the number of NFS requests, both client and server, being executed on the local machine. It is a good idea to monitor NFS requests periodically to determine whether you need additional NFS server threads.

To monitor NFS requests, use the `nfsstat` command with the following syntax:

```
nfsstat -n
```

See `nfsstat(8)` for more information on monitoring NFS load.

The following example shows the client and server activity on a local machine:

```
# /usr/bin/nfsstat -n
nfs:
calls      badcalls
69228      0

Server nfs V2:
null      getattr   setattr   root      lookup    readlink  read
1 0%      24 0%     0 0%      0 0%      60 0%     0 0%     5 0%
wrcache   write     create    remove    rename    link      symlink
0 0%      58030 83%  20 0%     0 0%      0 0%     0 0%
mkdir     rmdir    readdir   statfs
0 0%      0 0%     0 0%      2 0%
```

```
Server nfs V3:
null      getattr   setattr   lookup    access    readlink  read
0 0%      667 0%    1009 1%   2598 3%   101 0%    200 0%   1408 2%
write     create    mkdir     symlink   mknod    remove    rmdir
1280 1%   376 0%    71 0%    200 0%    0 0%     676 0%   70 0%
rename    link      readdir   readdir+  fsstat   fsinfo    pathconf
100 0%    100 0%    468 0%   0 0%     1750 2%  2 0%     0 0%
commit
10 0%
```

```
Client nfs:
calls      badcalls  nclget    nclsleep
224664     0         224664    0

Client nfs V2:
null      getattr   setattr   root      lookup    readlink  read
0 0%      51328 22%  1069 0%   0 0%     41643 18%  455 0%   28793 12%
wrcache   write     create    remove    rename    link      symlink
0 0%      64665 28%  589 0%   1052 0%  352 0%   250 0%   250 0%
mkdir     rmdir    readdir   statfs
171 0%    170 0%   2689 1%  1814 0%
```

```
Client nfs V3:
null      getattr   setattr   lookup    access    readlink  read
0 0%      2038 0%   2180 0%   8534 3%   430 0%    450 0%   3136 1%
write     create    mkdir     symlink   mknod    remove    rmdir
3158 1%   1048 0%   243 0%   450 0%    1 0%     1848 0%  242 0%
rename    link      readdir   readdir+  fsstat   fsinfo    pathconf
452 0%    350 0%   1240 0%  0 0%     3506 1%  3 0%     0 0%
commit
75 0%
```

## 4.6 Managing an NFS Client

Your system can be an NFS client if the following conditions exist:

- Your system can reach an NFS server over the network.
- Your system's host or network group name is included in the server's `/etc/exports` file, or the server is exporting a file system to all systems on the network.

This section describes how to perform the following NFS client tasks:

- Mount a remote file system or directory

- Mount a remote file system or directory with Automount or AutoFS
- Unmount a remote file system or directory

### 4.6.1 Mounting a Remote File System or Directory

You can mount a remote file system or any subdirectory within a remote file system onto a local mount point. While mounted, it is treated as a file system by the local system.

To mount a remote file system or directory by using the SysMan Menu, do the following:

1. From the SysMan Menu, select Networking→Additional Network Services→Network File System (NFS)→Configure system as an NFS client to display the Configure NFS Client dialog box.

Alternatively, enter the following command on a command line:

```
# /usr/bin/sysman nfs_client
```

2. Select the Mount Network Directories button to display the Mount Network Directory dialog box.  
A list of NFS-mounted directories that are saved in the `/etc/fstab` file is displayed. Remote file systems that you mounted by using the `mount` command are not included in this list.
3. Select Add to add a remote directory. The Add/Modify dialog box is displayed.
4. Enter the host name of the NFS server from which the remote directory is exported in the Remote Host Name field.
5. Enter the full path name of the directory to be imported in the Remote Directory Path field.
6. Enter the full path name of the local directory on which the imported directory is to be mounted in the Local Mount Point field.
7. Select whether the directory has read-only or read/write access with the appropriate radio button.
8. Select the Mount on Reboot checkbox if you want the directory to be mounted each time you reboot.
9. Select OK to validate the entry and to close the Add/Modify dialog box. Repeat steps 3 through 9 for additional directories.
10. Select OK to save the list of directories you chose to import. The names of those directories that are to be mounted on reboot are saved in the `/etc/fstab` file.

You are informed that the changes have been made. Select OK to dismiss the message and to close the Mount Network Directory dialog box.



11. Select OK to close the NFS Client dialog box.

You can also modify and delete your imported directories with the Mount Network Directory dialog box. See Section 4.6.3 and the online help for more information.

Each directory imported via the Mount Network Directory dialog box is mounted using the `bg` and `hard` options of the `mount` command. If the first attempt to mount the directory fails, the client tries mounting it in the background (`bg` option), and it continues attempting to mount the directory until the server responds (`hard` option). No other `mount` options can be selected via the dialog box.

Optionally, you can use the `mount` or `umount` commands to mount or unmount remote file systems from the command line. Or, you can use a text editor to directly add, modify, or delete entries in the `/etc/fstab` file. You would use these alternatives if you need to specify `mount` options that are not supported by the Mount Network Directory dialog box. See `mount(8)`, `umount(8)`, and `fstab(4)` for more information.

## 4.6.2 Automatically Mounting a Remote File System

The following sections describe how to configure Automount and AutoFS, two services that allow you to automatically mount a remote file system or directory at the time of access.

---

### Note

---

The Automount daemon will be retired in a future release of the operating system. For information about migrating from Automount to AutoFS, see Section 4.6.2.4.

---

Before starting the configuration procedure for either service, determine whether or not you are using local maps or NIS-distributed maps. See Section 4.1.2 for a description of local and NIS-distributed maps.

### 4.6.2.1 Using Automount to Mount a Remote File System

To use local Automount maps, do the following:

1. Log in as root.
2. Create a local `auto.master` map. You can create this and other maps in any directory on the system, but they are conventionally located in the `/etc` directory, where the SysMan Menu expects to find them.

See Appendix A for information on creating maps.

---

**Note**

---

If you are modifying an existing `auto.master` map, you must stop and restart the automount daemon to apply the revised map.

---

3. Create the local maps for your system.
4. Start the automount daemon by using the NFS Client dialog box of the SysMan Menu. See Section 4.3.2 for information on starting the automount daemon.

When the automount daemon starts, it uses the local `auto.master` file to determine the location of other maps, their local mount points, and the mount options.

To use NIS-distributed Automount maps, do the following:

1. Set up your system as an NIS client. See Section 3.3.3 for information on setting up an NIS client.
2. Start the automount daemon by using the NFS Client dialog box of the SysMan Menu. See Section 4.3.2 for information on starting the automount daemon.

The NIS master server serves all Automount maps in the domain. When the automount daemon starts, it uses the master `auto.master` file to determine the location of other maps, their local mount points, and the mount options.

If you alter your local or NIS-distributed Automount maps at any time, you must restart the automount daemon on clients as follows to apply the changes:

1. From the SysMan Menu, select **Networking**→**Additional Network Services**→**Network File System (NFS)**→**Configure system as an NFS client** to display the **Configure NFS Client** dialog box.  
Alternatively, enter the following command on a command line:  

```
# /usr/bin/sysman nfs_client
```
2. Deselect the **Enable Automount** check box.
3. Select **OK** to disable Automount and **Yes** to restart the NFS daemons. A message indicates the the daemons are restarted; select **OK** to dismiss the message and close the NFS Client dialog box.
4. Open the NFS Client dialog box again.
5. Select the **Configure for Automount** check box.

6. Select OK to enable Automount and Yes to restart the NFS daemons. A message indicates the the daemons are restarted.
7. Select OK to dismiss the message and to close the NFS Client Setup dialog box.

See `automount(8)` for information on the `automount` command and its arguments.

#### 4.6.2.2 Using AutoFS to Mount a Remote File System

To use local AutoFS maps, do the following:

1. Log in as root.
2. Create a local `auto.master` map. You can create this and other maps in any directory on the system, but they are conventionally located in the `/etc` directory.

See Appendix A for information on creating maps.

---

#### Note

---

If you are modifying an existing `auto.master` map, you must process the map with the `autofs mount` command to apply the changes.

---

3. Create the local maps for your system.
4. Start the `autofs d` daemon by entering the following command:
 

```
# /usr/sbin/autofs d &
```
5. Execute the `autofs mount` command to process your local master file:
 

```
# /usr/sbin/autofs mount -m -f local_master_file
```
6. Use the `rcmgr` utility to configure AutoFS to start each time you boot your system. The AutoFS parameters in the following steps are case sensitive and must be typed in uppercase as shown.
  - a. Enable the AutoFS daemon by entering the following command:
 

```
# rcmgr -c set AUTOFS 1
```
  - b. Specify arguments for the `autofs d` daemon and the `autofs mount` command, as follows:

```
# rcmgr -c set AUTOFSD_ARGS "arguments"
# rcmgr -c set AUTOFSMOUNT_ARGS "-m -f local_master_file"
```

You must define the `AUTOFSD_ARGS` parameter, even if you do not need to define arguments for the `autofs d` daemon. If there are no arguments, specify open and close quotation marks (`"`).

See `autofs(8)` and `autofs(8)` for information about valid arguments.

When the `autofs` command is executed, it installs intercept points into the kernel based on the maps you created. When users access the associated file systems, the kernel communicates with the `autofs` daemon to mount and unmount the file systems based on the map entries.

To use NIS-distributed AutoFS maps, do the following:

1. Set up your system as an NIS client. See Section 3.3.3 for information on setting up an NIS client.

2. Start the `autofs` daemon by entering the following command:

```
# /usr/sbin/autofs &
```

3. Use the `rcmgr` utility to configure AutoFS to start each time you boot your system. The AutoFS parameters in the following steps are case sensitive and must be typed in uppercase as shown.

- a. Enable the AutoFS daemon by entering the following command:

```
# rcmgr -c set AUTOFS 1
```

- b. Specify arguments for the `autofs` daemon and the `autofs` command, as follows:

```
# rcmgr -c set AUTOFS_ARGS "arguments"  
# rcmgr -c set AUTOFS_MOUNT_ARGS ""
```

You must define the `AUTOFS_ARGS` parameter, even if you do not need to define arguments for the `autofs` daemon. If there are no arguments, specify open and close quotation marks (`""`).

Setting the `autofs` command to run with no arguments indicates that AutoFS is to use the NIS-distributed `auto.master` file.

See `autofs(8)` and `autofs(8)` for information about valid arguments.

The NIS master server serves all AutoFS maps in the domain. When the `autofs` command is executed, it uses the master `auto.master` file to determine the location of other maps, their local mount points, and the mount options.

If you alter your local or NIS-distributed maps at any time, you must process the map with the `autofs` command to apply the changes. Note that you cannot update map entries while an active NFS file system is mounted on the designated mount point. You must unmount the NFS file system before the AutoFS mount-update takes effect.

See `autofs(8)` and `autofs(8)` for more information. See `sys_attrs_autofs(5)` for tuning information.

### 4.6.2.3 Specifying automount and autofs Arguments

You can specify arguments for the `automount` or `autofs` daemons from the command line, in a local `auto.master` map, in an NIS-distributed `auto.master` map, or some combination of the three. However, it is important to know that the daemons read and carry out their instructions in the following order:

1. Command line information, such as additional mount points or replacements to entries in a master map, are read first. Command line information takes precedence over instructions in any maps — local or NIS-distributed.
2. Instructions in a local `auto.master` map (specified with the `-f` option) are read next. The information in the local master map overrides information in an NIS-distributed master map.
3. Information in the NIS-distributed master map is read last.

When you invoke the `automount` or `autofs` commands without any arguments, they look for a distributed NIS map called `auto.master`. If they find one, the commands check the master map for information about the location of other maps, their local mount points, and the mount options. If they do not find one, and if no local `auto.master` map is specified, the commands exit.

You can pass command arguments to the `automount` daemon from the NFS Client dialog box of the SysMan Menu as documented in Section 4.3.2. You can also pass arguments to either the `automount` or `autofs` command in one of the following ways:

- Specify all of the arguments to either command on the command line. For example:

```
# automount /net -hosts \  
  /home /etc/auto.home -rw,intr \  
  /- /etc/auto.direct -ro,intr
```

- Specify all of the arguments to either command in the `rc.config.common` file by using the `rcmgr` utility. Arguments you specify in this file are passed to the command when you boot your system. For example:

```
# rcmgr -c set AUTOMOUNT_ARGS "/net -hosts \  
  /home /etc/auto.home -rw,intr \  
  /- /etc/auto.direct -ro,intr"
```

For the `autofs` command, the parameter to set is `AUTOFSMOUNT_ARGS`, as follows:

```
# rcmgr -c set AUTOFSMOUNT_ARGS "/net -hosts \  
/home /etc/auto.home -rw,intr \  
/- /etc/auto.direct -ro,intr"
```

- Include the arguments from the previous examples in an NIS-distributed `auto.master` map:

```
/net    -hosts  
/home  /etc/auto.home      -rw,intr  
/-     /etc/auto.direct    -ro,intr
```

If this NIS `auto.master` map is distributed, typing the `automount` or `autofs` command at the superuser prompt (`#`) produces the same results as the previous command line.

- Include the arguments in a local `auto.master` file and use the `-f` option to instruct the `automount` or `autofs` command to process the local `auto.master` file. The `-f` option instructs these commands to consult the local master map first and then the NIS-distributed master map. For example:

```
# automount -f /etc/auto.master
```

You can also add the `-m` option, which forces the commands to ignore the NIS-distributed master map, if there is one. For example:

```
# automount -m -f /etc/auto.master
```

- Specify mount points on the command line, in addition to those included in the local `auto.master` file. For example:

```
# automount -f /etc/auto.master \  
/src /etc/auto.src -ro,soft
```

- Nullify one of the entries in the local `auto.master` map. For example:

```
# automount -f /etc/auto.master /home -null
```

This option is currently not supported by the `autofs` command.

- Replace an entry in the local `auto.master` map with one of your own. For example:

```
# automount -f /etc/auto.master \  
/home /mine/auto.home -rw,intr
```

AutoFS provides one additional convenience for complicated configurations that require many cumbersome `autofs` arguments. It allows you specify your `autofs` arguments in an environment variable called `AUTOFSMOUNT_EXPARGS`, which is subsequently imported by the `autofs` command when you invoke it with the `-e` option. You can

arrange for this by adding the appropriate statements to the configuration file for your shell, as follows.

For C Shell (in `.cshrc` file):

```
setenv AUTOFSMOUNT_EXPARGS `rcmgr -c get AUTOFSMOUNT_ARGS`
```

For Korn Shell (in `.profile` file):

```
AUTOFSMOUNT_EXPARGS=`rcmgr -c get AUTOFSMOUNT_ARGS`  
export AUTOFSMOUNT_EXPARGS
```

With the environment variable set in this manner, you can invoke the `autofs mount` command with all of your predefined options as follows:

```
# autofs mount -e
```

If necessary, you can include additional options after the `-e` option.

See `automount(8)` and `autofs mount(8)` for more information on these commands and their arguments.

#### 4.6.2.4 Migrating from Automount to AutoFS

Automount will be retired in a future release; therefore, if you are using Automount, you will eventually need to migrate to AutoFS. If you want to migrate now, you can use the instructions in this section to complete the task. (If your system is a node in a cluster, see the *TruCluster Server Release Notes* for information about migrating from Automount to AutoFS in a cluster environment.)

There are two procedures for migrating from Automount to AutoFS. The primary difference between the procedures is that the first one requires you to reboot the operating system, and the second one allows the system to remain in multi-user mode. The first procedure is recommended because it is less complicated and it ensures that all automounted file systems will be cleanly unmounted, but the second procedure is provided as an alternative for high-availability systems that cannot be rebooted.

It is recommended that you familiarize yourself with AutoFS by reading Section 4.1.2, Section 4.6.2, `autofs d(8)`, and `autofs mount(8)` before proceeding with these migration steps.

Note that Automount and AutoFS maps are compatible, with the few exceptions that are mentioned in the Restrictions section of `autofs mount(8)`.

#### 4.6.2.4.1 Recommended Migration Path

To migrate from Automount to AutoFS on a system that can be rebooted, do the following:

1. Determine the arguments that you must pass to the `autofs` command at boot time. See the `autofs` reference page for a list of valid options and arguments.

Note that these arguments are typically a subset of those you have already specified for the `automount` daemon in the `AUTOMOUNT_ARGS` parameter of the `/etc/rc.config.common` file. To view that parameter, execute the following command:

```
# /usr/sbin/rcmgr -c get AUTOMOUNT_ARGS
```

To set the corresponding arguments for the `autofs` command, define the `AUTOFSMOUNT_ARGS` parameter as follows:

```
# /usr/sbin/rcmgr -c set AUTOFSMOUNT_ARGS "arguments"
```

2. Determine the arguments that you must pass to the `autofs` daemon at boot time. See the `autofs` reference page for a list of valid options and arguments.

These arguments are typically any environment variable definitions (`-D` option) that you have already specified for the `automount` daemon in the same `AUTOMOUNT_ARGS` parameter that was mentioned in step 1.

To set the corresponding arguments for the `autofs` daemon, define the `AUTOFS_ARGS` parameter as follows:

```
# /usr/sbin/rcmgr -c set AUTOFS_ARGS "arguments"
```

If you have not defined any environmental variables with the `automount` daemon, it is possible that there will be no `autofs` arguments. In this case, you must specify the `AUTOFS_ARGS` parameter with open and close quotation marks (“”).

3. Disable Automount and enable AutoFS in the `/etc/rc.config.common` file by entering the following commands:

```
# /usr/sbin/rcmgr -c set AUTOMOUNT 0  
# /usr/sbin/rcmgr -c set AUTOFS 1
```

These values specify that AutoFS will be the only automatic mounting service in effect when the system boots.

4. Reboot the system to put the new AutoFS configuration into effect.

Note that Automount will remain fully functional until you reboot. Do not attempt to start AutoFS while Automount is running.



#### 4.6.2.4.2 High-Availability Migration Path

To migrate from Automount to AutoFS on a system that cannot be rebooted, do the following:

1. Follow steps 1-3 in Section 4.6.2.4.1.
2. Release all auto-mounted file systems by eliminating their use.  
In terminal windows, if you are operating in an automounted file system, change directory into another file system. If you have any files open in an automounted file system, close the files and, if necessary, close any applications that might have a lock on these files.
3. Stop the `automount` daemon.
  - a. Determine the process IDs of all Automount tasks by entering the following command:  

```
# ps -ef | grep automount
```
  - b. Stop each Automount process by entering the following command:  

```
# kill -SIGTERM process-ID
```
4. Verify that automounted file systems are no longer mounted by entering the following command:  

```
# /sbin/mount -e | grep temporary_mount_dir
```

Replace `temporary_mount_dir` with the name of the directory in which Automount temporarily mounts file systems. By default, this directory is `tmp_mnt`.

This command searches for instances of `temporary_mount_dir` in the current list of all mount points. If any such mount points still exist, they will still be usable under their `temporary_mount_dir` pathnames, but they will no longer be usable via the expected pathnames under which they were served by Automount. If these mount points later become idle, you can remove them by entering the following command:  

```
# /sbin/umount -f mount-point
```

None of these mounts will affect AutoFS, because AutoFS does not use a temporary mount directory.
5. Start the AutoFS service with the arguments you previously specified in the `/etc/rc.config.common` file.
  - a. Start the `autofs` daemon, as follows:  

```
# /usr/sbin/autofs arguments
```

To display the arguments you already defined for `autofs`, enter the following command:

```
# /usr/sbin/rcmgr -c get AUTOFSD_ARGS
```

- b. Invoke the `autofs` command, as follows:

```
# /usr/sbin/autofs mount arguments
```

To display the arguments you already defined for `autofs`, enter the following command:

```
# /usr/sbin/rcmgr -c get AUTOFSMOUNT_ARGS
```

If you properly set the AutoFS arguments in the `/etc/rc.config.common` file, you will not need to start AutoFS in this manner again. It will automatically start each time that you boot the operating system.

### 4.6.3 Unmounting a Remote File System or Directory

Unmounting a remote file system or directory removes access to a particular file system or directory that is being imported from an NFS server; you can still import other directories or file systems. If you do not want to import any file systems, you might want to deconfigure your NFS client as documented in Section 4.4.

To unmount a remote file system or directory by using the SysMan Menu, do the following:

1. From the SysMan Menu, select **Networking**→**Additional Network Services**→**Network File System (NFS)**→**Configure system as an NFS client** to display the **Configure NFS Client** dialog box.

Alternatively, enter the following command on a command line:

```
# /usr/bin/sysman nfs_client
```

2. Select the **Mount Network Directories** button to display the **Mount Network Directory** dialog box.

A list of NFS-mounted directories that are saved in the `/etc/fstab` file is displayed. Remote file systems that you mounted by using the `mount` command are not included in this list. Use the `umount` command to unmount these file systems. See `umount(8)`.

3. Select the entry that you want to unmount from the list.
4. Select **Delete** to remove the highlighted entry from the list. Repeat steps 3 and 4 to remove additional entries
5. Select **OK** to save the current list of imported directories in the `/etc/fstab` file.

You are informed that the changes have been made. Select **OK** to dismiss the message and to close the **Mount Network Directory** dialog box.

6. Select **OK** to close the **NFS Client** dialog box.

You can also add and modify your imported directories with the Mount Network Directory dialog box. See Section 4.6.1 and the online help for more information.

Optionally, you can use the `mount` or `umount` commands to mount or unmount remote file systems from the command line. Or, you can use a text editor to directly add, modify, or delete entries in the `/etc/fstab` file. See `mount(8)`, `umount(8)`, and `fstab(4)` for more information.



---

## UNIX-to-UNIX Copy Program

The UNIX-to-UNIX Copy Program (UUCP) is a group of programs that enables batched, error-free file transfer and remote command execution between two UNIX systems. UUCP is typically used to transfer electronic mail, network nets, and public domain software over low-speed, low-cost communications links. Tru64 UNIX implements the HoneyDanBer version of UUCP.

This chapter describes:

- The UUCP environment (Section 5.1)
- How to plan for your UUCP configuration (Section 5.2)
- How to configure your system for UUCP (Section 5.3)
- How to manage UUCP (Section 5.4)

For general information about UUCP see `uucp_intro(7)`. For information on how to use UUCP, see the *Command and Shell User's Guide*.

For troubleshooting information, see Section 9.9.

### 5.1 UUCP Environment

In the UUCP environment, systems can be connected to each other in the following ways:

- Directly connected to each other, if they are in close proximity
- Connected through modems and a telephone network, if they are not in close proximity
- Connected through a local area network (LAN), if they are not in close proximity

Figure 5–1 shows two simple UUCP configurations. Figure 5–2 shows a sample UUCP configuration on a LAN in which Host A has a TCP/IP connection with Host C.

**Figure 5–1: Sample Simple UUCP Configuration**

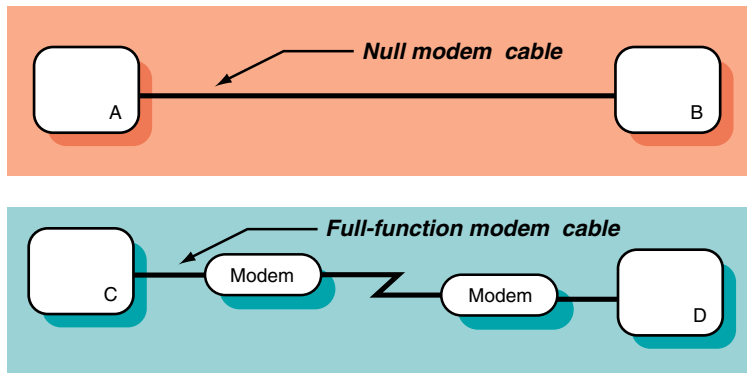

ZK-1174U-AI

**Figure 5–2: Sample UUCP Over TCP/IP Configuration**

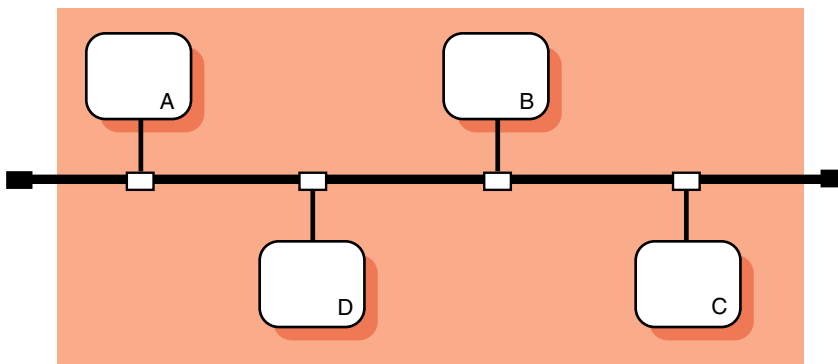

ZK-1175U-AI

## 5.2 Planning UUCP

This section describes those tasks you need to do before configuring UUCP.

### 5.2.1 Verifying the Correct Hardware

In verifying the correct hardware, you need to verify both the cables and modems, if used.

Make sure you are using the correct cable to connect to the serial port of your system. If you do not, you might experience signal degradation and the software will fail to function properly.

See the Point-to-Point Connections chapter in *Network Administration: Connections* for a list of modem cables to use. If the two systems are in close proximity to each other, use one of the null modem cables. If the two systems are connected through modems and telephone lines, use a standard modem cable. When using modems with UUCP, make sure that both the local and the remote modems are correctly configured.

UUCP can also be configured to run over TCP/IP local area networks (LANs). For information on running UUCP over a LAN, see `uucp_manual_setup(7)`.

## 5.2.2 Preparing for the Configuration

UUCP configuration consists of defining the following parts:

- Connection information for your system
- Dial-up information for outgoing calls
- Information for receiving incoming calls

The type of information you need depends on the types of connections you plan to set up and use. The following sections contain worksheets that you can use to record the information required to configure UUCP.

### 5.2.2.1 Information for Connections

Figure 5-3 shows the UUCP Setup Worksheet. If you are viewing this manual online, you can use the print feature to print a copy of the worksheet. The sections that follow explain the information you need to record on the worksheet.

**Figure 5–3: UUCP Setup Worksheet**

---

**UUCP Setup Worksheet**

---

**Type of connection:**     Modem     Direct link     TCP/IP

**Modems:**

    Modem type: \_\_\_\_\_

    Baud rate: \_\_\_\_\_     Any

    Device name: \_\_\_\_\_

    /etc/inittab entry ID: \_\_\_\_\_

**Direct links:**

Remote system name: \_\_\_\_\_     Direct

    Baud rate: \_\_\_\_\_     Any

    Device name: \_\_\_\_\_

    /etc/inittab entry ID: \_\_\_\_\_

**TCP/IP:**

Outgoing connections:     Yes     No

Incoming connections:     Yes     No

---

**Type of connection**

The types of connections you want to configure. You can configure one or all of the following connections:

- Modems — Modems enable you to use UUCP over analog transmission facilities, which include telephone lines.
- Direct (hardwired) links — Direct hardwired links connect systems with cables.
- TCP/IP — Connections using the TCP/IP protocol.

For modem connections, supply the following information:

**Modem type**

The type of modem you want to use. The supported devices are listed in the `/usr/lib/uucp/Devices` file. For more information, see `uucp_manual_setup(7)`.

**Baud rate or Any**

The speed at which the modem is to operate; for example: 1200, 2400, 9600, or any.



**Device name**

The name of the tty device that you want the modem to use, as listed in the /dev directory. If you are unsure of the terminal device, see ports(7).

**/etc/inittab entry ID**

The process ID for the ugetty process entry in the /etc/inittab file. The ugetty process sets up speed, terminal flags, and the line discipline for managing terminals. For more information, see ugetty(8).

---

**Note**

---

Run the ugetty command only on RS-232 lines, not printer or console lines.

---

For direct link connections, supply the following information:

**Remote system name or Direct**

The type of direct link. If you want to connect to a specific remote system, enter the name of the remote system. This restricts connections to that system only.

If you want to connect to any system to which you have a direct hardwired connection, check Direct.

**Baud rate or Any**

The speed at which the direct link is to operate; for example: 1200, 2400, 9600, or any.

**Device name**

The name of the tty device that you want the direct link to use, as listed in the /dev directory. If you are unsure of the terminal device, see ports(7).

**/etc/inittab entry ID**

The process ID for the ugetty process entry in the /etc/inittab file. The ugetty process sets up speed, terminal flags, and the line discipline for managing terminals. For more information, see ugetty(8).

---

**Note**

---

Use the `uugetty` command to configure only RS-232 lines, not printer or console lines.

---

For TCP/IP connections, supply the following information:

**Outgoing connections**

If you want to configure UUCP to place outgoing calls over TCP/IP, check Yes. When you enable UUCP to place outgoing calls over TCP/IP, an entry for TCP/IP is added to the `/usr/lib/uucp/Devices` file.

Otherwise, check No.

**Incoming connections**

If you want to configure UUCP to accept incoming calls over TCP/IP, check Yes. When you enable UUCP to accept incoming calls over TCP/IP, the `/etc/inetd.conf` file is modified. In addition, you must stop and restart the `inetd` daemon to be able to accept UUCP calls over TCP/IP.

Otherwise, check No.

**5.2.2.2 Information for Outgoing Systems**

Figure 5-4 shows the UUCP Outgoing Systems Worksheet. If you are viewing this manual online, you can use the print feature to print a copy of the worksheet. The sections that follow explain the information you need to record on the worksheet.

**Figure 5–4: UUCP Outgoing Systems Worksheet**

| UUCP Outgoing Systems Worksheet                |   |
|--|---|
| Remote system name:                            | _____   |
| Type of connection:                            | <input type="checkbox"/> Modem <input type="checkbox"/> Direct link <input type="checkbox"/> TCP/IP           |
| TCP/IP conversation protocol:                  | <input type="checkbox"/> g <input type="checkbox"/> t <input type="checkbox"/> e <input type="checkbox"/> f   |
| Calling times:                                 | _____   |
| Baud rate:                                     | _____ <input type="checkbox"/> Any  |
| Phone number (for modem):                      | _____   |
| Login ID:                                      | _____   |
| For modem/direct links,<br>expect-send string: | <input type="checkbox"/> Carriage returns<br><input type="checkbox"/> None<br><input type="checkbox"/> Prompt |

### Remote system name

The name of the remote system to which you plan to connect.

### Type of connection

The type of the connection. Check modem, direct hardwired, or TCP/IP. You must configure the type of the connection with the information from Section 5.2.2.1.

### TCP/IP conversation protocol

For TCP/IP connections, the TCP/IP conversation protocol, which can be one of the following:

- g — Specifies the default protocol, which provides error checking.
- t — Presumes an error-free channel and therefore is not reliable for use with modem connections.
- e — Used to communicate with sites that are running both Tru64 UNIX and other UNIX versions of UUCP.
- f — Relies on flow control of the data stream. It is meant for working over links that can be guaranteed to be virtually error free, specifically X.25/PAD links.

### Calling times

The times when your system is allowed to connect to the remote host. You can select the following times:

- Any time of any day

- Evenings — Monday to Friday 5 p.m. to 8 a.m.; Saturday and Sunday, all day
- Any three nights — You can choose the three nights from the following:
  - Monday to Friday, 11 p.m. to 8 a.m.
  - Saturday, all day
  - Sunday, until 5 p.m.
- Never

### **Baud rate or Any**

The baud rate that corresponds to a device you configured in the `/usr/lib/uucp/Devices` file, or you can specify any, if the device can be used at any speed.

### **Phone number (for modem)**

For modem connections, the telephone number of the remote system. You can enter the complete telephone number or a dialing prefix and the telephone number.

A dialing prefix is defined in the `/usr/lib/uucp/Dialcodes` file. The `/usr/lib/uucp/Dialcodes` file contains dial code abbreviations and partial phone numbers that complete the telephone entries in the `/usr/lib/uucp/Systems` file. Entries in the `/usr/lib/uucp/Dialcodes` file contain an alphabetic prefix attached to a partial phone number that can include, for example, access codes, area codes, and exchange numbers.

If you know the dialing prefix, enter it on the worksheet. If none is defined, enter it and the sequence of numbers to be associated with the prefix.

### **Login ID**

The login name for your system on the remote system. This must match the information in the `/etc/passwd` file on the remote system. Ask the administrator of the remote system for the login name and password that is assigned to your system on the remote system. The administrator of the remote system must include the login name and password for your system in the remote system's `/etc/passwd` file.

---

**Note**

---

Although the password for the login ID on the remote system is required in order to configure UUCP, to protect system security do not write the password on this worksheet.

---

### For modem/direct links, expect-send string

The *expect-send* string to be used immediately before performing the login on the remote system. You can choose one of the following:

- To send a series of carriage returns before expecting any characters from the remote system
- To specify no *expect-send* strings
- To be prompted to enter *expect-send* strings

Modems usually use a series of carriage returns as an *expect-send* string.

For more information on *expect-send* strings, see *Systems(4)*.

### 5.2.2.3 Information for Incoming Systems

Figure 5–5 shows the UUCP Incoming Systems Worksheet. If you are viewing this manual online, you can use the print feature to print a copy of the worksheet. The sections that follow explain the information you need to record on the worksheet.

**Figure 5–5: UUCP Incoming Systems Worksheet**

| UUCP Incoming Systems Worksheet      |  |
|--------------------------------------|--|
| Remote system name:                  | _____  |
| Local system name:                   | _____  |
| Login ID:                            | _____  |
| Alternative login ID:                | _____  |
| REQUEST option:                      | <input type="checkbox"/> Yes <input type="checkbox"/> No   |
| SENDFILES option:                    | <input type="checkbox"/> Yes <input type="checkbox"/> Call |
| Additional READ/WRITE locations:     | _____  |
| Additional NOREAD/NOWRITE locations: | _____  |
| Commands:                            | _____<br>_____<br>_____                                    |
| VALIDATE option:                     | <input type="checkbox"/> Yes <input type="checkbox"/> No   |
| CALLBACK option:                     | <input type="checkbox"/> Yes <input type="checkbox"/> No   |
| Phone number (for modem):            | _____  |

**Remote system name**

The name of the remote system you want to allow to establish incoming UUCP connections.

**Local system name**

The name of your system. The default provided is the name that you assigned to your system at installation.

**Login ID**

The login ID for the remote system. The login ID is automatically added to the `/etc/passwd` file on your system.

By convention, the login ID that you assign to a remote system establishing incoming connections is the system name prefixed with an uppercase u (U). For example, if you specify `machine1` for incoming connections, the login ID, by convention, is `Umachine1`; however, you can select any login ID.

You also have the option of adding a comment to the `/etc/passwd` file for this login ID.

**Alternative login ID**

You have the option to assign more than one login ID for each incoming system. Assigning multiple logins to a remote system allows you to maintain better access control for users on the remote system. With multiple logins, you can grant privileged users on the remote system more access on your system than you do to nonprivileged users. With multiple logins, you can assign multiple sets of permissions.

You must provide this information to the administrator of each remote system that will connect to your system as an incoming system.

**REQUEST option**

If you want a remote system to ask for any queued work on the local system that is meant for that remote system, check Yes; otherwise, check No.

If you check Yes, remote system users can transfer files to and execute commands on a local system more easily. If security is a consideration, you can restrict this access so that the local system retains control of file transfers and command executions initiated by remote systems.

### **SENDFILES option**

If you want the local system to try to send queued work to the calling remote system after the remote computer finishes transferring files to or executing commands on the local system, check Yes.

Security considerations at your site might require that you limit a remote system's access to the local system. In this case, check Call to send queued work to the remote system only when the local system contacts the remote system.

### **Additional READ/WRITE locations**

If you do not specify pathnames in the READ and WRITE options, uucp permits files to be transferred only to the `/usr/spool/uucppublic` directory. However, if you specify pathnames in these options, you must enter the pathname for every source and destination. If you enter a pathname in either option, you must also explicitly specify the public directory if you want the `uucico` daemon to be allowed to place files in that location.

### **Additional NOREAD/NOWRITE locations**

These options allow you to explicitly specify directories and files on the local system to which the remote system cannot transfer data. These are exceptions to the READ and WRITE options.

### **Commands**

A list of commands the remote system is allowed to run on the local system. If you list a set of commands, that list comprises the new default command set for the systems listed in the MACHINE entry of the `/usr/lib/uucp/Permissions` file. The default is the command `rmail` only.

### **VALIDATE option**

If you want the calling remote system to use a specific ID and password, check Yes; otherwise, check No.

If you use this option, no other ID from the remote system can call in. Several systems, however, can use the same ID. The VALIDATE option is meaningful only when the login ID and password are protected.

### **CALLBACK option**

If you want the local system to contact the remote system before the remote system can transfer any files to the local system, check Yes; otherwise, check No.

If both systems use the `CALLBACK` option in their respective `Permissions` files, they will never be able to communicate with each other.

### Phone number (for modem)

For modem connections, the phone number and speed of the modem attached to the local system. You must provide this information to the administrator of each remote system that will connect to your system as an incoming system.

## 5.3 Configuring UUCP

After you complete the required UUCP planning, use the `uucpsetup` script to configure UUCP. To invoke the `uucpsetup` script, enter the following command:

```
# /usr/sbin/uucpsetup
```

By default, the `uucpsetup` script prompts you for the information required to configure connections, incoming systems, and outgoing systems. To configure only specific components, you can specify one of the other options listed in Table 5–1.

**Table 5–1: Options for `uucpsetup` Command**

| Use this command:         | If you want to:   |
|---------------------------|---|
| <code>uucpsetup</code>    | Configure connections, incoming systems, and outgoing systems |
| <code>uucpsetup -i</code> | Configure the incoming systems only                           |
| <code>uucpsetup -o</code> | Configure the outgoing systems only                           |
| <code>uucpsetup -p</code> | Configure the <code>Poll</code> file                          |

The following sections provide information on how to configure connections, incoming systems, outgoing systems, and the `Poll` file.

### 5.3.1 Configuring Connections

After you invoke `uucpsetup`, use the the information you gathered in Section 5.2.2.1 to configure UUCP connections. The following guidelines explain how to answer some of the script questions:

- Device names — The script lists the available device names. Enter the last letter or number of the device that you want the modem to use. For example, if you want to use `tty01`, enter 1.



- `/etc/inittab` entry ID — The script prompts you for the *Identifier* field and asks if this entry will be used in shared mode. It automatically supplies information for the other fields. No two processes can have the same ID.

The following example illustrates how to select the process ID (PID) `u4`:

```
Select an ID for the process in /etc/inittab file
For example type 'u1': u4
```

The ID that you select is checked against those that exist in the `/etc/inittab` file. If the ID that you assign exists, the `uucpsetup` script prompts you to enter another ID.

You must also indicate whether the system will use the modem or direct line in shared mode.

For more information on the `/etc/inittab` file, see `inittab(4)`.

### 5.3.2 Configuring Outgoing Systems

After you invoke the `uucpsetup` script, use the the information you gathered in Section 5.2.2.2 to configure UUCP for outgoing systems. This enables you to use UUCP to connect to other remote systems.

If you are doing a complete UUCP setup, the `uucpsetup` script prompts you for information on outgoing systems when you finish configuring connections. The following guidelines explain how to answer some of the script questions:

- Phone number — If you choose a dialing prefix and the telephone number, the script prompts you to enter a prefix to be defined in the `/usr/lib/uucp/Dialcodes` file. After you enter the prefix, the script prompts you for the meaning of the prefix. Enter the sequence of numbers that you want the system to substitute for the prefix. The following example illustrates how to define the prefix `btown` to be the dialing sequence `1617772`:

```
Enter the prefix for the Dialcodes file; for example "boston"
stands for 9=16171234 : btown
What telephone number does the prefix stand for; Please include
the long distance access code, area, or country codes;
for example type 9=1617123 : 9=1617772
```

The `9` in this example is used to obtain a secondary dial tone. The `9` is site specific; it can be different for your site. The equal sign (=) is used with the `9`, or number for your site, and means “wait for the dial tone.” Following the equal sign (=) is the rest of the number.

- Password — For security considerations, the password is not written on the worksheet. However, when the script prompts for it, you must enter it.

If you define an outgoing TCP system, edit the `/etc/uucp/Systems` file and add an entry for the remote system. The remote system name must be the fully qualified name.

When you finish configuring your outgoing system, you need to configure the `/usr/lib/uucp/Poll` file. See Section 5.3.4 for more information.

### 5.3.3 Configuring Incoming Systems

After you invoke the `uucpsetup` script, use the the information you gathered in Section 5.2.2.3 to configure UUCP for incoming systems. This enables specific remote systems to connect to your system using UUCP.

If you are doing a complete UUCP setup, the script prompts you for information on incoming systems when you are done configuring outgoing systems.

The first time you add an incoming system, the Incoming Systems Configuration menu prompts you for the name of the system you want to add. After you add an incoming system, this menu offers you the following choices:

- Specify a remote system name.
- Specify options for all the other systems not specified in the `Permissions` file but listed in the `Systems` file.
- Neither. If you choose this option, the script terminates and the defaults for the options are not entered in the `Permissions` file.

The following guidelines explain how to answer some of the script questions:

- Password — The `uucpsetup` script invokes the `vipw` command, which starts your default editor (defined in the `EDITOR` environment variable) and allows you to edit the UUCP entry for the incoming system. After you are finished editing the `/etc/passwd` file, save the file, exit the editor, and supply a password for the new entry. The following example shows output from this process on a system that is configured to use the `vi` utility as its default editor:

```
Invoking 'vipw'.
Press RETURN to continue...
Return
root:fQPPWjF20Dfso:0:1:Charles Root:/:bin/csh
nobody:*Nologin:4294967294:4294967294:anonymous NFS user:/:
daemon:*:1:1:Mr Background,,,:/
uucp:No Login:2:2:UNIX-to-UNIX Copy:/usr/spool/uucppublic:\
    /usr/lib/uucp/uucico
bin:*:3:4:Mr Binary:/bin:
marcy:5jW0VXKeP6n1E:1242:15:Marcy Darcy,,,:\  
    /usr/users/marcy:/bin/false
Umachine1:H/kj951Fq12ub:2:2:uucp login:/usr/spool/uucppublic:\
```

```

    /usr/lib/uucp/uucico
~
~
~
"/etc/ptmp" 15 lines, 933 characters
:wq
15 password entries, maximum length 100

```

```

You must enter a password
Changing password for Umachine1.
New password:
Retype new password:

```

You must provide this information to the administrator of each remote system that will connect to your system as an incoming system.

- **Commands** — The script prompts you for each command separately.

If you define an incoming UUCP system and your system uses NIS, edit the `/etc/passwd` file and add the wildcard (`+:.`) as the last line (if it is not there already).

### 5.3.4 Configuring the Poll File

After you finish configuring an outgoing system, you need to configure the `/usr/lib/uucp/Poll` file to schedule the intervals at which the local system will poll remote systems. You can configure the `Poll` file by invoking the `uucpsetup` script with the `-p` option and completing the following steps:

1. Enter 1 (Configure the Poll file) from the Poll File Configuration Menu.
2. Enter the name of the remote system, which has been configured in the `/usr/lib/uucp/Systems` file as an outgoing system.
3. Enter the sequence of hourly intervals. For example, to have the system polled every 4 hours, enter 0 4 8 12 16 20.  
Press Return to update the `Poll` file.
4. To add another system to the `Poll` file, enter `y`; otherwise, press Return to exit `uucpsetup`.

See `Poll(4)` for more information about the `Poll` file.

### 5.3.5 Configuring the uucico Daemon

The `uucico` daemon transfers UUCP command, data, and execute files to remote systems. Both the local and remote systems run the `uucico` daemon, and the two daemons communicate with each other to complete transfer requests.

Typically, the `uucico` daemon is set up as the UUCP user's login shell for incoming connections, or it is automatically called by various UUCP commands for outgoing connections, and no further configuration is necessary. However, you might need to specify the type of flow control the `uucico` daemon uses for certain UUCP transfers. For example, if you establish a connection to a terminal server via a modem and then use the `telnet` utility to connect to a UUCP account, you might require a different type of flow control than a user who initiates UUCP transfers via a serial port connection.

To specify the type of flow control that the `uucico` daemon uses, set the `FLWCTL` environment variable for the accounts on your system that use UUCP connections. Permitted values for `FLWCTL` are: `HW` (hardware), `SW` (software), `HSW` (hardware and software), and `NONE`. The local and remote systems must use the same type of flow control. If the remote site runs UUCP on a different platform, set `FLWCTL` to `NONE` on the Tru64 UNIX system.

For example, to establish a UUCP connection in a `telnet` session, you would set flow control to `NONE` as follows:

```
$ export FLWCTL=NONE
$ /usr/lib/uucp/uucico remote_site
```

On a system that is configured to allow other sites to dial in, you can use the following procedure to create a customized script that automatically sets the `FLWCTL` variable:

1. Create a file, optionally called `uu_start`, that contains the following commands:

```
#!/bin/ksh
export FLWCTL=NONE
exec /usr/lib/uucp/uucico $*
```

2. Change the permissions on the file to make it executable:

```
# chmod +x /usr/local/bin/uu_start
```

3. Change the UUCP account's login shell from `/usr/lib/uucp/uucico` to the new executable file:

```
# chsh uucp
Old shell: /usr/lib/uucp/uucico
New shell: /usr/local/bin/uu_start
```

## 5.4 Managing UUCP

This section describes how to perform the following UUCP tasks:

- Monitor the file transfer queue

- Clean up the spooling directories
- View the log files
- Clean up the `su` log and `cron/log` files
- Limit the number of remote executions
- Schedule work in the spooling directory
- Call file transfer programs
- Poll remote systems

## 5.4.1 Monitoring the File Transfer Queue

Monitoring the file transfer queue enables you to determine the status of several types of networking operations, including jobs that have been queued on a local system for transfer to a remote system. General users and system administrators can monitor the file transfer queue.

### 5.4.1.1 Getting Queue Status Manually

To get queue status manually, use the `uustat -q` command.

This command lists the jobs queued for all systems. The jobs listed in the queue include jobs that are currently executing as well as jobs that are waiting to execute. If a status file exists for a system, its date, time, and status information are reported.

The `uustat` command also allows you to do the following:

- Get information about the status of mail activities
- Control `uucp` jobs queued to run on remote systems
- Check the status of `uucp` connections to other systems, using the `-m` option
- Cancel transfer requests, using the `-k` option
- Monitor requests for file transfers generated with the `uucp` and `uuto` commands, and requests for command executions generated with the `uux` command

See `uustat(1)` for more information on `uustat` options.

The following example shows all jobs in the current queue: one command file for system `host4`, three command files for system `host6`, and two command files for system `host8`. The command files for system `host6` have been in the queue for 2 days.

```
# uustat -q
host4 1C Sat May 9 11:12:30 1992 SUCCESSFUL
host6 3C(2) Sat May 9 11:02:35 1992 CAN'T ACCESS DEVICE
```

```
host8 2C Sat May 9 10:54:02 1992 NO DEVICES AVAILABLE
```

### 5.4.1.2 Getting Queue Status Automatically

You can automatically receive status information about the uucp file transfer queue. To enable this mechanism, edit the `/usr/spool/cron/crontabs/uucp` file and delete the comment character (`#`) from the beginning of the following line:

```
# 48 8,12,16 * * * /usr/lib/uucp/uudemon.admin > /dev/null
```

In the preceding example:

|         |  |
|---------|--|
| 48      | Represents minutes   |
| 8,12,16 | Represents hours based on 24-hour clock notation   |
| * * *   | Three asterisks are placeholders representing the day of the month, the month of the year, and the day of the week |

The cron daemon will run the `uudemon.admin` shell script daily at 48 minutes past the hours 8, 12, and 16; that is, at 8:48 a.m., 12:48 p.m., and 4:48 p.m. The `uudemon.admin` script sends mail to the uucp login ID containing queue status information.

---

#### Note

---

These times are the defaults. You can change the time to fit the needs of your site by editing the line in the `/usr/spool/cron/crontabs/uucp` file.

---

You can also manually run the `uudemon.admin` script by entering the following command:

```
# /usr/lib/uucp/uudemon.admin
```

### 5.4.1.3 Guidelines for Checking Queue Status

When examining queue status, check the number and age of the file-transfer and command execution requests queued in the `/usr/spool/uucp/system_name` directory. In some cases, queued jobs remain in the queue for some time, essentially going undelivered. The status information you need to check includes:

- The age in days of the oldest request in each queue
- The number of times the local system has tried and failed to reach the specified computer
- The reason for the failure to contact the specified system

See Appendix D for error messages and solutions.

If necessary, delete the files in the queue, either manually or automatically. See Section 5.4.2 for information on deleting files.

## 5.4.2 Cleaning Up the Spooling Directories

Each system connected by UUCP has the following spooling directories:

- The `/usr/spool/uucp/system_name` directory is the UUCP spooling directory. It contains queued local requests for file transfers and command executions on remote systems. These files are removed by the `uucp` program after they are transferred to the designated system.
- The `/usr/spool/uucppublic` directory is the UUCP public directory. When a user transfers a file to a remote system or issues a request to execute a command on an other system, the files generated by these UUCP commands are stored in the public directory on the designated system.

Depending upon the size of your installation and the number of files sent to the local `/usr/spool/uucppublic` directory by users on remote systems, the public directory can become quite large. Similarly, if requests are not transferred to remote systems for whatever reasons, the spooling directory could also become quite large. Therefore, part of UUCP management is to clean up the spooling directories and conserve disk resources.

### 5.4.2.1 Cleaning Up Directories Manually

To clean up the spooling directories manually, log in as root and remove the files by using the `uucleanup` command.

The `uucleanup` program performs the following tasks:

- Informs the system manager of requests to send files to and receive files from remote systems that the local system cannot contact.
- Warns users about requests that have been waiting in the spooling directory for a given period of time. The default is 1 day.
- Returns to the original sender mail that cannot be delivered.
- Removes all other files older than a specified number of days from the spooling directory.

---

#### Note

---

Depending on the size of your installation and the available storage space on the local system, you can set the age limit for any length of time. However, it is best to allow files to

remain in the spooling directory for at least the default number of days.

---

See `uucleanup(8)` for more information on the `uucleanup` command options.

The following example deletes all old files in the UUCP spooling and public directories for system `host2` on the local system:

```
# uucleanup -shost2
```

#### 5.4.2.2 Cleaning Up Directories Automatically

Although automatic cleanup is not enabled when UUCP is installed, you can enable it by doing the following:

1. Log in as root.
2. Edit the `/usr/spool/cron/crontabs/uucp` file and delete the comment character (`#`) from the beginning of the following line:

```
# 45 23 * * * ulimit 5000; /usr/lib/uucp/uudemon.cleantu > /dev/null
```

In the preceding example:

|       |  |
|-------|--|
| 45    | Represents minutes   |
| 23    | Represents hours based on 24-hour clock notation   |
| * * * | Three asterisks are placeholders representing the day of the month, the month of the year, and the day of the week |

The cron daemon will start the `uudemon.cleantu` shell script daily at 45 minutes after hour 23; that is, at 11:45 p.m. The shell script in turn starts the `uucleanup` program. This time is the default. You can change the time to fit the needs of your site by editing the line in the `/usr/spool/cron/crontabs/uucp` file.

You can instruct the cron daemon to run the `uudemon.cleantu` shell script daily, weekly, or at longer intervals, depending on the number of `uucico` and `uuxqt` transactions that occur on the local system.

The `uudemon.cleantu` script incorporates the actions of the `uucleanup` program and performs the following additional tasks:

- Locates and deletes empty directories and files older than 30 days from the `/usr/spool/uucppublic` directory. This helps keep the local file system from overflowing when users send files to the public directory. If the local system does not have enough storage space to accommodate a large `/usr/spool/uucppublic` directory, you can change the 30-day default to a shorter time period by modifying the `uudemon.cleantu` shell script.



- Cleans up all the `uucp` spooling directories, including the public directories, unless you direct it to clean up only the directories of a specific system by issuing the `uucleanup -s system_name` command.
- Updates archived log files, removing log information more than 2 days old. The script removes log files for individual computers from the `/usr/spool/uucp/.Log` directory, merges them, and places them in the `/usr/spool/uucp/.Old` directory, which contains old log information.
- Mails a summary of the status information gathered during the current day to the UUCP login ID. You can modify the script to send status information to other login IDs, such as `root`.

The operating system allots UUCP a specified amount of storage space for any one log file; the number of blocks is determined by the default `ulimit` value. If the `uudemon.cleanu` script fails to execute because the `ulimit` value is set too low for the requirements of the local system, increase the default `ulimit` value.

See `uudemon(8)` for more information on command options.

### 5.4.2.3 Guidelines for Removing Files

When removing files from the queue, observe the guidelines for the following files:

- Execute files — Usually, you can remove execute files that have been in the queue for at least 2 days, using either the `uucleanup` or `uudemon.cleanu` script. The execute files are still queued because the data files required to execute the specified command on the designated system were not transferred. Since data files are generally sent at the same time as execute files, the transfer probably failed at the point of destination. Execute files are named `X.filename` and data files are named `D.filename`.
- Command files — Before removing old command files, make every possible effort to establish the connection and transfer the files. You can then remove these files by using either the `uucleanup` or `uudemon.cleanu` script. Command files are named `C.filename`.

### 5.4.3 Viewing Log Files

The `uucp` program creates a log file for each remote system with which your local system communicates. Each time you use the networking utilities facility, `uucp` places status information about each transaction in the appropriate log file. Log file names can be in either of the following forms:

```
/usr/spool/uucp/.Log/daemon_name/system_name
```

```
/usr/spool/uucp/.Log/command_name/system_name
```

In the preceding example:

|                     |   |
|---------------------|---|
| <i>daemon_name</i>  | Represents either <code>uucico</code> (called by the <code>uucp</code> and <code>uuto</code> commands) or <code>uuxqt</code> (called by the <code>uux</code> command) |
| <i>command_name</i> | Represents either <code>uucp</code> or <code>uux</code>   |
| <i>system_name</i>  | Represents the name of the system with which your local system is communicating   |

To display individual log files, use the `uulog` command.

You can use the `uulog` command to display a summary of `uucp` and `uux` requests by user or by system. See `uulog(1)` for more information on the `uulog` command and its options.

Instead of viewing the log files individually, you can have the `uudemon.cleanu` script automatically append these log files to one primary log file, and then view only the primary log file.

The `uudemon.cleanu` script combines the `uucico`, `uuxqt`, `uux`, and `uucp` log files on a system and stores them in a directory named `/usr/spool/uucp/.Old`. By default, the `uudemon.cleanu` script saves log files that are up to two days old.

You can change the default by modifying the `-o2` option in the following line in the `uudemon.cleanu` script:

```
uucleanup -D7 -C7 -X2 -o2 -W1
```

If storage space is a problem on a particular system, consider reducing the number of days that the files are kept in the individual log files. See Section 5.4.2.2 for information on setting up the `uudemon.cleanu` script.

The following command displays the log file for `uucico` requests for system `host2`:

```
# uulog -s host2
```

The following command displays the log file for `uuxqt` requests for system `host1`:

```
# uulog -x host1
```

The following command displays the last 40 lines of the file transfer log for system `host6` and executes a `tail -f` command. Press `Ctrl/c` to terminate the command.

```
# uulog -f host6 -40
```

#### 5.4.4 Cleaning Up `sulog` and `cron/log` Files

The following two system log files are affected by the `uucp` program:

- The `/usr/adm/sulog` file contains a history of superuser (`su`) command usage. The `uudemon` entries in the `/usr/spool/cron/crontabs/uucp` file each use the `su` command.
- The `/usr/adm/cron/log` file contains a history of all the processes generated by the `cron` daemon.

Both files can grow quite large over a period of time. Purge these files periodically to keep them at a reasonable size. See *System Administration* for information on these files.

### 5.4.5 Limiting the Number of Remote Executions

The `Maxuuxqts` file, located in the `/usr/lib/uucp` directory, limits the number of `uuxqt` processes running simultaneously on a local system. Typically, the file requires no configuration or maintenance unless the system on which it is installed is utilized frequently and heavily by users on remote systems.

To change the number of `uuxqt` processes on the system, edit the `Maxuuxqts` file and change the ASCII number to meet the needs of your installation; the default is 2. In general, the larger the number, the greater the potential load on the local system.

### 5.4.6 Scheduling Work in the Spooling Directory

When users issue `uucp` commands to copy files and execute remote commands, the files containing these work requests are queued for transfer in the local `/usr/spool/uucp/system_name` directory. The UUCP `uusched` daemon schedules the transfer of these files.

#### 5.4.6.1 Starting `uusched` Manually

You can start the `uusched` daemon manually to schedule jobs by executing the `uusched` command. See `uusched(8)` for a list of available options.

#### 5.4.6.2 Starting `uusched` Automatically

Although you can start the `uusched` daemon manually, the preferred method is to start it automatically at specified intervals by using the `uudemon.hour` shell script, which is stored in the `/usr/lib/uucp` directory. The shell script, in turn, is started periodically by the `cron` daemon, based on instructions in the `/usr/spool/cron/crontabs/uucp` file.

The `/usr/lib/uucp/Maxuuscheds` file limits the number of remote systems that the `uucico` daemon can contact at any one time. This file is used in conjunction with the `uusched` daemon and the lock files in the

`/usr/spool/locks` directory to determine the number of systems currently being polled.

The `Maxuuscheds` file requires no configuration or maintenance unless the system on which it is installed is utilized frequently and heavily by users on remote systems. You use this file to help manage system resources and load averages.

The `Maxuuscheds` file contains a number that you can change to meet the needs of your installation; the default is 2. In general, the larger the number, the greater the potential load on the local system.

See `uusched(8)` for more information on the `uusched` command and its options.

The following command starts the `uusched` daemon manually as a background process:

```
# /usr/lib/uucp/uusched &
```

### 5.4.7 Calling File Transfer Programs (`uudemon.hour`)

The `uudemon.hour` shell script is used in conjunction with the `Poll` file, the `uudemon.poll` shell script, and the `/usr/spool/cron/crontabs/uucp` file to initiate calls to remote systems. Specifically, `uudemon.hour` calls programs involved in transferring files between systems at specified hourly intervals.

You can instruct the `cron` daemon to run the `uudemon.hour` shell script at specified hourly intervals. The frequency at which you run the script depends on the amount of file transfer activity originating from the local computer.

Although the `uudemon.hour` shell script is not enabled when UUCP is installed, you can enable it by doing the following:

1. Log in as root.
2. Edit the `/usr/spool/cron/crontabs/uucp` file and delete the comment character (`#`) from the beginning of the following line:

```
# 25,55 * * * * /usr/lib/uucp/uudemon.hour > /dev/null
```

In the preceding example:

|                      |  |
|----------------------|--|
| <code>25,55</code>   | Represents minutes past the hour   |
| <code>* * * *</code> | Four asterisks are placeholders representing the hour interval, the day of the month, the month of the year, and the day of the week |

The `cron` daemon will run the `uudemon.hour` script at 25 minutes past the hour and again at 55 minutes past the hour; for example, at 8:25 a.m. and 8:55 a.m., 9:25 a.m. and 9:55 a.m., and so on.

These times are the defaults. You can change the time to fit the needs of your site by editing the line in the `/usr/spool/cron/crontabs/uucp` file.

If users on the local system initiate a large number of file transfers, you might need to specify that the `cron` daemon run the `uudemon.hour` script several times an hour. If the number of file transfers originating from the local system is low, you can probably specify a start time once every 4 hours, for example.

#### 5.4.8 Polling Remote Systems (`uudemon.poll`)

The `uudemon.poll` shell script is used in conjunction with the `Poll` file, the `uudemon.hour` shell script, and the `/usr/spool/cron/crontabs/uucp` file to initiate calls to remote systems. The `uudemon.poll` shell script polls the systems listed in the `/usr/lib/uucp/Poll` file. In addition, it creates command files for the systems listed in the `Poll` file.

The time at which you run the `uudemon.poll` script depends on the time at which you run the `uudemon.hour` script. You generally schedule the polling shell script to run before the hourly script. This schedule enables the `uudemon.poll` script to create any required command files before the `cron` daemon runs the `uudemon.hour` script.

Although the `uudemon.poll` script is not enabled when UUCP is installed, you can enable it by doing the following:

1. Log in as root.
2. Edit the `/usr/spool/cron/crontabs/uucp` file and delete the comment character (`#`) from the beginning of the following line:

```
# 20,50 * * * * /usr/lib/uucp/uudemon.poll > /dev/null
```

In the preceding example:

|                      |  |
|----------------------|--|
| <code>20,50</code>   | Represents minutes past the hour   |
| <code>* * * *</code> | Four asterisks are placeholders representing the hour interval, the day of the month, the month of the year, and the day of the week |

The `cron` daemon will run the `uudemon.poll` script at 20 minutes past the hour and again at 50 minutes past the hour, for example, at 8:20 a.m. and 8:50 a.m., 9:20 a.m. and 9:50 a.m., and so on.

These times are the defaults. You can change the times at which the `cron` daemon executes the `uudemon.poll` script to correspond to the

times you set up for the `uudemon.hour` script. Set the cron daemon to run the `uudemon.poll` script approximately 5 to 10 minutes before running the `uudemon.hour` script.

# 6

---

## Network Time Protocol

The Network Time Protocol (NTP) provides accurate, dependable, and synchronized time for hosts on both wide area networks (WANs) like the Internet network and local area networks (LANs). In particular, NTP provides synchronization traceable to clocks of high absolute accuracy, and avoids synchronization to clocks keeping bad time. The Tru64 UNIX NTP subsystem is derived from the University of Delaware's implementation, NTP Version 4.98a.

This chapter describes:

- The Tru64 UNIX NTP subsystem and its components (Section 6.1)
- How to plan for your NTP configuration (Section 6.2)
- How to configure your system to use NTP (Section 6.3)
- How to enable the high-resolution clock (Section 6.4)
- How to monitor hosts that are running NTP (Section 6.5)
- How to query servers that are running NTP (Section 6.6)

For introductory information on NTP, see `ntp_intro(7)`. For troubleshooting information, see Section 9.10. Also, for information about the latest releases of NTP, more examples of how to configure NTP subnets, and more extensive NTP troubleshooting information, visit the NTP website at <http://www.eecis.udel.edu/~ntp>.

As an alternative to NTP, you can set your system time by using the `rdate` command or the `timed` daemon.

---

### Note

---

The `timed` daemon is provided only for compatibility; use NTP for time synchronization. If you plan to run both the `timed` daemon and NTP, configure NTP first and run the `timed` daemon with the `-E` option.

---

For more information on the `rdate` command, see `rdate(8)` and `ntp_manual_setup(7)`.

For more information on the `timed` daemon, see `timed(8)` and `timedsetup(8)`.

## 6.1 NTP Environment

In the NTP environment, systems can have the following roles:

- Client — An NTP client system is a system that synchronizes its time with local NTP servers.
- Server — An NTP server is a local system that synchronizes its time with an Internet NTP server or with a local reference clock, or both for better accuracy.

Figure 6–1 shows a sample NTP configuration on a LAN in which host D is an NTP server that uses a local reference clock as its time source. Hosts A, B, C, E, F, and G are NTP clients, synchronizing their time with host D.

**Figure 6–1: Sample NTP Configuration (Local Clock)**

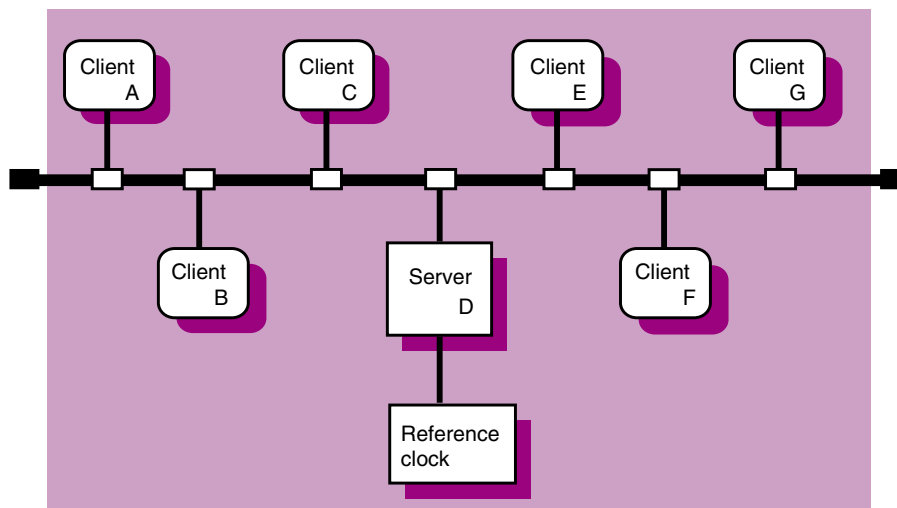

ZK-1158U-AI

Figure 6–2 shows a sample NTP configuration in which host D is an NTP server that uses an Internet time server as its time source. Hosts A, B, C, E, F, and G are NTP clients, synchronizing their time with host D.



**Figure 6–2: Sample NTP Configuration (Internet Source)**

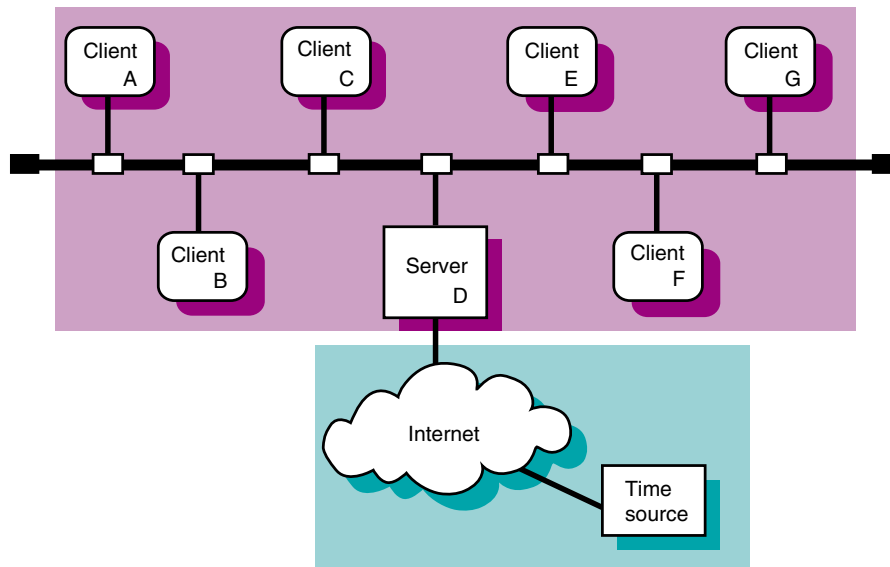

ZK-1159U-AI

## 6.2 Planning NTP

Your system can be a local NTP server or an NTP client, or both. Figure 6–3 shows the NTP Setup Worksheet, which you can use to record the information required to configure NTP. If you are viewing this manual online, you can use the print feature to print a copy of this worksheet. The following sections explain the information you need to record on the worksheet.

Figure 6–3: NTP Setup Worksheet

| NTP Setup Worksheet       |              |          |          |  |
|---------------------------|--------------|----------|----------|--|
| <b>Server</b>             |              |          |          |  |
| Time source: _____        |              |          |          |  |
| Server Internet address:  | Server name: | Version: | Stratum: |  |
| _____                     | _____        | _____    | _____    |  |
| _____                     | _____        | _____    | _____    |  |
| _____                     | _____        | _____    | _____    |  |
| <b>Client</b>             |              |          |          |  |
| Local NTP server address: | Server name: | Version: |          |  |
| _____                     | _____        | _____    |          |  |
| _____                     | _____        | _____    |          |  |
| _____                     | _____        | _____    |          |  |

### 6.2.1 Server Information

#### Time source

Your system's time source. For local NTP servers, the time source is one of the following:

- Internet NTP servers — If your system is connected to the Internet, you can obtain a list of possible NTP Internet servers from **<http://www.eecis.udel.edu/~ntp>** on the World Wide Web. Select a minimum of three systems from the server list with which to synchronize the time on your local NTP servers. Obtain permission from the contact person listed for each Internet server before specifying it as a server for your local NTP servers.
- A reference clock — If your network is not connected to the Internet network, you can select a system on your network to configure with a reference clock, which obtains its time via radio broadcasts or satellite transmissions. As a last resort, if no Internet servers or reference clock devices are available, you can select a system on your network to configure with a local reference clock, which means that the system uses its own CPU timekeeping unit as a reference clock.

See `ntp_manual_setup(7)` and `ntp.conf(4)` for information about configuring different types of reference clocks.

**Server Internet address**

The IP address of the Internet NTP server or the local reference clock. Local NTP servers are the time sources for NTP clients.

**Server name**

The host name of the Internet NTP server.

**Version**

The version of NTP daemon running on the Internet NTP server or the local reference clock. This can be Version 1 (the `ntpd` daemon), Version 2 (the `xntpd` daemon), or Version 3 (the `xntpd` daemon). Servers running Version 3.2 or earlier of the Tru64 UNIX operating system run Version 2 (the `xntpd` daemon); servers running Version 4.0 of the Tru64 UNIX operating system run Version 3 (the `xntpd` daemon).

**Stratum**

A stratum value describes the accuracy of a system's reference clock: the higher the number, the less accurate the clock.

If you are configuring a local reference clock, you can specify a higher stratum value to indicate that the clock's time is not very accurate. This discourages other systems from using your clock as a reliable time source, because NTP clients will obtain the time from the server with the lowest stratum they can find. For example, if you set a stratum of 8 for your local reference clock, NTP clients will ignore your server and use a server with stratum 2 or lower (if one can be found).

You can supply a value from 0 to 15 for the Stratum field; however it is best not to override the default value assigned by NTP unless you have a specific reason for doing so. For local reference clocks, that default value is 3. For other clocks, the default value is 0.

## 6.2.2 Client Information

**Local NTP server address**

The local NTP server IP address. Local NTP servers are the time sources for NTP clients.

**Server name**

The local NTP server name.

**Version**

The version of NTP daemon running on the local NTP server. This can be Version 1 (the `ntpd` daemon), Version 2 (the `xntpd` daemon),

or Version 3 the (the `xntpd` daemon). Servers running Version 3.2 or earlier of the Tru64 UNIX operating system run Version 2 (the `xntpd` daemon); servers running Version 4.0 of the Tru64 UNIX operating system run Version 3 (the `xntpd` daemon).

## 6.3 Configuring NTP

Use the SysMan Menu application of the Common Desktop Environment (CDE) Application Manager to configure NTP servers and clients. To invoke the SysMan Menu application, follow the instructions in Section 1.2.1.

---

### Note

---

Do not use the SysMan Menu to configure NTP on local NTP servers that use a local or external reference clock as a time source. Instead, see `ntp_manual_setup(7)` for instructions.

Also, if you plan to use both NTP and the `timed` daemon, set up NTP prior to setting up the `timed` daemon.

---

To configure NTP, do the following:

1. From the SysMan Menu, select **Networking**→**Additional Network Services**→**Network Time Protocol (NTP)**→**Configure system as an NTP client** to display the **Configure NTP Client** dialog box.

Alternatively, enter the following command on a command line:

```
# /usr/bin/sysman ntp_config
```

2. Indicate whether you want to enable authentication by selecting the appropriate check box. If you choose to enable authentication, you must enter at least one authentication key as follows; repeat the steps to add additional keys:
  - a. Select **Add** under the **Authentication Keys** list to display the **Add/Modify** dialog box.
  - b. Enter the **Key Number** and **Key** for a peer or peers. The **Key Number** is a number from 1–15 that identifies the **Key**. The **Key** is an alphanumeric password of 1–8 characters with no spaces.
  - c. Select **OK** to add the authentication key to the list and to dismiss the **Add/Modify** dialog box.

Your authentication keys are stored in the `/etc/ntp.keys` file when you save your configuration and close the **Configure NTP Client** dialog box.

3. Select Add under the Servers & Peers list to display the Add/Modify dialog box.
4. Enter the host name, mode, version, and key number for an NTP server. If the NTP Server's IP address is not available through DNS or NIS, you must add it to the `/etc/hosts` database on your system as described in *Network Administration: Connections*.

For clients, enter the information for an NTP server that is local to your site.

For servers, enter the information for an Internet NTP server or a local reference clock. (See Section 6.2 for information.) If you are configuring a local reference clock and you need to override the default stratum that the `xntpd` daemon assigns to it, select the Fudge Factor check box and select a value from 0 to 15 for the Stratum field.

The information will be recorded in the `/etc/ntp.conf` file. For clients, entries in this file are designated as server entries because clients can synchronize their time only with these systems. An NTP server, however, can contain server and peer entries in its `ntp.conf` file. A peer system can be synchronized to another system's time or it can synchronize another system's time to its own.

5. Select OK to validate the parameters you entered and to dismiss the Add/Modify dialog box. To add other NTP servers, repeat steps 3 through 5. It is best to specify at least three servers.
6. Indicate whether you want to correct large time differences by selecting the appropriate check box.

This option, enabled by default, allows `xntpd` to correct differences of more than 1000 seconds between your system time and your system's NTP server's time that occur after the `xntpd` daemon is started. The `ntpdate` command is run at boot time by the `/sbin/init.d/settime` script to correct initial time differences. If your system is sensitive to security threats, do not enable this option. If you do not use this option, time differences of more than 1000 seconds will cause the `xntpd` daemon to log a message to the `syslogd` daemon and exit.

7. Indicate whether you want to prevent time from being set backwards by selecting the appropriate check box. The default is to allow the `xntpd` daemon to set the system time backward.
8. Select OK to accept the configuration and to close the Configure NTP Client dialog box.
9. A new dialog box is displayed indicating that the changes have been saved and prompting you to start the `xntpd` daemon.

10. Select Yes to start the daemon and apply your changes immediately, or select No to close the Configure NTP Client dialog box and apply the changes the next time you reboot your system.

---

**Note**

---

When you start NTP, the system attempts to synchronize its clock with an NTP server's clock. If you previously enabled a screen saver on your system, the time difference might be enough to activate it. In some cases, this blanks the screen, but it does not harm the system. Move the mouse or hit a key on the keyboard to reactivate the display.

---

If you choose Yes, you are informed that the NTP daemons have been started. Select OK to dismiss the message and to close the Configure NTP Client dialog box.

You can modify your NTP configuration after the initial setup. You can also stop and restart the `xntpd` daemon as necessary. See the online help for more information.

## 6.4 Enabling the High-Resolution Clock

The operating system includes an optional high-resolution clock that can be used for time-stamping and for measuring events that occur on the order of microseconds, such as the time spent in a critical code path. Programmers might be able to use this information to find the source of a bug or to determine where a program can be optimized to improve performance.

To enable the high-resolution clock, add the following line to the kernel configuration file and rebuild the kernel:

```
options MICRO_TIME
```

The system clock (`CLOCK_REALTIME`) resolution as returned by the `clock_getres` function does not change, nor does the timer resolution. However, the time as returned by the `clock_gettime` routine is extrapolated between the clock ticks, and the granularity of the time returned is in microseconds. The resulting time values are SMP-safe, they are monotonically increasing, and they have an apparent resolution of 1 microsecond.

## 6.5 Monitoring Hosts Running the `xntpd` Daemon

You can monitor the hosts running the `xntpd` daemon by using either the `ntpq` command or the `xntpdc` command.

To monitor the local host's NTP status using the `ntpq` command, use the following syntax:

```
ntpq [options...]
```

To monitor remote hosts' NTP status using the `ntpq` command, use the following syntax:

```
ntpq [options...] host1 host2...
```

Table 6–1 shows the `ntpq` command options.

**Table 6–1: Options to the `ntpq` Command**

| Option                     | Function  |
|----------------------------|---|
| <code>-c subcommand</code> | Interprets <i>subcommand</i> as an interactive format command and adds it to a list of commands to be executed on the specified host or hosts |
| <code>-i</code>            | Forces <code>ntpq</code> to operate in interactive mode   |
| <code>-p</code>            | Prints a list of peers and a summary of their state   |

You can specify `ntpq` subcommands on the command line with the `-c` option, or you can run the `ntpq` program interactively with the `-i` option. When you are finished entering subcommands in interactive mode, enter `quit` to exit the program.

By default, the subcommands apply to the local host. You can specify a host other than the local host on the command line or with the `host` subcommand in interactive mode. See `ntpq(8)` for more information about this command and its subcommands.

The following example shows normal output from the `ntpq` command with the `-p` option (or `peers` subcommand):

```
% ntpq -p
      remote           refid      st when poll reach  delay  offset  disp
-----
*host2.corp.com host121.corp.co  2   47  64  377   31.3   93.94   16.5
+host4.corp.com host2.corp.com   3  212 1024 377   33.8   89.58   16.9
 host8.corp.com host2.corp.com  16 never  64    0    0.0    0.00  64000
```

The last line of the previous example shows that `host8` is either not running NTP or cannot be reached.

To monitor the local host's NTP status using the `xntpd` command, use the following syntax:

```
xntpd [options...]
```

To monitor remote hosts' NTP status using the `xntpd` command, use the following syntax:

**xntpdc** [*options...*] *host1 host2...*

---

**Note**

---

The latest versions of the `xntpdc` command and `xntpd` daemon, delivered with NTP Version 4, are incompatible with previous versions of NTP. If you use the latest `xntpdc` command to collect information from an older `xntpd` daemon, or an older `xntpdc` command to collect information from the latest `xntpd` daemon, you will receive inconsistent results.

---

Table 6–2 shows some of the `xntpdc` command options.

**Table 6–2: Options to the `xntpdc` Command**

| Option                     | Function   |
|----------------------------|--|
| <code>-c subcommand</code> | Interprets <i>subcommand</i> as an interactive format command and adds it to a list of commands to be executed on the specified host or hosts. |
| <code>-i</code>            | Forces <code>xntpdc</code> to operate in interactive mode.   |
| <code>-l</code>            | Prints a list of peers that are known to the server.   |
| <code>-p</code>            | Prints a list of peers and a summary of their state. This is similar in format to the <code>ntpq -p</code> command.                            |

See `xntpdc(8)` for more information on this command and its subcommands.

The following example shows normal output from the `xntpdc` command with the `-p` option:

```
% xntpdc -p
      remote           refid      st  when poll reach  delay  offset  disp
=====
*host2.corp.com host121.corp.co  2    47   64   377   31.3   93.94   16.5
+host4.corp.com host2.corp.com   3   212 1024   377   33.8   89.58   16.9
.host5.corp.com host12.usc.edu    2   111 1024   377   39.1   46.98   17.7
```

## 6.6 Querying Servers Running NTP

You can query time by using the `ntp` and `ntpdate` commands. However, it is best to use the `ntpdate` command because it works with all versions of NTP and provides additional features.



# 7

---

## Mail System

The Tru64 UNIX mail system enables users to send mail to other users, whether on the same system, same network, or the other side of the world. This chapter describes:

- The Tru64 UNIX mail system and its components (Section 7.1)
- How to plan for your mail configuration (Section 7.2)
- How to configure mail (the `sendmail` utility) on a standalone system or across an enterprise (Section 7.3)
- How to configure Post Office Protocol (POP) mail (Section 7.4)
- How to configure Internet Message Access Protocol (IMAP) mail (Section 7.5)
- How to administer mail on server and client systems (Section 7.6)
- Utilities you can use to process and receive mail (Section 7.7)

For additional introductory information on mail, see `mail_intro(7)`, the *sendmail* book by O'Reilly & Associates, and the *Sendmail Installation and Operation Guide* (provided in PDF format on the Tru64 UNIX Documentation CD-ROM). For troubleshooting information, see Section 9.11 for the `sendmail` utility and Section 9.12 for POP and IMAP mail.

The mail daemons in Tru64 UNIX are based on `sendmail` Version 8.9.3 from Sendmail, Inc, POP3 Version 2.5.3 from Qualcomm, Inc., and Cyrus IMAP4 Version 1.6.19 from Carnegie-Mellon University. If you need later versions of these packages than the operating system offers, you can obtain updated software directly from the aforementioned organizations or you can obtain the Internet Express for Tru64 UNIX product (formerly Open Source Internet Solutions), a collection of popular Open Source software that Compaq distributes on a CD-ROM.

The Internet Express kit usually contains more up-to-date versions of the Open Source software than the operating system because the kit is updated and distributed several times a year. Internet Express also contains an administration utility that allows you to easily configure advanced features of `sendmail`, including masquerading, virtual domains, anti-spam, and the Lightweight Directory Access Protocol (LDAP). For more information about the Internet Express product, see the following URL:

[http://tru64unix.compaq.com/internet/prod\\_sol.htm](http://tru64unix.compaq.com/internet/prod_sol.htm)

## 7.1 Mail Environment

In the mail environment, systems can have the following roles:

- **Standalone** — A mail standalone system is one that processes, sends, and delivers mail locally. This is useful for configurations of from 1 to 6 systems. In small LAN configurations of two or more systems, one system serves the mailbox to the other systems using NFS. In this case, NFS must be configured on all systems.
- **Client** — A mail client system is a system that sends all of its mail to a mail server for processing and delivery. If the addressee is on the client system, the mail is delivered there. If not, the mail is forwarded to the destination system.
- **Server** — A mail server system is a system that receives mail from clients in a local domain for processing and delivery to other domains, the Internet, or other networks. In addition, the server also receives mail from other domains for delivery.

Figure 7-1 shows a sample standalone configuration on a LAN in which all hosts are configured as mail standalone systems. Host B is also an NFS server, exporting the `/var/spool/mail` directory to hosts A, C, D, and E. Hosts A, C, D, and E are also NFS clients, importing the `/var/spool/mail` directory from host B.

The hosts must also have identical information in their `passwd` and `aliases` files. This information can be distributed either by using NIS or by manually editing the files on each system.

**Figure 7–1: Sample Mail Standalone Configuration**

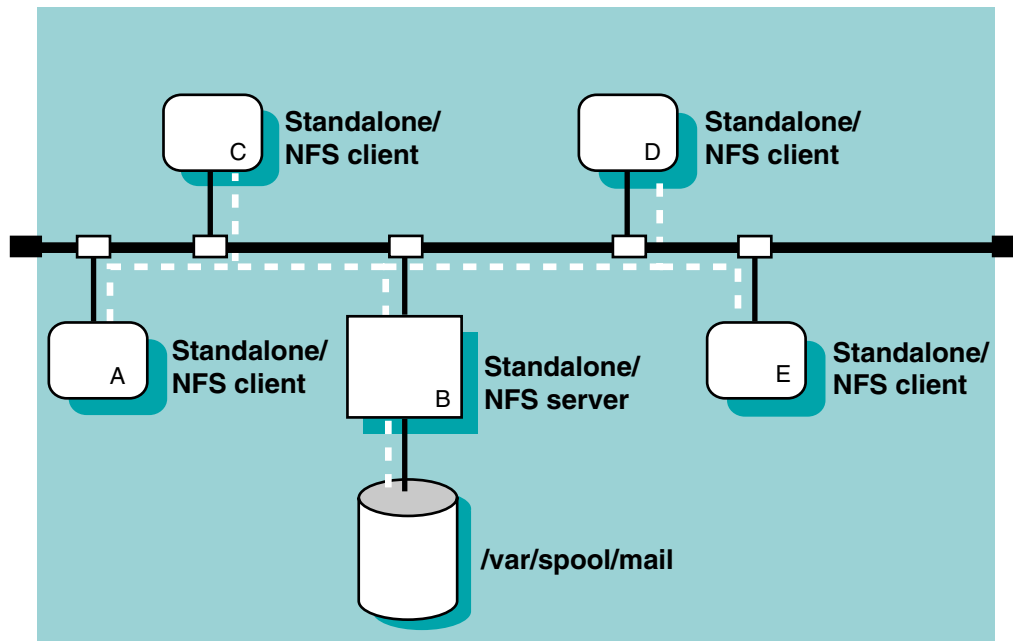

ZK-1156U-AI

Figure 7–2 shows a sample client/server configuration in which host B is configured as a mail server and hosts A, C, D, and E are configured as mail clients. This is useful in larger enterprise networks that consist of multiple domains and connections to the Internet or other networks.

This configuration also provides for the creation of a natural hierarchy of mail servers in large enterprise networks with multiple domains. Mail clients in each domain direct all traffic to one or more mail servers, depending on the number of clients in the domain. Each domain's servers then forward mail to the enterprise's top domain servers for forwarding to the Internet. Since almost all of your local domain's mail traffic goes through the servers, this simplifies administration and problem resolution in that you have to manage only the servers.

The connection to the Internet in Figure 7–2 can be direct or through a local access provider. Business configurations typically use firewalls and dedicated mail servers. If using a firewall, ensure the firewall and the mail server are configured to work with each other. See the documentation for your firewall product for more information.

**Figure 7–2: Sample Mail Client/Server Configuration**

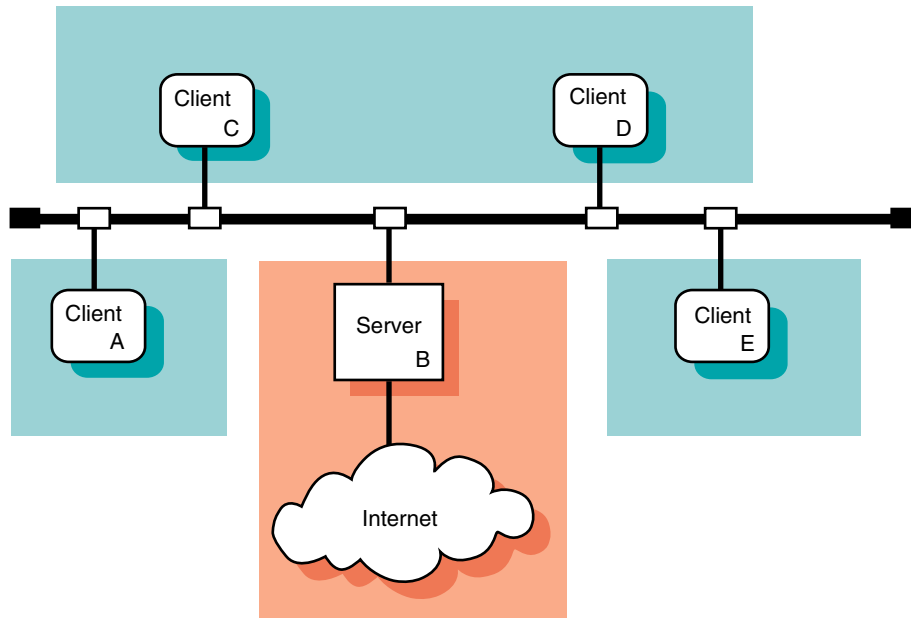

ZK-1157U-AI

If users need to send mail between systems that use different mail protocols, such as the Simple Mail Transfer Protocol (SMTP), UNIX-to-UNIX Copy Program (UUCP), and DECnet, it is best to designate specific server systems in your network to perform those functions. These server systems are also known as mail relays.

Additional mail configurations are possible, but they require more effort to plan for and to configure. See the *sendmail* book by O'Reilly and Associates and the *Sendmail Installation and Operation Guide* for more information.

In implementing a client/server mail environment, you need to decide how to do the following:

- Direct outgoing mail to the servers
- Handle incoming mail to the domain
- Deliver mail to clients
- Distribute the `aliases` file
- Distribute the `passwd` file
- Handle DECnet mail

This section describes each of these topics.

### 7.1.1 Directing Outgoing Mail to Servers

To direct outgoing mail to a server, you include the DNS mail exchanger (MX) entry in the `/etc/namedb/hosts.db` file. This entry specifies a system in the local domain that can deliver mail to other systems, especially those not directly connected to the local network. Using MX to route mail has the following benefits:

- You can define an MX record to point to all of the mail servers in your local domain. If a mail server is inaccessible, mail can be delivered to another host listed in the MX record.
- You can use MX records to define a system to be a mail exchanger for an inaccessible remote system. Then, if you send mail to the remote, inaccessible host, instead of being queued on your local system and periodically resent, the mail is sent to the mail exchanger and queued there until the host is restored.

For information on adding entries to the `/etc/namedb/hosts.db` file, see Section 2.8.2, Appendix G, and `bind_manual_setup(7)`.

### 7.1.2 Handling Incoming Mail to the Domain

To simplify the handling of incoming mail to a domain and to ensure reliability, use domain-based addresses in your environment. Mail sent over the Internet is usually addressed in the following format:

*username@hostname.domain*

For example: `joe@host1.nyc.big.com`

Using domain-based addresses, this address appears as follows:

`joe@nyc.big.com`

Mail is sent to the local domain `nyc.big.com` instead of to the specific host within that domain `host1.nyc.big.com`; the return address is also `@nyc.big.com`. Then, the mail servers within the local domain decide how to deliver the mail to the user's account.

Domain-based addresses make it easier to manage your mail environment. You can change your mail system (that is, move user accounts and replace or move systems) without disrupting your mail delivery. These changes are transparent to users sending mail to your systems.

### 7.1.3 Delivering Mail to Clients

Once mail is delivered to the domain, you can deliver it to clients using one of the following mechanisms:

- Deliver the mail to the `/var/spool/mail` directory on each client, which is the default
- Deliver the mail to the server and use NFS to serve the mail directory to each client
- Deliver the mail from a server to a local client machine using POP (see Section 7.4)
- Deliver the mail to a server using IMAP (see Section 7.5)

To deliver mail to each client, each server in the domain must have an `aliases` file that contains an entry for each user on the client. For example:

```
username1: username1@client1
username2: username2@client1
```

#### 7.1.4 Distributing the `aliases` File

For standalone and server systems, use the Network Information System (NIS) to distribute the mail `aliases` file from one machine. In a LAN environment with standalone systems, distribute the mail `aliases` file from the NFS server system. In a client/server environment, distribute the `aliases` file to the servers in the domain. In any case, sharing the `aliases` file among systems simplifies administration in that you need to update only one `aliases` file, instead of several.

See `aliases(4)` for more information about the database. See Section 7.6.3 and Chapter 3 for information about distributing the database with NIS.

#### 7.1.5 Distributing the `passwd` File

If you have multiple server systems in a domain, make sure that the information in the `passwd` file is identical on each system. For security reasons and to ensure correct mail delivery, it is best to do this by manually editing the `passwd` file on each server system.

#### 7.1.6 Handling DECnet Mail

When you set up a mail server system, you must consider that the mail address formats for DECnet Phase IV and DECnet/OSI are different from those for TCP/IP. Therefore, you need to establish a mapping scheme to translate mail addresses when sending mail between a DECnet node and a TCP/IP node.

The mapping scheme used by the Tru64 UNIX version of the `sendmail` program for DECnet Phase IV encapsulates DECnet addresses inside a pseudomain. For example, a typical DECnet Phase IV address has the following format:

*nodename::username*

Mail addressed in this format is mapped to an address in the following format:

*username@nodename.pseudodomain.top.domain*

The variables represent the following:

*username*

The user name.

*nodename*

The DECnet node name.

*pseudodomain*

An arbitrary string that specifies the DECnet pseudodomain. The pseudodomain can be an arbitrary string, but it must be used consistently throughout your organization. All of your mail systems must be configured to use the same string for the pseudodomain.

*top.domain*

Usually, your company's domain name; for example, *abc.com*.

The mapping for DECnet/OSI uses a similar scheme. A typical DECnet/OSI address has the following format:

*username@namespace:.site.nodename*

Mail addressed in this format is mapped as follows:

*username@nodename.site.namespace.pseudodomain.top.domain*

As with DECnet Phase IV, the pseudodomain can be an arbitrary string. However, if you use both DECnet Phase IV and DECnet/OSI within your organization, it is best to use different pseudodomain names.

Some environments that support both DECnet Phase IV and DECnet/OSI use the DECnet Phase IV syntax to handle DECnet-based mail. This simplifies the mail administration task. In order to implement this, all DECnet-OSI nodes must have a unique Phase IV Synonym and must be configured to use the Phase IV Synonym. You can reconfigure a DECnet/OSI host by typing the following command line:

```
# ncl set session control application mail111 Node Synonym=true
```

See the DECnet/OSI documentation for more information.

## 7.2 Planning Mail

This section describes those tasks you need to do before configuring mail.

### 7.2.1 Verifying That Required Protocols Are Installed

Depending on the protocols supported by your mail server, verify that the following required subsets are installed and configured:

- DECnet
- DECnet/OSI
- X.25 (PSInet)
- UUCP

See the documentation for each product for installation and configuration instructions. For UUCP, verify that the UUCP subset is installed by entering the following command:

```
# setld -i | grep OSFUUCP
```

If it is not installed, install it by using the `setld` command. For more information on installing subsets, see `setld(8)` or the *Installation Guide*.

### 7.2.2 Verifying That Required Services Are Configured

The following table lists specific mail configurations and the network service required:

| <b>If you want to:</b>      | <b>Configure this service:</b> |
|-----------------------------|--------------------------------|
| Distribute the aliases file | NIS                            |
| Use domain-based addressing | DNS/BIND                       |

If NIS is needed, enter the following command as root to verify that NIS is configured:

```
# rcmgr get NIS_CONF
```

If the command returns `NO`, then NIS is not configured. See Chapter 3 for instructions on how to configure NIS and distribute the `aliases` file.

If DNS is needed, enter the following command as root to verify that DNS is configured:

```
# rcmgr get BIND_SERVERTYPE
```

If the command returns nothing, then DNS is not configured. See Chapter 2 for instructions on how to configure DNS.



## 7.2.3 Preparing for the Configuration

After you install and configure the required protocols and services, you configure mail using the Mail Configuration application.

Mail configuration consists of:

- Defining the standalone, client, or server system
- Defining the protocol information (server systems only)

The following sections contain worksheets that you can use to record the information required to configure mail.

### 7.2.3.1 General System Information

Figure 7–3 shows the Basic Mail Setup Worksheet. If you are viewing this manual online, you can use the print feature to print a copy of this worksheet. The following sections explain the information you need to record on the worksheet.

**Figure 7–3: Basic Mail Setup Worksheet**

| Basic Mail Setup Worksheet  |                                |                                     |                                     |
|-----------------------------|--------------------------------|-------------------------------------|-------------------------------------|
| Mail server (clients only): | _____                          |                                     |                                     |
| Top domain (servers only):  | _____                          |                                     |                                     |
| Mailbox directory:          | <input type="checkbox"/> Local | <input type="checkbox"/> NFS client | <input type="checkbox"/> NFS server |
| Locking:                    | <input type="checkbox"/> lockf | <input type="checkbox"/> Lock file  | <input type="checkbox"/> Both       |
| Mailbox server:             | _____                          |                                     |                                     |

#### Mail server (clients only)

The fully qualified name of your mail server; for example, `foo.dec.com`. Or, the name of your domain; for example, `dec.com`, if you are using domain-based routing. It is advantageous to specify the domain name itself because your mail service cannot be interrupted by a single mail server that becomes unavailable.

#### Top domain (servers only)

The name of the highest level domain in your organization that uniquely identifies your organization. For example, if the server domain name is `nyc.big.com`, the top domain is `big.com`. If the server domain name is `cs.big.univ.ac.uk`, the top domain is `big.univ.ac.uk`.

#### Mailbox directory

The location of the mailbox directory.

For standalone and client systems, if the mailbox directory is on the local system, check Local. If it is on a remote system and is to be mounted on the local system using NFS, check NFS Client. If the local system is to export mail boxes to NFS clients, check NFS Server.

For server systems, check Server to make the mailbox directories available to other systems. If you do not want to share the mailbox directories, check Local. In this case, use the `aliases` file to send each user's mail to the appropriate system. See Section 7.6.3 and `aliases(4)` for more information.

## Locking

The type of file locking to use on the mailbox.

For standalone and client systems, if the host with the mailbox directory is a Tru64 UNIX system, check `lockf`; this provides the best performance. If you are not sure what operating system the host with the mailbox directory is running, check Lock file. If you want to use both, check Both.

---

### Note

---

The locking mechanism you select must match the mechanism used by the NFS server. If you are not sure how the locking mechanisms are set on the NFS server, ask the administrator of the NFS server.

---

For server systems, if you checked Local as the mailbox location, check `lockf`. If you checked Client as the mailbox location, check Lock file. If you checked Server as the mailbox location, check Both.

## Mailbox server

The name of the system that exports the mailbox to your local system.

### 7.2.3.2 Protocol Information

Figure 7–4 shows the Mail Protocol Worksheet. If you are viewing this manual online, you can use the print feature to print a copy of this worksheet. The following sections explain the information you need to record on the worksheet.

**Figure 7–4: Mail Protocol Worksheet**

| Mail Protocol Worksheet |  |
|-------------------------|--|
| <b>Internet (SMTP)</b>  | Forward: <input type="checkbox"/> None <input type="checkbox"/> Internet<br><input type="checkbox"/> Nonlocal <input type="checkbox"/> Local   |
|                         | Relay's host name: _____   |
|                         | Relay's protocol: _____  |
|                         | Pseudodomain: _____  |
|                         | Pseudodomain aliases: _____  |
|                         | Host aliases: _____  |
| <b>Others</b>           | Protocol: <input type="checkbox"/> DECnet <input type="checkbox"/> DECnet/OSI <input type="checkbox"/> POP3<br><input type="checkbox"/> MTS <input type="checkbox"/> UUCP <input type="checkbox"/> X.25 <input type="checkbox"/> IMAP4 |
|                         | Routing: <input type="checkbox"/> Internet <input type="checkbox"/> Direct <input type="checkbox"/> Relay  |
|                         | Relay's host name: _____   |
|                         | Relay's protocol: _____  |
|                         | Node address (DECnet): _____   |
|                         | DNS name space (DECnet/OSI): _____   |
|                         | Pseudodomain: _____  |
|                         | Pseudodomain aliases: _____  |
|                         | Host aliases: _____  |

To configure your system as an Internet (SMTP) server, you need to collect the following information:

**Forward**

The type of mail that must be forwarded to a relay. If the local host has direct access to the Internet and does not forward any mail, check None. If the local host must forward all mail addressed outside of the top domain, check Internet. If the local host must forward all messages addressed outside of the local Internet domain, check Nonlocal. If the local host must forward all mail, including local domain mail, check Local.

**Relay's host name**

The name of the remote host that will process SMTP mail.

**Relay's protocol**

The name of the protocol the server uses to forward messages to the relay host.

## **Pseudodomain**

An arbitrary string that specifies the pseudodomain for SMTP mail. The pseudodomain name must be unique for each protocol and must be used consistently throughout your enterprise.

## **Pseudodomain aliases**

Any synonyms for your pseudodomain.

## **Host aliases**

The alternative names that other systems might use to direct mail to your host.

To configure your system as a server for other mail protocols, you need to collect the following information:

## **Protocol**

The type of mail protocols to use. Available protocols include the following:

- DECnet (Phase IV)
- DECnet/OSI (Phase V)
- Internet Mail Protocol (SMTP) (required)
- Internet Message Access Protocol (IMAP)
- Message Transport System (MTS)
- Post Office Protocol (POP)
- UUCP
- X.25 (PSInet)

## **Routing**

For DECnet, DECnet/OSI, UUCP, MTS, and X.25 only. If mail for the particular protocol is to be forwarded over the Internet to an unspecified gateway, check Internet. The Internet depends on DNS to select an appropriate relay; therefore, do not specify a relay hostname for the Internet.

If the particular protocol is installed on this server, check Direct. If mail requiring the particular protocol is to be forwarded to another system for processing, check Relay. Complete the Relay's hostname and Relay's protocol fields.

**Relay's host name**

The name of the remote host that will process mail for the protocol.

**Relay's protocol**

The name of the protocol the server uses to forward messages to the relay host.

**Node address (DECnet)**

The address for this machine (DECnet only).

**DNS name space (DECnet/OSI)**

The complete DNS name space name for this node (DECnet/OSI only). The syntax of the DNS name space is as follows:

*namespace::site.nodename*

**Pseudodomain**

An arbitrary string that specifies the pseudodomain (DECnet, DECnet/OSI, and MTS only). The pseudodomain name must be unique for each protocol and must be used consistently throughout your enterprise.

**Pseudodomain aliases**

Any synonyms for your pseudodomain (DECnet, DECnet/OSI, UUCP, and MTS only).

**Host aliases**

The alternative names that other systems might use to direct mail to your host.

## 7.3 Configuring Mail

Use the Mail Configuration application of the Common Desktop Environment (CDE) Application Manager to configure mail on systems with graphics capabilities.

---

**Note**

---

Alternatively, you can use the SysMan Menu (`/usr/sbin/sysman mailsetup`) or the `mailsetup` utility to configure mail on

your system. See the online help and `mailsetup(8)` for more information.

---

You can configure the following systems:

- Standalone systems
- Client systems
- Server systems

To start the Mail Configuration application, do the following:

1. Log in as root.
2. Click on the Application Manager icon on the CDE desktop.
3. Double-click on the System\_Admin application group icon.
4. Double-click on the Configuration application group icon.
5. Double-click on the Mail Configuration application icon in the Configuration group. The Mail Configuration main window is displayed, showing available Mail service types and configured Mail service types.

To exit the Mail Configuration application, choose File then Exit. See `mailconfig(8)` for more information.

The Mail Configuration application has an extensive online help system that you can use, instead of the instructions in this section, to configure mail on your system.

### 7.3.1 Configuring a Standalone Mail System

To configure mail for a standalone system, do the following:

1. Select Standalone from the Available Mail Service Types list box in the Mail Configuration window
2. Select Configure to display the Standalone Setup dialog box.
3. Select Mailbox Setup to display the Mailbox Setup dialog box if your site uses NFS to import or export system mailbox directories (for instance, `/var/spool/mail`); otherwise, go to step 7, the default settings are applicable for your mail configuration.
4. If your system imports its mailbox using NFS, select the NFS Client radio button and do the following:
  - a. Enter the server name in the Mailbox Server field.
  - b. Select a radio button for the appropriate Locking mechanism: lockf, Lock Files, or Both.

5. If your system distributes mailboxes to NFS clients, select the NFS Server radio button, then select the Both radio button for the Locking Mechanism setting.
6. Select OK to complete the mailbox setup and close the Mailbox Setup dialog box.
7. Select Commit to save the changes. You are asked if you would like to restart the `sendmail` daemon.
8. Select Restart to start the `sendmail` daemon and apply your changes immediately. Or, select No to apply the changes the next time you reboot your system.  
  
If you choose Restart, you are informed that the `sendmail` daemon has been started. Select OK to dismiss the message.
9. Select Close to close the Standalone Setup dialog box.

### 7.3.2 Configuring a Mail Client

To configure a mail client, do the following:

1. Select Client from the Available Mail Service Types list box in the Mail Configuration window.
2. Select Configure to display the Client Setup dialog box.
3. Enter the name of a mail server for outgoing mail in the Mail Server field.
4. Select Mailbox Setup to display the Mailbox Setup dialog box.
5. Select the NFS Client radio button for the Mailbox Directory if your site uses NFS to share system mailbox directories; otherwise, select Local and go to step 7.
6. Enter the name of the server that exports the mailbox directory to your system in the Mailbox Server field.
7. Select a radio button for the appropriate Locking mechanism: lockf, Lock Files, or Both.
8. Select OK to complete the mailbox setup and to close the Mailbox Setup dialog box.
9. Select Commit to save the changes. You are asked if you would like to restart the `sendmail` daemon.
10. Select Restart to start the `sendmail` daemon and apply your changes immediately. Or, select No to apply the changes the next time you reboot your system.

If you choose Restart, you are informed that the `sendmail` daemon has been started. Select OK to dismiss the message.

11. Select Close to close the Client Setup dialog box.

### 7.3.3 Configuring a Mail Server

To configure a mail server, follow these steps. If you intend to implement the POP or IMAP daemons, configure SMTP and other necessary protocols first, then see Section 7.4 and Section 7.5.

1. Select Server from the Available Mail Service Types list box in the Mail Configuration window.
2. Select Configure to display the Server Setup dialog box.
3. Select the mail protocol you want to configure from the Available Protocols list box. The Internet Mail Protocol (SMTP) protocol is the only required protocol configuration. Configure additional protocols as necessary.
4. Select Configure to display the protocol setup dialog box for the protocol you selected.
5. For the SMTP protocol, select the type of forwarding for this server. If you select None, go to step 11; otherwise, go to step 7.
6. For the DECnet, DECnet/OSI, MTS, UUCP, and X.25 protocols, select a Routing type. If you select Internet or Direct, go to step 9. If you select Relay, go to step 7.
7. Enter a host name in the Relay's Hostname field if you will be forwarding mail to another system for processing; otherwise, continue with step 9.
8. Select the protocol used to communicate with the relay in the Relay's Protocol pulldown menu.
9. For the DECnet, DECnet/OSI, and MTS protocols, in the Pseudo Domain field, enter the domain name used to identify mail that requires the selected protocol.
10. For the DECnet, DECnet/OSI, MTS, UUCP, and X.25 protocols, to add aliases for the pseudodomain, select Pseudo Domain Aliases to display the Pseudo Domain Aliases dialog box, and do the following:
  - a. Enter the alias name in the Pseudo Domain Alias field and select Add.
  - b. Repeat the previous step as many times as necessary.
  - c. Select OK to close the Pseudo Domain Aliases dialog box.



11. To add aliases for this mail server, select Host Alias to display the Host Aliases dialog box, and do the following:
  - a. Enter the alias name in the Host Alias field and select Add.
  - b. Repeat the previous step as many times as necessary.
  - c. Select OK to close the Host Aliases dialog box.
12. For the DECnet protocol, enter the DECnet node address (area.node) for this server in the Node Address field, for example, 32.958.
13. For the DECnet/OSI protocol, enter the name space of the node, which is usually the token before the colon (:) in a DECnet Phase V address, in the DNS Name Space field.
14. Select OK to close the Setup dialog box for the protocol you selected. The Server Setup dialog box is active.
15. Configure another protocol if necessary. Repeat steps 3 through 15 for each additional protocol.
16. Select Mailbox Setup to display the Mailbox Setup dialog box.
17. Select a radio button for Mailbox Directory.

If your site does not use NFS to distribute the system mailbox directories, select Local instead of NFS Server, and then go to step 19.
18. If you selected NFS Client as a Mailbox Directory, enter the name of the mail server in the Mail Server field. Be sure to include the domain. For example, for a server named mailhub, the server name with domain might be mailhub.nyc.dec.com.
19. Select a radio button for the appropriate Locking mechanism: lockf, Lock Files, or Both.
20. Select OK to complete the mailbox setup and close the Mailbox Setup dialog box.
21. Select Commit to save the changes. You are prompted to restart the sendmail daemon.
22. Select Restart to start the sendmail daemon and apply your changes immediately. Or, select No to apply the changes the next time you reboot your system.

If you choose Restart, you are informed that the sendmail daemon has been started. Select OK to dismiss the message.
23. Select Close to close the Server Setup dialog box.
24. Add DNS mail exchanger (MX) records to the `/etc/namedb/hosts.db` file for each host in your environment, if necessary. See Section 7.1.1 for more information.

### 7.3.4 Adding a New Mail Host

To add a new mail host to your existing mail environment, do the following:

1. Configure the network and network services on the host. See *Network Administration: Connections* for more information.
2. If you are using DNS MX records in your environment, update the DNS data files. See Section 7.1.1 for more information.

## 7.4 Post Office Protocol

The Post Office Protocol Version 3 (POP3 or POP) is a client/server protocol that allows users to download their e-mail from a mail server to a remote client. It is intended for users that mainly access their e-mail in an offline mode. In offline mode, messages are delivered to a server and reside there until the user connects to the server and downloads the incoming messages to the client machine (a desktop or laptop computer running Windows, Macintosh, UNIX, or another operating system). Thereafter, all message processing is local to the client machine and environment. This is the mode used widely today by Internet Service Providers (ISPs) to provide e-mail services for their consumers. See `pop3d(8)` for further information.

### 7.4.1 Installing POP

The operating system provides a POP3 server (`/usr/sbin/pop3d`) from Qualcomm, Incorporated, which is fully installed and configured for you when you install the `OSFINET` subset (check the installation log file for any warnings or errors). The `pop3d` daemon is configured to listen on port 110 for incoming connections, and allows any user of the system to access their e-mail via a POP client.

During installation, the `/etc/passwd`, `/etc/services`, and `/etc/inetd.conf` configuration files are updated. If the lines displayed in the following examples are not present in the configuration files, the POP3 service may not behave appropriately. If a previous version of POP was detected, or if the `OSFINET` subset did not install properly, the files might not have been updated and the changes must be made manually.

The `/etc/passwd` file must contain the following line; if it does not, add the line to the file:

```
pop:*:13:6:POP Mail Service Account:/:
```

If necessary, change the user identification number, 13, to a value that is appropriate for your system.

The `/etc/services` file must contain the following line; if it does not, add the line to the file:

```
pop3    110/tcp
```

The `/etc/inetd.conf` file must contain the following line; if it does not, add the line to the file:

```
pop3    stream  tcp    nowait  root    /usr/sbin/pop3d    pop3d
```

## 7.4.2 Migrating to the New POP3 Implementation

The POP service was upgraded in Tru64 UNIX Version 5.0. Migration paths are provided for systems that were running either the version of POP3 offered with the OSFMH (RAND Corp. Mail Handler) subset or the Qualcomm POP3 service (if your version came directly from Qualcomm).

If you use the MH POP3 service, you must migrate your POP user accounts from the `/usr/spool/pop/POP` file to the `mailauth` database and convert your mailboxes to the new format.

If you use the Qualcomm POP3 service, you must migrate your POP user accounts from the `popauth` database to the `mailauth` database; however, you do not need to convert your mailboxes. The only difference between Qualcomm POP3 and the Tru64 UNIX implementation of Qualcomm POP3 is the mail authorization database, which has been enhanced to store secondary POP and IMAP passwords.

The following sections describe the migration paths for each service. See `popcv(8)` for further information.

### 7.4.2.1 Migrating from MH POP3

To migrate from MH POP3 service to the new implementation, complete the following tasks:

1. Remove any startup scripts for the `/usr/lib/mh/popd` file in the `/sbin/rc` directories.
2. Make sure that the `/etc/inetd.conf` and `/etc/services` configuration files were updated with the correct entries as described in Section 7.4.1.
3. Initialize the `mailauth` database by entering the following command:  

```
# /usr/bin/mailauth -init
```
4. Use the `popcv` utility to move usernames and passwords from the `/usr/spool/pop/POP` file to the `mailauth` database (`/etc/pop.auth.pag` and `/etc/pop.auth.dir`). Enter the following command, where `filename` can be an alternate file used to store POP passwords:  

```
# /usr/bin/popcv [filename]
```

5. Use the `mailcv` tool to convert existing MH POP3 mail folders to the new POP3 format:

- a. Change directory to the MH POP3 mail folder directory:

```
# cd /usr/spool/mail/POP
```

The directory might be `/usr/spool/pop` or another directory depending on how you configured MH POP3.

- b. For each mail user, enter the following command, where `input` is the file name of the user's MH POP3 folder:

```
# /usr/dt/bin/mailcv -Q -f input
```

Typically, the file name is the same as the POP user's username. For instance, for a user named Jake, you would convert the `/usr/spool/mail/POP/jake` file.

Optionally, you can change the name of a mail folder during the conversion process by appending the new file name to the end of the command, as in the following example:

```
# /usr/dt/bin/mailcv -Q -f charlie chuck
```

See `mailcv(1)` for more information.

#### 7.4.2.2 Migrating from Qualcomm POP3

To migrate from Qualcomm's POP3 service to the new implementation, complete the following tasks:

1. Ensure that the `/etc/inetd.conf` and `/etc/services` configuration files were updated with the correct entries as described in Section 7.4.1.
2. If a previous `popauth` database exists, convert it to a `mailauth` database by using the following command:

```
# /usr/bin/mailauth -convert
```

You need to convert your mail folders only if you previously ran the MH POP3 server.

#### 7.4.3 Configuring a POP Mail Account

To configure a POP mail account, create a UNIX account for the user (if one does not already exist) as described in the *System Administration* manual. The user's mailbox is set up automatically.

Once the user's account is set up on the server, the user can configure a mail application compatible with POP3, for example, Netscape Communicator, which is bundled with the operating system software. At a minimum, you

must provide the user with the following information about mail service in your facility:

- POP username — Specify if different from the UNIX username.
- POP-specific password — Specify if different from the UNIX password.
- POP server name — The mail application collects incoming mail from this server.
- SMTP server name — The mail application delivers outgoing mail to this server.
- Domain name — The mail application adds this domain name to all unqualified addresses for domain-based mail addressing.

#### 7.4.4 Changing Login Authentication

The POP service typically authenticates user accounts by verifying the supplied user name and password against information in the UNIX password file (usually the `/etc/passwd` file). The Tru64 UNIX implementation of POP has been enhanced to optionally support SIA interfaces for authentication on a C2 secure system.

For increased security, the system administrator can have POP users use alternate passwords instead of their usual login passwords; therefore, if a POP password is compromised across the network, system access is not at risk.

There are two ways to enable alternate passwords for POP authentication:

- Arrange for POP users to store alternate passwords in the `mailauth` database (`/etc/pop.auth.dir` and `/etc/pop.auth.pag`).
- Add mail users to the same `mailauth` database as Authenticated POP (APOP) users. APOP uses an encrypted authentication mechanism, also with alternate passwords, that is more secure than standard POP; however, users need mail client applications compatible with APOP to take advantage of it.

Use the SysMan Menu application of the Common Desktop Environment (CDE) Application Manager to enable either authentication option. To invoke the SysMan Menu application, follow the instructions in Section 1.2.1, then follow these steps:

---

#### Note

---

If users in your environment use one of the old POP3 implementations, you must migrate them to the new POP3

implementation as described in Section 7.4.2 prior to enabling alternate passwords.

---

1. From the SysMan Menu, select Mail→Manage users' mail accounts. The Mail User Administration window is displayed. Optionally, you can invoke this utility by executing the following command:

```
# sysman mailusradm &
```

2. Select the radio button for List Specific Users and select Compile List.
3. Enter the username or a wildcard in the dialog box and select OK.
4. Select the name of the user for whom you would like to require an alternate password.
5. Select the desired mail service type from the pulldown menu. To require that the user use an alternate password for POP mail, select POP with Mail Password. To switch the user's mail service to APOP, select APOP with Mail Password.
6. Select OK to save your changes.
7. Enter an alternate password for POP or APOP and select OK.

The user can later set a new password by issuing the `mailauth` command without any options. For example:

```
% /usr/bin/mailauth
```

8. Select OK to dismiss the message that indicates that the account has been modified successfully.
9. Select Exit to close the Mail User Administration window.

If you need to change authentication for multiple accounts, you can select List All Local Mail Users in step 2. Hold down the Ctrl key and click the right mouse button to select more than one user name from the list. See `mailusradm(8)` for more information about the Mail User Administration utility.

Optionally, you can use the `mailauth` utility to set up authentication. See `mailauth(8)`.

## 7.4.5 Administrative Tools

You can use the following tools to administer the POP service:

- `mailauth` — Utility used to manage the secondary mail authorization database. See `mailauth(8)`.
- `mailusradm` — System administration GUI utility used to configure mail users. See `mailusradm(8)`.

The POP server sends log messages to the `syslogd` daemon. The log information is stored in the `/var/adm/syslog.dated/date/mail.log` file. You can use this data to solve problems. The severity levels are `NOTICE` for failed and successful authentications and `DEBUG` for all debugging information.

## 7.4.6 Directory Structure

The POP configuration and mail files are distributed across the file system as indicated in Figure 7–5.

**Figure 7–5: POP Directory Structure**

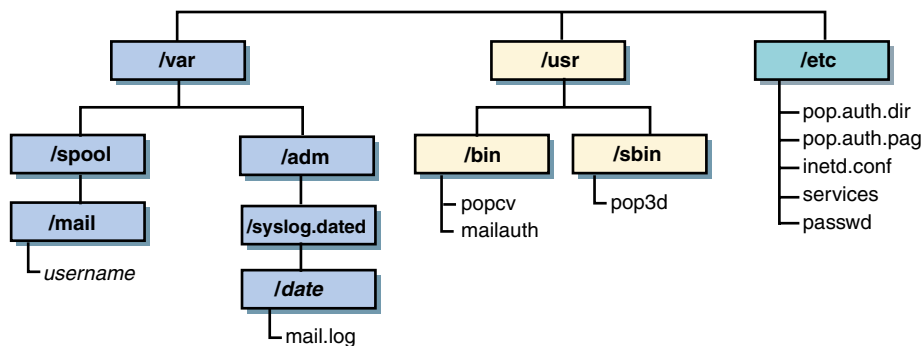

ZK-1540U-AI

Table 7–1 describes the purpose of these files and directories.

**Table 7–1: POP3 Files and Directories**

| File or Directory                      | Purpose   |
|--|---|
| <code>/etc/passwd</code> file          | Contains account information for each user on the system. Users configured in this file are able to use POP mail by default.  |
| <code>/etc/pop.auth.*</code> files     | Contain the encrypted mail authorization database, which is used to authenticate POP and IMAP users. See <code>mailusradm(8)</code> and <code>mailauth(8)</code> for information about editing this database. |
| <code>/var/spool/mail</code> directory | Contains the mail folders for all POP and UNIX mail users on the system. Each folder is a file with a file name that is usually identical to the user's login name.   |

## 7.5 Internet Message Access Protocol

The Internet Message Access Protocol Version 4 (IMAP4 or IMAP) is a client/server protocol that allows mail clients to access mail messages on a server. With it, the user can access mail folders and manipulate the contents remotely without having to log in to the server. The protocol allows clients to create, delete, and rename mail folders, to check for new messages and remove old messages, and to selectively retrieve messages for local viewing. In addition, the user can select messages by attributes and parse messages in the RFC 822 and MIME formats.

This protocol can be used in the offline, online, or disconnected mode. The offline mode is the same as that described in Section 7.4. In online mode, messages are manipulated on the server remotely by mail client programs. In disconnected mode, a mail client connects to the mail server, makes a cache copy of selected messages, and then disconnects from the server, later to reconnect and resynchronize with the server. In both online and disconnected access modes, mail is stored on the server, which is often a necessity for people who use different computers at different times to access their messages.

See `imapd(8)`, `deliver(8)`, and `imapd.conf(4)` for further information.

### 7.5.1 Installing IMAP

The operating system software includes the Cyrus IMAP4 Revision 1 server (`/usr/sbin/imapd`) by Carnegie Mellon University, which is installed and configured when you install the `OSFINET` subset (check the installation log file for any warnings or errors). The `imapd` daemon is configured to listen on port 143 for incoming connections.

During installation, the `/etc/passwd`, `/etc/services`, and `/etc/inetd.conf` configuration files are updated. If the lines specified in the following examples are not present in the configuration files, the IMAP service might not behave appropriately.

The `/etc/passwd` file must contain the following line; if it does not, add the line to the file:

```
imap:*:14:6:IMAP Mail Service Account:/:
```

If necessary, change the user identification number, 14, to a value that is appropriate for your system.

The `/etc/services` file must contain the following line. If it does not, add the line to the file:

```
imap    143/tcp
```



The `/etc/inetd.conf` file must contain the following line. If it does not, add the line to the file:

```
imap    stream  tcp    nowait  imap    /usr/sbin/imapd    imapd
```

## 7.5.2 Upgrading IMAP

Starting with Version 1.6.1 of the Cyrus IMAP4 Revision 1 server, the IMAP files in the `quota` and `user` configuration directories, and optionally, the users' mail directories in the IMAP mail spool, are stored in subdirectories a through z, sorted by the first character of each user name. This arrangement reduces the number of entries in a given directory and consequently increases performance and scalability.

If you are running the IMAP server from a previous version of the operating system, and you are upgrading to Tru64 UNIX Version 5.1, you must convert your `quota` and `user` configuration directories to the new format. Optionally, you can sort your IMAP mail spool in the same manner by enabling the `hashimapspool` option in the `/etc/imapd.conf` file before converting your configuration directories. See `imapd.conf(4)` for more information.

To convert your directories to the new format, use the `dohash` utility. See `dohash(8)` for more information.

## 7.5.3 Configuring IMAP Mail Accounts

To enable users to receive IMAP mail, you must complete two tasks. First, if the users do not have accounts on the system, you must create them. See the *System Administration* manual and `adduser(8)` for more information.

Second, you must change the properties of the users' accounts to indicate that their mail is to be processed by the IMAP server. Use the SysMan Menu application of the Common Desktop Environment (CDE) Application Manager to configure the user's mail service type. To invoke the SysMan Menu application, follow the instructions in Section 1.2.1.

To change the user's mail service type, do the following:

1. From the SysMan Menu, select Mail→Manage users' mail accounts. The Mail User Administration window is displayed. Optionally, you can invoke this application by executing the following command:

```
# sysman mailusradm &
```

2. Select the radio button for List Specific Users and select Compile List.
3. Enter the username or a wildcard in the dialog box and select OK.

4. Select the name of the user whose mail service type you would like to change from the list.
5. Select the desired mail service type from the pulldown menu. To require that the user use an alternate password for IMAP mail, select IMAP with Mail Password. Otherwise, select IMAP to use the same password.  
  
If you enable this option, the alternate passwords are stored in the `mailauth` database, which is located in the `/etc/pop.auth.dir` and `/etc/pop.auth.pag` files. See `mailauth(8)` for more information.
6. Select OK to save your changes.
7. Enter the mail administrator's password. In most cases, this password is the same as the root account password. Select OK.
8. Select the privileges to set on the user's mailbox. In most cases, you will select All to allow the user to read, modify, and delete messages in the mailbox. Select OK.  
  
If you did not select IMAP with Mail Password in step 5, skip to step 10.
9. Enter an alternate password for IMAP and select OK.  
  
The user can later select a new password by issuing the `mailauth` command without any options. For example:  
  

```
% /usr/bin/mailauth
```
10. Select OK to dismiss the message that indicates that the account has been modified successfully.
11. Select Exit to close the Mail User Administration window.

If you need to set up multiple IMAP accounts, you can select List All Local Mail Users in step 2. Hold down the Ctrl key and click the right mouse button to select more than one user name from the list.

See the online help and `mailusradm(8)` for more information.

Once a user's IMAP account is set up on the server side, the user can configure a mail application compatible with IMAP4, for example, Netscape Communicator, which is bundled with the operating system software. At a minimum, you must provide the user with the following information about mail service in your facility:

- IMAP username — Specify if different from the UNIX username.
- IMAP password — Specify if different from the UNIX password.
- IMAP Mailbox location prefix — `user.username`
- IMAP server name — The mail application collects incoming mail from this server.

- SMTP server name — The mail application delivers outgoing mail to this server.
- Domain name — The mail application adds this domain name to all unqualified addresses for domain-based mail addressing.

## 7.5.4 Migrating Users from UNIX and POP3 Mail

To convert an existing UNIX or POP3 mail user to IMAP mail, you must first set up the user's IMAP account as described in Section 7.5.3. Then, use the `mailcv` tool to convert the user's mail folder to the IMAP format as follows:

---

### Note

---

If you are using MH POP3 or a version of Qualcomm POP3 that did not come with the operating system software, follow the instructions in Section 7.4.2 to convert to the new POP3 implementation before converting to IMAP.

---

1. Change directory to the UNIX/POP3 mail folder directory:

```
# cd /usr/spool/mail
```

2. Assume the user's identity by using the `su` command, as follows:

```
# su username
```

You must be the user to convert the user's mail folder to IMAP format with the `mailcv` command.

3. Enter the following command, where *folder* is the file name of the user's mail folder:

```
% /usr/dt/bin/mailcv -I -f folder
```

You need the user's IMAP password to use this command.

The mail folder file name is usually the same as the user's username. For instance, for a user named Jake, you would convert the `jake` file.

Optionally, you can move the converted messages to an IMAP subfolder during the conversion process by appending a subfolder name to the end of the command, as in the following example:

```
# /usr/dt/bin/mailcv -I -f charlie business
```

IMAP subfolders are described in Section 7.5.7. See `mailcv(1)` for more information about the `mailcv` command.

4. Exit the `su` session to the user's account, as follows:

```
% exit
#
```

Mail received after the account is changed to IMAP but prior to the conversion process is not lost. The newly-converted messages are appended to the existing messages in the user's mailbox.

Once a user's UNIX or POP account is converted to an IMAP account on the server, the user must reconfigure the mail application. Ensure that the user has a mail application compatible with IMAP4, for example, Netscape Communicator, which is bundled with the operating system software.

You also need to provide the user with information about mail service in your facility, as specified in Section 7.5.3.

## 7.5.5 Administrative Tools

You can use the following tools to administer the IMAP server:

- `cyradm` — Command line utility used for configuring and managing users, folders, subfolders, and so on. See `cyradm(1)`.
- `deliver` — Utility used to deliver mail to an IMAP mailbox. See `deliver(8)`.
- `dohash` — Utility used to convert the IMAP configuration directories from the format for older versions of the Cyrus IMAP4 Revision 1 server to the new format for Version 1.6.1 or higher. Another utility, `undohash`, reverses the process. See `dohash(8)`.
- `imapquota` — Utility used to report and fix IMAP mail quota usage. See `imapquota(8)`.
- `mailauth` — Utility used to manage the secondary mail password database. See `mailauth(8)`.
- `mailusradm` — System administration GUI utility used to configure mail users. See `mailusradm(8)`.
- `reconstruct` — Utility used to rebuild IMAP mailboxes. See `reconstruct(8)` for further information.

The IMAP server software sends log messages to the `syslogd` daemon. The log information is stored in the `/var/adm/syslog.dated/date/mail.log` file. You can use this data to solve problems. The severity levels are as follows:

NOTICE                      Authentications, both successful and unsuccessful.

ERR                          I/O errors, including failure to update quota usage.  
The message includes the specific file and UNIX error.

WARNING                    Protection mechanism failures, client inactivity timeouts.

INFO                        Mailbox openings.

## 7.5.6 Directory Structure

The IMAP configuration and mail files are distributed across the file system as indicated in Figure 7–6.

Figure 7–6: IMAP Directory Structure

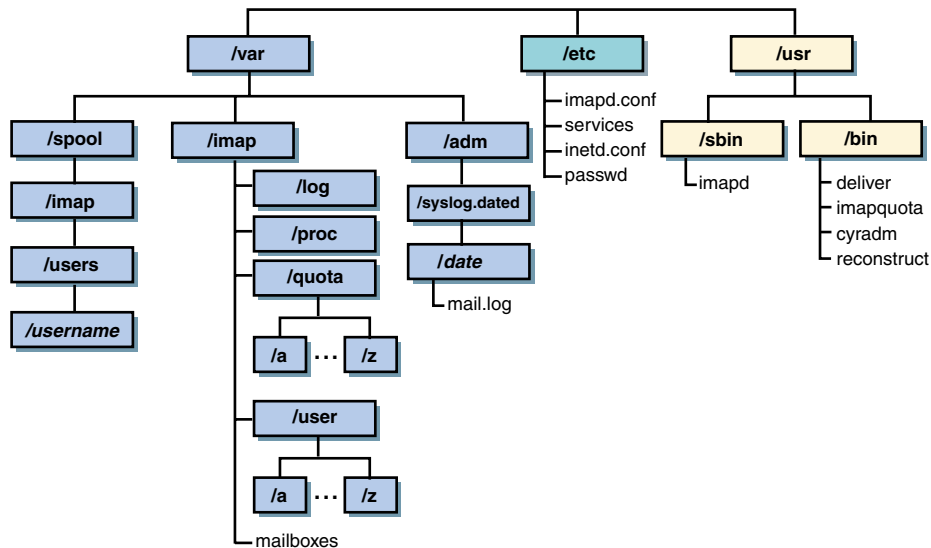

ZK-1541U-AI

All of the runtime configuration information is stored in the `/etc/imapd.conf` file. This file contains site configuration and policy options, such as:

- Location of the configuration directory
- Partition names and their corresponding directory roots
- Threshold for quota warning messages
- Whether or not to allow anonymous logins
- Whether or not to automatically create INBOX mailboxes for users

See `imapd.conf(4)` for further information.

The configuration directory specified in the `/etc/imapd.conf` file contains the items listed in Table 7–2.

**Table 7–2: Configuration Directory Contents**

| <b>File or Directory</b>            | <b>Purpose</b>  |
|-------------------------------------|---|
| <code>mailboxes</code> file         | <p>Contains a sorted list of each IMAP mailbox on the server along with mailboxes quota root and access control list (ACL), described in Section 7.5.9 and Section 7.5.8, respectively. Because the ACL is security-critical information that cannot be reconstructed from information stored elsewhere, there is no utility to recover from a damaged <code>mailboxes</code> file.</p> <p>To protect the contents of the mailboxes, make frequent (even hourly) backups of the <code>mailboxes</code> file to some other part of the disk.</p> |
| <code>user/a...z</code> directories | <p>Contain user subscriptions. There is one file per user, each file containing a sorted list of the user's mailboxes.</p> <p>Each file name consists of the user's user name followed by a <code>.sub</code> file extension, and the files are sorted into the <code>a</code> through <code>z</code> directories by the first letter of the user name.</p> <p>There is no utility for recovering damaged subscription files. You can restore lost files from backups.</p>  |
| <code>proc</code> directory         | <p>Contains one file per active server process. The filename is the ASCII representation of the process id, and the file contains the following tab-separated fields:</p> <ul style="list-style-type: none"><li>• Host name of client</li><li>• Username, if logged in</li><li>• Selected mailbox, if mailbox selected</li></ul> <p>The <code>proc</code> subdirectory is normally purged when you reboot the server.</p>   |

**Table 7–2: Configuration Directory Contents (cont.)**

| File or Directory       | Purpose   |
|-------------------------|---|
| quota/a...z directories | <p>Contain quota specifications for restricted IMAP users. There can be multiple files for each user, each file containing the limit for a quota root, as described in Section 7.5.9.</p> <p>Each file name consists of the string <code>user</code> followed by one or more extensions, starting with the associated user name (for example, <code>user.hansen</code>). The files are sorted into the <code>a</code> through <code>z</code> directories by the first letter of each user name.</p> <p>The <code>imapquota</code> program, when invoked with the <code>-f</code> switch, recalculates each user's quota. To remove the restrictions on a user's quota, remove the user's quota file. Then run <code>imapquota -f</code> to make the quota files consistent again.</p> |
| log directory           | <p>Contains zero or more subdirectories, each named after a user. If a subdirectory exists for a user, the server keeps a telemetry log of protocol sessions authenticating as that user. The telemetry log is stored in the subdirectory with a filename that matches the server's process ID. Use this feature only for debugging purposes; the log files grow rapidly.</p>   |

The largest database in the IMAP server is a user's mailbox directory. By default, these mailbox directories are located in the `/var/spool/imap/users` directory. There is one directory for each user and the directory name is the user's user name. If you have a highly populated mailbox tree, you can optionally sort these mailbox directories into `/var/spool/imap/users/a...z` subdirectories by specifying the `hashimapspool` option in the `imapd.conf` file. See `imapd.conf(4)` and `dohash(8)` for more information.

Each user's directory contains the files listed in Table 7–3.

**Table 7–3: Mailbox Directory Contents**

| <b>File or Directory</b> | <b>Purpose</b>   |
|--------------------------|--|
| message files            | Contain one message each in RFC 822 format. Lines in the message are separated by a carriage return and line feed, not just a line feed. The file name of each message is the message's UID followed by a dot (.). |
| cyrus.header             | Contains a magic number and variable-length information about the mailbox itself.  |
| cyrus.index              | Contains fixed-length information about the mailbox itself and each message in the mailbox.  |
| cyrus.cache              | Contains variable-length information about each message in the mailbox.  |
| cyrus.seen               | Contains variable-length state information about each user who has permission to read the mailbox.   |

The `reconstruct` utility can be used to recover from corruption in mailbox directories. If the `reconstruct` utility finds existing header and index files, it attempts to preserve any data in them that is not derivable from the message files themselves, including the flag names, flag state, and internal date. The utility derives all other information from the message files.

You can recover from a damaged disk by restoring message files from a backup and then running the `reconstruct` utility to regenerate what it can of the other files. The `reconstruct` program does not adjust the quota usage recorded in any quota file. After running `reconstruct`, run `imapquota -f` to fix the quota root files.

## 7.5.7 Mailbox Namespace

The IMAP server presents mailboxes using the `netnews` namespace convention. Mailbox names have the following restrictions:

- Are case-sensitive
- Cannot start or end with a period (.) character
- Cannot contain two period (..) characters in a row
- Cannot contain non-ASCII characters, shell metacharacters, or a backslash (/) character

All personal mailboxes for a user begin with the `user.username.` string. For example, mailboxes belonging to a user named Hansen begin with the `user.hansen.` string. If Hansen has a mailbox for work-related e-mail, it might be called `user.hansen.work.`



In the user's mail application, the prefix `user.hansen.` normally appears as `INBOX.`. The mailbox `user.hansen.work` therefore appears as `INBOX.work`. However, if the access control list (ACL) of the mailbox permits other users to see that mailbox, it appears to them as `user.hansen.work`.

You can create or delete a user's mailbox by creating or deleting the user's `INBOX`. A user with an `INBOX` can create and subscribe to personal mailboxes. Users with dots in their user names are able to log in, but cannot have an `INBOX` or receive IMAP mail. When you delete a user's `INBOX`, all of the personal mailboxes associated with it are deleted as well.

With the exception of `INBOX`, all mailbox names are system-wide; they refer to the same mailbox regardless of the user. ACLs determine which users can access or see certain mailboxes.

In contexts that permit relative mailbox names, the mailbox namespace works as follows:

- Names that do not start with a period (`.`) are fully qualified.
- Names that start with a period (`.`) are relative to the current context.

You might need to use this convention if you use the `telnet` command to connect to an IMAP port for troubleshooting purposes or if you create an application that issues IMAP calls.

If you are working with folder names and the top of the hierarchy is named `user.hansen`, the name `.work.personnel.issues` resolves to `user.hansen.work.personnel.issues` and the name `work.personnel.issues` resolves to `work.personnel.issues`.

## 7.5.8 Access Control Lists

Access to each mailbox is controlled by each mailbox's access control list (ACL). ACLs provide a mechanism for specifying the users or groups of users who have permission to access the mailboxes.

An ACL is a list of zero or more entries. Each entry has an identifier and a set of rights. The identifier specifies the user or group of users to which the entry applies. The set of rights is one or more letters or digits, each letter or digit conferring a particular privilege. See `cyradm(1)` for further information.

Access rights are defined as follows:

### **lookup** (1)

The user can see that the mailbox exists.

**read** (r)

The user can read the mailbox. The user can select the mailbox, retrieve data, perform searches, and copy messages from the mailbox.

**seen** (s)

The per-user seen state is preserved. The server saves the `Seen` and `Recent` flags for the user.

**write** (w)

The user can modify flags and keywords other than `Seen` and `Deleted` (which are controlled by other sets of rights).

**insert** (i)

The user can insert new messages into the mailbox.

**post** (p)

The user can send mail to the submission address for the mailbox. This right differs from the `i` right in that the delivery system inserts trace information into submitted messages.

**create** (c)

The user can create new sub-mailboxes of the mailbox.

**delete** (d)

The user can store the `Deleted` flag, perform expunges, and delete.

**administer** (a)

The user can change the ACL on the mailbox.

You can combine access rights in different ways. For example:

**lrs**

The user can read the mailbox.

**lrsp**

The user can read the mailbox and can post to it through the delivery system. Most delivery systems do not provide authentication, so the `post` right usually has meaning only for the anonymous user.

**lr**

The user can see the mailbox and can read it, but the server does not preserve the `Seen` and `Recent` flags. This set of rights is useful primarily for anonymous IMAP.

**rs**

The user can read the mailbox and the server preserves the `Seen` and `Recent` flags, but the mailbox is not visible to the user through the various mailbox listing commands. The user must know the name of the mailbox to be able to access it.

**lrsip**

The user can read and append to the mailbox either through IMAP or through the delivery system.

Any identifier may be prefixed with a dash (-) character. The associated rights are then removed from that identifier. These are referred to as negative rights.

To calculate the set of rights granted to a user, the server first calculates the union of all rights granted to the user and to all groups of which the user is a member. The server then calculates and removes the union of all negative rights granted to the user and to all groups of which the user is a member. For example, in the following ACL, the user named Fred is granted the rights `lrswip` and the user anonymous is granted the rights `lrp`:

```
anyone      lrsp
fred        lwi
-anonymous  s
```

Regardless of the ACL on a mailbox, users who are listed in the `admins` configuration option of the `/etc/imapd.conf` file implicitly have the lookup and administer rights on all mailboxes. Users also implicitly have the lookup and administer rights on the `INBOX` and all of their personal mailboxes.

When a mailbox is created, its ACL starts with a copy of the ACL of its closest parent mailbox. When a user is created, the ACL on the user's `INBOX` starts with a single entry granting all rights to the user. When a nonuser mailbox is created and does not have a parent, its ACL is initialized to the value of the `defaultacl` option in the `/etc/imapd.conf` file.

## 7.5.9 Quotas

You can use quotas to limit the system resources available to a user. The IMAP server supports quotas on storage.

A quota on storage is defined as the number of kilobytes of disk space that a user's messages are permitted to consume. Each copy of a message is counted independently, even when the server can conserve disk space by making hard links to message files. The additional disk space overhead used by mailbox index and cache files is not charged against a quota.

You can assign one quota on the overall space permitted for a user's mailboxes or you can assign different quotas on selected branches of a user's mailbox hierarchy. In either case, you apply the quota to the root of the mailbox hierarchy that you want to limit. The quota root encompasses any number of mailboxes in that hierarchy. Quotas on a quota root apply to the sum of the usage by all mailboxes at that level and below that level that is not part of a quota root on lower level, hence, each mailbox is limited by at most one quota root.

Figure 7-7 shows an example of quota roots for a user named Hansen.

**Figure 7-7: Quota Roots**

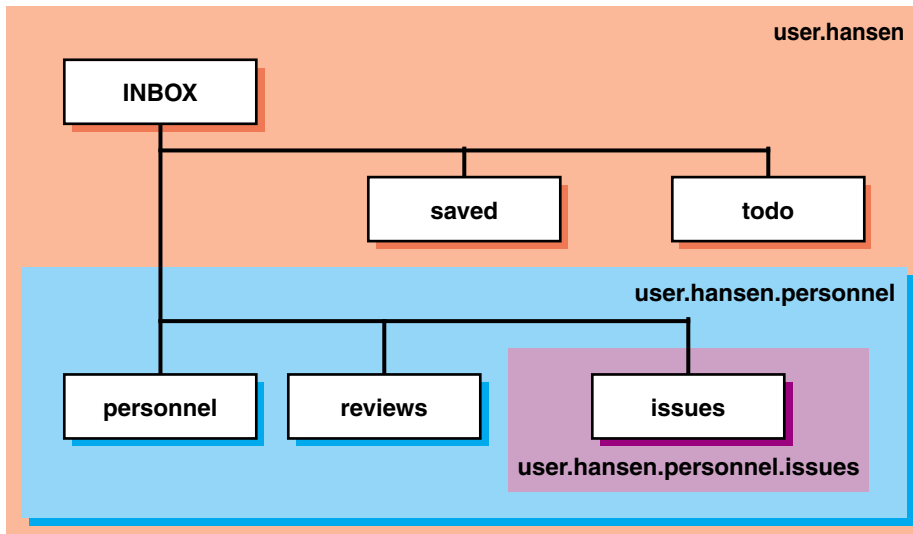

ZK-1578U-AI

In Figure 7-7, the user Hansen has the following mail folders:

```
user.hansen (INBOX)
user.hansen.personnel
user.hansen.personnel.reviews
user.hansen.personnel.issues
user.hansen.saved
user.hansen.todo
```

The following quota roots in the `quota/h` directory restrict Hansen's disk usage:

```
user.hansen
user.hansen.personnel
user.hansen.personnel.issues
```

The quota root `user.hansen` applies to the `INBOX`, `saved`, and `todo` mail folders. The quota root `user.hansen.personnel` applies to the `personnel` and `reviews` mail folders. The quota root `user.hansen.personnel.issues` applies only to the `issues` mail folder. If the `user.hansen.personnel` and `user.hansen.personnel.issues` quota roots did not exist, the restrictions specified for the `user.hansen` root would apply to all mail folders in the `user.hansen` hierarchy (those mail folders with the `user.hansen` prefix).

You can create quota roots by using the `setquota` command in the `cyradm` utility; however, you cannot delete quota roots with this utility. To remove a quota root, you must remove the associated quota file.

For a message to be inserted into a mailbox, the mailbox must have sufficient storage so that inserting the message will not exceed the quota root. This is always true of manual transfers from one folder to another, but mail delivery is a special exception. If the limit is not exceeded when delivery starts, then the message is delivered regardless of its size. If delivery of the new message exceeds the folder's quota, the `imapd` daemon informs the user and permits him or her to correct the problem. If mail delivery were not permitted in this case, the user would not know that mail cannot be delivered.

When the quota root is exceeded, mail delivery fails with a temporary error. The system attempts delivery for a few days, providing the user time to notice and correct the problem.

When a user selects a mail folder that is near or exceeds the quota, the server issues an alert to notify the user. You can use the `quotawarn` configuration option to set the threshold of usage at which the server issues quota warnings. The server issues warnings only when the user has rights to the folder because only users with rights can correct the problem.

## 7.5.10 Partitions

You can use partitions to store mailboxes in different parts of your file system. Hierarchies of mailboxes can be spread across multiple disks. You must use the `cyradm` utility to specify these alternate partitions; you cannot specify them from an IMAP mail application.

When creating a new mailbox, specify the name of the partition for the mailbox as an argument to the `createmailbox` command in the `cyradm`

utility. If the partition is not specified, the mailbox inherits the partition of its parent mailbox. If the mailbox has no parent, it defaults to the partition specified in the `defaultpartition` configuration option.

You can also change the partition of an existing mailbox by using the `renamemailbox` command in the `cyradm` utility. See `cyradm(8)` for more information.

Note that quota roots are independent of partitions. A single quota root can apply to a mailbox hierarchy that spans multiple partitions.

## 7.6 Managing Mail

This section describes how to perform the following mail tasks:

- Monitor the mail queue
- Archive the mail queue
- Administer and Distribute Alias Information
- Display mail statistics

### 7.6.1 Monitoring the Mail Queue

Monitoring the mail queue enables you to determine the status of several types of networking operations, including jobs that have been queued on a local system for transfer to a remote system. General users and system administrators can monitor the mail queue.

To display the contents of the mail queue, use the `mailq` command. This command lists the number of requests and the queue ID, the message size, the date the message entered the queue, and the sender and recipient for each request. Alternatively, you can use the `sendmail -bp` command.

See `mailq(1)` for more information.

If a major host is off line for a period of time, the number of entries in the queue might be quite large, causing the performance of the mail environment to suffer. To remedy this, you must archive the queue. See Section 7.6.2 for information.

The following example shows two requests in the mail queue:

```
# mailq
      Mail Queue (2 requests)
--QID-- --Size-- -----Q-Time----- Sender/Recipient-----
AA04956   1442 Tue Aug 24 10:12 <blaise>
      (Deferred)
      <corcoran@host1.corp.com>
AA08618* (no control file)
```

## 7.6.2 Archiving the Mail Queue

When a major host is off line for a number of days, the mail queue might grow to be quite large. As a result, the `sendmail` utility spends a lot of time sorting the large queue, severely affecting the mail environment performance. Archiving the mail queue enables your mail environment to function normally while the major host is off line. To archive the mail queue, do the following:

1. Log in as root.
2. Change to the `/var/spool` directory by using the `cd` command.
3. Stop the `sendmail` utility by entering the following command:  

```
# /sbin/init.d/sendmail stop
```
4. Verify that the `sendmail` utility is not running by entering the following command:  

```
# ps -e | grep sendmail
```
5. Verify that no `sendmail` child processes are running by entering the following command:  

```
# ps -e | grep queue
```

If any processes in the list are related to `sendmail`, for example, they include message queue IDs, it is best to wait until these processes are finished before moving the queue; otherwise, you might corrupt the queue data.
6. Move the `mqueue` directory to the `old.mqueue` directory by using the `mv` command.
7. Make a new `mqueue` directory by using the `mkdir` command.
8. Change the directory's permission code to `775` by using the `chmod` command.
9. Restart the `sendmail` utility by using the following command:  

```
# /sbin/init.d/sendmail restart
```

After the major host returns on line, process the old mail queue by using the following command:

```
# /usr/sbin/sendmail -oQ/var/spool/old.mqueue -q
```

When the queue is empty, remove it by using the following command:

```
# rm -r /var/spool/old.mqueue
```

### 7.6.3 Administering and Distributing Alias Information

Depending on how you choose to administer and distribute alias information on standalone or server systems, there are three ways to provide alias information for use in the mail environment:

- `/var/adm/sendmail/aliases` file
- NIS aliases database
- Lightweight Directory Access Protocol (LDAP)

By default, the `/var/adm/sendmail/aliases` file permissions code is 644. This means that global users cannot change and write the changes to the file. While this creates a reasonably secure system, it leaves the maintenance of the list of global users up to the system administrator.

You can distribute responsibility for maintenance by doing the following:

1. Create a local alias file for a global maintainer in a directory. Both the file and the directory must be accessible by another maintainer.
2. Create an entry in the `/var/adm/sendmail/aliases` file that includes the additional alias file. The entry has the following form:  

```
alias_name:    :include:filename
```

The *filename* is the full path name and file name of the alias file.
3. Build a new version of the alias file by using the `newaliases` command.

See `aliases(4)` for more information.

Optionally, you can use NIS to administer and distribute alias information for use in the mail environment. To use the NIS aliases database, do the following:

1. Install and configure NIS, if this is not already done, by using the `nissetup` script.
2. Edit the `svc.conf` file by using the `svcsetup` script, and modify the `aliases` entry to include `yp` (NIS).
3. Edit the NIS aliases map to include the alias information you want.

See Chapter 3 for information on configuring NIS and Section 3.4.5 for information on updating an NIS map.

Lastly, you can also use LDAP to administer and distribute alias information for use in the mail environment. LDAP might be the best choice for maintaining alias information when your alias database is too large or you have many systems in the network sharing the same information.



To use LDAP for maintaining alias information, do the following:

1. Configure LDAP server and create the proper schema for your environment. You may configure LDAP service on the mail server or, preferably, on an independent system. See `sendmail.m4(8)` and your LDAP server documentation for more information.
2. Create two attributes in your schema: one for the user's mail address and another for the user's alias.
3. Manually edit the `hostname.m4` file in the `/var/adm/sendmail` directory and make the following changes:
  - a. Set `_LDAPMap` to `{T}` to enable lookups.
  - b. Set `_LDAPParam` to define the map and its argument list. See `sendmail.m4(8)` for details.
4. Switch to the `/var/adm/sendmail` directory and execute the following command:

```
# make -f Makefile.cf.hostname
```
5. Rename the `hostname.cf` file to `sendmail.cf`, as follows:

```
# mv hostname.cf sendmail.cf
```
6. Restart the `sendmail` daemon by issuing the following command:

```
# /sbin/init.d/sendmail restart
```

Note that you need to perform steps 3–6 each time you configure mail with the `mailsetup` or the `mailconfig` utilities.

## 7.6.4 Displaying Mail Statistics

You can display statistics about mail traffic on your system by using the `mailstats` command as follows:

```
# /usr/sbin/mailstats
```

At any time, you can initialize the statistics file by issuing the following commands:

```
# cp /dev/null /var/adm/sendmail/sendmail.st
# chmod 666 /dev/null /var/adm/sendmail/sendmail.st
```

## 7.7 Mail Utilities

The operating system includes the following mail utilities:

- The `mail`, `binmail` utility (the default) — Used by the `sendmail` utility to deliver mail locally. Because the `mail` utility has root `setuid` permission, it handles delivery of all mail to a user's local mailbox

located in the `/var/spool/mail` directory. See the *Command and Shell User's Guide* and `mail(1)`.

- The `mailx`, Mail utility — A combination of the Berkeley Software Distribution's (BSD) and UNIX System Laboratories, Inc.'s System V Release 4 (SVR4) mail utilities. The `mailx` utility depends on the `binmail` utility for delivery to a user's mailbox. It has more user features than the `binmail` utility. See the *Command and Shell User's Guide* and `mail(1)`.
- The `dtmail` utility — The default mail program in CDE. This utility uses `sendmail` as the transport and stores information in much the same way as the `mailx` utility. It also allows you to read POP3 mail, and offers support for MIME-encoded messages. See the *Common Desktop Environment: User's Guide* and `dtmail(1)`.
- The message handler utility `mh` — It and its associated commands are included in the optional RAND Corporation Mail Handler subset (OSFMH). The message handler is composed of several shell commands where each command handles a specific function. For example, the `inc` command reads new mail and the `comp` command creates a message. Like the `mailx` utility, `mh` depends on the `mail` utility for delivery to a user's mailbox. The `mh` utility provides a graphical interface with the `xmh` command. See `xmh(1X)` for more information.
- Netscape Messenger — Part of the Netscape Communicator product, which is bundled with the operating system software. Messenger allows you to read mail from POP3 and IMAP4 mail servers. It also enables you to create rich HTML e-mail with embedded images, send MIME-encoded attachments, encrypt and decrypt your messages for privacy, use filters to organize your incoming messages into folders, and look up e-mail addresses. For more information on the Netscape Communicator product, see `netscape(1)`.

For more information on `sendmail`, see `sendmail(8)`, `sendmail.cf(4)`, and `sendmail.m4(8)`.

---

## Simple Network Management Protocol

This chapter describes the Simple Network Management Protocol (SNMP) implementation on a Tru64 UNIX system.

The Simple Network Management Protocol (SNMP) is the de facto industry standard for managing Transmission Control Protocol/Internet Protocol (TCP/IP) networks. The protocol defines the role of a Network Management Station (NMS) and the SNMP Agent, allowing remote users on an NMS to monitor and manage TCP/IP network entities.

---

### Note

---

Tru64 UNIX does not implement the NMS software.

---

Tru64 UNIX provides the `snmpd` daemon as the SNMP agent. This daemon is started at boot time. For information on how to set up and configure the `snmpd` daemon, see `snmpd(8)`.

The operating system includes two SNMP subagents:

- `os_mibs` — Implements industry-standard management information base (MIB) support, including MIB II, the FDDI MIB, the Token Ring MIB, the Host Resources MIB, and an Ethernet-like Interfaces MIB. See `os_mibs(8)` for a list of the related RFCs and Appendix F for a description of the Host Resources MIB implementation.
- `cpq_mibs` — Implements MIBs that are specific to the Tru64 UNIX operating system. See `os_mibs(8)` for more information about these MIBs.

These subagents are started and stopped automatically in conjunction with the `snmpd` daemon. Together, they provide the SNMP data required by the Insight Manager daemon, `insightd`, for managing Tru64 UNIX systems via the web. For more information, see `insightd(8)` and `insight_manager(5)`.

See the *Network Programmer's Guide* for information on registering applications with the SNMP agent.



# 9

---

## Solving Network and Network Services Problems

This chapter contains a diagnostic map to help you solve problems that might occur when you use the network and network services software. Use this chapter together with the appropriate Compaq documentation to solve as many problems as possible at your level.

Section 9.1 and Section 9.2 provide information about how to use the diagnostic map and where in the map to start for certain problems. The sections that follow contain portions of the diagnostic map. They describe how to solve problems on the following systems:

- DNS/BIND Servers (Section 9.3)
- DNS/BIND Clients (Section 9.4)
- NIS Servers (Section 9.5)
- NIS Clients (Section 9.6)
- NFS Servers (Section 9.7)
- NFS Clients (Section 9.8)
- Systems running UUCP (Section 9.9)
- Systems running NTP (Section 9.10)
- Systems running sendmail (Section 9.11)
- Systems running POP and IMAP mail (Section 9.12)

### 9.1 Using the Diagnostic Map

Network and network service problems can occur for a number of reasons. The diagnostic map in this chapter and a similar diagnostic map in the *Network Administration: Connections* manual help you to isolate the problem. The following figure explains how to use the diagnostic map:

The left-hand column asks questions about the status of specific events that occur as you use the system.

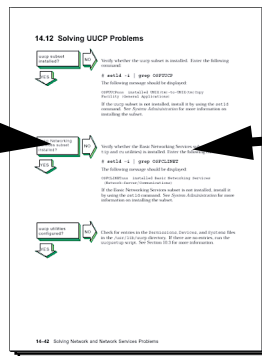

The right-hand column diagnoses negative responses to those questions.

After you isolate the problem, the map refers you to other chapters for instructions on using the various problem solving tools and utilities. The map also refers you to other manuals for more complete diagnostic information for particular devices and software products.

You could experience problems that are not documented in this manual when you use base system network and network services software with other layered products. See the documentation for the other products for additional information.

## 9.2 Getting Started

Before you start problem solving, ensure that the communications hardware is ready for use. Verify the following:

- The system's physical cable connections (the Ethernet connection and the transceiver connection) are properly installed. See the documentation for your system and communications hardware device.
- Event logging is enabled in order to monitor network events. See the *System Administration* manual for information on starting event logging and for descriptions of the event messages.

Also see the product release notes for up-to-date information on known problems.

Table 9–1 helps you identify a starting point in the diagnostic map.

**Table 9–1: Problem Solving Starting Points**

| If your problem is: | Start here: |
|---------------------|-------------|
| uucp command error  | Section 9.9 |

**Table 9–1: Problem Solving Starting Points (cont.)**

| <b>If your problem is:</b>                    | <b>Start here:</b>  |
|---|---|
| Network command error                         | Solving PPP Problems and Solving SLIP Problems sections in <i>Network Administration: Connections</i><br>Solving IPv4 Network Problems and Solving IPv6 Network Problems sections in <i>Network Administration: Connections</i> |
| Connecting to an ATM network                  | Solving ATM Problems section in <i>Network Administration: Connections</i><br>Solving IPv4 Network Problems and Solving IPv6 Network Problems sections in <i>Network Administration: Connections</i>                            |
| Obtaining an IP address using DHCP            | Solving DHCP Problems section in <i>Network Administration: Connections</i><br>Solving IPv4 Network Problems and Solving IPv6 Network Problems sections in <i>Network Administration: Connections</i>                           |
| Correcting system time when you are using NTP | Section 9.10  |
| Getting host name information                 | Section 9.4, if you are using DNS/BIND<br>Section 9.6, if you are using NIS   |
| Accessing files                               | Section 9.8, if you are using NFS<br>Solving IPv4 Network Problems and Solving IPv6 Network Problems sections in <i>Network Administration: Connections</i>   |
| Connecting to a host using LAT                | Solving LAT Problems section in <i>Network Administration: Connections</i> .  |
| Unknown errors                                | Solving IPv4 Network Problems section in <i>Network Administration: Connections</i>   |
| Unknown IPv6 errors                           | Solving IPv6 Network Problems section in <i>Network Administration: Connections</i>   |
| Sending or receiving mail                     | Section 9.11<br>Section 9.12, if you are using POP or IMAP mail   |

## 9.3 Solving DNS/BIND Server Problems

Additional Networking Services subset installed?

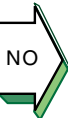

Verify that the Additional Networking Services subset is installed. Enter the following command:

```
# setld -i | grep OSFINET
```

If the subset is installed, the following message is displayed:

```
OSFINETnnn installed Additional Networking Services (Network-Server/Communications)
```

If the subset is not installed, install it by using the `setld` command. See the *Installation Guide* for more information on installing the subset.



DNS configured?



Use the `rcmgr` utility to display the value of the `BIND_SERVERTYPE` entry in the `/etc/rc.config.common` file:

```
# rcmgr get BIND_SERVERTYPE
```

If no type is specified, run the SysMan Menu utility to configure your DNS server. See Section 2.5 for more information.



DNS daemons started?

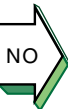

Verify that the BIND daemon (`named`) is running. Enter the following command:

```
# ps -e | grep named
```

If no `named` process is running, start the `named` daemon, using the following command:

```
# /sbin/init.d/named start
```



Authentication successful?

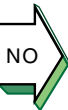

If you have enabled authentication, and secure dynamic updates or secure zone transfers are not successful, look for errors in the `daemon.log` file generated by the `syslogd` daemon. For secure dynamic updates, examine the log on the master server. For secure zone transfers, examine the log on the master server and the slave server. See Section 10.4 for more information about viewing `syslogd` message files.

If you see a `syntax error` near `'item'` message, look for syntax errors in your `named.conf` file and key file (possibly `named.keys`). Verify that there are no missing braces, quotes, or semicolons. If necessary, compare the contents of these files with those in Section 2.6.3.





If you see an unknown key `'key-name'` message or an Invalid TSIG secret `"key-string"` message, do the following:

1. Verify that you are using the correct key for the update or transfer.
2. Verify the spelling of the key name.
3. Verify the integrity of the key string. There must be no line feeds or spaces between the quotes that contain the key.
4. Verify that the algorithm specified for the key is `hmac-md5` and that the key was generated correctly. If necessary, generate a new key. See Section 2.6 for more information.

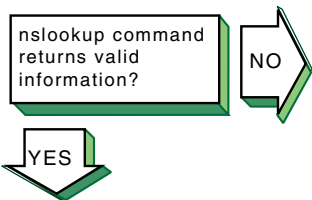

If the `nslookup` command does not return information for any host or the host specified in the client `nslookup` command, use the value of the `BIND_SERVERTYPE` entry you collected in a previous step to select a course of action from below:



Problem still exists?  
Report it to your service representative. See Chapter 12.

| If the type is: | Go to:  |
|-----------------|---|
| CLIENT          | Stop. This system is not a DNS/BIND server and cannot provide name resolution to clients. |
| MASTER          | Section 11.4  |
| SLAVE           | Section 11.4  |
| FORWARDER       | Section 11.5  |
| CACHING         | Section 11.9  |

## 9.4 Solving DNS/BIND Client Problems

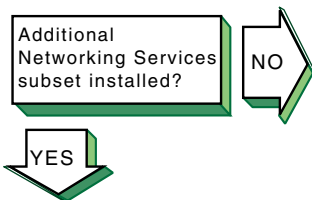

Verify that the Additional Networking Services subset is installed. Enter the following command:

```
# setld -i | grep OSFINET
```

If the subset is installed, the following message is displayed:

```
OSFINETnnn installed Additional Networking
Services (Network-Server/Communications)
```

If the subset is not installed, install it by using the `setld` command. See the *Installation Guide* for more information on installing the subset.

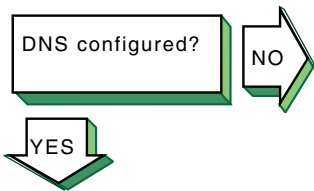

Use the `rcmgr` utility to display the value of the `BIND_SERVERTYPE` entry in the `/etc/rc.config.common` file:

```
# rcmgr get BIND_SERVERTYPE
```

If no type is specified, run the SysMan Menu utility to configure your DNS client. See Section 2.5 for more information.

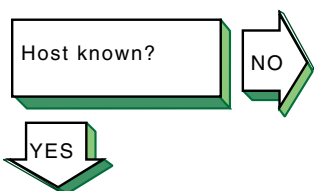

If you attempt to use one of the network commands (for example, `telnet`, `rlogin`, and `rsh` commands) and the remote host is not known, the following message is displayed:

```
unknown host
```

Complete the following steps:

1. Look in the `/etc/svc.conf` file to determine if DNS is being used for the `hosts` database lookup. If it is, go to step 2. If it is not, add it to the file by using the `/usr/sbin/svcsetup` script.
2. Retrieve information about the remote host with which you tried to communicate by using the `nslookup` command. Enter the following command:
 

```
# nslookup hostname
```

 If the command succeeds, the client is set up correctly; try the network command again. If the command fails, go to step 3.
3. View the `/etc/resolv.conf` file and retrieve the addresses for the `nameserver` entries.
4. Verify that the servers are reachable by using the `ping` command. If no servers are reachable, contact your network administrator. If any name server fails to respond to the `ping` command, delete the name server entry from the `resolv.conf` file.
5. Try the `nslookup` command again. If the command fails, see the solutions for solving DNS/BIND server problems in Section 9.3.



Problem still exists?  
Report it to your service representative. See Chapter 12.

## 9.5 Solving NIS Server Problems

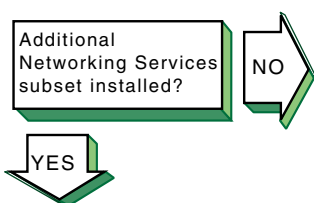

Verify that the Additional Networking Services subset is installed. Enter the following command:

```
# setld -i | grep OSFINET
```

If the subset is installed, the following message is displayed:

```
OSFINETnmm installed Additional Networking
Services (Network-Server/Communications)
```

If the subset is not installed, install it by using the `setld` command. See the *Installation Guide* for more information on installing the subset.

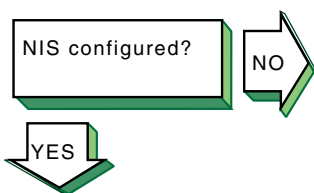

Use the `rcmgr` utility to display the value of the `NIS_CONF` entry in the `/etc/rc.config.common` file:

```
# rcmgr get NIS_CONF
```

If nothing is returned, run the SysMan Menu utility to configure your NIS server. See Section 3.3 for more information.

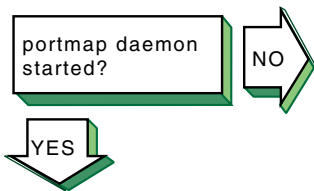

Verify that the `portmap` daemon is running. Enter the following command:

```
# ps -e | grep portmap
```

If you do not find the `portmap` daemon, stop and restart NIS, using the following commands:

```
# /sbin/init.d/nis stop  
# /sbin/init.d/nis start
```

If the `portmap` daemon does not start, reboot the server.

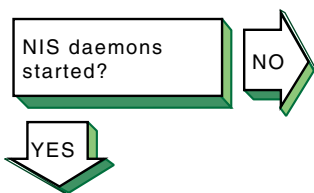

Verify that a `ypserv` process is running. Enter the following command:

```
# ps -e | grep yp
```

If no `ypserv` process is running, stop and start NIS, using the following commands:

```
# /sbin/init.d/nis stop  
# /sbin/init.d/nis start
```

If a `ypserv` process is running, execute a `ypwhich` command. Enter the following command:

```
# ypwhich
```

If nothing is returned, find the process ID (PID) of the `portmap` process and kill it. Enter the following commands:

```
# ps -e | grep portmap  
# kill -9 portmap_PID
```

---

#### Note

---

Because other network services use the `portmap` daemon, stopping it can affect network service. Therefore, notify your users of potential disruptions.

---

Stop and start NIS by using the following commands:

```
# /sbin/init.d/nis stop
# /sbin/init.d/nis start
```

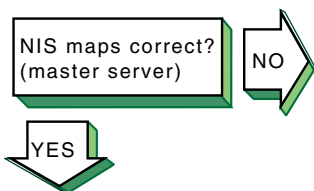

Verify that the information in the map is correct. Enter the following command:

```
# ypcat map_name
```

The *map\_name* variable is the name of the NIS map. If the information is incorrect, create a new map. Enter the following commands:

```
# cd /var/yp
# make map_name
```

The following message is displayed:

```
map_name updated
```

If the make command indicates that the database is not updated, complete the following steps:

1. Remove the *database\_name.time* file in the */var/yp* and */var/yp/domainname* directories.
2. Create a new map by using the make command. Enter the following commands:

```
# cd /var/yp
# make map_name
```

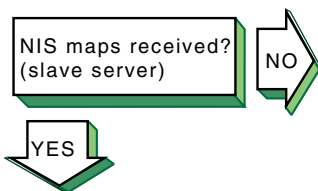

If you suspect that a slave server is not getting NIS map updates, complete the following steps on the slave server:

1. Verify that the NIS master server is running and reachable by using the ping command.
2. Create a *ypxfr* log file. Enter the following commands:

```
# cd /var/yp
# touch ypxfr.log
```

3. Run *ypxfr* interactively to get map updates. Enter the following command:

```
# ypxfr mapname
```

4. Examine the *ypxfr.log* file and resolve any problems. Remove the log file to turn logging off.
5. Verify the *ypxfr* entries in the */var/spool/cron/crontabs/root* file. Use either the *pg* command or the */usr/bin/crontab -l*



Problem still exists?  
Report it to your service  
representative. See  
Chapter 12.

command. The slave server entries are similar to the following:

```
# Network Information Service: SLAVE server entries
30 * * * * sh /var/yp/ypxfr_1perhour
31 1,13 * * * sh /var/yp/ypxfr_2perday
32 1 * * * sh /var/yp/ypxfr_2perday
```

6. Verify that the map has an entry in the corresponding ypxfr shell script.
7. Look in the syslogd daemon message files for any NIS messages. See Section 10.4 for more information.
8. Verify that the slave server is in the ypservers map for the domain.

## 9.6 Solving NIS Client Problems

Use the `rcmgr` utility to display the value of the `NIS_CONF` entry in the `/etc/rc.config.common` file:

```
# rcmgr get NIS_CONF
```

If nothing is returned, run the SysMan Menu utility to configure your NIS client. See Section 3.3 for more information.

Use the `/usr/sbin/svcsetup` script to verify that the `svc.conf` file contains entries for NIS. NIS entries are indicated by the letters “yp.”

For the `passwd` and `group` databases, the Security Integration Architecture (SIA) controls whether or not NIS is used. However, in order to use NIS, a plus sign followed by a colon (+:) must be on the last line in both databases.

Verify that the `portmap` daemon is running. Enter the following command:

```
# ps -e | grep portmap
```

If no `portmap` daemon is running, stop and restart NIS, using the following commands:

```
# /sbin/init.d/nis stop
# /sbin/init.d/nis start
```

If the `portmap` daemon does not start, reboot the client.

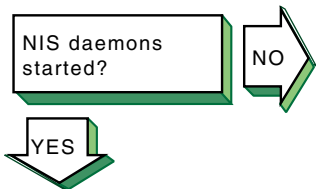

Verify that a `ypbind` process is running. Enter the following command:

```
# ps -e | grep yp
```

If no `ypbind` process is running, stop and start NIS, using the following commands:

```
# /sbin/init.d/nis stop  
# /sbin/init.d/nis start
```

If a `ypbind` process is running, enter the `ypwhich` command:

```
# ypwhich
```

If the `ypwhich` command does not return an answer, kill the `portmap` process. Enter the following command:

```
# kill -9 portmap_PID
```

Stop and start NIS, using the following commands:

```
# /sbin/init.d/nis stop  
# /sbin/init.d/nis start
```

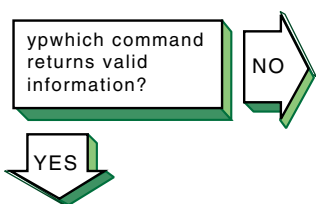

If the `ypwhich` command displays inconsistent information when invoked several times in succession, your client system is changing the server system to which it is bound. This can occur over time, especially if your system is on a busy network or if the NIS servers are busy. Once all clients get acceptable response time from the NIS servers, the system will stabilize.

If the `ypwhich` command reports that the domain is not bound, your system did not initially bind to a server system. Issue a `ypcat` command, then reissue the `ypwhich` command.

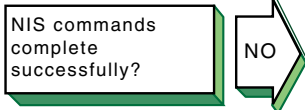

If an NIS command hangs, the following message is displayed on the console:

```
yp: server not responding for domain domainname.  
Still trying
```



The client cannot communicate with the server. Complete the following steps:



Problem still exists?  
Report it to your service representative. See Chapter 12.

1. Use the `rcmgr` command to verify that the domain name returned by the `domainname` command matches the value of the `NIS_DOMAIN` entry in the server's `/etc/rc.config.common` file:

```
# rcmgr get NIS_CONF
```

If the domain name does not match, or is not correct for your environment (note that the domain name is case-sensitive), reconfigure the client system by using the SysMan Menu utility. See Section 3.3 for more information.

2. Verify that at least one NIS server for your domain is running on your local subnetwork. If there is not, reconfigure the client by using the SysMan Menu utility, and choose to use the `-S` option to the `ypbind` command.
3. Determine if other clients on the subnetwork are having problems with any of the NIS commands.
4. Verify that `ypserv` daemon was started on the server by entering the following command:

```
# rpcinfo -p server_name
```

Also, verify that the `ypserv` daemon is currently running on the server by entering the following command:

```
# rpcinfo -t server_name ypserv 2
```

If the server fails either test, stop and restart NIS on the server as follows:

```
# /sbin/init.d/nis stop  
# /sbin/init.d/nis start
```

5. Look in the `syslogd` daemon message files for any NIS messages. See Section 10.4 for more information.
6. Verify that the server is running. See the solutions for solving NIS server problems in Section 9.5.

If the previous steps do not solve the problem, complete the following steps:

1. Stop and start NIS. Enter the following commands:

```
# /sbin/init.d/nis stop  
# /sbin/init.d/nis start
```

If this does not solve the problem, go to step 2.

2. Reboot the system.
3. Reconfigure NIS by running the SysMan Menu utility.

## 9.7 Solving NFS Server Problems

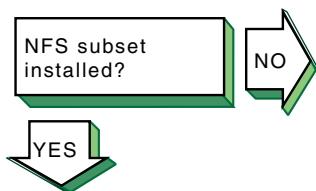

Verify that the NFS Utilities subset is installed. Enter the following command:

```
# setld -i | grep OSFNFS
```

If the subset is installed, the following message is displayed:

```
OSFNFSnnn installed NFS(tm) Utilities  
(Network-Server/Communications)
```

If the subset is not installed, install it by using the `setld` command. See the *Installation Guide* for more information on installing the subset.

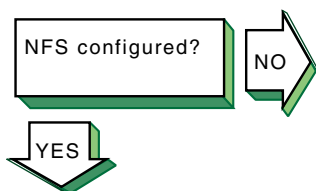

Use the `rcmgr` utility to display the value of the `NFSSERVING` entry in the `/etc/rc.config.common` file:

```
# rcmgr get NFSSERVING
```

If nothing is returned, run the SysMan Menu utility to configure your NFS server. See Section 4.3 for more information.

Verify that the network software has been configured. See the solution at *Network configured?* in the diagnostic map in *Network Administration: Connections*.

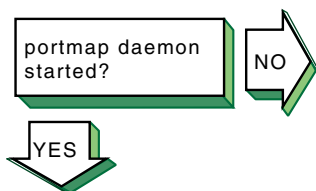

Verify that the `portmap` daemon is running. Enter the following command:

```
# ps -e | grep portmap
```

If the `portmap` daemon is not running, stop and restart NFS by using the following commands:

```
# /sbin/init.d/nfs stop  
# /sbin/init.d/nfs start
```

If the `portmap` daemon does not start, reboot the server.



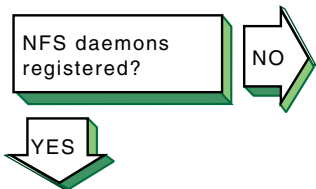

Verify that the NFS daemons are registered with the portmap daemon. Enter the following commands:

```
# rpcinfo -u server_name mount
# rpcinfo -u server_name nfs
```

If neither is registered, start NFS by using the following command:

```
# /sbin/init.d/nfs start
```

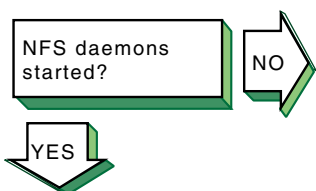

To verify that the NFS daemons are running, complete the following steps:

1. Verify that a `mountd` process is running. Enter the following command:

```
# ps -e | grep mountd
```

If a `mountd` process is running, go to step 2. If no `mountd` process is running, stop and start NFS by using the following commands:

```
# /sbin/init.d/nfs stop
# /sbin/init.d/nfs start
```

2. Verify that an `nfsd` process is running. Enter the following command:

```
# ps -e | grep nfsd
```

If no `nfsd` process is running, stop and start NFS by using the following commands:

```
# /sbin/init.d/nfs stop
# /sbin/init.d/nfs start
```

Alternatively, you can use the SysMan Menu utility to view the status of some NFS daemons. You can skip directly to the status dialog box by entering the following command:

```
# /usr/sbin/sysman nfs_daemon_status
```

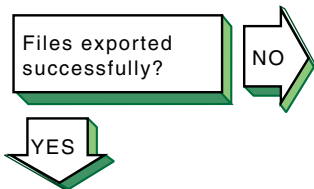

Problem still exists?  
Report it to your service  
representative. See  
Chapter 12.

To verify that the files are being exported, complete the following steps:

1. Verify that file is being exported. Enter the following command:
 

```
# showmount -e
```

 If the file is being exported, go to step 3.
2. If the file is not being exported, verify that the file has an entry in the `/etc/exports` file. If there is no entry in the `/etc/exports` file, edit the file and create an entry. Have the remote system mount the file.
3. If the file is being exported and the users cannot mount the file, use the `rcmgr` utility to display the value of the `NONROOTMOUNTS` entry in the `/etc/rc.config` file and determine if the users are allowed to mount the file:
 

```
# rcmgr get NONROOTMOUNTS
```

 If the `NONROOTMOUNTS` parameter is 0, only users running as root can mount files from this server. To allow users not running as root to mount the files, enter the following command:
 

```
# rcmgr set NONROOTMOUNTS 1
```
4. Verify that the `mountd` daemon is running with Internet address checking on. Enter the following command:
 

```
# ps -e | grep mountd
```

 If the `-i` option is displayed, the client's name and address must be in the `/etc/hosts` file, or in the DNS or NIS hosts database. Only known hosts can mount the file system. If the `-d` or `-s` option is displayed, the client system must be in the same DNS domain or subdomain, respectively, as the server.
5. If the `mountd` daemon is returning stale file handles for exported files, send a hangup signal (SIGHUP) to the `mountd` daemon to force it to reread the `/etc/exports` file. Enter the following commands:
 

```
# ps -e | grep mountd
# kill -1 mountd_pid
```

## 9.8 Solving NFS Client Problems

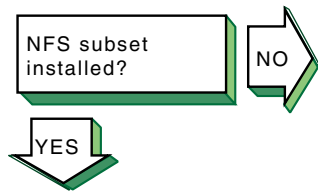

Verify that the NFS Utilities subset is installed. Enter the following command:

```
# setld -i | grep OSFNFS
```

If the subset is installed, the following message is displayed:

```
OSFNFSnnn installed NFS(tm) Utilities  
(Network-Server/Communications)
```

If the subset is not installed, install it by using the `setld` command. See the *Installation Guide* for more information on installing the subset.

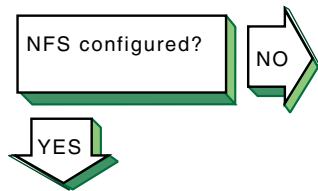

Use the `rcmgr` utility to display the value of the `NFS_CONFIGURED` entry in the `/etc/rc.config.common` file:

```
# rcmgr get NFS_CONFIGURED
```

If nothing is returned, run the SysMan Menu utility to configure your NFS client. See Section 4.3 for more information.

Verify that the network software has been configured. See the solution at *Network configured?* in the diagnostic map in *Network Administration: Connections*.

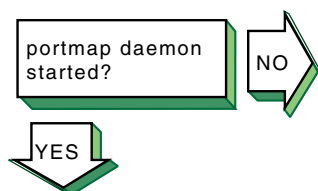

Verify that the `portmap` daemon is running. Enter the following command:

```
# ps -e | grep portmap
```

If the `portmap` daemon is not running, stop and restart NFS by using the following commands:

```
# /sbin/init.d/nfs stop  
# /sbin/init.d/nfs start
```

If the `portmap` daemon does not start, reboot the client.

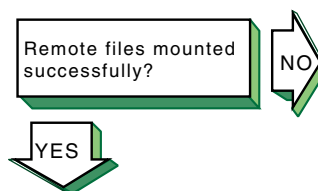

If the client cannot mount a remote file system or directory, complete the following steps:

1. If an error message is displayed on the user's terminal, see Appendix C for the error message and a description.
2. Verify that the remote NFS server is on your local network and in your `hosts` database.
3. Verify that the server daemons on the remote system are running. Enter the following command:

```
# rpcinfo -p server_name
```

4. Verify that the server is exporting the files you want to mount. Enter the following command:
 

```
# showmount -e server_name
```
5. See the solutions for solving NFS server problems in Section 9.7. If the server is running and you still have problems, verify the Ethernet connections and the Internet connections between the client system and the remote server.
6. Determine if other clients on the network are having problems with the remote server.
7. Verify that the mount command line or the entry in the `/etc/fstab` file is correct, and verify the following:
  - a. The host name matches the name of the remote NFS server.
  - b. The mount point exists on your system.
8. If you get an authentication error, verify the following:
  - a. If you are not a superuser, the server allows nonroot mounts.
  - b. Your host name is in the server's `hosts` database.
  - c. If your system is not in the same domain as the server, the server performs domain checking. See `mountd(8)` for more information on server options.

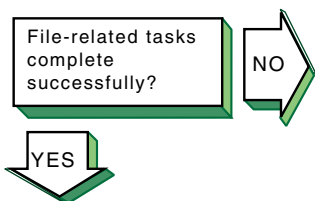

If application programs that perform file-related tasks do not complete their tasks or take a long time to do so, complete the following steps:

1. If an error message is displayed on the user's terminal, see Appendix C for the error message and a description.
2. Verify that the server is running. See the solutions for solving NFS server problems in Section 9.7. If the server is running, verify that the `nfsd` daemon is accumulating CPU time. If it is not, kill it and restart it. If this does not solve the problem, reboot the server. If the remote file systems or directories are mounted with the `hard` option, the program continues when the server is running once again.
3. Determine if other clients on the network are having problems with the remote server. If they are not, verify that the Ethernet connections and the internet connections between the client system and the remote server are working properly.
4. Determine if any `nfsiod` daemons are running. Enter the following command:



Problem still exists?  
Report it to your service representative. See Chapter 12.

```
# ps -e | grep nfsiod
```

If no `nfsiod` daemons are running, start some. Enter the following command:

```
# /usr/sbin/nfsiod 7
```

Although the `nfsiod` daemons are not necessary for a client, they perform read-ahead and write-behind functions, which might make I/O faster.

5. If file access requests succeed but file locking requests hang indefinitely, verify that the local `rpc.statd` and `rpc.lockd` daemons are running. Enter the following commands:

```
# ps -e | grep rpc.statd
# ps -e | grep rpc.lockd
```

If they are not running, start them. Enter the following commands:

```
# /usr/sbin/rpc.statd
# /usr/sbin/rpc.lockd
```

Also, verify that the local `rpc.statd` and `rpc.lockd` daemons are running on the server. Enter the following commands:

```
# rpcinfo -p server_name | grep status
# rpcinfo -p server_name | grep lockmgr
```

If they are not running, contact the server's system administrator.

Alternatively, you can use the SysMan Menu utility to view the status of some NFS daemons. You can skip directly to the status dialog box by entering the following command:

```
# /usr/sbin/sysman nfs_daemon_status
```

## 9.9 Solving UUCP Problems

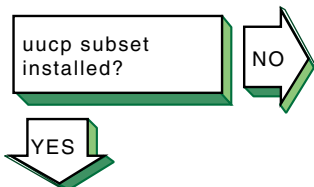

Verify that the UNIX-to-UNIX Copy Facility subset is installed. Enter the following command:

```
# setld -i | grep OSFUUCP
```

If the subset is installed, the following message is displayed:

```
OSFUUCPnnn installed UNIX(tm)-to-UNIX(tm) Copy
Facility (General Applications)
```

If the subset is not installed, install it by using the `setld` command. See the *Installation Guide* for more information on installing the subset.

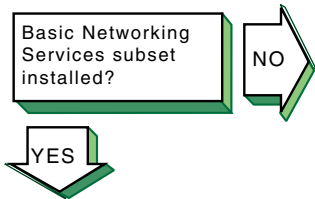

Verify that the Basic Networking Services subset (containing the `tip` and `cu` utilities) is installed. Enter the following command:

```
# setld -i | grep OSFCLINET
```

If the subset is installed, the following message is displayed:

```
OSFCLINETnnn installed Basic Networking Services  
(Network-Server/Communications)
```

If the subset is not installed, install it by using the `setld` command. See the *Installation Guide* for more information on installing the subset.

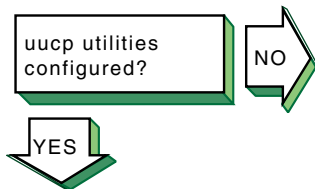

Look for entries in the Permissions, Devices, and Systems files in the `/usr/lib/uucp` directory. If there are no entries, run the `uucpsetup` script. See Section 5.3 for more information.

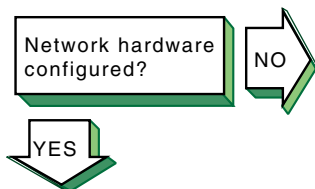

Configure the network hardware as follows:

- Direct connections to remote host — Use a null modem or modem eliminator cable to connect your system to the remote host.
- Phone line connection to remote host — Use a cable to connect your system to a modem and another cable to connect your modem to a phone line. The modem you use must be compatible with the modem at the remote host. Make sure the modem is configured as follows:
  - Forced data set ready (DSR) is disabled.
  - Full or verbose status messages are enabled.
  - Character echo is disabled.
  - Use 8-bit characters with no parity.
  - XON/XOFF flow control is disabled.
- TCP/IP connection to remote host — Use a cable to connect your system to the network. Then, run the Network Configuration application to configure the network. See *Network Administration: Connections* for more information on setting up the network.

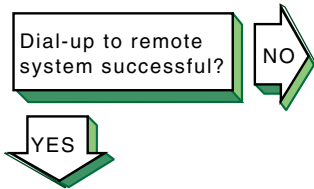

If you cannot dial up the remote system, verify the following:

1. Make sure that the setup parameters (such as speed, parity, modem control, flow control, and other terminal characteristics) on the local and remote ends are properly defined for your modem type.
2. Dial the number to the remote node. If you do not get an "Attached" message or a login prompt, plug a telephone handset into the local telephone line to verify that there is a dial tone. If you do not hear a dial tone, call your local carrier to fix this problem. If you get no message, verify that the cabling between the local system and the modem is properly installed and undamaged.
3. If you get a dial tone, check that your modem is operational and perform diagnostic tests on your modem. See the modem manual for more information.
4. From another handset, dial the local telephone line. If the local telephone rings and you can carry on a conversation, the telephone line on the local end is good. If you cannot pass voice traffic, or if there is no ring, call your local carrier to fix this problem.
5. Repeat steps 2 and 3 on the remote node to resolve problems with the remote end.
6. If the telephone line is operational, verify that the remote modem is set up to automatically answer incoming calls when the system raises the data terminal ready (DTR) signal. The system raises the DTR signal by issuing a `uucgetty` or `getty` command on the port.

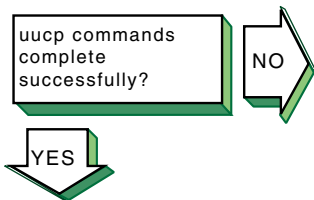

Run the `uucp` tests to test the connection to the remote system. See Section 10.1 and Section 10.2.

If you can establish a connection, but your file transfer eventually times out and exits, attempt to set the type of flow control that the `uucico` daemon uses, as described in Section 5.3.5 and the `uucico(8)` reference page.

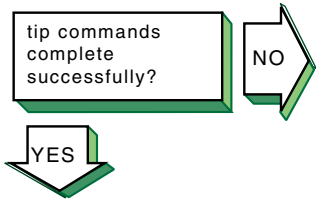

Problem still exists?  
Report it to your service representative. See Chapter 12.

If the `tip` command does not execute successfully, complete the following steps:

1. Verify that the system name, connection speed, and phone number are in the `/etc/remote` file or that the system name and connection speed are in the `/etc/remote` file and the phone number is in the `/etc/phones` file. See `remote(4)` and `phones(4)` for more information.
2. Examine the `at` entry in the `/etc/remote` file. If the entry is correct, create an entry for the modem in the `/etc/acucap` file. See `acucap(4)` for more information.
3. Verify that the remote system is configured to answer incoming calls.

## 9.10 Solving NTP Problems

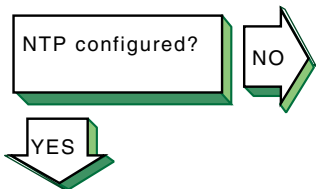

Use the `rcmgr` utility to display the value of the `XNTPD_CONF` entry in the `/etc/rc.config` file:

```
# rcmgr get XNTPD_CONF
```

If nothing is returned, run the SysMan Menu utility to configure NTP. See Section 6.3 for more information.

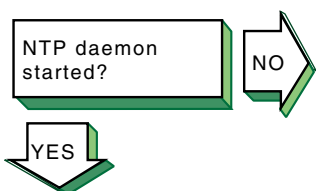

Verify that an `xntpd` process is running. Enter the following command:

```
# ps -e | grep xntpd
```

Alternatively, you can use the SysMan Menu utility to view the status of the `xntpd` daemon. You can skip directly to the status dialog box by entering the following command:

```
# /usr/sbin/sysman ntp_status
```

If no `xntpd` process is running, start NTP by using the following command:

```
# /sbin/init.d/xntpd start
```

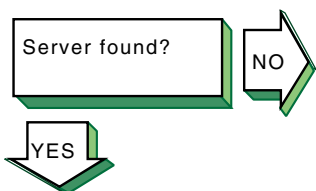

If the `ntpq` or `xntpd` command cannot find the server host, the following message is displayed:

```
***Can't find host hostname
```

The `hostname` is not in the `/etc/hosts` file, the DNS `hosts` database, or the NIS `hosts` database. Edit the appropriate file or database and add an entry for the server host.



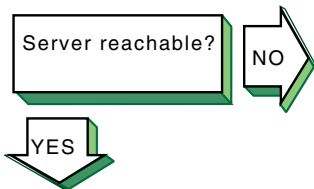

If you run one of the monitor programs and in the output from the `peers` command the reach column contains zeros (0s), complete the following steps:

1. Contact the system administrator of the server and verify which NTP daemon the server is running. The entry for the server in the `/etc/ntp.conf` file must contain the phrase `version x` after the server name, as follows:
 

```
server host1 version x
```
2. Look in the `/etc/hosts` file and verify that there is an entry for each NTP server specified in the `/etc/ntp.conf` file. If you are using either DNS or NIS for host information, verify that the `hosts` database has an entry for each NTP server.

If the `xntpd hostname` command does not display any information, verify that the `hostname` server is running NTP.

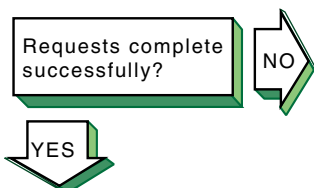

If the `ntpq` or `xntpd` request times out, the following message is displayed:

```
hostname: timed out, nothing received
***Request timed out
```

Complete the following steps:

1. The `hostname` is not running the `xntpd` daemon. Contact the system administrator for that system.
2. The network connection has gone down. See the solutions for Host Reachable? in the diagnostic map in *Network Administration: Connections*.



Problem still exists?  
Report it to your service representative. See Chapter 12.

If you still cannot solve the problem, complete the following steps:

1. Examine the `/etc/rc.config` file to make sure it contains entries similar to the following:

```
XNTPD_CONF="YES"
export XNTPD_CONF
XNTP_SERV1=server1
export XNTP_SERV1
XNTP_SERV2=server2
export XNTP_SERV2
XNTP_SERV3=server3
export XNTP_SERV3
XNTPD_OPTS="-g"
export XNTPD_OPTS
```

If this entry does not exist or is incorrect, run the SysMan Menu utility to configure NTP. See Section 6.3 for more information.

2. Examine the `/etc/ntp.conf` file and make sure the information in it is accurate. It must contain entries for hosts running NTP with which you want to synchronize system time. Make sure the correct version number is specified for each server and peer. Use the SysMan Menu utility to correct any entries. See Section 6.3 for information.
3. Look in the `/var/adm/syslog.dated/current/daemon.log` file for information about NTP problems on the system. See Section 10.4 for more information.

## 9.11 Solving sendmail Problems

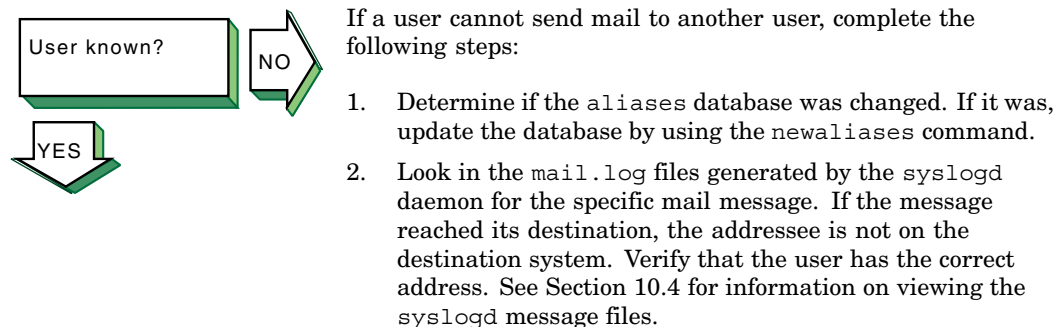
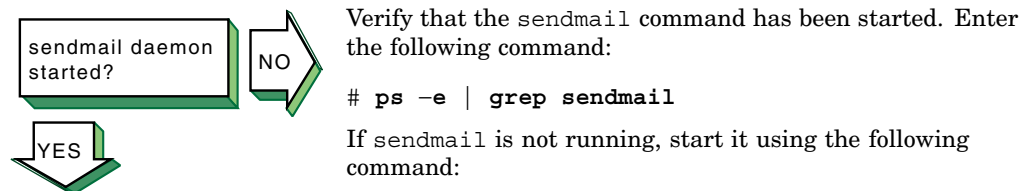
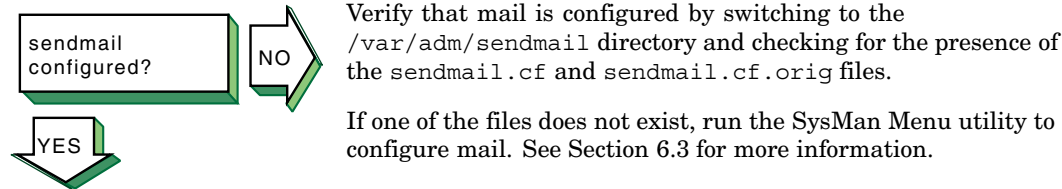

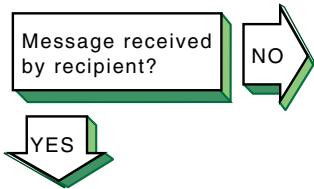

If you sent a mail message and the recipient did not receive it, complete the following steps:

1. Verify that the address is correct.
2. Verify that the remote node is reachable by using the `ping` command.
3. Look in the `mail.log` files generated by the `syslogd` daemon for the sender's user name. See Section 10.4 for information on viewing the `syslogd` message files. If you find an entry, write down the message ID. If no entry is found, send the message again.
4. Using the message ID, search through the `mail.log` files for the "from" and "to" entries. If you find a "from" entry but no "to" entry, either `sendmail` did not receive the message or the message was corrupted. Look in the `/var/spool/mqueue` directory for files containing the message ID by entering the following command:

```
# ls -l /var/spool/mqueue/*message_ID
```

Possible outcomes include:

- The `qf*message_ID` control file is present but the `(df*message_ID)` data file is not. The message was lost.
- A "from" entry and a "to" entry exist, and the status is deferred. The message is in the queue.
- There is no corresponding sent entry. Use the `mailq` command to report the reason for the deferral.
- A "from" entry and a "to" entry exist, the status is sent, and the message was delivered. If a local delivery, the message reached the destination. If a remote delivery, have the system administrator on the remote host search for the message.

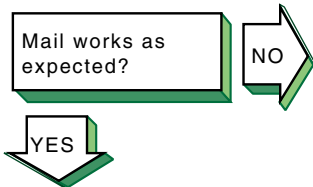

If sendmail is not working correctly, complete the following steps:

1. Look in the rejected message for an error message.
2. Look for error messages in the `mail.log` files generated by the `syslogd` daemon. See Section 10.4 for information on viewing the `syslogd` message files.

See Appendix E for a list of `sendmail` error messages.



Problem still exists?  
Report it to your service representative. See Chapter 12.

## 9.12 Solving POP and IMAP Problems

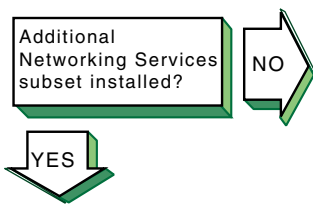

Verify that the Additional Networking Services subset is installed on the server. Enter the following command:

```
# setld -i | grep OSFINET
```

If the subset is installed, the following message is displayed:

```
OSFINETnnn installed Additional Networking
Services (Network-Server/Communications)
```

If the subset is not installed, install it by using the `setld` command. See the *Installation Guide* for more information on installing the subset.

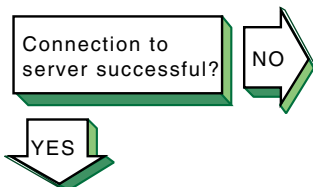

If the user cannot connect to the Post Office Protocol (POP) or Internet Message Access Protocol (IMAP) server:

1. Verify that the user is connecting to the correct server.
2. Verify that the server is reachable by using the `ping` command.
3. Verify the POP or IMAP entries in the `/etc/passwd`, `/etc/services`, and `/etc/inetd.conf` files on the server, as described in Section 7.4.1 and Section 7.5.1. If necessary, restart network services to effect the changes.

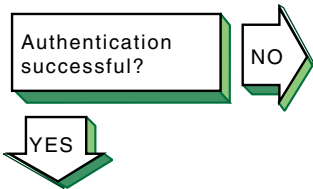

Verify that the user has specified a valid user name and password. Use the `mailusradm` utility to verify the existence of the POP or IMAP account on the server or to change the password, if necessary.

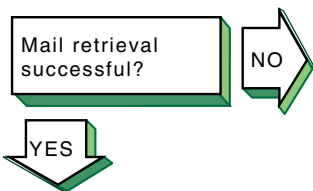

If a user cannot retrieve mail from the POP or IMAP server:

1. Verify that the user has a POP3 or IMAP4-compatible mail program.
2. For POP, look in the `/usr/spool/mail` directory for a lock file named after the user. If one exists, delete the file to remove the lock.
3. For IMAP, verify that the user has proper ACLs for the IMAP mail folder by using the `cyradm` command. See Section 7.5.8 and `cyradm(8)`.
4. Look in the `mail.log` files generated by the `syslogd` daemon for error messages related to POP or IMAP. See Section 10.4 for information on viewing the `syslogd` message files.
5. Create a directory with the user's account name in the `configdirectory/log` directory (usually, the log directory is `/var/imap/log`, see the `/etc/imapd.conf` file for the location of the `configdirectory` on your system). When the user attempts to access the server, examine the log of the session to see where the error occurs.

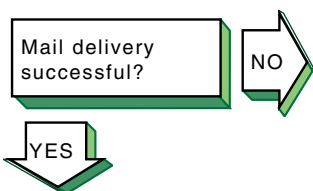

If the user is not receiving new mail:

1. Look in the `mail.log` files generated by the `syslogd` daemon for errors. See Section 10.4 for information on viewing the `syslogd` message files.
2. For IMAP, look at the user and quota configuration directories to verify that subdirectories a through z exist (see Section 7.5.2), that the subdirectories contain the proper files for the given user (see Section 7.5.6), and that all directories and files under `/var/imap` and `/var/spool/imap` are owned by the `imap` user.



Problem still exists?  
Report it to your service representative. See Chapter 12.

If the user cannot send mail:

1. Verify that the user is connecting to the correct SMTP server.
2. Verify that the SMTP server is reachable by using the `ping` command.

3. See Section 9.11 on solving `sendmail` problems.

# 10

---

## Using the Problem Solving Tools

To help you resolve problems with network services, the operating system provides problem solving tools you can use to complete the following tasks:

- Test a UUCP remote connection (Section 10.1)
- Monitor a UUCP file transfer (Section 10.2)
- Display the error log file (Section 10.3)
- Display the `syslogd` daemon message files (Section 10.4)

The following sections contain information about using the tools associated with these tasks. For information about additional tools you can use to diagnose network connections and network hardware, see *Network Administration: Connections*.

### 10.1 Testing a UUCP Remote Connection

Testing a UUCP remote connection can help you diagnose certain UUCP problems; for example, to determine why there is a backlog of transfer requests in the queue.

To test a remote connection, do the following:

1. Log in as root.
2. Change to the `/usr/lib/uucp` directory by using the `cd` command.
3. Test the remote connection by using the `uutry` command, using the following syntax:

**`uutry system_name`**

The `system_name` variable names the remote system to contact.

4. Examine the debugging output; the last line contains the status of the transaction. If your local system establishes a connection to the remote system, the debugging output contains a good deal of information. You can press `Ctrl/c` to stop the `uutry` shell script.

The `uutry` command has the following characteristics:

- It is a shell script stored in the `/usr/lib/uucp` directory.
- It contacts a remote system with debugging turned on. If you are using the UUCP scheduler, `uusched`, to start the `uucico` daemon automatically at

specified intervals, the `uutry` command overrides the retry time interval specified in the `/usr/spool/uucp/.Status/system_name` file.

If you use the `uutry` command frequently, you can put the pathname to the command in the `PATH` entry in your `.profile` file.

- It directs debugging information to a file named `/tmp/system_name`, where `system_name` is the name of the local system. The `uutry` command then executes a `tail -f` command to display the file's contents.

If your local system cannot contact the remote system, do the following:

1. Validate the physical connections between the local and remote systems. At both systems, confirm that the computer is turned on, that all the cables are properly connected, that the ports are enabled, and the modems (if being used) are working. If the remote system is not at your physical location, contact the administrator of the remote system.
2. Verify all configuration files on both systems. Verify that all entries in the `Devices`, `Systems`, and `Permissions` files are correct. If you are using a modem, verify all entries in the `Dialers` and `Dialcodes` files.

If you are using a TCP/IP connection, verify that the configuration files contain the correct TCP entries. Verify that the `inetd` daemon can start the `uucpd` daemon. Edit the `/etc/inetd.conf` file and delete the comment character (`#`) from the beginning of the line containing the `uucp` entry. Restart the `inetd` daemon by using the following command:

```
# /sbin/init.d/inetd start
```

Always save the debugging output produced by the `uutry` command until you are certain that the problem is resolved.

The following example shows a successful test of a remote connection to system `host6`:

```
# /usr/lib/uucp/uutry host6
:
Conversation Complete: Status SUCCEEDED
```

The following example shows an unsuccessful test of a remote connection to system `host6`:

```
# /usr/lib/uucp/uutry host6
:
mchFind called (host6)
conn (host6)
getto ret -1
Call Failed: CAN'T ACCESS DEVICE
exit code 101
```



Conversation Complete: Status FAILED

## 10.2 Monitoring a UUCP File Transfer

Monitoring a UUCP file transfer enables you to diagnose other UUCP problems, especially if you can already establish a remote UUCP connection.

To monitor a file transfer, do the following:

1. Verify the status of the files in the spooling directory on your local system by using the `uustat -q` command.
2. Verify that the local system can contact the remote system by using the `uutry system_name` command.
3. If the debugging output indicates that the connection was not successful, follow the steps described in Section 10.1 to test the remote connection..
4. Prepare a file for transfer by using the `uucp -r` command. The `-r` option instructs the `uucp` utility to place the file in the queue without starting the `uucico` daemon.

Start the file transfer by using the `uutry` command.

See `uutry(1)` for additional information on this command.

The following example sends the `test1` file to the system `host6`:

```
# uucp -r test1 host6! ~/test1
# /usr/lib/uucp/uutry host6
```

## 10.3 Viewing the Error Log File

To diagnose kernel and hardware errors, you can look at the system events that occurred prior to the errors. Messages from system events, such as error messages relating to the software kernel and system hardware, and informational messages about system status, startup, and diagnostics, are recorded in the binary error log file, `/var/adm/binary.errlog`.

Because this log file is in binary format, the operating system offers special utilities, `DECEvent` and `Compaq Analyze`, that read the binary log file and run the data through a formatter to display the information. See `dia(8)` and `ca(8)` for more information about `DECEvent` and `Compaq Analyze`, respectively.

Note that these utilities are not available in the operating system by default; you must install the Web-Based Enterprise Services (WEBES) kit, a suite of diagnostic utilities, to obtain them. WEBES is available for installation from the Associated Product CD-ROMs or for download from the following URL:

**<http://www.support.compaq.com/svctools/webes>**

See the *System Administration* manual for information about using the Event Viewer to present errors as interpreted by DECEvent and Compaq Analyze. Also, see `uerf(8)` for an alternative to these utilities.

## 10.4 Viewing the syslogd Daemon Message Files

You can use the `syslogd` daemon to help diagnose session layer problems such as access control problems for the Internet Protocol Version 4 (IPv4) and Internet Protocol Version 6 (IPv6).

The `syslogd` daemon starts running when you boot the system and whenever it receives a hangup signal. By default, it records the system messages for these events in a set of files in the `/var/adm/syslog.dated` directory (as specified in the `/etc/syslog.conf` file). The system messages can indicate error conditions or warnings, depending on the priority codes they contain.

Although it is possible to review the contents of the system message files from the command line, it is best to use the Event Viewer that is part of the SysMan Menu utility, because it simplifies access to the files and makes it easier for you to find particular problems.

To start the Event Viewer, invoke the SysMan Menu as described in Section 1.2.1, then select Monitoring and Tuning→View events. Alternatively, you can invoke the Event Viewer from a command line by entering the following command:

```
# /usr/bin/sysman event_viewer
```

Once the Event Viewer is displayed, you can use it to sort the log entries, filter the entries (for a certain event name, priority level, posting host, or date), and obtain more detailed information about individual entries.

For more information about event management and accessing the system log files, see `evm(5)`, `syslogd(8)`, the *System Administration* manual, and the online help.

---

## Testing DNS Servers

In concept, testing DNS/BIND servers consists of locating the information you need. In practice, testing DNS servers involves tracing through a network of servers and their databases to find the server responsible for the information. This section describes the tests you can use to locate the information.

### 11.1 Glossary

The following terms are used in this section. Refer to them as needed during the problem solving tests.

**authoritative server**

A server that stores information locally. Master and slave servers are examples of authoritative servers. They have primary and secondary authority, respectively, for a given domain.

In contrast, a server that is not authoritative must ask other servers for information about the target host. A forward-only server is an example of this type of server because it forwards queries to a list of forwarders that can answer such requests.

**current server**

The server you are currently logged in to and running tests from.

**data types**

The types of resource records in the DNS database files. See `named(8)` for a complete list and explanation.

**forwarder**

A server that can answer DNS queries from data in its databases and cache, whether or not it is authoritative for the information. Forwarder entries can be in the `named.conf` file.

**nameserver (NS) record**

Nameserver records map a domain name to a system that serves the domain, and determine whether a system is familiar with the name servers for the authoritative domain. Nameserver records have the following form:

```
domain-name           IN      NS      machine-name
```

On the left is the domain name; on the right is the name of the machine that services the domain.

**master server**

A server that stores the main copy of a target domain's databases. A master server has primary authority for name service information in a given domain.

**slave server**

A server that pulls a copy of the target domain's data from another server. In most cases, the data is pulled from a master server. However, in some cases, the data is pulled from another slave server.

A slave server has secondary authority for name service information in a given domain.

**start of authority (SOA) record**

Start of authority records mark the start of a zone of authority. They occur at the beginning of each master database file. SOA records have the following form:

*domain-name*                    IN            SOA            *machine-name*

**target domain name**

The portion of the target host name that begins after the first period (.).

**target host**

The host name you are trying to resolve. The target domain name is derived from the target host name.

## 11.2 DNS Server Testing Worksheet

Figure 11–1 shows the DNS Server Testing Worksheet, which you can use to record information from the tests in the following sections. If you are viewing this manual online, you can use the print feature of your browser to print a copy of this worksheet. On a copy of the worksheet, write the current server's name, current domain name, and target domain name.

**Figure 11–1: DNS Server Testing Worksheet**

| DNS SERVER TESTING WORKSHEET |                      |  | Sheet <input style="width: 20px;" type="text"/> of <input style="width: 20px;" type="text"/> |
|------------------------------|----------------------|--|--|
| Current server:              |                      |  |  |
| Server type:                 |                      |  |  |
| Current domain name:         |                      |  |  |
| Target domain name:          |                      |  |  |
| <b>named.conf file</b>       |                      |  |  |
|                              | Server IP address    | Reachable  |  |
| Domain name: _____           |                      | Yes <input type="checkbox"/>                             | No <input type="checkbox"/>  |
| Database file name: _____    |                      | Yes <input type="checkbox"/>                             | No <input type="checkbox"/>  |
| Serial number: _____         |                      | Yes <input type="checkbox"/>                             | No <input type="checkbox"/>  |
| <b>Nameservers</b>           |                      |  |  |
| Nameserver name              | IP address           | Administrative Control                                   | Reachable  |
|                              |                      | Yes <input type="checkbox"/> No <input type="checkbox"/> | Yes <input type="checkbox"/> No <input type="checkbox"/>                                     |
|                              |                      | Yes <input type="checkbox"/> No <input type="checkbox"/> | Yes <input type="checkbox"/> No <input type="checkbox"/>                                     |
|                              |                      | Yes <input type="checkbox"/> No <input type="checkbox"/> | Yes <input type="checkbox"/> No <input type="checkbox"/>                                     |
|                              |                      | Yes <input type="checkbox"/> No <input type="checkbox"/> | Yes <input type="checkbox"/> No <input type="checkbox"/>                                     |
| <b>Forwarders</b>            |                      |  |  |
|                              | Forwarder IP address | Administrative Control                                   | Reachable  |
|                              |                      | Yes <input type="checkbox"/> No <input type="checkbox"/> | Yes <input type="checkbox"/> No <input type="checkbox"/>                                     |
|                              |                      | Yes <input type="checkbox"/> No <input type="checkbox"/> | Yes <input type="checkbox"/> No <input type="checkbox"/>                                     |
|                              |                      | Yes <input type="checkbox"/> No <input type="checkbox"/> | Yes <input type="checkbox"/> No <input type="checkbox"/>                                     |
|                              |                      | Yes <input type="checkbox"/> No <input type="checkbox"/> | Yes <input type="checkbox"/> No <input type="checkbox"/>                                     |
| <b>Root nameservers</b>      |                      |  |  |
|                              |                      |  | Cache file: Yes <input type="checkbox"/> No <input type="checkbox"/>                         |
| Nameserver name              | Server IP address    | Server IP address  | Reachable  |
|                              |                      |  | Yes <input type="checkbox"/> No <input type="checkbox"/>                                     |
|                              |                      |  | Yes <input type="checkbox"/> No <input type="checkbox"/>                                     |
|                              |                      |  | Yes <input type="checkbox"/> No <input type="checkbox"/>                                     |
|                              |                      |  | Yes <input type="checkbox"/> No <input type="checkbox"/>                                     |

### 11.3 Starting the DNS Server Test

To determine if the current server can resolve the target data, complete the following steps:

1. Determine whether the current server can access the target data. Use the following commands:

```
# nslookup
Default Server: host1.corp.com
Address: 127.0.0.1

> server localhost
Default Server: localhost.corp.com
Address: 127.0.0.1

> set timeout=45
> set retry=2
> target_host.target_domain.
```

---

| <b>If the nslookup command:</b> | <b>Action:</b>  |
|---------------------------------|---|
| Succeeds                        | Go to step 3.   |
| Fails                           | If the first time, go to step 2.<br>If the second time, go to Section 11.4. |

---

- Determine whether the named daemon is running by using the following command:

```
# ps gax | grep named
```

---

| <b>If the named daemon is:</b> | <b>Action:</b>  |
|--------------------------------|---|
| Running                        | Go to step 1.   |
| Not running                    | Start the daemon by using the <code>/sbin/init.d/named start</code> command. If the Internet name service started message is displayed, go to step 1.<br><br>If the message is not displayed, this machine is not configured as a DNS server. Decide how the machine is to be configured. See Section 2.5 for more information. |

---

- Log in to the client system and use the `nslookup` command to try to access the target data.

| If the <code>nslookup</code> command: | Action:  |
|---------------------------------------|--|
| Succeeds                              | STOP. The client can resolve the target data.  |
| Fails                                 | The server knows the information, but is not transferring it to the client. Log out from the client; restart DNS on the server by using the <code>/sbin/init.d/named restart</code> command; log in to the client; and use the <code>nslookup</code> command. If it cannot resolve the target data, you have the wrong server or the DNS server is malfunctioning. |

## 11.4 Determining the Server Type

To determine whether the current server is a master server or a slave server, complete the following steps:

1. Compare the target domain name with all domain names of the master and slave entries in the `/etc/named.conf` file. These entries have the following form:

```
zone "domain" {      type server-type;      file
"filename.db"; };
```

The following example shows the `zz.bb.cc.` target domain and subsets of this target domain:

```
# cat /etc/named.conf
:
options {
    directory "/etc/namedb";
};

zone "aa.bb.cc" { 1
    type master;
    file "aa.bb.cc.db";
};

zone "cc" { 2
    type master;
    file "cc.db";
};

zone "bb.cc" { 3
    type slave;
    file "bb.cc.db";
    masters {
        128.102.0.42;
    };
};
```

```

zone "zz.bb.cc" { 4
    type slave;
    file "zz.bb.cc.db";
    masters {
        128.102.29.73;
    };
};
:

```

- 1 This zone entry is not a subset of the zz.bb.cc. domain.
- 2 This zone entry is a subset of the zz.bb.cc. domain. The server is a master server for the cc. domain and it stores the information for this domain in the cc.db file.
- 3 This zone entry is a subset of the zz.bb.cc. domain. The server is a slave server for the bb.cc. domain and it stores the information for this domain in the bb.cc.db file.
- 4 This zone entry matches the zz.bb.cc. domain. The server is a slave server for the zz.bb.cc. domain and it stores the information for this domain in the zz.bb.cc.db file.

For more information on the format of the `named.conf` file, see `named.conf(8)` and the *BIND Configuration File Guide*.

When directed, record information in the `named.conf` file section on the worksheet.

| <b>If a <code>named.conf</code> entry:</b>                | <b>And the type is:</b> | <b>Action:</b>   |
|---|-------------------------|--|
| Matches the target domain name                            | Master                  | Write the server type, domain name, and database file name on the worksheet and go to Section 11.8.                    |
|   | Slave                   | Write the server type, domain name, database file name, and host IP addresses on the worksheet and go to Section 11.7. |
| Is a subset of the target domain name                     | Master                  | Write the server type, domain name, and database file name on the worksheet and go to step 2.                          |
|   | Slave                   | Write the server type, domain name, database file name, and host IP addresses on the worksheet and go to step 2.       |
| Neither matches nor is a subset of the target domain name | Master or slave         | Go to Section 11.5.  |



- Compare the target domain name with all nameserver (NS) records in the database file recorded on the worksheet. When directed, record information in the Nameservers section on the worksheet. Use the following commands to create and view a list of NS records:

```
# grep -n NS database_file > ns_list
# grep -n ORIGIN database_file >> ns_list
# sort -n ns_list > ns_list.srt
# cat ns_list.srt
```

The following example shows the file created by these commands. The target domain is zz.bb.cc.:

```
# cat ns_list.srt
1:$ORIGIN cc.
10:                IN          NS           server_1.cc.
17:$ORIGIN cc.
18:bb              IN          NS           server_3.bb.cc.
21:$ORIGIN cc.
22:bb              IN          NS           server_4.bb.cc.
41:$ORIGIN bb.cc.
42:zz              IN          NS           server_5.zz.bb.cc. 1
45:$ORIGIN bb.cc.
46:zz              IN          NS           server_6.bb.cc. 2
```

- 1 This entry is a longer subset (exact match) of the target domain. The domain name from the preceding \$ORIGIN line, .bb.cc., is appended to the domain name of this line, zz, resulting in zz.bb.cc..
- 2 This entry is a longer subset (exact match) of the target domain. The domain name from the preceding \$ORIGIN line, .bb.cc., is appended to the domain name of this line zz, resulting in zz.bb.cc..

| If any NS record:  | And the server is: | Action:  |
|--|--------------------|--|
| Contains a longer subset of the target domain name than the domain name on the worksheet         | Master or slave    | The server has neither primary nor secondary authority for the target information. Write the names of the servers on the worksheet and go to step 3. |
| Does not contain a longer subset of the target domain name than the domain name on the worksheet | Master             | The database files contain the target information. Go to Section 11.8.   |
|  | Slave              | The database files contain the target information. Go to Section 11.7.   |

- Find the IP addresses in the database file for any name servers on the worksheet. Use the following commands:

```
# grep -n ORIGIN database_file > ip_list
# grep -n server_name database_file >> ip_list
:
# sort -n ip_list > ip_list.srt
# cat ip_list.srt
```

Write the IP addresses on the worksheet next to the corresponding server name and go to Section 11.5. The following example shows the file created by the preceding commands:

```
# cat ip_list.srt
1:$ORIGIN cc.
17:$ORIGIN cc.
21:$ORIGIN cc.
41:$ORIGIN bb.cc.
42:zz          IN          NS          server_5.zz.bb.cc.
43:$ORIGIN zz.bb.cc.
44:server_5    IN          A           10.140.48.3 [1]
45:$ORIGIN bb.cc.
46:zz          IN          NS          server_6.bb.cc.
47:$ORIGIN bb.cc.
48:server_6    IN          A           10.12.48.3 [2]
```

[1] The IP address for server\_5 is 10.140.48.3.

[2] The IP address for server\_6 is 10.12.48.3.

## 11.5 Finding the Target Domain Information

To determine the servers that the current server communicates with in order to get information for the target domain, complete the following steps:

1. Search the `named.conf` file and find any forwarder entries. These entries have the following form:

```
options {
    directory "directory-name";
    forward only;
    forwarders {
        IP-address;
        IP-address;
    };
};
```

When directed, record information in the Forwarders section on the worksheet.

| <b>If your system:</b>            | <b>Action:</b>   |
|-----------------------------------|--|
| Contains a forwarder line         | The current server forwards requests. Write the IP addresses for any forwarders on the worksheet and go to Section 11.6. |
| Does not contain a forwarder line | The current server does not forward queries. Go to step 2.   |

2. Compare the target domain name with all nameserver (NS) records in the database file recorded on the worksheet. When directed, record information in the Nameserver section on the worksheet.

Use the following commands to create and view a list of NS records for each database file:

```
# grep -n NS database_file > ns_list
# grep -n ORIGIN database_file >> ns_list
# sort -n ns_list > ns_list.srt
# cat ns_list.srt
```

| <b>If any NS record:</b>   | <b>And:</b>                                      | <b>Action:</b>  |
|--|--|---|
| Contains a longer subset of the target domain name than the domain name on the worksheet         | →  | Write the names of the servers on the worksheet and go to step 3. |
| Does not contain a longer subset of the target domain name than the domain name on the worksheet | The Nameserver section on the worksheet is blank | Go to Section 11.9.   |

3. Find the IP addresses in the database file for any name servers on the worksheet. Use the following commands:

```
# grep -n ORIGIN database_file > ip_list
# grep -n server_name database_file >> ip_list
:
# sort -n ip_list > ip_list.srt
# cat ip_list.srt
```

Write the IP addresses on the worksheet next to the corresponding server name and go to step 4.

4. Verify whether each server listed in the Nameserver section on the worksheet is reachable by using the ping command.

| <b>If a server:</b>                  | <b>And:</b>                               | <b>Action:</b>  |
|--------------------------------------|---|---|
| Responds to the ping command         | You have root access to the server        | The server is reachable and under your administrative control. Note both items on the worksheet. Go to step 5.  |
|                                      | You do not have root access to the server | The server is reachable, but not under your administrative control. Note both items on the worksheet. Go to step 5.   |
| Does not respond to the ping command | →   | Note this on the worksheet.   |
|                                      |   | If no servers responded to the ping command, STOP. The current server is isolated from its servers on the network. You cannot solve the problem; contact your enterprise network administrator. |

5. Log in to each reachable server by using the telnet command. Each server you log in to becomes the current server. Get a new worksheet and write the current server name, current domain name, and target domain name on it. For each server, perform the DNS server test. See Section 11.3.

## 11.6 Testing the Forwarders

To determine whether the forwarders prevent you from resolving the target host name, complete the following steps:

1. Determine whether each forwarder listed on the worksheet is reachable by using the ping command.

| <b>If a forwarder:</b>       | <b>And:</b>                                  | <b>Action:</b>   |
|------------------------------|--|--|
| Responds to the ping command | You have root access to the forwarder        | The forwarder is reachable and under your administrative control. Note both items on the worksheet. Go to step 2.      |
|                              | You do not have root access to the forwarder | The forwarder is reachable, but not under your administrative control. Note both items on the worksheet. Go to step 2. |

| <b>If a forwarder:</b>               | <b>And:</b> | <b>Action:</b>   |
|--------------------------------------|-------------|--|
| Does not respond to the ping command | →           | Note this on the worksheet.<br><br>If no forwarders responded to the ping command, STOP. The current server is isolated from its forwarders on the network. You cannot solve the problem; contact your enterprise network administrator. |

2. Edit the `named.conf` file and eliminate any forwarders that did not respond to the ping command.
3. Enter the `nslookup` command again for the target host.

| <b>If the nslookup command:</b> | <b>Action:</b> |
|---------------------------------|----------------|
| Succeeds                        | Go to step 4.  |
| Fails                           | Go to step 5.  |

4. Edit the `named.conf` file and add the forwarders removed in step 2 at the end of the forwarders line. In addition, contact the administrators of forwarders not under your administrative control and inform them that they might have a problem with their forwarder. STOP.
5. Log in to each reachable forwarder by using the `telnet` command. This forwarder is now the current server. On a new worksheet, write the current server name, current domain name, and target domain name. For each server, perform the DNS server test. See Section 11.3.

| <b>If the forwarder or other machines:</b> | <b>Action:</b>  |
|--|---|
| Cannot resolve the target name             | Remove the forwarder from <code>named.conf</code> file. |
| Can resolve the target name                | STOP.   |

## 11.7 Testing Slave Servers

To determine whether the slave server contains the target data, complete the following steps:

1. Find the database serial number in the start of authority record in the database file. Use the following command:

```
# head -4 database_file
```

Write the first number, which is the serial number, on the worksheet in the `named.conf` section. If you have a serial number on a previous worksheet, compare the current serial number with that one. Note whether the current number is larger (newer) or smaller (older) than the other number. In the following example, 23 is the serial number:

```
# head -4 database_file
$ORIGIN cc.
bb      IN      SOA      host1.bb.cc. postmaster.host1.bb.cc. (
        23 300 60 1209600 43200 )
        IN      MX      100 host1.bb.cc.
```

2. Determine whether the target data is contained in the database file written on the worksheet. Use the following commands to create and view a list of resource records:

```
# grep -n data_type database_file > ns_list
# grep -n ORIGIN database_file >> ns_list
# sort -n ns_list > ns_list.srt
# cat ns_list.srt
```

| If the database file:              | And the serial number is: | Action:  |
|------------------------------------|---------------------------|--|
| Contains the target data           | Newer                     | The data exists in the domain. Go to step 3.   |
| Contains the target data           | Older or same             | The server is malfunctioning or you made a error. Verify all steps up to this point. |
| Does not contain the target data → |                           | The data does not exist in the domain. Go to step 4.                                 |

3. Determine whether the current server can access the target data. Use the following commands:

```
# nslookup
Default Server: host1.corp.com
Address: 127.0.0.1

> server localhost
Default Server: localhost.corp.com
Address: 127.0.0.1

> set timeout=45
> set retry=2
> target_host.target_domain.
```

| <b>If the nslookup command:</b> | <b>And the database serial number is:</b> | <b>Action:</b>   |
|---------------------------------|---|--|
| Succeeds                        | →   | STOP. The server is working. Either the client or server cannot communicate with the server or this server just started working. |
| Succeeds                        | Newer                                     | Log out of the slave server. Get the previous slave server's worksheet and go to step 8.   |
| Fails                           | →   | Restart the current slave server by using the /sbin/init.d/named restart command. Then reenter the nslookup command.             |

4. Verify whether each name server listed on the worksheet is reachable by using the ping command.

| <b>If a server:</b>                  | <b>And:</b>                               | <b>Action:</b>   |
|--------------------------------------|---|--|
| Responds to the ping command         | You have root access to the server        | The server is reachable and under your administrative control. Note both items on the worksheet.   |
|                                      | You do not have root access to the server | The server is reachable, but not under your administrative control. Note both items on the worksheet.  |
| Does not respond to the ping command | →   | Note this on the worksheet.<br><br>If no servers responded to the ping command, STOP. The current server is isolated from its servers on the network. You cannot solve the problem; contact your enterprise network administrator. |

Count the number of servers that responded to the ping command and that are under your administrative control. If the number is zero (0), go to Section 11.10.

5. Edit the `named.conf` file and find the `slave` entry. Delete the IP address for those servers that are not reachable and are not under your administrative control. Delete those entries from the worksheet as well.
6. Log in to each reachable server by using the `telnet` command. Start a new worksheet for each server, writing the server name as the current server. Save the old worksheet.
7. Compare the target domain name with all domain names of the master and slave entries in the `/etc/named.conf` file. These entries have the following form:

```
zone "domain" {
    type server-type;
    file "filename.db";
};
```

When directed, record information in the `named.conf` file section on the worksheet.

| If a <code>named.conf</code> entry:                       | And the first field is: | Action:   |
|---|-------------------------|---|
| Matches the target domain name                            | Master                  | Write the domain name and database file name on the worksheet and go to Section 11.8.                   |
|   | Slave                   | Write the domain name, host IP addresses, and the database file name on the worksheet and go to step 1. |
| Is a subset of the target domain name                     | →                       | STOP. Examine another master or slave server entry.   |
| Neither matches nor is a subset of the target domain name | →                       | STOP. Examine the next master or slave server entry.  |

8. Restart the current slave server by using the following command:

```
# /sbin/init.d/named restart
```

After restarting, wait a few minutes before proceeding to the next step. This allows time for the database to be updated.

9. Determine whether the current server can access the target data. Use the following commands:

```
# nslookup
Default Server: host1.corp.com
Address: 127.0.0.1

> server localhost
```



```
Default Server: localhost.corp.com
Address: 127.0.0.1
```

```
> set timeout=45
> set retry=2
> target_host.target_domain.
```

---

**If the nslookup command: Action:**

---

|          |   |
|----------|---|
| Succeeds | STOP. The server is working. If you are in a telnet session to another slave server, log out and go to step 8.  |
| FAILS    | If you just ended a telnet session to another server, go to step 10.<br><br>If you did not end a telnet session, either the current server is malfunctioning and cannot read the database file or you made an error. Verify all steps up to this point. |

---

10. Compare the database serial number of the current server with the database serial number of the server from which you just logged out. Use the following command:

```
# head -4 database_file
```

---

**If the current database serial number is: Action:**

---

|          |   |
|----------|---|
| Older    | Either the server cannot pull the database from the authoritative server or you made an error. Verify all steps up to this point. |
| The same | The serial numbers cannot be equal. Verify all steps up to this point.  |

---

## 11.8 Testing Master Servers

To determine whether the master server contains the target data, complete the following steps:

1. If you are in a telnet session from a slave server to a master server, go to step 2. Otherwise, go to step 3.
2. Find the database serial number in the start of authority record in the database file. Use the following command:

```
# head -4 database_file
```

Write the first number, which is the serial number, on the worksheet in the `named.conf` section. If you have a serial number on a previous worksheet, compare the current serial number with that one. Note

whether the current number is larger (newer) or smaller (older) than the other number. In the following example, 23 is the serial number:

```
# head -4 database_file
$ORIGIN cc.
bb      IN      SOA      host1.bb.cc. postmaster.host1.bb.cc. (
        23 300 60 1209600 43200 )
        IN      MX      100 host1.bb.cc.
```

- Determine whether the target data is contained in the database file written on the worksheet. Use the following commands to create and view a list of resource records:

```
# grep -n data_type database_file > ns_list
# grep -n ORIGIN database_file >> ns_list
# sort -n ns_list > ns_list.srt
# cat ns_list.srt
```

| If the database file:            | Action:  |
|----------------------------------|--|
| Contains the target data         | The data exists in the domain. Go to step 4.         |
| Does not contain the target data | The data does not exist in the domain. Go to step 5. |

- Determine whether the current server can access the target data. Use the following commands:

```
# nslookup
Default Server: host1.corp.com
Address: 127.0.0.1

> server localhost
Default Server: localhost.corp.com
Address: 127.0.0.1

> set timeout=45
> set retry=2
> target_host.target_domain.
```

| If the nslookup command: | And the database serial number is: | Action:  |
|--------------------------|------------------------------------|--|
| Succeeds                 | →                                  | STOP. The server is working. Either the last server cannot communicate with this server or this server just started working. |
| Succeeds                 | Older or same                      | STOP. The server is malfunctioning or you made an error. Verify all steps up to this point.                                  |

| If the <code>nslookup</code> command: | And the database serial number is: | Action:   |
|---------------------------------------|------------------------------------|---|
| Succeeds                              | Newer                              | Log out of the master server. Get the previous slave server's worksheet and go to step 8 in Section 11.7.                                       |
| Fails                                 | →                                  | Restart the current master server by using the <code>/sbin/init.d/named restart</code> command. Then reenter the <code>nslookup</code> command. |

5. Edit the database file and increment the database serial number by 1 to age the database. The following example shows the SOA record before and after editing. Note the serial number increase from 23 to 24.

```
# head -4 database_file
$ORIGIN cc.
bb      IN      SOA      host1.bb.cc. postmaster.host1.bb.cc. (
        23 300 60 1209600 43200 )
        IN      MX      100 host1.bb.cc.
# vi database_file
:
:
# head -4 database_file
$ORIGIN cc.
bb      IN      SOA      host1.bb.cc. postmaster.host1.bb.cc. (
        24 300 60 1209600 43200 )
        IN      MX      100 host1.bb.cc.
```

6. Edit the database file and add new data to the database. Refer to Section 11.1 for information on valid data types. Precede any new entry with a `$ORIGIN` entry, and separate database fields with a tab character. The following example shows a new address record for host `host1.bb.cc.`:

```
$ORIGIN bb.cc
host1      IN      A      16.141.112.11
```

7. Restart the master server by using the following command:

```
# /sbin/init.d/named restart
```

8. Determine whether the current server can access the target data. Use the following commands:

```
# nslookup
Default Server: host1.corp.com
Address: 127.0.0.1

> server localhost
Default Server: localhost.corp.com
Address: 127.0.0.1

> set timeout=45
> set retry=2
> target_host.target_domain.
```

| <b>If the <code>nslookup</code> command:</b> | <b>Action:</b>  |
|--|---|
| Succeeds                                     | Log out of the master server. Get the previous slave server's worksheet and go to step 8 in Section 11.7. |
| Fails  | Either the server is malfunctioning or you made an error. Verify all steps up to this point.              |

## 11.9 Tracing Information from the Root Name Server

To resolve the target name beginning with the root of the DNS namespace, complete the following steps:

1. Determine whether the current server has a cache file containing the information necessary to find a root server. Use the following command:

```
# grep cache /etc/named.conf
```

| <b>If a cache line:</b> | <b>Action:</b>   |
|-------------------------|--|
| Does not exist          | The current server cannot contact a root name server. Note this on the worksheet and go to step 2. |
| Exists                  | Note this on the worksheet and go to step 3.   |

2. Add a cache file to your server.

### Caution

Adding a cache file alters many system files. Perform the following steps as shown to ensure the correct operation of your system.

- a. Create copies of specific DNS and system files. Enter the following commands:

```
# cd /etc
# cp -r namedb namedb.back
# cp rc.config.common rc.config.common.back
# cp hosts hosts.back
# cp resolv.conf resolv.conf.back
# cp svc.conf svc.conf.back
# cd /var/adm/sendmail
# cp sendmail.cf sendmail.cf.back
```

- b. Display the name of the local host by using the `hostname` command. You will need to reset the host name after running the SysMan Menu utility and copying system files.

- c. Run the SysMan Menu utility. Modify the configuration and create a caching server (see Section 2.5.3). Do not start the DNS daemon automatically and do not run `svcsetup`.
- d. Copy the system files to the `/etc` directory. Use the following commands:

```
# cd /etc
# cp rc.config.common.back rc.config.common
# cp hosts.back hosts
# cp resolv.conf.back resolv.conf
# cp svc.conf.back svc.conf
```

- e. Set the host name to the original host name by using the `hostname` command.
- f. Copy the `sendmail` file to the `/var/adm/sendmail` directory and restart `sendmail`. Use the following commands:

```
# cd /var/adm/sendmail
# cp sendmail.cf.back sendmail.cf
# /sbin/init.d/sendmail restart
```

- g. Copy the DNS files to the `/etc` directory. Use the following commands:

```
# cd /etc
# cp namedb/namedb.boot namedb.back/named.conf_new
# cp namedb/namedb.ca namedb.back
# rm -rf namedb.back namedb
# mv namedb.back namedb
# cd namedb
```

- h. Edit the `named.conf` file and add the following lines to the end of the file:

```
zone "." {
    type hint;
    file "named.ca";
};
```

- i. Remove the `named.conf_new` file.
- j. Restart the current server by using the `/sbin/init.d/named restart` command.

3. Display the `named.ca` file by using the following command:

```
# cat named.ca
```

Write the root name server names and IP addresses in the Root nameservers section on the worksheet.

4. Verify whether each root name server listed on the worksheet is reachable by using the `ping` command.

| <b>If a root name server:</b>        | <b>Action:</b>   |
|--------------------------------------|--|
| Responds to the ping command         | Note this on the worksheet. Go to Section 11.11.                                       |
| Does not respond to the ping command | Note this on the worksheet. If no servers responded to the ping command, go to step 5. |

5. Do either of the following:

- Give the current server access to the Internet. Then restart the named daemon by using the following command:

```
# /sbin/init.d/named restart
```

Keep the current server and worksheet, and go to Section 11.3.

- Add a forwarder entry to direct the current server to communicate with a machine with Internet access. Then restart the named daemon by using the following command:

```
# /sbin/init.d/named restart
```

Keep the current server and worksheet, and go to Section 11.3.

## 11.10 Resolving Target Data

To resolve target data using a name server, complete the following steps:

1. Enter the `nslookup` command for the target system. Choose the first name server from either the Root nameserver section or the Nameserver section. Use the following commands:

```
current_server> nslookup
Default Server: localhost.omni.corp.com
Address: 127.0.0.1
```

```
> server IP_address
Default Server: [IP_address]
Address: 128.102.16.10
```

```
> set type data_type
> target_name
```

| <b>If the nslookup command:</b> | <b>And:</b>                       | <b>Action:</b>   |
|---------------------------------|-----------------------------------|--|
| Succeeds                        | →                                 | STOP. The server is working. Either the last server you tested does not talk to this one or this server just started working. Verify all steps completed up to this point.   |
| Fails                           | An error message is returned.     | <p>If a “non-existent domain” message is displayed, no data exists for the <i>target_name</i>. Go to Section 11.11.</p> <p>If a “no information available” message is displayed, the <i>target_name</i> exists, but is not associated with the target data. If the data is required, contact the target domain administrator and request that the data be added to the domain.</p> <p>If a “timed-out” message is displayed, the server to which you sent the query cannot contact the server that is responsible for the target data. Go to step 2.</p> |
| Fails                           | An error message is not returned. | An unknown error. Contact the target domain administrator.   |

2. Modify the retry and timeout values and re-enter the nslookup command. Enter the following commands:

```

current_server> nslookup
Default Server: localhost.omni.corp.com
Address: 127.0.0.1

> server IP_address
Default Server: [IP_address]
Address: IP_address

> set type data_type
> target_name

```

| <b>If the nslookup command:</b> | <b>And:</b>                      | <b>Action:</b>   |
|---------------------------------|----------------------------------|--|
| Succeeds                        | →                                | STOP. The server is working, but is slow. This might prevent the query from being resolved. If the network connection to the server is correct, wait two or three hours for the performance to improve. If it does not improve, contact the server administrator.  |
| Fails                           | An error message is returned     | <p>If a “non-existent domain” message is displayed, no data exists for the <i>target_name</i>. Go to Section 11.11.</p> <p>If a “no information available” message is displayed, the <i>target_name</i> exists, but the target data is not associated with it. If the data is required, contact the target domain administrator and request that the data be added to the domain.</p> <p>If a “timed-out” message is displayed, the server to which you sent the query cannot access the server that is responsible for the data. Select another nameserver from the worksheet and go to step 1.</p> |
| Fails                           | An error message is not returned | An unknown error. Contact the target domain administrator.   |

## 11.11 Finding the First Nonexistent Domain

To find the first nonexistent domain in a target name, complete the following steps:

1. Enter the `nslookup` command, using the smallest subset of the target domain name. Enter the following commands:

```
current_server> nslookup
Default Server: localhost.omni.corp.com
Address: 127.0.0.1

> server IP_address
Default Server: [IP_address]
Address: IP_address

> set type=ns
> target_name_subset
```



For example, if the target domain name is `zz.bb.cc.`, the first attempt is to resolve the target name subset `cc.`. If necessary, the second attempt uses `bb.cc.`, and the third, `zz.bb.cc.`.

| If the <code>nslookup</code> command: | And:                         | Action:  |
|---------------------------------------|------------------------------|--|
| Succeeds                              | →                            | Go to step 3.  |
| Fails                                 | An error message is returned | If a “non-existent domain” message is displayed, no data exists for the <code>target_name</code> . If the data is required, contact the domain administrator and request that the data be added to the domain. STOP.<br><br>If a “timed-out” message is displayed, go to step 2. |

2. Modify the retry and timeout values and enter the `nslookup` command again. Enter the following commands:

```
current_server> nslookup
Default Server: localhost.omni.corp.com
Address: 127.0.0.1

> server IP_address
Default Server: [IP_address]
Address: IP_address

> set retry=2
> set timeout=45
> set type=ns
> target_name_subset
```

| If the <code>nslookup</code> command: | And:                         | Action:  |
|---------------------------------------|------------------------------|--|
| Succeeds                              | →                            | Go to step 3.  |
| Fails                                 | An error message is returned | If a “non-existent domain” message is displayed, no data exists for the <code>target_name</code> . If the data should exist, contact the domain administrator and request that the data be added to the domain. STOP.<br><br>If a “timed-out” message is displayed, select another name server from the worksheet and go to Section 11.10. |

3. Add the next part of the target domain name to the target subset and go to step 1.



---

## Reporting Network Problems

If you are unable to solve a critical problem with the network or network service, do the following:

1. Read the release notes for the product to see if the problem is known. If it is, follow the solution offered to solve the problem.
2. Determine whether the product is still under warranty or whether your company purchased support services for the product. Your operations manager can supply you with the necessary information.
3. If either condition in step 2 was met, take one of the following actions:
  - a. Access the online service database, if you have purchased this service, and determine if the problem you are experiencing has already been reported. If it has not, log your problem.
  - b. Call your service representative and describe the problem.
4. If you are requested to supply any information pertaining to the problem, gather the necessary information and submit it.

You might be asked to submit some information that can help isolate problems to a particular area of the system and speed the resolution of the problem. It is a good idea to keep all basic information in a `system.information` file. Then you can easily include it with your problem report.

The following sections describe some of the information that you might be asked to submit.

### 12.1 Gathering General Information

Gather the following information about your system:

- The operating system version and revision number (from the `/etc/motd` file). Add this to the `system.information` file.
- A description of your system's activity before the error.
- A listing of the exact command line or lines executed and the output.

- A copy of the application source code, if running a user-created application. If possible, include a sample test program that demonstrates the problem.

## 12.2 Gathering Hardware Architecture Information

Gather the following information about the hardware architecture:

- A description of the model of the workstation or server (from the `/usr/sys/conf/HOSTNAME` file), including the type of graphics controller (if a workstation), the amount of memory, and third-party hardware

- A description of the X server

To determine which type you are running, enter the following command:

```
# ps ax | grep /usr/bin/X >> system.information
```

- A description of the disks used and the size of your swap partition

For example, if your system disk is unit 0, enter the following commands as root to add this information to the `system.information` file:

```
# disklabel -r /dev/rrz0a >> system.information
# echo df: >> /system.information
# df >> /system.information
# echo mount: >> /system.information
# mount >> /system.information
# echo xdpinfo: >> /system.information
# xdpinfo >> /system.information
```

- Any networking information

To add this to the `system.information` file, enter the following commands:

```
# echo netstat: >> /system.information
# netstat -i -n >> system.information
# netstat -r -n >> /system.information
# echo nslookup: >> /system.information
# nslookup localhost >> /system.information
```

- Any event logging information

To add this to the `system.information` file, enter the following commands:

```
# uerf -R -o full | head -200 >> /system.information
```

## 12.3 Gathering Software Architecture Information

Gather the following information about the software architecture:

- A description of the software subsets installed

To add this to the `system.information` file, enter the following commands:

```
# echo setld: >> /system.information
# setld -i >> /system.information
```

- The output of the `setld` log file

To add this to the `system.information` file, enter the following command:

```
# pr /usr/adm/smlogs/setld.log >> /system.information
```

- The automatic reboot file

To add this to the `system.information` file, enter the following commands:

```
# pr /etc/rc.config* >> /system.information
# pr /sbin/rc[023] >> /system.information
# pr /sbin/init.* >> /system.information
```

- A description of the layered products installed



# A

---

## Writing Automount and AutoFS Maps

There are three types of Automount or AutoFS maps:

---

### Note

---

The Automount daemon will be retired in a future release of the operating system. For information about migrating from Automount to AutoFS, see Section 4.6.2.4.

---

- Master
- Direct
- Indirect

The maps can be written in a variety of ways. They can be simple or can use multiple mounts, shared mounts, replicated file systems, or any combination of the three. As discussed in Section A.1, indirect maps can be written to reduce redundancy by using substitution characters and pattern matching. The examples in this section illustrate how the same maps can be rewritten in a number of ways.

Figure A-1 illustrates an `auto.master` map that points to the `/etc/auto.direct` direct map, the built-in `-hosts` map, and the `/etc/auto.home` indirect map. Each map to which the `auto.master` map points is expanded to show its sample contents. Note that all of the information contained in the master map can be specified on the command line. The master map, however, simplifies Automount and AutoFS administration.

**Figure A-1: Sample automount Maps**

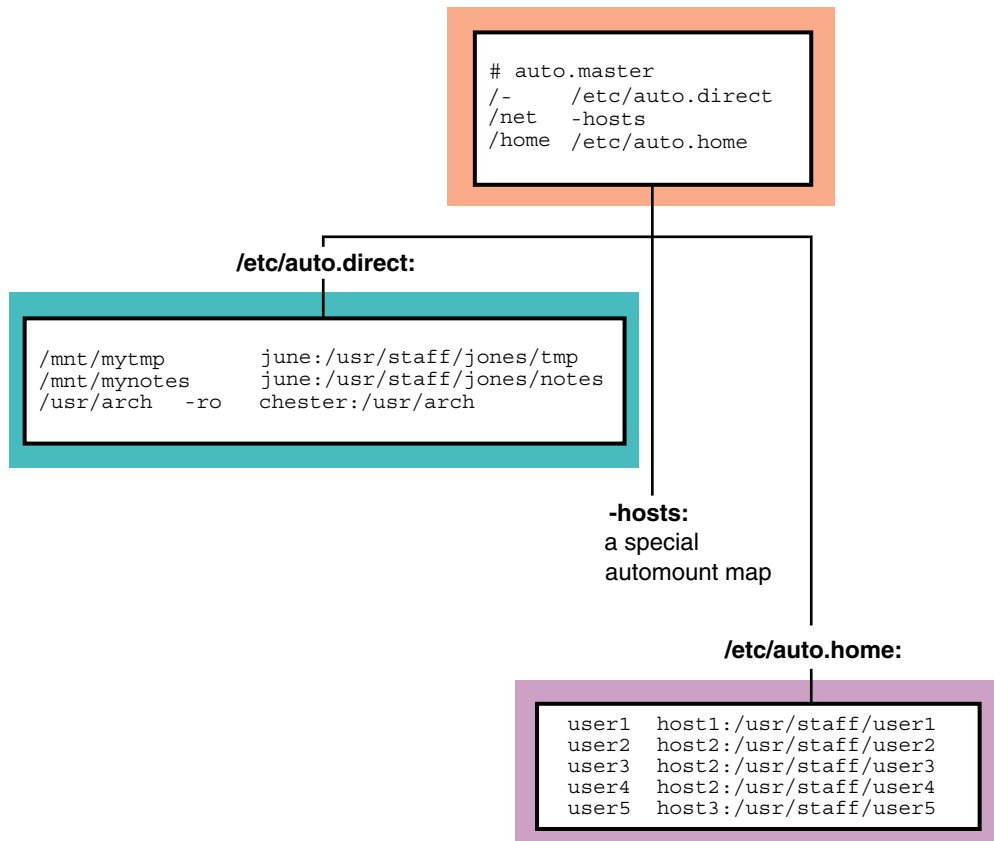

ZK-0464U-AI

The following examples show how the `/etc/auto.direct` map in Figure A-1 can be rewritten using multiple mounts (Example A-1); multiple mounts and shared mounts (Example A-2); and multiple mounts, shared mounts, and replicated file systems (Example A-3).

**Example A-1: Multiple Mounts in a Direct Map**

---

|                           |                          |                  |  |
|---------------------------|--------------------------|------------------|--|
| <code>/mnt/mytmp</code>   |                          |                  | <code>june:/usr/staff/jones/tmp</code>     |
| <code>/mnt/mynotes</code> |                          |                  | <code>june:/usr/staff/jones/notes</code>   |
| <code>/usr/arch</code>    | <code>/</code>           | <code>-ro</code> | <code>chester:/usr/arch \</code>           |
|                           | <code>/bsd</code>        | <code>-ro</code> | <code>chester:/usr/arch/bsd \</code>       |
|                           | <code>/standards</code>  | <code>-ro</code> | <code>chester:/usr/arch/standards \</code> |
|                           | <code>/dec/uws</code>    | <code>-ro</code> | <code>chester:/usr/arch/dec/uws \</code>   |
|                           | <code>/dec/ultrix</code> | <code>-ro</code> | <code>chester:/usr/arch/dec/ultrix</code>  |

---



### Example A-2: Multiple Mounts and Shared Mounts in a Direct Map

---

```
/mnt/mytmp                june:/usr/staff/jones:tmp
/mnt/mynotes              june:/usr/staff/jones:notes
/usr/arch                  /                -ro    chester:/usr/arch \
                          /bsd                -ro    chester:/usr/arch/bsd \
                          /standards          -ro    chester:/usr/arch/standards \
                          /dec/uws             -ro    chester:/usr/arch/dec/uws \
                          /dec/ultrix         -ro    chester:/usr/arch/dec/ultrix
```

---

### Example A-3: Multiple Mounts, Shared Mounts, and Replicated File Systems in a Direct Map

---

```
/mnt/mytmp                june:/usr/staff/jones:tmp
/mnt/mynotes              june:/usr/staff/jones:notes
/usr/arch                  /                -ro    chester:/usr/arch \
                          /bsd                -ro    chester:/usr/arch/bsd \
                          /standards          -ro    chester:/usr/arch/standards \
                          /dec/uws             -ro    chester:/usr/arch/dec/uws \
                          /dec/ultrix         -ro    chester:/usr/arch/dec/ultrix
                          /dec/ultrix         -ro    fiesta:/archive/uws\
```

---

The `/etc/auto.direct` maps in the preceding examples could be rewritten as indirect maps. If the `/etc/auto.direct` map is rewritten to be an indirect map, the entry pointing to it in the `auto.master` map would look like the following:

```
/mnt    /etc/auto.indirect
```

Rewritten as a simple indirect map (`/etc/auto.indirect`), the `/etc/auto.direct` map in Figure A-1 would read as shown in Example A-4.

### Example A-4: Simple Indirect Map

---

```
mytmp          june:/usr/staff/jones/tmp
mynotes        june:/usr/staff/jones/notes
arch    -ro    chester:/usr/arch
```

---

Note that the key is a simple pathname.

The following examples illustrate that indirect maps can also be rewritten using multiple mounts (Example A-5); multiple mounts and shared mounts

(Example A-6); and multiple mounts, shared mounts, and replicated file systems (Example A-7).

#### Example A-5: Multiple Mounts in an Indirect Map

---

|         |             |     |                               |
|---------|-------------|-----|-------------------------------|
| mytmp   |             |     | june:/usr/staff/jones/tmp     |
| mynotes |             |     | june:/usr/staff/jones/notes   |
| arch    | /           | -ro | chester:/usr/arch \           |
|         | /bsd        | -ro | chester:/usr/arch/bsd \       |
|         | /standards  | -ro | chester:/usr/arch/standards \ |
|         | /dec/uws    | -ro | chester:/usr/arch/dec/uws \   |
|         | /dec/ultrix | -ro | chester:/usr/arch/dec/ultrix  |

---

#### Example A-6: Multiple Mounts and Shared Mounts in an Indirect Map

---

|         |             |     |                               |
|---------|-------------|-----|-------------------------------|
| mytmp   |             |     | june:/usr/staff/jones:tmp     |
| mynotes |             |     | june:/usr/staff/jones:notes   |
| arch    | /           | -ro | chester:/usr/arch \           |
|         | /bsd        | -ro | chester:/usr/arch/bsd \       |
|         | /standards  | -ro | chester:/usr/arch/standards \ |
|         | /dec/uws    | -ro | chester:/usr/arch/dec/uws \   |
|         | /dec/ultrix | -ro | chester:/usr/arch/dec/ultrix  |

---

#### Example A-7: Multiple Mounts, Shared Mounts, and Replicated File Systems in an Indirect Map

---

|         |             |     |                               |
|---------|-------------|-----|-------------------------------|
| mytmp   |             |     | june:/usr/staff/jones:tmp     |
| mynotes |             |     | june:/usr/staff/jones:notes   |
| arch    | /           | -ro | chester:/usr/arch \           |
|         | /bsd        | -ro | chester:/usr/arch/bsd \       |
|         |             |     | bazel:/src/bsd \              |
|         | /standards  | -ro | chester:/usr/arch/standards \ |
|         | /dec/uws    | -ro | chester:/usr/arch/dec/uws \   |
|         |             |     | fiesta:/archive/uws\          |
|         | /dec/ultrix | -ro | chester:/usr/arch/dec/ultrix  |

---

The `-hosts` map is a built-in map supplied by Automount and AutoFS. This map allows a client to access directories that are exported from any host in its `hosts` database. The location of the `hosts` database that your system uses is determined by the services running on your system (DNS, NIS, local) and how those services are specified in the `/etc/svc.conf` file. References to a particular host name result in all of the file systems that are exported from that host being mounted on the local system. For example, the following command results in all of the file systems that are exported from `host1` being mounted on the local system:

```
# cd /net/host1
```

The `/etc/auto.home` map shown in Figure A-1 is an indirect map that allows users to remotely mount their home directories. It can be rewritten using the ampersand (&) and asterisk (\*) substitution characters.

The following example shows how the `/etc/auto.home` map in Figure A-1 can be rewritten using ampersands (&):

```
user1 host1:/usr/staff/&
user2 host2:/usr/staff/&
user3 host2:/usr/staff/&
user4 host2:/usr/staff/&
user5 host3:/usr/staff/&
```

## A.1 Substitution and Pattern Matching

Both the `automount` and `autofs` commands recognize the following substitution characters, allowing you to eliminate redundancy within maps:

- The ampersand (&) can be used in both direct and indirect maps; however, it is most efficient and easily understood when used in indirect maps.
- The asterisk (\*) can be used in indirect maps only.

Because the ampersand and asterisk are most easily used in indirect maps, this section discusses them in the context of indirect maps only. Recall that lines in indirect maps have the following syntax:

```
key          mount-options      location
```

Whenever the `automount` or `autofs` commands encounter an ampersand (&) in a line of an indirect map, they substitute the key in that line for the ampersand (&).

The following example is an indirect map that does not use ampersands:

```
#key          mount-options      location
#
host1         -rw,nosuid         host1:/home/host1
host2         -rw,nosuid         host2:/home/host2
```

Using the ampersand (&) as a substitution character, the entries read as follows:

```
#key          mount-options      location
#
host1         -rw,nosuid         &:/home/&
host2         -rw,nosuid         &:/home/&
```

You can use the asterisk (\*) to substitute for lines that are all formatted similarly. Both daemons use the asterisk to match any host not listed as a

key in an entry before the asterisk. The following example shows how the asterisk (\*) is typically used:

```
#key          mount-options      location
#
host1         -rw,nosuid         &:/home/&
host2         -rw,nosuid         &:/home/&
*             -rw,nosuid         &:/home/&
```

Suppose a user enters the following command:

```
% ls /home/host5
```

Either daemon recognizes the host name, `host5`, as the `key` and substitutes `host5` for each of the ampersands in the `location` field. The map is interpreted as follows for `host5`:

```
#key          mount-options      location
#
host5         -rw,nosuid         host5:/home/host5
```

---

**Note**

---

The `automount` and `autofs` commands ignore any entry that follows an asterisk.

---

## A.2 Environment Variables

You can use the value of an environment variable in a map by adding a dollar sign (\$) prefix to its name. You also can use braces ({} ) to delimit the name of the variable from appended letters or digits.

Environment variables can be inherited from the environment or can be defined explicitly with the `-D` option on the command line. For example, you can invoke the `automount` daemon with the `HOST` variable by entering the following command:

```
# automount -D HOST=hostname
```

To define the same variable for the `autofs` daemon, enter the following command:

```
# autofs -D HOST=hostname
```

The following is an example of a direct map entry that uses the environment variable `HOST` to define subnetworks:

```
/mydir      -rw      server:/export/$HOST
```

## A.3 Mounting File Systems

Automount and AutoFS provide several ways to mount remote directories and file systems:

- Multiple mounts
- Shared mounts
- Replicated file systems

### A.3.1 Multiple Mounts

When you write direct and indirect maps, you can specify that different directories within a file system hierarchy be mounted from different servers. For example, if you mount the `/usr/local` file system on your machine, you can mount the various subdirectories within `/usr/local` from different servers.

The following example shows an entry in a direct map in which the directories `/usr/local/bin`, `/usr/local/src`, and `/usr/local/tools` are mounted from the machines `host1`, `host2`, and `host3`, respectively:

```
/usr/local\  
    /bin    -ro      host1:/usr/local/bin \  
    /src    -ro      host2:/usr/local/src \  
    /tools  -ro      host3:/usr/local/tools
```

This is a direct map because the key, `/usr/local`, is an absolute pathname. If this were an entry in an indirect map, the key would be a simple pathname, such as `local`. The key, `/usr/local`, comprises three subdirectories, each of which is a mount point for a remote directory on a different remote server. The example shows the entry split into four lines with the continuation lines indented for readability.

The preceding example shows multiple, nonhierarchical mounts under `/usr/local`. The following example shows a true hierarchical entry:

```
/usr/local \  
    /          -ro      host0:/usr/local \  
    /bin       -ro      host1:/usr/local/bin \  
    /src       -ro      host2:/usr/local/src \  
    /tools     -ro      host3:/usr/local/tools
```

The mount points used here for the hierarchy are `/`, `/bin`, `/src`, and `/tools`. Note that these mount points are relative to `/usr/local`. The mount point `/` mounts `/usr/local` from `host0`.

When file systems are mounted hierarchically, the entire hierarchy is treated as one object. Each file system is mounted on a subdirectory within another file system, and when a subdirectory within the hierarchy is referenced,

the daemon mounts the entire hierarchy. The entire hierarchy is also unmounted as one object. The only exception is specific to AutoFS.

Like the automount daemon, the `autofs` daemon creates symbolic links for file systems that are served locally. But if the `autofs` daemon encounters an entry in a list of hierarchical file systems that is served locally and would result in a circular symbolic link on the local system (for example, a link from the `/usr/local/bin` directory back to itself), the group semantic is lost. AutoFS will mount and unmount the file systems on an individual basis.

This happens because AutoFS is designed to mount a remote file system on (or create a symbolic link to) the designated mount point itself. It does not, as Automount does, create an additional symbolic link back to a special `/tmp_mnt` directory from which the remote file system is actually served.

### A.3.2 Shared Mounts

When multiple directories within the same remote directory are mounted, the `location` field can be specified as follows:

```
host:path:subdir
```

---

#### Note

---

AutoFS does not support this syntax. If the `autofs` command encounters this syntax, it converts the final colon (`:`) to a slash (`/`) and treats the entry as a typical AutoFS mount.

---

The `host` field is the remote host from which to mount the file system. The `path` field is the pathname of the directory to mount, and the `subdir` field, if specified, is the name of the subdirectory to which the symbolic link is made. This prevents duplicate mounts of the same remote file system when multiple subdirectories within it are accessed.

Suppose an indirect map called `/auto.myindirect` is specified in a master file as follows:

```
/mydir          /auto.myindirect
```

And the `/auto.myindirect` map consists of the following entries:

```
mybin           host1:/usr/staff/diane:bin
mystuff        host1:/usr/staff/diane:stuff
```

When a user accesses a file in `/mydir/mybin`, the automount daemon mounts `host1:/usr/staff/diane`, but creates a symbolic link called `/mydir/mybin` to the `bin` subdirectory in the temporarily mounted file system. If a user immediately tries to access a file in `/mydir/mystuff`, the automount daemon needs only to create a symbolic link that points to the

stuff subdirectory because the `/usr/staff/diane` directory is already mounted. With the following map, the daemon would perform two separate mount operations:

```
mybin          host1:/usr/staff/diane/bin
mystuff        host1:/usr/staff/diane/stuff
```

### A.3.3 Replicated File Systems

You can specify multiple locations for a single mount. If a file system is located on several servers and one of the servers is disabled, the file system can be mounted from one of the other servers. This makes sense only when mounting a read-only file system.

In the following example, the reference pages can be mounted from `host1`, `machine2`, or `system3`:

```
/usr/man\
      -ro,soft      host1:/usr/man \
                    machine2:/usr/man \
                    system3:/usr/man
```

The preceding example can also be expressed as a list of servers, separated by commas and followed by a colon and the pathname, for example:

```
/usr/man -ro,soft host1,machine2,system3:/usr/man
```

This syntax is valid only if the pathname is the same on each server.

When you access the reference pages, the `automount` daemon issues a ping request (NFS v2 loop request) to each of the specified servers concurrently and selects the first server that responds to serve the file system.

In contrast, the `autofs` daemon first classifies each of the specified servers based on the proximity of its network address to the current system (Local, Same Subnet, Same Network, or Other Network). The daemon then attempts to serve the file system from the closest resource, starting with Local addresses.

If the file system can be served locally, the daemon uses a symbolic link to access it. If the file system cannot be served locally, the daemon resorts to trying all Same Subnet, Same Network, and Other Network addresses, in that order. Except when checking Local addresses, the system issues a ping request to each server concurrently and selects the first server that responds to serve the file system.





# B

---

## NIS ypservers Update Scripts

This appendix provides the following scripts for updating the `ypservers` map:

- `addypserver` — Adds a slave server
- `rmyppserver` — Removes a slave server

### B.1 Add Slave Server Script

Use the following procedure to create the `addypserver` script on an NIS master server:

1. Create an `addypserver` file in the `/var/yp` directory and insert the following lines. Where `method` appears, specify the format in which the map is to be stored:

```
#!/bin/sh
PATH="/usr/bin:/var/yp:$PATH"
if [ $# != 1 ]; then
    echo "usage: $0 server"; exit 1
fi
DOMAIN=`/usr/sbin/rcmgr get NIS_DOMAIN`
cd /var/yp
echo "
Adding $1 to ypservers map for domain DOMAIN ..."
(/var/yp/makedbm -u $DOMAIN/ypservers;\
echo $1 $1) | /var/yp/makedbm -a method tmpmap
mv tmpmap.dir $DOMAIN/ypservers.dir
mv tmpmap.pag $DOMAIN/ypservers.pag
yppush ypservers
```

2. Set the permissions to 700, using the `chmod` command as follows:

```
# chmod 700 /var/yp/addypserver
```

To add `host1` to the `ypservers` map, enter the following command:

```
# /var/yp/addypserver host1
```

You still need to edit the NIS master server's master `hosts` file and add an entry for the slave server, if it is not already in the `hosts` file. Then, update and distribute the map by entering the `make` command. See Section 3.4.1 for more information.

## B.2 Remove Slave Server Script

Use the following procedure to create the `rmypserver` script on an NIS master server:

1. Create a `rmypserver` file in the `/var/yp` directory and insert the following lines. Where *method* appears, specify the format in which the map is to be stored:

```
#!/bin/sh
PATH="/usr/bin:/var/yp:$PATH"
if [ $# != 1 ]; then
    echo "usage: $0 server"; exit 1
fi
DOMAIN=`/usr/sbin/rcmgr get NIS_DOMAIN`
cd /var/yp
echo "
Removing $1 from ypservers map for domain DOMAIN ..."
/var/yp/makedbm -u $DOMAIN/ypservers | grep -v $1 \
| /var/yp/makedbm -a method tmpmap
mv tmpmap.dir $DOMAIN/ypservers.dir
mv tmpmap.pag $DOMAIN/ypservers.pag
yppush ypservers
```

2. Set the permissions to 700, using the `chmod` command as follows:

```
# chmod 700 /var/yp/rmypserver
```

To remove `host1` from the `ypservers` map, enter the following command:

```
# /var/yp/rmypserver host1
```

# C

---

## NFS Error Messages

You might see the following types of NFS error messages:

- Server error messages (Section C.1)
- Client error messages (Section C.2)

### C.1 Server Error Messages

The following error messages are issued to the screen or console or sent to the syslogd daemon.

```
authget: unknown authflavor n  
authflavor
```

**Explanation:** Each NFS request has an authentication type. This message is displayed if the type is not AUTH\_UNIX.

**User Action:** Have the client application use the AUTH\_UNIX authentication type.

```
fh3tovp: bad length: n
```

**Explanation:** A client sent a bad file handle to the server.

```
NFS request from unprivileged port, source IP address = n
```

**Explanation:** The server, performing NFS server port monitoring, received an NFS request from a nonprivileged port (greater than or equal to 1024) on a client. This might indicate a security problem.

```
NFS server: fs(n,n) not mounted; client address = n.n.n.n
```

**Explanation:** The client requested a file on a file system that is not mounted or does not exist on the server. This can occur if a file system is unmounted while clients are using it or if the client passed an invalid file handle.

**User Action:** Make sure that the appropriate file system is mounted on the NFS server. If the file system is mounted on the same device, have the client system retry the operation. If the file system is mounted on a different device, have the client system unmount and remount the remote file system.

NFS server: stale file handle fs(*n,n*) file *file* gen *n*,  
client address = *n.n.n.n* errno *n*

**Explanation:** The client accessed a file that no longer exists. The file was deleted either by the server or by another client.

NFS server: unexported fs(*n,n*) file *file*, client address  
= *n.n.n.n*

**Explanation:** A client that previously had access to a file system can no longer access the file system, either because of changes in the `/etc/exports` file or in the `net` group mapping.

**User Action:** Have the client system unmount the file system.

rfs\_dispatch botch

**Explanation:** The duplicate request cache routine returned an illegal value.

rfs\_dispatch: bad rfs reply *n*  
ret

**Explanation:** A server routine did not return a value or returned an incorrect value.

rfs\_dispatch: dispatch error, no reply  
rfs\_dispatch: sendreply failed

**Explanation:** Possible reasons for this message include the following:

- The server is out of memory and cannot process or reply to a request.
- The server cannot find a route to the source.
- There is some other network-related problem.

too many nfsds

**Explanation:** There are more `nfsd` daemons registered with NFS than were started.

## C.2 Client Error Messages

This appendix provides an explanation and suggested user actions for the following classes of client error messages:

- Remote mount error messages
- Automount error messages
- AutoFS error messages
- Console error messages

Within each section, error messages are listed alphabetically.

## C.2.1 Remote Mount Error Messages

The following error messages are displayed if you are mounting directories or file systems from remote systems:

```
mount: unknown special file or file system xxx
```

**Explanation:** There is no entry in the `/etc/fstab` file for the mount point that you specified in the `mount` command line.

**User Action:** Verify that there is an entry in the `/etc/fstab` file for the file system. If not, add an entry. If one exists, look for syntax errors or typos in the entry. See `fstab(4)`.

```
/etc/fstab: No such file or directory
```

**Explanation:** The `/etc/fstab` file does not exist. The `mount` command discovered this when it tried to look up the name specified on the command line.

**User Action:** Create an `/etc/fstab` file and include the appropriate entries. See `fstab(4)`.

```
nfs_mount: Permission denied for yyy
```

**Explanation:** Your host name is not in the export list for the file system or directory you want to mount from the server.

**User Action:**

1. Get a list of your host's exported file systems and directories by using the `showmount -e` command. For example, enter the following command if your server's host name is `host2`:  

```
# /usr/bin/showmount -e host2
```
2. If the file system or directory you want to mount remotely is not on the list, or if your host or network group name is not on the user list for the file system or directory, log in to the server and look in the `/etc/exports` file for the correct file system entry.
3. If the file system or directory name is in the `/etc/exports` file, but not in the output from `showmount`, the failure is in the `mountd` daemon. The `mountd` daemon could not parse that line in the file, could not find the file system or directory, or the file system or directory name was not a locally mounted file system.

If the file system or directory name is in the `/etc/exports` file and Network Information Service (NIS) is configured, verify

that the `yplibd` daemon is running; it might have stopped. See `exports(4)` for further information.

```
nfs_mount: cannot mount xxx on yyy: Mount device busy
```

**Explanation:** The file system or directory you are trying to mount is already mounted.

```
nfs_mount: cannot mount xxx on yyy: No such file or directory
```

**Explanation:** The local mount point does not exist.

**User Action:** Verify that the mount point exists and that it is spelled correctly.

```
nfs_mount: cannot mount xxx on file: Not a directory
```

**Explanation:** Either the remote file system or the local mount point is not a directory.

**User Action:** Verify that the remote file system and the local mount point are directories (not files) by using the `ls` command. Verify the spelling of both directories.

```
nfs_mount: cannot mount xxx on yyy: Not owner
```

**Explanation:** You must mount the remote file system or directory as superuser (root) on your system.

```
nfs_mount: illegal file system name xxx; use host:pathname
```

**Explanation:** You did not specify the name of the server when you issued the mount command.

**User Action:** For example, to mount the file system `/usr/src` from the server `host2`, enter the following command:

```
# mount host2:/usr/src /host2/usr/src
```

```
nfs_mount: invalid directory name xxx
directory pathname must begin with '/'.
```

**Explanation:** The mount point on the local (client) system must be an absolute path starting at the root directory (`/`).

```
nfs mount: RPC: Authentication error;
why=Client credential too weak
```

**Explanation:** The server is allowing client superuser mounts only and you are not a superuser. See `mountd(8)` for further information.

```
nfs_mount: RPC: Authentication error;
why=Server rejected credential
```

**Explanation:** Possible reasons for this error message include the following:

- The server is running with Internet address verification turned on and it cannot resolve your Internet address. If your system has multiple network interfaces configured, the server must be able to resolve all IP addresses, either using the local `/etc/hosts` file or the distributed `hosts` file.
- The server is running with domain or subdomain verification turned on and your system is not in the same domain or subdomain as the server.

See `mountd(8)` for further information.

```
nfs_mount: xxx server not responding: port mapper failure
rpc_timed out Giving up on yyy
```

**Explanation:** The server you are trying to mount from is down, or its port mapper is inoperative.

**User Action:**

1. Log in remotely to the server. If you are able to log in, the network is working.
2. Execute the `rpcinfo` command from the server. For example, for a server named `host2`, you would enter the following command:

```
# /usr/sbin/rpcinfo -p host2
```

If the port mapper is running properly on the server, the `rpcinfo` command lists the registered program numbers. If it does not, restart the port mapper on the server. You also need a port mapper running on the client host; if it is not running there, start it. See `portmap(8)` for more information.

3. After you restart the port mapper, stop the NFS daemons by entering the following command:

```
# /sbin/init.d/nfs stop
```

If NIS is running, stop the `ypbind` daemon on the server. Use the `ps` command to obtain the process ID (PID) and the `kill` command to stop the process:

```
# ps -A | grep ypbind
  439 ??      I          0:00.02 /usr/sbin/ypbind ...
170866 pts/3  S +       0:00.01 grep ypbind
# kill -9 439
```

4. If you stopped the `yplibind` daemon, restart it by entering the following command:

```
# /usr/sbin/yplibind &
```

Restart the NFS daemons on the server by entering the following command:

```
# /sbin/init.d/nfs start
```

```
nfs_mount: xxx server not responding: rpc prog not registered
```

**Explanation:** The `mount` command got through to the port mapper, but the NFS `mountd` daemon was not registered.

**User Action:**

1. Log in to the server.
2. Verify that the `/usr/sbin/mountd` file exists by using the `ls` command.
3. Run the `ps` command to see if the `mountd` daemon is running. If it is not running, restart it by entering the following command:

```
# /usr/sbin/mountd
```

```
Can't get net id for host
```

**Explanation:** There is no entry in the `/etc/hosts` file for the NFS server specified in the `mount` command line. If NIS is running, there is no entry in the `hosts` NIS map for the host name specified. If BIND is running, there is no entry in the `hosts` database for the host name specified.

## C.2.2 Automount Error Messages

The following error messages are issued to the screen or console or sent to the `syslogd` daemon by the `automount` program:

```
bad entry in map mapname
```

**Explanation:** The map entry in *mapname* is malformed and the `automount` program cannot interpret it.

**User Action:** Verify the entry; you might need to include escape characters.

```
Can't mount mountpoint: reason
```

**Explanation:** The `automount` program cannot mount itself at *mountpoint*. The error is indicated in the *reason* statement.



couldn't create directory: *reason*

**Explanation:** The automount program could not create a directory. The error is indicated in the *reason* statement.

dir *mountpoint* must start with '/'

**Explanation:** The *mountpoint* must have a full pathname.

**User Action:** Verify both the spelling and path name of the mount point.

hierarchical mountpoint: *mountpoint*

**Explanation:** The automount program will not allow itself to be mounted within an automounted directory.

**User Action:** Use another strategy to mount the directory.

host *hostname* not responding

**Explanation:** The automount program attempted to mount from *hostname* but received no response or failed. These errors could indicate a server or network problem.

*hostname:filesystem* server not responding

**Explanation:** The automount program attempted to mount from *hostname* but received no response or failed. These errors could indicate a server or network problem.

*hostname: exports: rpc\_err*

**Explanation:** The automount program encountered an error while attempting to get the list of exported file systems and directories that it is allowed to mount from *hostname*.

This error occurs when a user attempts to access a mount point that has the `-hosts` map associated with it. This error indicates a server or network problem.

*hostname:filesystem* already mounted on *mountpoint*

**Explanation:** The automount program is attempting to mount a file system on a mount point that has already been mounted with that file system.

map *mapname*, key *key*: bad

**Explanation:** The map entry in *mapname* is malformed and the automount program cannot interpret it.

**User Action:** Verify the entry; you might need to include escape characters.

*mapname:* Not found

**Explanation:** The automount program cannot locate the map it requires. This message is returned only when you specify the `-v` option.

*mapname:* *yp\_err*

**Explanation:** The automount program encountered an error when looking up an NIS map entry.

Mount of *hostname:filesystem* on *mountpoint:* *reason*

**Explanation:** The automount program attempted to mount from *hostname* but received no response or failed. These errors could indicate a server or network problem.

*mountpoint:* Not a directory

**Explanation:** The *mountpoint* exists but is not a directory.

**User Action:** Verify both the spelling and pathname of the mount point.

*mountpoint-pathname* from *hostname:* absolute symbolic link

**Explanation:** The automount program detected that *mountpoint* is an absolute symbolic link (begins with `/`). The content of the link is *pathname*. Because this might have undesired consequences on the client, the automount program will not mount on absolute symbolic links.

no mount maps specified

**Explanation:** The automount program cannot find any maps to serve, nor can it find any NIS maps. This message is returned only when you specify the `-v` option.

WARNING: *hostname:file system* already mounted on *mountpoint*

**Explanation:** The automount program is mounting itself on top of an existing mount point. This message is a warning only.

WARNING: *mountpoint* not empty!

**Explanation:** The *mountpoint* directory is not empty. This message is returned only when you specify the `-v` option. It is warning you that the previous contents of *mountpoint* will not be accessible while the mount is in effect.

The following error messages can occur when a file system is exported from multiple servers as specified in a multiple-server map entry. They indicate possible network problems that can occur when the automount daemon requests a response from the servers.

Cannot create socket for broadcast rpc: *rpc\_err*

**Explanation:** No server in a multiple-server map entry is responding. This indicates that the replicated file system could not be reached on any of the specified servers.

Cannot receive reply to many\_cast: *rpc\_err*

**Explanation:** No server in a multiple-server map entry is responding. This indicates that the replicated file system could not be reached on any of the specified servers.

Cannot send broadcast packet: *rpc\_err*

**Explanation:** No server in a multiple-server map entry is responding. This indicates that the replicated file system could not be reached on any of the specified servers.

Many\_cast select problem: *rpc\_err*

**Explanation:** No server in a multiple-server map entry is responding. This indicates that the replicated file system could not be reached on any of the specified servers.

NFS server (pid *n@mountpoint*)not responding still trying

**Explanation:** An NFS request to the automount daemon with PID *n* serving mount point has timed out. The automount daemon might be overloaded or not running.

**User Action:** If the condition persists, reboot the client. You can also do the following:

1. Exit all processes that are using automounted directories.
2. Kill the current automount process.
3. Restart the automount process from the command line.

Remount *hostname:filesystem* on *mountpoint* server not responding

**Explanation:** The automount program was attempting to remount *filesystem* because it discovered that a part of the automounted hierarchy at the *mountpoint* was busy. The remote file system's server, *hostname*, did not respond to the mount request. This error indicates a server problem.

trymany: servers not responding: *reason*

**Explanation:** No server in a multiple-server map entry is responding. This indicates that the replicated file system could not be reached on any of the specified servers.

### C.2.3 AutoFS Error Messages

The following sections describe error messages for the two components of AutoFS: the `autofs` daemon and the `autofsmount` command.

#### C.2.3.1 `autofs` Messages

The following error messages are issued to the screen or console or sent to the `syslogd` daemon by the `autofs` program:

`autofs not configured`

**Explanation:** AutoFS is not properly configured in the kernel.

**User Action:** If necessary, add the `AUTOFS` option to the kernel configuration file and rebuild the kernel. See *System Administration* for more information on modifying and rebuilding the kernel.

`Cannot create socket for nfs: reason`

**Explanation:** Network socket creation failed due to *reason*.

`can't mount hostname`

**Explanation:** A mount request was rejected by the `mountd` daemon on *hostname*. This error usually indicates a permissions problem or that the file system does not exist.

**User Action:** Verify the export permissions in the `/etc/exports` file on the server and verify that the file system exists.

`Can't ping mountd version NFS-version at server hostname  
reason`

**Explanation:** The `autofs` daemon attempted to communicate with the `mountd` daemon on the *hostname* server, but received no response.

**User Action:** Verify the status of the network and verify that the server is properly configured and running NFS services.

`cfg_subsys_state returned errorcode`

**Explanation:** AutoFS is not properly configured in the kernel.

**User Action:** If necessary, add the `AUTOFS` option to the kernel configuration file and rebuild the kernel. See *System Administration* for more information on modifying and rebuilding the kernel.

host *hostname* not responding

**Explanation:** The `autofs` daemon attempted to mount from *hostname* but it received no response or the request failed. These errors could indicate a server or network problem.

**User Action:** Verify the status of the network and verify that the server is properly configured and running NFS services.

*hostname* exports: `rpc_err`

**Explanation:** The `autofs` daemon encountered an error while attempting to get the list of exported file systems and directories that is allowed to mount from *hostname*. This occurs during attempted access to a mount point with the `-hosts` map. It indicates a server or network problem.

**User Action:** Verify the status of the network and verify that the server is properly configured and running NFS services.

*hostname*: `mountd` not responding *reason*

**Explanation:** The `autofs` daemon attempted to communicate with the `mountd` daemon on the *hostname* server, but received no response.

**User Action:** Verify the status of the network and verify that the server is properly configured and running NFS services.

*hostname*: `server's portmap` not responding

**Explanation:** The `autofs` daemon attempted to communicate with the `portmap` daemon on the *hostname* server, but received no response.

**User Action:** Verify the status of the network and verify that the server is properly configured and running NFS services.

lookup\_addr: `gethostbyname` failed *error* for *hostname*

**Explanation:** The `autofs` daemon was unable to obtain a network address for the named host.

**User Action:** Verify the address for the host in the local hosts file and the DNS or NIS database. Verify that the DNS or NIS server is up and running.

match *mapname:keyname* failed: *reason*

**Explanation:** The `autofs` daemon is having a problem reading the map file *mapname* to find key *keyname*. The error is indicated in the *reason* statement.

Mount of *hostname:filesystem* on *mountpoint*: *reason*

**Explanation:** The `autofs` daemon attempted to mount from *hostname*, but it received no response or the request failed. These errors could indicate a server or network problem.

**User Action:** Verify the status of the network and verify that the server is properly configured and running NFS services.

Unable to locally serve *filesystem*

**Explanation:** Locally serving the file system would result in a circular symbolic link.

**User Action:** Choose a different mount point for the file system, or specify a different host to serve the file system.

### C.2.3.2 autofs mount Messages

`autofs` is not configured or not enabled

**Explanation:** AutoFS is not properly configured in the kernel.

**User Action:** If necessary, add the `AUTOFS` option to the kernel configuration file and rebuild the kernel. See *System Administration* for more information on modifying and rebuilding the kernel.

Intercept *filesystem* mount failed: *reason*

**Explanation:** The attempt to create an intercept mount point for *filesystem* has failed due to *reason*. The `autofs` command issues this error message for direct map entries, and when running in verbose mode, for indirect map entries as well.

Map *mapname* does not exist

**Explanation:** The `autofs` command could not find the specified direct or indirect map file.

**User Action:** Ensure that you have specified the proper location for the map files on the command line or in your master map file.

Note: Indirect entry in map *mapname* with key *keyname* cannot be locally served with the `mounton` and `mountfrom` directories as defined.

**Explanation:** An external server will be chosen to avoid a circular symbolic link.

Note: The hierarchical entry in map *mapname* for *keyname* cannot be served locally

**Explanation:** An external server will be chosen to avoid a circular symbolic link.

Note: The shared map entry in map *mapname* with key *keyname* will be converted to a non-shared entry

**Explanation:** AutoFS does not support the shared mount syntax of Automount. It converts all shared map entries to their nonshared counterparts.

Unmount *filesystem*: *reason*

**Explanation:** An attempt to unmount *filesystem* has failed with *reason*.

Warning: Cannot support the hierarchy in map *mapname* with key *keyname* with the *mounton* and *mountfrom* directories as defined.

**Explanation:** The hierarchical direct map entry for subdirectory / cannot be supported, as no external servers are listed and locally serving it would create a circular symbolic link. The file systems in the map entry will be treated as though they are individual map entries.

**User Action:** Specify an external server or change the key and/or the location of the file system in question to avoid a circular symbolic link.

Warning: Skipping entry in map *mapname* with key *keyname*

**Explanation:** The file system will be locally served. No intercept mount point will be created, only a symbolic link.

Warning: The hierarchical entry in map *mapname* for *keyname* will not work.

**Explanation:** A hierarchical direct map entry for some subdirectory other than / cannot be supported, as no external servers are listed and locally serving it would create a circular symbolic link. The file systems in the map entry will be treated as though they are individual map entries.

**User Action:** Specify an external server or change the key and/or the location of the file system in question to avoid a circular symbolic link.

Warning: There are no servers available for this entry

**Explanation:** In the context of previous messages for this map entry, this error message indicates that locally serving the file system would create a circular symbolic link, and no external servers are specified.

**User Action:** Specify an external server or change the key and/or the location of the file system in question to avoid a circular symbolic link.

## C.2.4 Console Error Messages

The following error messages might be displayed on the NFS client system console and in the error logger. They note an NFS file access failure.

NFS server *hostname* not responding, still trying

**Explanation:** File operations in a hard-mounted file system are suspended because communication between the client and the server has stopped.

NFS server *hostname* ok

**Explanation:** File operations have resumed.

NFS *file operation* failed for server *hostname*: *reason*

**Explanation:** If the operation is in a soft-mounted file system and the server is inoperable, the reason for the failure is that the operation timed out.

NFS write error, server *hostname*, remote file system full

**Explanation:** A write operation failed because the remote file system is full.

NFS write error *errno*, server *hostname*, fs(*n*,*n*), file *file*

**Explanation:** A write operation was refused by the server. The *fs* and *file* variables are parts of the file handle (fhandle). See `errno(2)` for a description of write errors.



# D

---

## uucp Messages

This appendix provides a description and suggested user actions for the following uucp messages:

- Status and log file messages (Section D.1)
- tip error messages (Section D.2)

### D.1 Status and Log File Messages

The messages in this section might appear in uucp status or log files. Use the `uulog` or `uustat` command to see the status messages.

ASSERT ERROR

An ASSERT error occurred, indicating a condition that only a system manager can solve. ASSERT errors are stored in the `/usr/spool/uucp/.Admin/errors` file and have the following form:

```
ASSERT ERROR (prog)pid: xxxx (date/time) error error-location
```

The variables have the following meaning:

|                       |   |
|-----------------------|---|
| <i>prog</i>           | Name of the program generating the error.   |
| <i>xxxx</i>           | Process ID (PID) of the program.  |
| <i>date/time</i>      | Data and time when the error occurred.  |
| <i>error</i>          | A message describing the error. The message might include arguments. If there is a value contained in parentheses following the message, this value is often the error number ( <code>errno</code> ). |
| <i>error-location</i> | Name and version of the source file and the line in the file where the error occurred.  |

Table D–1 lists the ASSERT error messages.

**Table D-1: ASSERT Error Messages**

| <b>Error Message</b>  | <b>Explanation and User Action</b>  |
|---|---|
| BAD LINE <i>line</i> ( <i>num</i> )                                   | <p>The <code>/usr/lib/uucp/Devices</code> file has a bad line: <i>line</i> is the bad line and <i>num</i> is the number of fields found in the line.</p> <p>Correct the entry in the file. See <code>Devices(4)</code> for information on the file entries.</p>   |
| BAD LOGIN_UID (-1)<br>BAD UID (-1)<br>CAN NOT FIND UID ( <i>num</i> ) | <p>The user ID used by the process is not currently logged in and is not defined in the <code>/etc/passwd</code> file or the networks database, if using NIS.</p> <p>Check your user ID by using the <code>id</code> command, and change the entry in the <code>/etc/passwd</code> file or the networks database, if using NIS.</p> |
| BAD SPEED ( <i>num</i> )  | <p>An unsupported baud rate (<i>num</i>) was specified.</p> <p>Check the command arguments or <code>uucp</code> configuration files. Then run <code>uucpsetup</code> to change the baud rate.</p>   |
| CAN'T CHDIR <i>dir</i> ( <i>num</i> )                                 | <p>A command to change to directory <i>dir</i> failed with errno <i>num</i>. The <code>uucp</code> program required read access to the directory.</p> <p>Check the permissions on the directory. If the directory does not exist, check the permissions on the spool directory.</p>   |
| CAN'T CLOSE file ( <i>num</i> )                                       | <p>Could not close file with errno <i>num</i>.</p>  |
| CAN'T CREATE file ( <i>num</i> )                                      | <p>Could not open file with errno <i>num</i>. The <code>uucp</code> program needs write access to the file or directory.</p> <p>Check the permissions on the file and directory.</p>  |
| CAN'T LINK file ( <i>num</i> )  | <p>Could not link a source file to the work file <i>file</i> in the <code>uucp</code> spool directory with errno <i>num</i>.</p> <p>Check the spool directory permissions.</p>  |
| CAN'T LOCK LCK.SQ. <i>sys</i> (0)                                     | <p>Could not lock the <code>/var/spool/locks/LCK.SQ.<i>sys</i></code> file for system <i>sys</i>.</p> <p>Check the time and permissions on the file. If it is old, delete the file.</p>   |

**Table D-1: ASSERT Error Messages (cont.)**

| <b>Error Message</b>             | <b>Explanation and User Action</b>  |
|----------------------------------|---|
| CAN'T OPEN file ( <i>num</i> )   | <p>Could not open file with errno <i>num</i>. The uucp program needs write access to the file or directory.</p> <p>Check the permissions on the file and directory.</p>   |
| CAN'T STAT file ( <i>num</i> )   | <p>The uucico daemon could not obtain information about the file with errno <i>num</i>.</p> <p>Check the permissions on the file.</p>   |
| CAN'T UNLINK file ( <i>num</i> ) | <p>Could not unlink the file with errno <i>num</i>.</p> <p>Check the permissions on the file.</p>   |
| CAN'T WRITE file ( <i>num</i> )  | <p>Could not open the file with errno <i>num</i>. The uucp program needs write access to the file or directory.</p> <p>Check the permissions on the file and directory.</p>   |
| FILE EXISTS file ( <i>num</i> )  | <p>The file already exists and an access() call on that file returned errno <i>num</i>. The file is a uucp work file that was not cleaned up by another uucp process.</p>   |
| No uucp server (0)               | <p>The uucp service is not defined in the /etc/services file.</p> <p>Edit the /etc/services file and add a uucp entry.</p>  |
| SYSLST OVERFLOW ( <i>num</i> )   | <p>There are too many jobs queued for a single system. The number of jobs is <i>num</i>.</p> <p>Use the uustat -q command and examine the queue. If the jobs are not old, try the request again. If there are old jobs in the queue, use the uucleanup command to clean out the queue. See uucleanup(8) for more information.</p> |
| TOO MANY LOCKS ( <i>num</i> )    | <p>The system limit on the number of lock files was exceeded while creating lock file <i>num</i>.</p> <p>Retry the request after the the current activity is completed.</p>   |

**Table D-1: ASSERT Error Messages (cont.)**

| <b>Error Message</b>          | <b>Explanation and User Action</b>   |
|-------------------------------|--|
| XMV ERROR file ( <i>num</i> ) | <p>The <code>uuxqt</code> daemon could not move the execute file to the <code>.Xqtdir</code> directory in the <code>uucp</code> spool area and failed with errno <i>num</i>.</p> <p>Use the <code>ls -l</code> command and verify that the <code>.Xqtdir</code> directory is owned by <code>uucp</code> and has a <code>775</code> permission.</p> |

**BAD LOGIN/MACHINE COMBINATION**

**Explanation:** There are two possible reasons for this message:

- The `VALIDATE` option for the local system is set in the Permissions file on the remote system and the local system's user name does not match the `LOGNAME` entry for the system in the remote system's Permissions file.
- The local system's user name has no corresponding `LOGNAME` entry in the remote system's Permissions file.

**User Action:** Either ask the remote system administrator to add a `LOGNAME` entry for that user name, or edit the `Systems` file and modify the entry for the remote system to use a known user name.

**BAD SEQUENCE CHECK**

**Explanation:** The information in `/usr/lib/uucp/SQFILE` file on the local and remote system is inconsistent. Possible reasons include:

- A new `SQFILE` has been installed on either system, possibly because a new operating system release was installed.

**User Action:** Synchronize the local and remote files.

- Another system is imitating either the local or remote system. This indicates a potential security problem.

**User Action:** Verify that both systems are legitimate and report security issues, as necessary.

**CALLBACK REQUIRED**

**Explanation:** The local system initiated a call and informed the remote system that it has work for that system. The remote system is configured to accept work only if it initiates a call to the local system. Work is queued until the remote system calls the local system.

**User Action:** Monitor the queue to verify that all jobs are completed.

CALLER SCRIPT FAILED

**Explanation:** An error occurred while processing the chat script, defined in the `Systems` file.

**User Action:** Enter the `uutry remote_system` command and observe the prompts from the remote system. Compare the prompts to the chat script. If there is a difference, run the `uucpsetup` script and change the chat script.

CAN'T ACCESS DEVICE

**Explanation:** Possible reasons include:

- The physical device could not be opened.

**User Action:** Check the permissions on the terminal (tty) line, using the `ls -l` command. If neither user `uucp` nor group `uucp` has write access to the line, change the mode to `666`.

- The modem type is not defined in the `/usr/lib/uucp/Dialers` file.

**User Action:** Verify that the modem type has an entry in the `Dialers` file. If not, run the `uucpsetup` script and make an entry for the modem type.

CANNOT OPEN SYSTEMS FILE FOR READ

**Explanation:** The `uucp` program cannot read the `/usr/lib/uucp/systems` file.

**User Action:** Change the mode to `650`, and the owner and group to `uucp`.

CONN FAILED (*string*)

**Explanation:** The connection to the remote system failed; *string* describes the reason for the failure. The system will reconnect as necessary.

**User Action:** Monitor the queue to verify that all jobs are completed. If the problem persists, check your configuration.

CONVERSATION FAILED

**Explanation:** The conversation with the remote system has abnormally ended. Possible reasons are a modem error or system crash. Partially completed jobs are requeued and processed later.

**User Action:** Monitor the queue to verify that all jobs are completed.

DEVICE LOCKED

**Explanation:** Another utility (`tip`, `cu`, `uugetty`, or `uucico`) is already using the device.

**User Action:** Retry the request; you will continue to receive this message until the other utility has finished using the device.

DIAL FAILED

**Explanation:** The modem dialing sequence failed or timed out.

**User Action:** Retry the command.

LOGIN FAILED

**Explanation:** The `uucico` daemon timed out while trying to log in to the remote system.

**User Action:** Use the `uutry` command with your request to determine why the login is failing.

If the error occurs while processing the chat script, run the `uucpsetup` script and modify the chat script to reflect the actual messages used by the remote system. For example, if the chat script stops while waiting for a login prompt, modify the chat script to send a carriage return and delay before getting a login prompt.

If the login to the remote system is successful and then an error occurs, the `uucico` daemon on the remote system failed to start or was slow in sending the `Shere` message to the local system.

LOST LINE (LOGIN)

**Explanation:** The connection was lost during the login process.

**User Action:** Retry the request.

NO DEVICES AVAILABLE

**Explanation:** There are no devices available on this system of the type or speed requested.

**User Action:** You can install additional devices on your system, if your system allows, or modify the request to use one of the available devices in the `/usr/lib/uucp/Devices` file.

REMOTE DOES NOT KNOW ME

**Explanation:** The local system does not have an entry in the remote system's `Systems` file.

**User Action:** Contact the remote system's administrator to have an entry for your system put in the `Systems` file.

REMOTE HAS A LCK FILE FOR ME

**Explanation:** The remote system is trying to contact the local system while the local system is trying to connect to the remote system. The uucp utilities do not allow simultaneous connections between systems.

**User Action:** You can either retry the request later, or wait and see if the queued request is performed when the remote system connects to your system.

REMOTE REJECT AFTER LOGIN

**Explanation:** After successfully logging in to the remote system, the local and remote systems could not start a conversation. The remote system also returns the message BAD LOGIN/MACHINE COMBINATION.

**User Action:** Check the configuration for the connection on both systems.

REMOTE REJECT, UNKNOWN MESSAGE

**Explanation:** The remote system rejected the connection to the local system, but did not return a recognizable error message.

**User Action:** Retry your operation.

STARTUP FAILED

**Explanation:** After successfully logging in to the remote system, the local and remote systems could not start a conversation. Either the systems could not agree on a protocol or they could not start the protocol.

**User Action:** Verify that both the local and remote systems specify the same protocol in the `/usr/lib/uucp/Systems` file.

SUCCESSFUL

**Explanation:** The conversation completed successfully.

SYSTEM NOT IN Systems FILE

**Explanation:** The remote system is not in the `/usr/lib/uucp/Systems` file.

**User Action:** Use the `uname` command to view a list of known uucp systems.

TALKING

**Explanation:** The local system is having a conversation with the remote system.

WRONG MACHINE NAME

**Explanation:** The remote system name does not match the system name entry in the `/usr/lib/uucp/Systems` file.

**User Action:** Verify the system name and run `uucpsetup` to make the necessary changes.

WRONG TIME TO CALL

**Explanation:** The remote system cannot be called at this time. The job is queued for completion later.

**User Action:** If you want to change the time, run `uucpsetup`.

## D.2 tip Error Messages

The following messages might be displayed when using the `tip` utility:

all ports busy

**Explanation:** All ports are in use.

**User Action:** Try your request again later.

can't open log file '/var/log/aculog' for update  
contact your administrator

**Explanation:** The `/var/log/aculog` file does not exist.

**User Action:** Create the file with the mode 664, and owner and group `uucp`.

/etc/phones: can't open phone numbers file

**Explanation:** The `/etc/phones` file does not exist, or the `tip` utility cannot read the `phones` file.

**User Action:** Verify that the `phones` file exists and that it is not corrupted. If necessary, create a new `phones` file. See `phones(4)` for more information.

link down

**Explanation:** The terminal line (`tty`) cannot be opened.

**User Action:** Check that the mode of the `tty` device is 666.

missing phone number

**Explanation:** The remote system's phone number is not in the `/etc/phones` file.



**User Action:** Edit the `/etc/phones` file and add the remote system's phone number.

system\_name: missing device spec

**Explanation:** The terminal line (`dv` parameter) is not defined in the `/etc/remote` file.

**User Action:** Edit the `/etc/remote` file and add the parameter.

tip: unknown host *sysname*

**Explanation:** The remote host system is not in the `/etc/remote` file.

**User Action:** Do one of the following:

- Create an entry for the system in the `/etc/remote` file. See `remote(4)` for more information.
- Invoke `tip` using the remote host system's phone number instead of its name.

tip: can't open host description file

**Explanation:** The `/etc/remote` file does not exist, or the `tip` utility cannot read the remote file.

**User Action:** Verify that the `remote` file exists and that it is not corrupted. If necessary, create a new remote file. See `remote(4)` for more information.

tip: unknown host *tipspeed*

**Explanation:** The `tip` utility is not configured to use the *speed* specified on the command line.

**User Action:** Verify whether the hardware supports the speed. If it can, create a `tipspeed` entry for the speed in the `/etc/remote` file, using other `tipspeed` entries as a model. Create corresponding `UNIX-speed` and `dialspeed` entries in the file. Specify the modem type and the serial port to which it is attached, using the `at` and `dv` fields in the `dialspeed` entry.

Unknown ACU type

**Explanation:** The modem is unsupported.

**User Action:** Check the `at` field for the host system entry in the `/etc/remote` file. If the entry is correct, create an entry for the modem in the `/etc/acucap` file. See `acucap(4)` for more information.

xxx: unknown parity value

**Explanation:** The parity value (pa parameter) in the `/etc/remote` file is invalid.

**User Action:** Edit the `/etc/remote` file and enter a valid value. See `remote(4)` for more information.

# E

---

## sendmail Error Messages

This appendix provides an explanation and suggested user actions for the sendmail error messages. These messages can occur when sending mail to another user on the same host or when sending mail using TCP/IP. If other mailers are configured on your system (for example, DECnet), see the documentation that accompanies the mailer for additional messages.

The following sendmail messages are returned in a rejected mail message or sent to the syslogd daemon:

```
binmail: opening /usr/spool/mail/filename -: Permission
denied
```

**Explanation:** The /bin/mail program could not deliver the mail on the destination host.

**User Action:**

- Verify the permissions on the /usr/spool/mail directory. The correct permissions are 1777.
- Verify the mailbox permissions. The correct permissions are 600.
- Verify that the mailbox owner is correctly specified.

Cannot send message for 3 days

**Explanation:** The message was not delivered during the period specified by the retry parameter in the /var/adm/sendmail/sendmail.cf file. It is being returned to the sender. Possible reasons are as follows:

- The destination host does not exist.
- The mail was addressed to a host outside of your company and no relay host has been configured in the /var/adm/sendmail/sendmail.cf file.
- The host has been off line or the network connection has been unreliable for three days.

**User Action:**

1. Verify all address information.

2. If the mail was addressed to a host outside of your company, you might not be able to send the mail directly. Check your `sendmail` configuration by entering the following command:

```
# grep '^define(_GateINET' /var/adm/sendmail/hostname.m4
```

If the braces in the output are empty (that is, do not contain a host name), reconfigure `sendmail` and specify a relay host. See Section 7.3 for more information on specifying a relay name.

3. Send the message again. The message is queued and sent automatically when the host is reachable.

Connection refused

**Explanation:** The `sendmail` daemon is not running on the destination host.

**User Action:** Check whether `sendmail` is running on the host by using the `ps` command as follows:

```
# ps -ax | grep send
```

If it is not, ask the system administrator to start `sendmail`.

Connection timed out during user open

**Explanation:** A problem occurred during the Simple Mail Transfer Protocol (SMTP) session between 2 hosts, causing a time out.

**User Action:** No user action is necessary; the message will be retried later.

Host unknown

**Explanation:** Possible reasons are as follows:

- An address record for the host was not found.
- The `/var/adm/sendmail/sendmail.cf` file does not define a relay host that can handle mail addresses outside of your company.

**User Action:**

1. If the Domain Name System (DNS) is not configured on your host, verify that the host's address is defined. Check the `/etc/hosts` file if you are resolving addresses locally or issue the `ypmatch hostname hosts` command if you are using the Network Information Service (NIS). The `hosts` entry in the `svc.conf` file defines the services used. If the host is not defined, ask your system administrator to correct the problem.
2. Check for MX records for the host by using the `nslookup` command as follows:

```
# nslookup -q=mx hostname
```

If a record exists, go to step 3.

3. Check for address records by using the `nslookup` command. If the address is not found, have the DNS administrator for the destination domain add an address record for the host in the destination domain's DNS data files.
4. If the mail was addressed to a host outside of your company, you might not be able to send the mail directly. Check your `sendmail` configuration by entering the following command:

```
# grep '^define(_GateINET' /var/adm/sendmail/hostname.m4
```

If the braces in the output are empty (that is, do not contain a host name), reconfigure `sendmail` and specify a relay host. Send the message again. See Section 7.3 for more information on specifying a relay name.

I refuse to talk to myself

**Explanation:** The local host was asked to connect to itself and deliver a message.

**User Action:** Check your `sendmail` configuration by entering the following command:

```
# grep '^define(_GateINET' /var/adm/sendmail/hostname.m4
```

If the braces on any line in the output contain your host's name, there is a configuration error. Reconfigure `sendmail`. See Section 7.3 for more information.

Remote protocol error

**Explanation:** This message is generally found in the `mail.log` file generated by the `syslogd` daemon and indicates a problem in communicating with the remote host.

**User Action:** No user action is necessary; the message will be retried later.

Service unavailable

This is a secondary error message. Some other error has occurred that caused `sendmail` to interpret an address as an action.

**User Action:** Look for other error messages, for example `Host unknown`, and resolve them first. Resolving other errors should resolve this error as well.

User unknown/Addressee unknown

**Explanation:** The message reached the final destination, but the user address was not found in the local `aliases` file or the local password file at the final destination.

**User Action:** Verify that the user's address is correct.

# F

---

## Host Resources MIB Implementation

The Tru64 UNIX Simple Network Management Protocol (SNMP) agent implements the Host Resources MIB as described in RFC 1514. Although the RFC describes conceptual objects for management of host systems, it describes them in very general terms.

This appendix describes the Tru64 UNIX Host MIB implementation, including each group or table defined in RFC 1514 (with sample data). The formatting of SNMP data is specific to the implementation of an application. Compaq currently does not ship an application that presents SNMP data in this manner with Tru64 UNIX.

### F.1 Tru64 UNIX Implementation Summary

The basic Tru64 UNIX implementation of RFC 1514 is as follows:

- The RFC specifies that when a product registry does not exist, all MIB variables of type `ProductID` return an object identifier of 0.0.
- The values of the `hrDeviceIndex` and `hrFSIndex` parameters remain unique between system reboots.
- Write access is not implemented for any Host MIB object.

### F.2 System Group

The system group object implementation notes are as follows:

- The `hrSystemInitialLoadDevice` parameter is not implemented.
- The `hrSystemInitialLoadParameters` parameter returns the name of the booted kernel.

The following are sample data:

```
{hrSystemUptime.0           , TimeTicks, 0d 23:00:20.00}
{hrSystemDate.0            , OCTET STRING, 1995-11-28,15:31:52.01}
{hrSystemInitialLoadParameters.0 , OCTET STRING, vmunix}
{hrSystemNumUsers.0        , Gauge, 0}
{hrSystemProcesses.0      , Gauge, 20}
{hrSystemMaxProcesses.0   , INTEGER, 1024}
```

## F.3 Storage Group

The operating system software represents three types of logical storage: swap space, kernel memory, and file systems. The storage group object implementation is as follows:

- One entry in the `hrStorageTable` group is the total kernel memory being used.
- One entry is the current total swap space. (The value of the `hrStorageAllocationFailures` parameter for this entry is always 0.)
- There are several entries that each describe a specific type of kernel memory (the kernel malloc table). There is an entry for each memory type listed in the `<sys/malloc.h>` header file that is implemented on that particular host. (The value of the `hrStorageDescr` parameter is derived from the `malloc.h` file.)

---

### Note

---

These entries do not represent actual fixed-size memory pools that could be exhausted. They do, however, indicate how system memory is being utilized amongst the various subsystems.

---

The value of the `hrStorageSize` parameter for the kernel memory entries is always 0, because there is no actual limit.

- There is one entry in the `hrStorageTable` group for each locally mounted file system. As specified in RFC 1514, remotely mounted file systems are not represented in the `hrStorageTable` group.
- The value of the `hrStorageDescr` parameter for file system-related entries is the same as the `hrFSMountedPoint` parameter for the same file system in the `hrFSSTable` group.
- The values of the `hrStorageIndex` parameter for file system-related entries is returned in the `hrFSStorageIndex` variable for the same file system in the `hrFSSTable` group.
- The value of the `hrStorageType` parameter for file system storage entries is always `hrStorageOther`.

See Section F.5 for information on the file system implementation.

The following are sample storage group data:

```
{hrStorageIndex.1          , INTEGER, 1}
{hrStorageType.1         , OBJECT IDENTIFIER, hrStorageRam}
{hrStorageDescr.1        , OCTET STRING, Total Kernel Memory}
{hrStorageAllocationUnits.1 , INTEGER, 1024}
{hrStorageSize.1         , INTEGER, 2088960}
{hrStorageUsed.1         , INTEGER, 261112}
```



```

{hrStorageAllocationFailures.1 , Counter, 0}
{hrStorageIndex.2 , INTEGER, 2}
{hrStorageType.2 , OBJECT IDENTIFIER, hrStorageVirtualMemory}
{hrStorageDescr.2 , OCTET STRING, Total Swap Space}
{hrStorageAllocationUnits.2 , INTEGER, 1024}
{hrStorageSize.2 , INTEGER, 200704}
{hrStorageUsed.2 , INTEGER, 11920}
{hrStorageAllocationFailures.2 , Counter, 0}
{hrStorageIndex.3 , INTEGER, 3}
{hrStorageType.3 , OBJECT IDENTIFIER, hrStorageRam}
{hrStorageDescr.3 , OCTET STRING, MBUF}
{hrStorageAllocationUnits.3 , INTEGER, 1}
{hrStorageSize.3 , INTEGER, 0}
{hrStorageUsed.3 , INTEGER, 4096}
{hrStorageAllocationFailures.3 , Counter, 0}
{hrStorageIndex.4 , INTEGER, 4}
{hrStorageType.4 , OBJECT IDENTIFIER, hrStorageRam}
{hrStorageDescr.4 , OCTET STRING, MCLUSTER}
{hrStorageAllocationUnits.4 , INTEGER, 1}
{hrStorageSize.4 , INTEGER, 0}
{hrStorageUsed.4 , INTEGER, 32768}
{hrStorageAllocationFailures.4 , Counter, 0}
:
:
{hrStorageIndex.99 , INTEGER, 99}
{hrStorageType.99 , OBJECT IDENTIFIER, hrStorageOther}
{hrStorageDescr.99 , OCTET STRING, /}
{hrStorageAllocationUnits.99 , INTEGER, 1024}
{hrStorageSize.99 , INTEGER, 63167}
{hrStorageUsed.99 , INTEGER, 46098}
{hrStorageAllocationFailures.99 , Counter, 0}
{hrStorageIndex.100 , INTEGER, 100}
{hrStorageType.100 , OBJECT IDENTIFIER, hrStorageOther}
{hrStorageDescr.100 , OCTET STRING, /proc}
{hrStorageAllocationUnits.100 , INTEGER, 8192}
{hrStorageSize.100 , INTEGER, 0}
{hrStorageUsed.100 , INTEGER, 0}
{hrStorageAllocationFailures.100 , Counter, 0}
{hrStorageIndex.101 , INTEGER, 101}
{hrStorageType.101 , OBJECT IDENTIFIER, hrStorageOther}
{hrStorageDescr.101 , OCTET STRING, /usr}
{hrStorageAllocationUnits.101 , INTEGER, 1024}
{hrStorageSize.101 , INTEGER, 866102}
{hrStorageUsed.101 , INTEGER, 596323}
{hrStorageAllocationFailures.101 , Counter, 0}

```

## F.4 Device Tables

This implementation supports CPUs, network interfaces, and disks in the device-related tables; printers are not supported. The CPU support is as follows:

- Each CPU physically attached to the system is represented in both the `hrDevice` and `hrProcessor` tables. The value of the `hrDeviceIndex` parameter for these entries is the processor number plus 1.
- The value of the `hrDeviceErrors` parameter is always 0.
- The value of the `hrDeviceStatus` parameter is either `running` or `down`.

- The value of the `hrProcessorLoad` parameter is accurately determined for each processor running on the system. Processor idle time is any time spent in the IDLE or WAIT states. Busy time is time spent in any other state.

A background task records CPU time every 30 seconds, retaining 2 snapshots. When an SNMP request is received, CPU times are fetched immediately and the load average is calculated as the difference between this current data and the least recent snapshot. In this manner the values returned for the `hrProcessorLoad` parameter are current load averages over a period of at least 30 seconds, but not more than 1 minute. The value of the `hrProcessorLoad` parameter is calculated as follows:

$$(\text{delta } \textit{busy} / (\text{delta } \textit{busy} + \text{delta } \textit{idle})) * 100$$

The disk support is as follows:

- Each `re`, `ra`, and `rz` type disk whose special file is present in the `/dev` directory is represented in the `hrDeviceTable` group, the `hrDiskStorageTable` group, and the `hrPartitionTable` group.
- The value of the `hrDeviceStatus` parameter is running if the disk is online, or down if the disk is offline.
- The value of the `hrDeviceErrors` parameter is the sum of hard and soft errors reported for the disk.
- The value of the `hrDiskStorageMedia` parameter is always unknown.
- Data cannot be retrieved currently for offline devices (for instance, an empty CD-ROM drive). In these cases, the `hrDiskStorage` entry is as follows:

```
media = 'unknown'
capacity = 0
removable = 'false'
access = 'readWrite'
```

The value of the `hrPartitionFSIndex` parameter is either zero (0) or the value of the `hrFSIndex` parameter for the `hrFS`Table entry corresponding to the offline file system.

The network device support is as follows:

- Each network interface is represented in both the `hrDeviceTable` group and `hrNetworkTable` group.
- The value of the `hrDeviceStatus` parameter is running if the interface is running, down if the interface is not up, or unknown.
- The value of the `hrDeviceErrors` parameter is the sum of inbound and outbound packet errors on that interface.

- The value of the hrNetworkIfIndex parameter is the same as the MIB-II value of the ifIndex parameter for that interface.

The following are sample device table data:

```

{hrDeviceIndex.1          , INTEGER, 1}
{hrDeviceType.1          , OBJECT IDENTIFIER, hrDeviceProcessor}
{hrDeviceDescr.1         , OCTET STRING, Digital 2100 Server Model A500MP}
{hrDeviceID.1            , OBJECT IDENTIFIER, 0.0}
{hrDeviceStatus.1        , INTEGER, running}
{hrDeviceErrors.1        , Counter, 0}
{hrDeviceIndex.2         , INTEGER, 2}
{hrDeviceType.2          , OBJECT IDENTIFIER, hrDeviceProcessor}
{hrDeviceDescr.2         , OCTET STRING, Digital 2100 Server Model A500MP}
{hrDeviceID.2            , OBJECT IDENTIFIER, 0.0}
{hrDeviceStatus.2        , INTEGER, running}
{hrDeviceErrors.2        , Counter, 0}
{hrDeviceIndex.3         , INTEGER, 3}
{hrDeviceType.3          , OBJECT IDENTIFIER, hrDeviceProcessor}
{hrDeviceDescr.3         , OCTET STRING, Digital 2100 Server Model A500MP}
{hrDeviceID.3            , OBJECT IDENTIFIER, 0.0}
{hrDeviceStatus.3        , INTEGER, running}
{hrDeviceErrors.3        , Counter, 0}
{hrDeviceIndex.4         , INTEGER, 4}
{hrDeviceType.4          , OBJECT IDENTIFIER, hrDeviceProcessor}
{hrDeviceDescr.4         , OCTET STRING, Digital 2100 Server Model A500MP}
{hrDeviceID.4            , OBJECT IDENTIFIER, 0.0}
{hrDeviceStatus.4        , INTEGER, running}
{hrDeviceErrors.4        , Counter, 0}
{hrDeviceIndex.5         , INTEGER, 5}
{hrDeviceType.5          , OBJECT IDENTIFIER, hrDeviceNetwork}
{hrDeviceDescr.5         , OCTET STRING, tu0 - DEC TULIP Ethernet Interface}
{hrDeviceID.5            , OBJECT IDENTIFIER, 0.0}
{hrDeviceStatus.5        , INTEGER, running}
{hrDeviceErrors.5        , Counter, 9}
{hrDeviceIndex.6         , INTEGER, 6}
{hrDeviceType.6          , OBJECT IDENTIFIER, hrDeviceNetwork}
{hrDeviceDescr.6         , OCTET STRING, tra0 - DEC DW300 Token Ring Interface}
{hrDeviceID.6            , OBJECT IDENTIFIER, 0.0}
{hrDeviceStatus.6        , INTEGER, down}
{hrDeviceErrors.6        , Counter, 0}
{hrDeviceIndex.7         , INTEGER, 7}
{hrDeviceType.7          , OBJECT IDENTIFIER, hrDeviceNetwork}
{hrDeviceDescr.7         , OCTET STRING, ln0 - DEC LANCE Ethernet Interface}
{hrDeviceID.7            , OBJECT IDENTIFIER, 0.0}
{hrDeviceStatus.7        , INTEGER, running}
{hrDeviceErrors.7        , Counter, 40}
{hrDeviceIndex.8         , INTEGER, 8}
{hrDeviceType.8          , OBJECT IDENTIFIER, hrDeviceNetwork}
{hrDeviceDescr.8         , OCTET STRING, sl0 - Serial Line Interface}
{hrDeviceID.8            , OBJECT IDENTIFIER, 0.0}
{hrDeviceStatus.8        , INTEGER, down}
{hrDeviceErrors.8        , Counter, 0}
{hrDeviceIndex.9         , INTEGER, 9}
{hrDeviceType.9          , OBJECT IDENTIFIER, hrDeviceNetwork}
{hrDeviceDescr.9         , OCTET STRING, lo0 - Local Loopback Interface.}
{hrDeviceID.9            , OBJECT IDENTIFIER, 0.0}
{hrDeviceStatus.9        , INTEGER, unknown}
{hrDeviceErrors.9        , Counter, 0}
{hrDeviceIndex.10        , INTEGER, 10}
{hrDeviceType.10         , OBJECT IDENTIFIER, hrDeviceNetwork}
{hrDeviceDescr.10        , OCTET STRING, ppp0 - 2.2}
{hrDeviceID.10           , OBJECT IDENTIFIER, 0.0}
{hrDeviceStatus.10       , INTEGER, down}

```

```

{hrDeviceErrors.10          , Counter, 0}
{hrDeviceIndex.11         , INTEGER, 11}
{hrDeviceType.11          , OBJECT IDENTIFIER, hrDeviceDiskStorage}
{hrDeviceDescr.11         , OCTET STRING, /dev/rz0 - SCSI RZ28}
{hrDeviceID.11            , OBJECT IDENTIFIER, 0.0}
{hrDeviceStatus.11        , INTEGER, running}
{hrDeviceErrors.11        , Counter, 0}
{hrDeviceIndex.12         , INTEGER, 12}
{hrDeviceType.12          , OBJECT IDENTIFIER, hrDeviceDiskStorage}
{hrDeviceDescr.12         , OCTET STRING, /dev/rz1 - SCSI RZ28}
{hrDeviceID.12            , OBJECT IDENTIFIER, 0.0}
{hrDeviceStatus.12        , INTEGER, running}
{hrDeviceErrors.12        , Counter, 0}
{hrDeviceIndex.13         , INTEGER, 13}
{hrDeviceType.13          , OBJECT IDENTIFIER, hrDeviceDiskStorage}
{hrDeviceDescr.13         , OCTET STRING, /dev/rz6 - SCSI RRD43}
{hrDeviceID.13            , OBJECT IDENTIFIER, 0.0}
{hrDeviceStatus.13        , INTEGER, down}
{hrDeviceErrors.13        , Counter, 0}
{hrProcessorFrwID.1       , OBJECT IDENTIFIER, 0.0}
{hrProcessorLoad.1        , INTEGER, 4}
{hrProcessorFrwID.2       , OBJECT IDENTIFIER, 0.0}
{hrProcessorLoad.2        , INTEGER, 0}
{hrProcessorFrwID.3       , OBJECT IDENTIFIER, 0.0}
{hrProcessorLoad.3        , INTEGER, 10}
{hrProcessorFrwID.4       , OBJECT IDENTIFIER, 0.0}
{hrProcessorLoad.4        , INTEGER, 19}
{hrDiskStorageAccess.11   , INTEGER, readWrite}
{hrDiskStorageMedia.11    , INTEGER, unknown}
{hrDiskStorageRemoveble.11 , INTEGER, false}
{hrDiskStorageCapacity.11 , INTEGER, 2055240}
{hrDiskStorageAccess.12   , INTEGER, readWrite}
{hrDiskStorageMedia.12    , INTEGER, unknown}
{hrDiskStorageRemoveble.12 , INTEGER, false}
{hrDiskStorageCapacity.12 , INTEGER, 2055240}
{hrDiskStorageAccess.13   , INTEGER, readWrite}
{hrDiskStorageMedia.13    , INTEGER, unknown}
{hrDiskStorageRemoveble.13 , INTEGER, false}
{hrDiskStorageCapacity.13 , INTEGER, 0}
{hrPartitionIndex.11.1    , INTEGER, 1}
{hrPartitionLabel.11.1    , OCTET STRING, /dev/rz0a}
{hrPartitionID.11.1       , OCTET STRING, }
{hrPartitionSize.11.1     , INTEGER, 65536}
{hrPartitionFSIndex.11.1  , INTEGER, 1}
{hrPartitionIndex.11.2    , INTEGER, 2}
{hrPartitionLabel.11.2    , OCTET STRING, /dev/rz0b}
{hrPartitionID.11.2       , OCTET STRING, }
{hrPartitionSize.11.2     , INTEGER, 200704}
{hrPartitionFSIndex.11.2  , INTEGER, 0}
{hrPartitionIndex.11.3    , INTEGER, 3}
{hrPartitionLabel.11.3    , OCTET STRING, /dev/rz0c}
{hrPartitionID.11.3       , OCTET STRING, }
{hrPartitionSize.11.3     , INTEGER, 2055240}
{hrPartitionFSIndex.11.3  , INTEGER, 0}
{hrPartitionIndex.11.4    , INTEGER, 4}
{hrPartitionLabel.11.4    , OCTET STRING, /dev/rz0d}
{hrPartitionID.11.4       , OCTET STRING, }
{hrPartitionSize.11.4     , INTEGER, 595968}
{hrPartitionFSIndex.11.4  , INTEGER, 0}
{hrPartitionIndex.11.5    , INTEGER, 5}
{hrPartitionLabel.11.5    , OCTET STRING, /dev/rz0e}
{hrPartitionID.11.5       , OCTET STRING, }
{hrPartitionSize.11.5     , INTEGER, 595968}
{hrPartitionFSIndex.11.5  , INTEGER, 0}

```

```

{hrPartitionIndex.11.6      , INTEGER, 6}
{hrPartitionLabel.11.6     , OCTET STRING, /dev/rz0f}
{hrPartitionID.11.6        , OCTET STRING, }
{hrPartitionSize.11.6      , INTEGER, 597064}
{hrPartitionFSIndex.11.6   , INTEGER, 0}
{hrPartitionIndex.11.7     , INTEGER, 7}
{hrPartitionLabel.11.7     , OCTET STRING, /dev/rz0g}
{hrPartitionID.11.7        , OCTET STRING, }
{hrPartitionSize.11.7      , INTEGER, 893952}
{hrPartitionFSIndex.11.7   , INTEGER, 3}
{hrPartitionIndex.11.8     , INTEGER, 8}
{hrPartitionLabel.11.8     , OCTET STRING, /dev/rz0h}
{hrPartitionID.11.8        , OCTET STRING, }
{hrPartitionSize.11.8      , INTEGER, 895048}
{hrPartitionFSIndex.11.8   , INTEGER, 0}
{hrPartitionIndex.12.1     , INTEGER, 1}
{hrPartitionLabel.12.1     , OCTET STRING, /dev/rz1a}
{hrPartitionID.12.1        , OCTET STRING, }
{hrPartitionSize.12.1      , INTEGER, 65536}
{hrPartitionFSIndex.12.1   , INTEGER, 0}
{hrPartitionIndex.12.2     , INTEGER, 2}
{hrPartitionLabel.12.2     , OCTET STRING, /dev/rz1b}
{hrPartitionID.12.2        , OCTET STRING, }
{hrPartitionSize.12.2      , INTEGER, 200704}
{hrPartitionFSIndex.12.2   , INTEGER, 0}
{hrPartitionIndex.12.3     , INTEGER, 3}
{hrPartitionLabel.12.3     , OCTET STRING, /dev/rz1c}
{hrPartitionID.12.3        , OCTET STRING, }
{hrPartitionSize.12.3      , INTEGER, 2055240}
{hrPartitionFSIndex.12.3   , INTEGER, 0}
{hrPartitionIndex.12.4     , INTEGER, 4}
{hrPartitionLabel.12.4     , OCTET STRING, /dev/rz1d}
{hrPartitionID.12.4        , OCTET STRING, }
{hrPartitionSize.12.4      , INTEGER, 595968}
{hrPartitionFSIndex.12.4   , INTEGER, 0}
{hrPartitionIndex.12.5     , INTEGER, 5}
{hrPartitionLabel.12.5     , OCTET STRING, /dev/rz1e}
{hrPartitionID.12.5        , OCTET STRING, }
{hrPartitionSize.12.5      , INTEGER, 595968}
{hrPartitionFSIndex.12.5   , INTEGER, 0}
{hrPartitionIndex.12.6     , INTEGER, 6}
{hrPartitionLabel.12.6     , OCTET STRING, /dev/rz1f}
{hrPartitionID.12.6        , OCTET STRING, }
{hrPartitionSize.12.6      , INTEGER, 597064}
{hrPartitionFSIndex.12.6   , INTEGER, 0}
{hrPartitionIndex.12.7     , INTEGER, 7}
{hrPartitionLabel.12.7     , OCTET STRING, /dev/rz1g}
{hrPartitionID.12.7        , OCTET STRING, }
{hrPartitionSize.12.7      , INTEGER, 893952}
{hrPartitionFSIndex.12.7   , INTEGER, 0}
{hrPartitionIndex.12.8     , INTEGER, 8}
{hrPartitionLabel.12.8     , OCTET STRING, /dev/rz1h}
{hrPartitionID.12.8        , OCTET STRING, }
{hrPartitionSize.12.8      , INTEGER, 895048}
{hrPartitionFSIndex.12.8   , INTEGER, 0}
{hrNetworkIfIndex.5        , INTEGER, 1}
{hrNetworkIfIndex.6        , INTEGER, 2}
{hrNetworkIfIndex.7        , INTEGER, 3}
{hrNetworkIfIndex.8        , INTEGER, 4}
{hrNetworkIfIndex.9        , INTEGER, 5}
{hrNetworkIfIndex.10       , INTEGER, 6}

```

## F.5 File System Table

The file system table implementation is as follows:

- Each currently mounted file system is represented in the `hrFSSTable` group.
- The available values for the `hrFSSType` parameter do not cover all possible file system types in the operating system. Some types (for example, `/proc`) report a value of `hrFSOther` for the `hrFSSType` object.
- The `hrFSRemoteMountPoint` parameter is returned as a zero-length octet string for local file systems, as specified in RFC 1514.
- The `hrFSStorageIndex` parameter returns a zero (0) for remote file systems, in accordance with RFC 1514. For local file systems, the `hrFSStorageIndex` parameter returns the value of the `hrStorageIndex` parameter for the `hrStorageEntry` entry corresponding to that file system.

The RFC specifies this design, presumably so that all storage-related information is available in one table. However, in order to discover file system full conditions, an SNMP application needs to do the following:

1. Locate an entry in the the `hrFSSTable` group.
  2. Retrieve that entry's value of the `hrFSStorageIndex` parameter. For example, call it *i*.
  3. If *i* is not zero (0), retrieve the values of the `hrStorageUsed.i` and `hrStorageSize.i` parameters.
- The value of the `hrFSBootable` parameter is always returned as `false`.
  - The values of the `hrFSLastFullBackupDate` and `hrFSLastPartialBackupDate` parameters are always returned as {January 1 year 0 time 0}, in the `DateAndTime` format, as specified in RFC 1514, when these values are unknown.

The following are sample file system table data:

```
{hrFSIndex.1 , INTEGER, 1}
{hrFSMountPoint.1 , OCTET STRING, /}
{hrFSRemoteMountPoint.1 , OCTET STRING, }
{hrFSSType.1 , OBJECT IDENTIFIER, hrFSBerkeleyFFS}
{hrFSAccess.1 , INTEGER, readWrite}
{hrFSBootable.1 , INTEGER, false}
{hrFSStorageIndex.1 , INTEGER, 99}
{hrFSLastFullBackupDate.1 , OCTET STRING, 0-1-1,0:0:0.0}
{hrFSLastPartialBackupDate.1 , OCTET STRING, 0-1-1,0:0:0.0}
{hrFSIndex.2 , INTEGER, 2}
{hrFSMountPoint.2 , OCTET STRING, /proc}
{hrFSRemoteMountPoint.2 , OCTET STRING, }
{hrFSSType.2 , OBJECT IDENTIFIER, hrFSOther}
{hrFSAccess.2 , INTEGER, readWrite}
{hrFSBootable.2 , INTEGER, false}
{hrFSStorageIndex.2 , INTEGER, 100}
```

```

{hrFSLastFullBackupDate.2      , OCTET STRING, 0-1-1,0:0:0.0}
{hrFSLastPartialBackupDate.2  , OCTET STRING, 0-1-1,0:0:0.0}
{hrFSIndex.3                   , INTEGER, 3}
{hrFSMountPoint.3              , OCTET STRING, /usr}
{hrFSRemoteMountPoint.3       , OCTET STRING, }
{hrFSType.3                    , OBJECT IDENTIFIER, hrFSBerkeleyFFS}
{hrFSAccess.3                  , INTEGER, readWrite}
{hrFSBootable.3                , INTEGER, false}
{hrFSStorageIndex.3           , INTEGER, 101}
{hrFSLastFullBackupDate.3     , OCTET STRING, 0-1-1,0:0:0.0}
{hrFSLastPartialBackupDate.3  , OCTET STRING, 0-1-1,0:0:0.0}
{hrFSIndex.4                   , INTEGER, 4}
{hrFSMountPoint.4              , OCTET STRING, /tools}
{hrFSRemoteMountPoint.4       , OCTET STRING, /tools@tools}
{hrFSType.4                    , OBJECT IDENTIFIER, hrFSNFS}
{hrFSAccess.4                  , INTEGER, readWrite}
{hrFSBootable.4                , INTEGER, false}
{hrFSStorageIndex.4           , INTEGER, 0}
{hrFSLastFullBackupDate.4     , OCTET STRING, 0-1-1,0:0:0.0}
{hrFSLastPartialBackupDate.4  , OCTET STRING, 0-1-1,0:0:0.0}

```

## F.6 Running Software Tables

The running software table implementation is as follows:

- The `hrSWOSIndex` parameter is always returned as zero (0), the kernel idle process. There is no one process that represents the primary operating system running on this host for Tru64 UNIX.
- Each process is represented as an entry in both the `hrSWRunTable` group and the `hrSWRunPerfTable` group. The value of the `hrSWRunIndex` parameter (used to index both tables) is the pid of that process. This means there is an entry whose `hrSWRunIndex` parameter value is 0 (zero), which is not typical of SNMP tables.
- The `hrSWRunName` parameter is always returned as a zero-length octet string.
- The `hrSWRunType` parameter is always returned as unknown.
- The `hrSWRunStatus` parameter is returned as either running (processes that are capable of being run or are waiting for CPU), or `notrunnable` (stopped or waiting for non-CPU resources).
- The `hrSWRunPath` parameter and the `hrSWRunParameters` parameter return the command and parameters, respectively, that were used to start this process. This is similar, but not identical, to the output of the `ps` command.
- The `hrSWRunPerfCPU` parameter returns the sum of accumulated system and user time for all threads running in a process. This value is equivalent to the value returned by the `ps cputime` specifier (adjusted to units of centiseconds).
- The `hrSWRunPerfMem` parameter returns the current resident set size of the process. This value is equivalent to the value returned by the `ps`

rssize specifier, adjusted to units of 1024 bytes (a "Kbyte" as defined in RFC 1514).

The following are sample running software table data:

```

{hrSWRunIndex.0           , INTEGER, 0}
{hrSWRunName.0           , OCTET STRING, }
{hrSWRunID.0             , OBJECT IDENTIFIER, 0.0}
{hrSWRunPath.0          , OCTET STRING, }
{hrSWRunParameters.0    , OCTET STRING, }
{hrSWRunType.0          , INTEGER, unknown}
{hrSWRunStatus.0        , INTEGER, running}
{hrSWRunIndex.1         , INTEGER, 1}
{hrSWRunName.1          , OCTET STRING, }
{hrSWRunID.1            , OBJECT IDENTIFIER, 0.0}
{hrSWRunPath.1          , OCTET STRING, /sbin/init}
{hrSWRunParameters.1    , OCTET STRING, -a}
{hrSWRunType.1          , INTEGER, unknown}
{hrSWRunStatus.1        , INTEGER, notRunnable}
{hrSWRunIndex.3         , INTEGER, 3}
{hrSWRunName.3          , OCTET STRING, }
{hrSWRunID.3            , OBJECT IDENTIFIER, 0.0}
{hrSWRunPath.3          , OCTET STRING, /sbin/kloadsrv}
{hrSWRunParameters.3    , OCTET STRING, }
{hrSWRunType.3          , INTEGER, unknown}
{hrSWRunStatus.3        , INTEGER, notRunnable}
{hrSWRunIndex.16        , INTEGER, 16}
{hrSWRunName.16         , OCTET STRING, }
{hrSWRunID.16           , OBJECT IDENTIFIER, 0.0}
{hrSWRunPath.16         , OCTET STRING, /sbin/update}
{hrSWRunParameters.16   , OCTET STRING, }
{hrSWRunType.16         , INTEGER, unknown}
{hrSWRunStatus.16       , INTEGER, notRunnable}
:
:
{hrSWRunIndex.142        , INTEGER, 142}
{hrSWRunName.142         , OCTET STRING, }
{hrSWRunID.142           , OBJECT IDENTIFIER, 0.0}
{hrSWRunPath.142        , OCTET STRING, /usr/sbin/routed}
{hrSWRunParameters.142  , OCTET STRING, -q}
{hrSWRunType.142        , INTEGER, unknown}
{hrSWRunStatus.142      , INTEGER, notRunnable}
{hrSWRunIndex.228        , INTEGER, 228}
{hrSWRunName.228         , OCTET STRING, }
{hrSWRunID.228           , OBJECT IDENTIFIER, 0.0}
{hrSWRunPath.228        , OCTET STRING, /usr/sbin/nfsiod}
{hrSWRunParameters.228  , OCTET STRING, 7}
{hrSWRunType.228        , INTEGER, unknown}
{hrSWRunStatus.228      , INTEGER, notRunnable}
{hrSWRunIndex.394        , INTEGER, 394}
{hrSWRunName.394         , OCTET STRING, }
{hrSWRunID.394           , OBJECT IDENTIFIER, 0.0}
{hrSWRunPath.394        , OCTET STRING, /usr/bin/dtlogin}
{hrSWRunParameters.394  , OCTET STRING, -daemon}
{hrSWRunType.394        , INTEGER, unknown}
{hrSWRunStatus.394      , INTEGER, notRunnable}
{hrSWRunIndex.395        , INTEGER, 395}
{hrSWRunName.395         , OCTET STRING, }
{hrSWRunID.395           , OBJECT IDENTIFIER, 0.0}
{hrSWRunPath.395        , OCTET STRING, /usr/sbin/getty}
{hrSWRunParameters.395  , OCTET STRING, console console vt100}
{hrSWRunType.395        , INTEGER, unknown}
{hrSWRunStatus.395      , INTEGER, notRunnable}
{hrSWRunIndex.396        , INTEGER, 396}

```



```

{hrSWRunName.396           , OCTET STRING, }
{hrSWRunID.396            , OBJECT IDENTIFIER, 0.0}
{hrSWRunPath.396         , OCTET STRING, /usr/bin/X11/X}
{hrSWRunParameters.396   , OCTET STRING, :0 -auth /var/dt/A:0-aaamka}
{hrSWRunType.396         , INTEGER, unknown}
{hrSWRunStatus.396       , INTEGER, notRunnable}
{hrSWRunIndex.397        , INTEGER, 397}
{hrSWRunName.397         , OCTET STRING, }
{hrSWRunID.397           , OBJECT IDENTIFIER, 0.0}
{hrSWRunPath.397         , OCTET STRING, dtlogin}
{hrSWRunParameters.397   , OCTET STRING, <:0> -daemon}
{hrSWRunType.397         , INTEGER, unknown}
{hrSWRunStatus.397       , INTEGER, notRunnable}
:
:
{hrSWRunPerfCPU.0        , INTEGER, 9288}
{hrSWRunPerfMem.0        , INTEGER, 10024}
{hrSWRunPerfCPU.1        , INTEGER, 34}
{hrSWRunPerfMem.1        , INTEGER, 64}
{hrSWRunPerfCPU.3        , INTEGER, 17}
{hrSWRunPerfMem.3        , INTEGER, 2000}
{hrSWRunPerfCPU.16       , INTEGER, 4476}
{hrSWRunPerfMem.16       , INTEGER, 88}
:
:
{hrSWRunPerfCPU.142      , INTEGER, 891}
{hrSWRunPerfMem.142     , INTEGER, 112}
{hrSWRunPerfCPU.228      , INTEGER, 0}
{hrSWRunPerfMem.228     , INTEGER, 56}
{hrSWRunPerfCPU.394     , INTEGER, 51}
{hrSWRunPerfMem.394     , INTEGER, 264}
{hrSWRunPerfCPU.395     , INTEGER, 7}
{hrSWRunPerfMem.395     , INTEGER, 80}
{hrSWRunPerfCPU.396     , INTEGER, 4329}
{hrSWRunPerfMem.396     , INTEGER, 2648}
{hrSWRunPerfCPU.397     , INTEGER, 8}
{hrSWRunPerfMem.397     , INTEGER, 232}
:
:

```



# G

---

## Format of DNS Data File Entries

The Domain Name System (DNS) configuration file, by default called `/etc/namedb/named.conf`, specifies the names of the DNS data files. These data files consist of entries, also known as Resource Records (RR), that follow the formats described in this chapter.

### G.1 Format of DNS Resource Records

Here is the general format of a DNS Resource Record:

*name ttl addr-class entry-type entry-specific-data*

The fields are defined as follows:

| Field       | Description   |
|-------------|---|
| <i>name</i> | <p>This is the name of the domain, for example <code>cities.dec.com</code>. The domain name must begin in the first column.</p> <p>For some data file entries the name field is left blank. In that case, the domain name is assumed to be the same as the previous entry.</p> <p>A free standing period (<code>.</code>) refers to the current domain.</p> <p>A free standing at sign (<code>@</code>) denotes the current origin, thus allowing you to specify more than one domain.</p> <p>Two free standing periods (<code>..</code>) represent the null domain name of the root.</p> |
| <i>ttl</i>  | <p>This is the time-to-live field, and specifies how long, in seconds, the data will be stored in the database. If this field is left blank, the value defaults to the <code>ttl</code> value specified in the SOA (start of authority) entry or, ultimately, the value of the <code>\$ttl</code> entry. The maximum time-to-live is 99999999 seconds, or 3 years.</p>  |

| Field                      | Description  |
|----------------------------|--|
| <i>addr-class</i>          | This field is the address class. There are three classes: IN — Internet addresses, TXT — naming service data, ANY — all other types of network addresses.<br><br>The address class of all data file entries of a given entry-type in a particular zone must be the same. Therefore, only the first entry in a zone need specify the <i>addr-class</i> field. |
| <i>entry-type</i>          | This field states the resource record type, for example SOA (start of authority) or A (address).   |
| <i>entry-specific-data</i> | All fields after the entry-type field vary for each type of data file entry (resource record).   |

The case is preserved in name and data fields when loaded into the DNS server. Comparisons and lookups using the DNS are case insensitive.

The following characters have special meanings in DNS data file entries:

| Character         | Meaning   |
|-------------------|---|
| <code>\x</code>   | A backslash (\) escapes the next nondigit (x) character so that the character's special meaning does not apply. For example, you could use a period (.) to place a period character in a label. |
| <code>\nnn</code> | A backslash denotes the octet corresponding to the decimal number represented by nnn. The resulting octet is assumed to be text and is not checked for special meaning.                         |
| <code>()</code>   | Parentheses group data that cross a line. In effect, line terminations are not recognized within parentheses.   |
| <code>;</code>    | A semicolon starts a comment, causing the rest of the line to be ignored.   |
| <code>*</code>    | An asterisk signifies a wildcard.   |

Most DNS data file entries have the current domain appended to their names if they are not terminated by a period (.). This is useful for appending the current domain name to the data, such as system names, but could cause problems when you do not want this to happen. Consequently, if the name is not in the domain for which you are creating the data file, end the name with a period.

Data files (resource records) can have the following types of entries:

- `$include`
- `$origin`

- `$ttl` — time to live
- `A` — address
- `CNAME` — canonical name
- `HINFO` — host information
- `MB` — mail box
- `MG` — mail group
- `MINFO` — mailbox information
- `MR` — mail rename
- `MX` — mail exchanger
- `NS` — name server
- `PTR` — domain name pointer
- `SOA` — start of authority
- `WKS` — well known services

## G.2 Description of Data File Entries

The following sections describe each data file entry and its format.

### G.2.1 Include Entry

An include entry is similar to a header file in the C programming language. This feature is particularly useful for separating different types of data into multiple files. An include entry begins with `$include` in the first column, and is followed by the name of the file to be included. For example:

```
$include /etc/namedb/mailboxes
```

This entry requests the DNS to load the data file `/etc/namedb/mailboxes`.

The include entry loads data files into the local zone and acts as a data file organizer. For example, you can use `$include` entries to separate mail from host information.

### G.2.2 Origin Entry

An origin entry changes the origin in a data file. This feature is particularly useful for putting more than one domain in a data file. An origin entry begins with `$origin` in the first column, followed by a domain origin, as shown in the following example:

```
$origin state.dec.com.
```

This entry includes the domain `state.dec.com` in the data file. As a result, the DNS can provide information about the `state.dec.com` domain in addition to the local domain, provided your server has authority for the zone.

The `$origin` and `$include` entries can work together. They can save typing and help keep the files organized. For example, assume that the following entries are in the `hosts.rev` file:

```
$origin 11.128.in-addr.arpa.  
$include cities.dec.com.rev
```

The period after `arpa` signifies the complete domain name. Assume that the `cities.dec.com.rev` file consists of entries similar to the following:

```
33.22 IN PTR chicago.cities.dec.com.
```

In this situation, the complete reverse name for the host `chicago` is translated to be as follows:

```
33.22.11.128. in-addr.arpa. IN PTR chicago.cities.dec.com.
```

### G.2.3 TTL Entry

The time-to-live entry is similar to the `ttl` field in other resource records; it specifies how long data will be stored in the cache. However, when you set the time-to-live in the optional `$ttl` entry, the limit takes effect only if no time-to-live value is specified for a particular resource record or its corresponding SOA record.

A `$ttl` entry begins with `$ttl` in the first column, a value in the second column, and an optional comment in the third column. For example, this entry specifies that resource records without a specified `ttl` will expire after 21600 seconds (or six hours):

```
$ttl 21600 default time to live
```

When you specify it in this manner, the time-to-live value must be in the range of 0 to 2147483647 seconds. Alternatively, you can specify the time-to-live in the following format, where you need not specify all of the fields:

```
weeksWdaysDhoursHminutesMsecondsS
```

For example, the maximum value in this format (3550 weeks, 5 days, 3 hours, 14 minutes, 7 seconds) would be specified as follows:

```
$ttl 3550W5D3H14M7S
```

### G.2.4 Address Entry

The address (A) data file entry lists the address for a specific system. An A entry has the following format:

*name ttl addr-class entry-type address*

The fields in the A entry have the values described in Section G.1, with the exception of the *address* field. This field specifies the IP address for each system. There must be only one A entry for each address on a given system.

The following is an example of two A entries:

```
;name          ttl    addr-class  entry-type  address
miaml.cities.dec.com.      IN      A           A           128.11.22.44
                        IN      A           A           128.11.22.33
```

In this example, note that in the first entry the *ttl* field is blank, thus using the default *ttl* specified in the SOA entry or the *\$ttl* entry. In the second entry, the first and second fields are blank, thus using the default name specified in the previous entry and the same default *ttl*. In this example, the host *miami.cities.dec.com* has two IP addresses.

## G.2.5 Canonical Name Entry

The canonical name (CNAME) entry specifies an alias for a canonical name. For example, if the canonical name, (also known as the full DNS name or the fully qualified name) is *miami.cities.dec.com*, a reasonable alias might be *miami* or *mi*.

An alias must be unique, and all other entries must be associated with the canonical name and not with the alias. Do not create an alias and then use it in other entries. A CNAME entry has the following format:

*aliases ttl addr-class entry-type can-name*

The fields in the CNAME entry have the values described in Section G.1, with the following exceptions:

| Field           | Description   |
|-----------------|---|
| <i>alias</i>    | This field specifies the nickname (alias) of the canonical name of the host.  |
| <i>can-name</i> | This is the canonical name of the host. If the canonical name is a part of the current domain, you need to specify only the host name, for example, <i>miami</i> . If the canonical name is for a host in another domain, you must specify the fully qualified DNS name, followed by a period (.). For example: <i>ohio.state.dec.com</i> . |

The following example shows two CNAME entries. The first entry is for a CNAME in the current domain, *cities.dec.com*; the second entry is for a CNAME in another domain:

```
;aliases      ttl    addr-class  entry-type  can-name
to           IN      CNAME      CNAME      toledo
```

```
oh                IN                CNAME                ohio.state.dec.com.
```

## G.2.6 Host Information Entry

The host information (HINFO) data file entry is for host specific information. This entry lists the hardware and operating system that are running at the specified host system. Only a single space separates the name of the hardware from the operating system information. Thus, if you need to use spaces as part of a host or operating system name, you must place the name in quotation marks. In addition, there can be no more than one HINFO entry for each host on the domain. The following is the HINFO entry format:

```
host ttl addr-class entry-type hardware opsys
```

The fields in the HINFO entry have the values described in Section G.1, with the following exceptions:

| Field           | Description  |
|-----------------|--|
| <i>host</i>     | This field specifies the host name. If the host is in the current domain, you need to specify only the host, for example, <i>chicago</i> . If the host is in a different domain, you must specify the full DNS name, for example, <i>utah.state.dec.com.</i> . Be sure to include the period (.) at the end of the host name. This indicates the fully qualified DNS name. |
| <i>hardware</i> | This field specifies the type of CPU, for example, an AlphaServer 8400.  |
| <i>opsys</i>    | This field specifies the type of operating system running on the specified host. Its recommended setting is Tru64 UNIX for the Tru64 UNIX operating system.  |

The following is an example of a HINFO entry:

```
;name          ttl  addr-class  entry-type  hardware          opsys
ohio.state.dec.com.  IN      HINFO      "AlphaServer
8400"         "Tru64 UNIX"
```

In this example, note that the second field specifying the *ttl* is blank, thus using the default *ttl* specified in the SOA entry or the *\$ttl* entry.

## G.2.7 Mailbox Entry

The mailbox (MB) entry lists the system where a user wants to receive mail. The following is the format of an MB entry:

```
login ttl addr-class entry-type system
```

The fields in the MB entry have the values described in Section G.1, with the following exceptions:



| Field         | Description   |
|---------------|---|
| <i>login</i>  | This field is the login name for a user. Login names must be unique for the domain. |
| <i>system</i> | This field specifies the name system where the user wants to receive mail.          |

The following is an example of an MB entry:

```
;login    ttl    addr-class  entry-type  system
fred      IN      MB          potsdam.cities.dec.com.
```

In this example, note that the second field is blank, thus using the default ttl specified in the SOA entry or the \$ttl entry. Consequently, the user Fred will have mail delivered to the host named potsdam in the domain cities.dec.com.

## G.2.8 Mail Group Entry

The mail group (MG) entry specifies the members of a mail group. The MG entry is usually used with a MINFO entry. The following is the format of an MG entry:

```
group  ttl  addr-class  entry-type  member
```

The fields in the MG entry have the values described in Section G.1, with the following exceptions:

| Field         | Description  |
|---------------|--|
| <i>group</i>  | This field specifies the name of the mail group, for example, users or marketing.                |
| <i>member</i> | This field specifies the login name and the domain of the user to be included in the mail group. |

The following is an example of a MINFO entry and several MG entries:

```
;group  ttl    addr-class  entry-type  requests  member
fun      IN      MINFO      BIND-REQUEST  fred@miami.cities.dec.com.
          IN      MG         john@miami.cities.dec.com.
amy@miami.cities.dec.com.
```

In this example, note that the second field for all three entries is blank, thus using the default ttl specified in the SOA entry or the \$ttl entry. In addition, Fred, John, and Amy will receive any mail sent to the mail group fun.

## G.2.9 Mailbox Information Entry

The mailbox information (MINFO) entry creates a mail group for a mailing list. The MINFO entry is usually associated with a mail group (MG) entry, but can also be used with a mailbox (MB) entry. The following is the format of a MINFO entry:

*mailbox ttl addr-class entry-type requests maintainer*

The fields in the MINFO entry have the values described in Section G.1, with the following exceptions:

| Field             | Description  |
|-------------------|--|
| <i>mailbox</i>    | This field specifies the name of the mailbox, and its value is usually BIND.   |
| <i>requests</i>   | This field specifies the name where users can send mail relating to the DNS or mail. For example, a user might want to send a mail message requesting that an alias be set up.                             |
| <i>maintainer</i> | This field contains the login name of the person who will receive mail error messages. This is particularly useful when an error in member's names needs to be reported to a person other than the sender. |

The following is an example of a MINFO entry:

```
mailbox    ttl    addr-class  entry-type  requests    maintainer
BIND                               IN          MINFO       BIND-REQUEST
fred@miami.cities.dec.com.
```

In this example, note that the second field is blank, thus using the default *ttl* specified in the SOA entry or the *\$ttl* entry.

## G.2.10 Mail Rename Entry

The mail rename (MR) entry lists aliases for a specific user. The following is the format of an MR entry:

*alias ttl addr-class entry-type login*

The fields in the MR entry have the values described in Section G.1, with the following exceptions:

| Field        | Description  |
|--------------|--|
| <i>alias</i> | This field lists the nicknames for the specified user. The alias must be unique to the domain.   |
| <i>login</i> | This field is the login name for the user whose alias is being established. There should also be a corresponding MB entry for the specified login name. Login names must be unique for the domain. |

The following is an example of an MR entry:

```
;alias    ttl    addr-class  entry-type  login
lady      IN          MR          diana
```

```
princess      IN      MR      diana
```

This example shows how to set up the aliases lady and princess for a user whose login name is diana. Note that the second field is left blank, thus using the default ttl specified in the SOA entry or the \$ttl entry.

## G.2.11 Mail Exchanger Entry

The mail exchanger (MX) entry specifies a system in the local domain (called a gateway) that knows how to deliver mail to a system that might not be directly connected to the local network. Consequently, the MX entry is useful for systems outside your local network that want to send mail to a user on one of your network's hosts.

You can also use the MX entry to list some of the hosts in the `/etc/hosts` file so that they do not appear to other systems using the DNS service.

The following is the format of an MX entry:

```
system ttl addr-class entry-type pref-value gateway
```

The fields in the MX entry have the values described in Section G.1, with the following exceptions:

| Field             | Description   |
|-------------------|---|
| <i>system</i>     | This field specifies the name of the system where mail is to be sent.   |
| <i>pref-value</i> | This field specifies the order a mailer is to follow when there is more than one way to deliver mail to a given system.                     |
| <i>gateway</i>    | This field contains the name of the gateway system, that is, the system that can deliver mail to the destination system on another network. |

The following is an example of two MX entries:

```
;system      ttl  addr-class  entry-type  pref-value  gateway
tampa.cities.dec.com      IN      MX      0      seismo.cs.au.
*.folks.dec.com           IN      MX      0      relay.cs.net.
```

In this example, all mail destined for the domain folks.dec.com, regardless of the host name, is sent by route of the relay.cs.net host. In addition, note that the ttl field in both entries is blank, thus using the default ttl specified in the SOA entry or the \$ttl entry. The second entry uses an asterisk, which is a wildcard.

## G.2.12 Name Server Entry

The name server (NS) entry specifies that a system is a name server for the specified domain. The following is the format of the NS entry:

```
name ttl addr-class entry-type server
```

The fields in the NS entry have the values described in Section G.1, with the exception of the *server* field. This field specifies the name of the primary master server for the domain specified in the first field.

The following is an example of an NS entry:

```
;name      ttl      addr-class  entry-type  server
           IN              NS          utah.states.dec.com.
```

## G.2.13 Domain Name Pointer Entry

The domain name pointer (PTR) entry allows special names to point to some other location in the domain. PTR names must be unique to the zone. These entries are located on a primary server in the `/etc/namedb/hosts.rev` file. The following is the format of a PTR entry:

```
rev-addr ttl addr-class entry-type hostname
```

The fields in the PTR entry have the values described in Section G.1, with the following exceptions:

| Field           | Description  |
|-----------------|--|
| <i>rev-addr</i> | This field specifies the reverse IP address of the host. For example, if the host's address is 128.11.22.33, the reverse address is 33.22.11.128.  |
| <i>hostname</i> | This is the fully qualified DNS name of the host, for example, miami.cities.dec.com. Be sure to include the period (.) at the end of the host name if the host is not in the current domain. |

The following is an example of two PTR entries:

```
;rev-addr          ttl      addr-class  entry-type  hostname
33.22              IN              PTR         chicago
66.55.44.121.in-addr.arpa.  IN              PTR         mail.peace.org.
```

In this example, the first entry is for a host whose IP host address is 22.33 in the current domain. The specified `rev.addr` (33.22) is meaningful assuming that a `$origin` entry exists. See Section G.2.2 for a description of the `$origin` entry. If there is not an `$origin` entry, then the entire IP address, in reverse, must be specified.

The second entry is for a host in different domain (`mail.peace.org`). As a rule, do not do this because you are putting data in your server's cache for which your server is not authoritative. PTR entries and other resource

records are for hosts in your domain only. The PTR entry sets up a reverse pointer for the host mail.peace.org.

## G.2.14 Start of Authority Entry

The start of authority (SOA) entry designates the beginning of a zone. There can be no more than one SOA entry per zone. The following is the format of an SOA entry:

```
name ttl addr-class entry-type origin person serial# refresh retry \  
expire min
```

The forward slash (\) indicates line continuation.

The fields in the SOA entry have the values described in Section G.1, with the following exceptions:

| Field          | Description  |
|----------------|--|
| <i>origin</i>  | This field is the name of the host on which the data file resides. This is usually a master server.  |
| <i>person</i>  | This field defines the login name and mailing address of the person responsible for the DNS running on the local domain.   |
| <i>serial#</i> | <p>This field specifies the version number of the data file. The person editing the master files for the zone must increment the value in this field each time a change is made to the data within the file. The serial number being changed informs the secondary servers that there is new data to be obtained from the master server. The maximum number is <math>2^{32}-1</math> after the decimal point.</p> <p>The serial number field allows the DNS to determine which of two copies of data files in a zone are more recent. Typically, the serial number field begins at one (1) and is incremented by one each time the original data file is modified. It is best to use whole integers.</p> |
| <i>refresh</i> | <p>This field specifies how often, in seconds, a secondary DNS server is to check with the master server to see if it needs to update its data files. If the data files are out of date (as indicated by a mismatch of serial number fields), they are updated with the contents of the master server's files.</p> <p>The minimum refresh period is 30 seconds. If the refresh field is blank, however, the data file is not dynamically updated.</p>  |

| Field         | Description   |
|---------------|---|
| <i>retry</i>  | This field specifies how often, in seconds, a secondary DNS server will try to refresh its data files after a refresh failure has occurred while making the check. If a DNS server attempts to refresh the files and fails, it tries to refresh them again every so many seconds, as specified in the <i>retry</i> field. |
| <i>expire</i> | This field specifies the upper limit, in seconds, that a secondary DNS server can use the data files in its cache before the data expires for lack of being updated, or before the DNS server checks to see if its cache needs to be updated.   |
| <i>min</i>    | This field specifies the default time to live, in seconds, that a data entry can exist in the event that the <i>ttd</i> entry is left blank.  |

The following is an example of an SOA entry. The first line is a comment that shows the fields:

```

;name    ttl    addr-class  entry-type  origin                                person
@                IN          SOA         utah.states.dec.com. hes.utah.states.dec.com. (
                                1          ; serial
                                3600         ; refresh every hr.
                                300          ; retry every 5 min.
                                3600000      ; expire in 1000 hrs.
                                86400       ) ; min. life is 24 hrs.

```

In this example note that the parentheses indicate to the DNS that this is a single entry. The *ttd* field is blank, indicating that the default time to live specified in the *min* field (86400 seconds) is being used.

The semicolons allow comments for readability. In the example, the serial field is 1, the refresh field is 3600 seconds (once per hour), the *retry* field is 300 seconds (once per 5 minutes), the *expire* field is 3,600,000 seconds (1000 hours), and the *min* field is 86400 seconds (24 hours).

## G.2.15 Well Known Services Entry

The well known services (WKS) entry describes well known services supported by a particular protocol at a specified address. The services and port numbers are obtained from the list of services specified in the */etc/services* file. The following is the format of a WKS entry:

```
name ttl addr-class entry-type address protocol services
```

The fields in the WKS entry have the values described in Section G.1, with the following exceptions:

| Field           | Description   |
|-----------------|---|
| <i>address</i>  | This field specifies the IP address for each system. There can be only one WKS entry for each protocol at each address. |
| <i>protocol</i> | This field specifies the protocol to be used, for example TCP or UDP.   |

Here is an example of two WKS entries:

```

;name      ttl      addr-class  entry-type  address      protocol      services
           IN          WKS         128.32.0.4  UDP          who route
           IN          WKS         128.32.0.78 TCP          (echo talk
                                discard sunrpc sftp
                                uucp-path netstat host
                                systat daytime link
                                auth time ftp
                                nntp whois pop
                                finger smtp supdup
                                domain nameserver
                                chargen)

```

Note that the first and second fields of both entries in this example are blank, which indicates that they are using the domain name specified in a previous entry and the default ttl specified in the SOA entry or the \$ttl entry. The services listed in the second entry are contained within parentheses and are thus interpreted as being one entry, even though they appear to be on several lines.





---

# Index

## A

---

### **Access Control Lists**

( *See* ACLs )

### **ACLs**, 7–33

#### **alias database**

administering and distributing  
alias information, 7–40

#### **aliases**, 7–18, 7–40

#### **aliases file**

distributing for mail, 7–6  
entries, 4–15

#### **anonymous users**, 4–14

#### **authentication**

and DNS, 2–6, 2–21  
and NTP, 6–6

#### **authoritative server**, 11–1

#### **auto.master map**

modifying, 3–27  
removing an NFS map, 3–28

#### **autofs daemon**

and NIS, 4–2  
defined, 4–2  
error messages, C–10  
invoking, 4–23  
maps  
( *See* automount maps )  
migrating from automount, 4–25  
mounting a remote file system,  
4–19

#### **autofs mount command**

and string substitutions, A–5  
error messages, C–10  
pattern matching, A–5  
using the ampersand, A–5  
using the asterisk, A–6

#### **automount command**

and string substitutions, A–5  
pattern matching, A–5  
using the ampersand, A–5  
using the asterisk, A–6

#### **automount daemon**

and NIS, 4–2  
defined, 4–2  
error messages, C–6  
invoking, 4–23  
maps  
( *See* automount maps )  
migrating to autofs, 4–25  
mounting a remote file system,  
4–19

starting with SysMan Menu, 4–9

#### **automount maps**, 4–2, A–1

administering locally, 4–3  
administering with NIS, 4–2  
and environment variables, A–6  
and the /var/yp/Makefile file, 3–12  
creating, A–1  
direct, A–2  
distributing with NIS, 3–12  
examples, A–1  
indirect, A–3  
modifying the master map, 3–28  
replicated file systems, A–9  
specifying multiple mounts, A–7  
specifying shared mounts, A–8

## B

---

### **Berkeley Internet Name Domain**

( *See* DNS )

**BIND**

( *See* DNS )

**binmail utility**, 7–41

---

**C**

---

**caching-only server**

configuring for DNS, 2–15  
defined, 2–2

**calls**

initiating to remote hosts, 5–24

**CDSL**, 1–9**client**

autofs error messages, C–10  
autofsmount error messages, C–10  
automount error messages, C–6  
configuring for DNS, 2–20  
configuring for mail, 7–15  
configuring for NFS, 4–9  
configuring for NIS, 3–17  
configuring for NTP, 6–6  
deconfiguring for DNS, 2–29  
deconfiguring for NFS, 4–10  
delivering mail to, 7–5  
DNS, 2–2, 2–3  
mail, 7–2  
mounting a remote file system,  
4–18  
NFS, 4–1  
NFS error messages, C–2  
NFS management tasks, 4–17  
NIS, 3–1  
NIS management tasks, 3–31  
NTP, 6–2  
unmounting a remote file system,  
4–28

**cloning**

installation and configuration, 1–9

**command files (uucp)**, 5–21**Compaq Analyze**, 10–3**Compaq Insight Manager**, 1–7**configuration cloning**, 1–9**Context-Dependent Symbolic  
Link**

( *See* CDSL )

**cron daemon**

log file, 5–23  
running the uudemmon.admin script,  
5–18  
running the uudemmon.cleau script,  
5–20  
running the uudemmon.hour script,  
5–24  
scheduling uucp jobs, 5–23

---

**D**

---

**data files**

DNS, 2–5, 2–12, 2–31  
uucp, 5–21

**databases**

distributed by NIS, 3–2

**DECEvent**, 10–3**Dialcodes file**, 5–8**direct maps**

multiple mounts, A–7

**directory**

( *See* file system )

**DNS**

authoritative server, 11–1  
client, 2–3  
configuration files, 2–11  
configuration worksheet, 2–6  
configuring a caching-only server,  
2–15  
configuring a client, 2–20  
configuring a forward-only server,  
2–16  
configuring a master server, 2–9  
configuring a slave server, 2–13  
configuring a stub server, 2–18  
data file, G–1  
deconfiguring, 2–29  
determining the server type, 11–5  
enabling authentication, 2–6, 2–21  
enabling dynamic updates, 2–5,  
2–12, 2–21  
finding domain information, 11–8

- glossary of terms, 11-1
- information required for
  - configuration, 2-6
- IPv6 server guidelines, 2-11
- make command, 2-31
- master file data types, 11-1
- MX data file entry, 2-32
- named.conf file, G-1
- nslookup command, 11-20
- resolving target data, 11-20
- resource records, 2-5, 2-12, 2-31, G-1
- sample configuration, 2-2
- server testing worksheet, 11-2
- servers, 2-2
- starting server testing, 11-3
- testing forwarders, 11-10
- testing master servers, 11-15
- testing servers, 11-1
- testing slave servers, 11-11
- tracing from the root name server, 11-18
- troubleshooting, 9-4, 9-5
- updating server data files, 2-5, 2-12, 2-31
- using domain-addresses for mail, 7-5
- using mail exchanger entries, 7-5
- dohash utility**, 7-25
- domain**
  - adding an NIS map, 3-26
  - adding groups to NIS, 3-25
  - adding users to NIS, 3-23
  - finding DNS information, 11-8
  - removing NIS map from, 3-27
- domain name**
  - DNS, 2-8
  - NIS, 3-4
- Domain Name System**
  - ( *See* DNS )
- dtmail utility**, 7-42

- dynamic updates**, 2-5, 2-12

## E

---

- environment variables**, A-6
- error log file**
  - viewing, 10-3
- error messages**, 9-1
  - ( *See also* problem; troubleshooting )
  - mail, E-1
  - NFS, C-1
  - UUCP, D-1
- Event Viewer**
  - viewing syslogd message files, 10-4
- execute files (uucp)**, 5-21
- exporting file systems**, 4-12
- exports file**
  - NFS access and, 4-14
  - options, 4-14
  - security and, 4-11

## F

---

- file handle**
  - stale, 9-13
- file system**, 4-18
  - ( *See also* remote file system )
  - exporting, 4-12
  - halting export of, 4-13
- file transfer**
  - monitoring, 10-3
- files**
  - aliases, 4-15, 7-6
  - command (uucp), 5-21
  - data (uucp), 5-21
  - editing manually, 1-9
  - execute (uucp), 5-21
  - exporting, 4-12
  - exports, 4-11, 4-14
  - halting export of, 4-13
  - log (uucp), 5-21

- Maxuuscheds, 5–23
- monitoring the transfer queue, 5–17
- Poll, 5–25
- rc.config, 1–9
- removing from the uucp queue, 5–21
- svc.conf, 2–10, 2–13, 2–15, 2–18, 2–20, 2–30, 3–19

**firewall**, 7–3

**forward-only server**

- configuring for DNS, 2–16

**forward-only server**

- defined, 2–3

**forwarder**, 11–1

## G

---

**group file**

- and NIS, 3–25

**group map**, 3–25

## H

---

**host**

- adding to the mail environment, 7–18

- obtaining IP information, 2–32

**host name**

- obtaining with DNS, 2–31

**Host Resources MIB**, F–1

**hosts database**

- distributing, 4–1

## I

---

**IMAP**, 7–24

- ACLs, 7–33

- administrative tools, 7–28

- configuring user accounts, 7–25

- directory structure, 7–29

- dohash utility, 7–25

- installing, 7–24

- mailbox names, 7–32

- mailusradm utility, 7–25, 7–27

- migrating from UNIX and POP3, 7–27

- Netscape Messenger, 7–42

- partitions, 7–37

- quotas, 7–35

- troubleshooting, 9–24

- upgrading from previous versions, 7–25

**Insight Manager**, 1–7

**installation cloning**, 1–9

**Internet**

- monitoring server ports, 4–16

- selecting NTP servers, 6–4

**Internet Address Verification**

- adding, 4–9

**Internet Message Access Protocol**

- ( *See* IMAP )

**IP address**

- obtaining using DNS, 2–31

**IPv6**

- enabling DNS dynamic updates, 2–21

## J

---

**jobs**

- cleaning up undelivered, 5–21

- monitoring status, 5–17

- scheduling UUCP, 5–23

## L

---

**local host**

- obtaining NTP status from, 6–9

**log files**, 5–22, 10–4

- ( *See also* messages )

- UUCP, 5–22

## M

---

**mail**

- adding a host, 7–18

- administering aliases, 7–40
- aliasing root, 4–15
- and DECnet, 7–6
- and firewalls, 7–3
- archiving the mail queue, 7–39
- binmail, 7–41
- changing aliases database, 7–40
- configuration worksheet, 7–10
- configuring a client, 7–15
- configuring a server, 7–16
- configuring a standalone system, 7–14
- delivering to clients, 7–5
- displaying statistics, 7–41
- distributing the aliases file, 7–6
- distributing the passwd file, 7–6
- domain-based addresses, 7–5
- dtmail utility, 7–42
- error messages, E–1
- gateway, 7–4
- IMAP, 7–24
- information required for
  - configuration, 7–9
  - mailq command, 7–38
  - mailstats command, 7–41
  - mailusradm utility, 7–21, 7–25, 7–27
  - mailx utility, 7–42
  - message handler (mh) utility, 7–42
  - monitoring the queue, 7–38
  - Netscape Messenger, 7–42
  - planning, 7–8
  - POP, 7–18
  - required protocols, 7–8
  - sample configurations, 7–2
  - sending to remote superusers, 4–15
  - sendmail utility, 7–41
  - statistics file, 7–41
  - system roles, 7–2
  - troubleshooting, 9–22, 9–24
  - using DNS MX records, 7–5

- utilities, 7–41
- mail aliases**
  - distributing, 7–40
- Mail Configuration application**, 7–13
- mail host**, 7–18
- mail utility**, 7–41
- mailconfig application**, 7–13
- mailq command**, 7–38
- mailstats command**, 7–41
- mailusradm utility**, 7–21, 7–25, 7–27
- mailx utility**, 7–42
- make command**
  - and DNS, 2–31
- makedbm command**
  - building a new NIS map, 3–21
  - showing contents of NIS map, 3–21
- Makefile**
  - editing for NIS, 3–26
  - modifying for NIS, 3–28
- map**
  - ( *See* NIS map, automount maps )
- master server**
  - configuring for DNS, 2–9
  - configuring for NIS, 3–11
  - defined for DNS, 2–2
  - defined for NIS, 3–1
- Maxuuscheds file**, 5–23
- message handler (mh)**, 7–42
- messages**
  - autofsd, C–10
  - autofsmount, C–10
  - automount, C–6
  - console, C–14
  - mail, E–1
  - NFS client, C–2
  - NFS server, C–1
  - tip, D–8
  - UUCP, D–1
- MIB**

Host Resources, F-1  
**migrating**  
from automount to autofs, 4-25  
from older POP3 server, 7-19  
from POP to IMAP mail, 7-27  
**modem**  
using with UUCP, 5-3, 5-12  
**mountd daemon**  
options, 4-11  
**mounting remote file systems,**  
4-18  
**multiple mount, A-7**  
**MX records, 7-5**

## N

---

**named.conf file**  
and IPv6 server, 2-12  
**nameserver record, 11-1**  
**Network File System**  
( See NFS )  
**network groups**  
and NFS, 4-6  
**Network Information Service**  
( See NIS )  
**network problems, 9-1**  
( See also problem;  
troubleshooting )  
gathering information, 12-1  
reporting, 12-1  
tools for solving, 10-1  
**Network Setup Wizard, 1-5**  
**Network Time Protocol**  
( See NTP )  
**NFS**  
allowing client superuser access,  
4-14  
and BIND, 4-1  
and NIS, 4-1  
and superuser mail, 4-15  
and the hosts database, 4-1  
and UIDs on remotely mounted file  
systems, 4-8  
autofs, 4-2

automount, 4-2  
client, 4-1  
client error messages, C-2  
client management tasks, 4-17  
configuration worksheet, 4-3  
configuring clients, 4-9  
configuring servers, 4-8  
console error messages, C-14  
deconfiguring, 4-10  
error messages, C-1  
exporting file systems, 4-12  
halting export of file systems, 4-13  
improving file security, 4-11  
information required for  
configuration, 4-3  
monitoring server ports, 4-16  
monitoring system load, 4-16  
mountd daemon, 4-11  
mounting a remote file system,  
4-18  
nfsd daemons, 4-4  
nfsiod daemon, 4-6  
nfsstat command, 4-16  
server, 4-1  
server daemons, 4-4  
server error messages, C-1  
server management tasks, 4-11  
troubleshooting, 9-12, 9-15  
unmounting a remote file system,  
4-28  
**nfscfg application, 4-8**  
**nfsstat command, 4-16**  
**NIC whois service**  
( See whois service )  
**NIS**  
adding a slave server, 3-20, B-1  
adding groups to a domain, 3-25  
adding users to a domain, 3-23  
administering automount and  
autofs maps, 4-2  
aliases database, 7-6  
and sendmail, 7-40  
changing a password, 3-31

- client, 3-1
- configuration, 3-10
- configuration worksheet, 3-3
- configuring a client, 3-17
- configuring a master server, 3-11
- configuring a slave server, 3-15
- databases distributed by, 3-2
- distributing automount and autofs maps, 3-12
- information required for
  - configuration, 3-3
- managing a client, 3-31
- managing a server, 3-20
- modifying, 3-20
- modifying svc.conf, 3-19
- modifying the Makefile, 3-28
- obtaining map information, 3-31
- removing, 3-20
- removing a slave server, 3-22, B-2
- sample configuration, 3-1
- security, 3-6, 3-7, 3-9, 3-29
- server types, 3-1
- server update scripts, B-1
- troubleshooting, 9-6, 9-9
- updating maps, 3-25
- Yellow Pages, 3-1

**NIS map**

- adding to a domain, 3-26
- distributing, 3-26
- modifying the automount master, 3-27
- obtaining information from, 3-31
- removing from a domain, 3-27
- updating, 3-25

**nissetup command**, 3-10

**NS record**, 11-1

**nslookup command**, 2-32

- obtaining host information, 2-32
- obtaining IP information, 2-32
- solving problems using, 11-20

**NTP**

- and system security, 6-7
- authentication, 6-6
- client, 6-2
- configuration worksheet, 6-3
- configuring, 6-6
- displaying status, 6-9
- displaying xntpd status, 6-8
- information required for
  - configuration, 6-3
- Internet time servers, 6-4
- ntpq command, 6-8
- reference clock, 6-4
- sample configurations, 6-2
- server, 6-2
- troubleshooting, 9-20
- xntpd command, 6-9

**ntp command**, 6-10

**ntpdate command**, 6-10

**ntpq command**, 6-8

**ntpsetup command**, 6-6

## P

---

**passwd file**

- and NIS, 3-23
- distributing for mail, 7-6

**passwd map**, 3-23

**password**

- changing for root, 3-31
- changing in NIS, 3-31

**pattern matching**

- substitutions, A-5

**PC-NFS daemon**, 4-8

**Poll file**, 5-25

- configuration, 5-15

**POP**, 7-18

- administrative tools, 7-22
- authentication, 7-21
- directory structure, 7-23
- dtmail utility, 7-42
- installing, 7-18

mailusradm utility, 7-21, 7-27  
mh utility, 7-42  
migrating from MH POP3, 7-19  
migrating from Qualcomm POP3,  
7-20  
Netscape Messenger, 7-42  
troubleshooting, 9-24

**port monitoring**, 4-16

**Post Office Protocol**  
( *See* POP )

**problem solving**, 9-1  
( *See also* troubleshooting )  
diagnostic map, 9-1  
tools, 10-1

#### **processes**

limiting number of (UUCP), 5-23

#### **protocols**

required for mail, 7-8

## **Q**

---

#### **queue**

checking UUCP, 5-18  
mail, 7-38  
transfer, 5-17

#### **Quick Setup**, 1-4

## **R**

---

#### **rc.config file**

autofs daemon, 4-21, 4-23  
automount daemon, 4-23  
editing with rcmgr utility, 1-9

#### **reference clock**

defined, 6-4

#### **remote command execution**

UUCP, 5-1

#### **remote file system**, 4-18

( *See also* file system )  
mounting automatically, 4-19  
mounting statically, 4-18  
unmounting, 4-28

#### **remote host**

initiating UUCP calls to, 5-24

obtaining NTP status from, 6-9  
polling, 5-25

#### **remote mount error messages**, C-3

#### **replicated file systems**, A-9

#### **resource record**

data file, 2-5, 2-12, 2-31

#### **root name server**

using to trace DNS information,  
11-18

#### **root password**

changing, 3-31

## **S**

---

#### **script**

addypserver, B-1  
rmypserver, B-2  
uudemon.admin, 5-18  
uudemon.cleanu, 5-20, 5-22  
uudemon.hour, 5-24  
uudemon.poll, 5-25

#### **security**

and DNS, 2-6, 2-21  
and NIS, 3-6, 3-7, 3-9  
and NTP, 6-6  
and xntpd, 6-7  
exports file and, 4-11  
firewall, 7-3  
NIS and, 3-29  
preventing access to files, 4-13

#### **sendmail**, 7-41

aliases file, 7-40  
troubleshooting, 9-22

#### **server**, 3-1

( *See also* master server; slave  
server )  
authoritative, 11-1  
configuring an NIS master, 3-11  
configuring an NIS slave, 3-15  
configuring for DNS, 2-9, 2-13,  
2-15, 2-18  
configuring for mail, 7-16  
configuring for NFS, 4-8



- configuring for NTP, 6–6
- deconfiguring for DNS, 2–29
- deconfiguring for NFS, 4–10
- DNS, 2–2
- DNS testing, 11–1
- exporting file systems, 4–12
- halting export of file systems, 4–13
- mail, 7–2
- NFS, 4–1
- NFS daemons, 4–4
- NFS error messages, C–1
- NFS management tasks, 4–11
- NIS, 3–1
- NIS management tasks, 3–20
- NTP, 6–2
- querying time, 6–10
- updating files on (DNS), 2–5, 2–12, 2–31
- shared mounts**, A–8
- Simple Network Management Protocol**  
( *See* SNMP )
- slave server**
  - adding to an NIS domain, 3–20
  - configuring for DNS, 2–13
  - configuring for NIS, 3–15
  - defined for DNS, 2–2
  - defined for NIS, 3–1
  - removing from an NIS domain, 3–22
  - script for adding to an NIS domain, B–1
  - script for removing from an NIS domain, B–2
- SNMP**
  - configuring, 8–1
  - described, 8–1
  - Host Resources MIB, F–1
- SOA record**, 11–2
- spooling directories**, 5–19
  - cleaning up manually, 5–19
  - scheduling work in, 5–23
- UUCP, 5–19
- stale file handle** , 9–13
- start of authority record**  
( *See* SOA record )
- string substitutions**
  - automount and autofs mount commands, A–5
- stub server**
  - configuring for DNS, 2–18
  - defined, 2–2
- sulog file**
  - and UUCP, 5–23
- superuser**
  - access privileges, 4–14
  - allowing NFS access, 4–14
  - and mail, 4–15
  - log of command usage, 5–23
  - remote superuser, 4–15
- svc.conf file**
  - modifying for DNS, 2–10, 2–13, 2–15, 2–18, 2–20
  - modifying with svcsetup command, 2–30, 3–19
- svcsetup command**, 2–30, 3–19
- syslogd daemon**, 10–4  
( *See also* messages )
- SysMan Menu**, 1–2
  - adding groups to NIS, 3–25
  - adding users to NIS, 3–23
  - configuring DNS caching-only server, 2–15
  - configuring DNS client, 2–20
  - configuring DNS forward-only server, 2–16
  - configuring DNS master server, 2–9
  - configuring DNS slave server, 2–13
  - configuring DNS stub server, 2–18
  - configuring NFS client, 4–9
  - configuring NFS server, 4–8
  - configuring NIS client, 3–17

- configuring NIS master server, 3–11
- configuring NIS slave server, 3–15
- configuring NTP, 6–6
- deconfiguring DNS, 2–29
- deconfiguring NFS, 4–10
- exporting file systems, 4–12
- halting export of file systems, 4–13
- invoking, 1–2
- mounting a remote file system, 4–18
- Network Setup Wizard, 1–5
- Quick Setup, 1–2, 1–4
- unmounting a remote file system, 4–28
- viewing syslogd message files, 10–4
- system load**
  - NFS and, 4–16
- system log files**
  - ( *See* log files )
- system security**
  - ( *See* security )

## T

---

- TCP server daemon**, 4–4
- time**
  - querying, 6–10
- time servers**
  - Internet network, 6–4
- tip command**
  - error messages, D–8
- transfer queue**
  - guidelines for checking, 5–18
  - monitoring automatically, 5–18
  - monitoring manually, 5–17
- troubleshooting**, 9–1
  - DNS client, 9–5
  - DNS server, 9–4
  - IMAP, 9–24
  - mail, 9–22, 9–24, E–1
  - NFS client, 9–15, C–1
  - NFS server, 9–12, C–1
  - NIS client, 9–9

- NIS server, 9–6
- NTP, 9–20
- POP, 9–24
- UUCP, 9–17, D–1

## U

---

- UDP server daemon**, 4–4
- uerf command**, 10–3
- UNIX-to-UNIX Copy Program**
  - ( *See* UUCP )
- uucico command**, 5–15
- uucleanup command**
  - and uudemmon.cleanu script, 5–20
- UUCP**
  - cleaning spooling directories, 5–19
  - cleaning up log files, 5–21
  - cleaning up undelivered jobs, 5–21
  - configuration worksheet, 5–3, 5–6, 5–9
  - configuring, 5–12
  - configuring hardwired connections, 5–12
  - configuring incoming systems, 5–14
  - configuring modems, 5–12
  - configuring outgoing systems, 5–13
  - configuring TCP/IP, 5–12
  - error messages, D–1
  - flow control, 5–15
  - hardwired connections, 5–3, 5–12
  - HoneyDanBer version, 5–1
  - incoming systems, 5–9
  - information required for configuration, 5–3
  - information required for connections, 5–3
  - initiating calls to remote hosts, 5–24
  - limiting remote executions, 5–23
  - log files, 5–21
  - modems, 5–3, 5–12
  - monitoring a file transfer, 10–3

- monitoring the transfer queue, 5-17
- outgoing systems, 5-6
- Poll file configuration, 5-15
- polling remote hosts, 5-25
- required hardware, 5-2
- sample configurations, 5-1
- scheduling jobs, 5-23
- TCP/IP connections, 5-3, 5-12
- testing a remote connection, 10-1
- troubleshooting, 9-17
- uused command, 5-23
- uucpsetup command**, 5-12
- uudemon.admin script**, 5-18
  - monitoring uucp status, 5-18
  - running, 5-18
- uudemon.cleanu script**, 5-20
  - and log files, 5-22
  - and uucleanup command, 5-20
  - running, 5-20
- uudemon.hour script**, 5-23
  - and uudemon.poll script, 5-25
  - running, 5-24
- uudemon.poll script**, 5-25
  - and uudemon.hour script, 5-25
- uulog command**, 5-22
- uused command**, 5-23
- uustat command**, 5-17
- uutry command**, 10-1
- uuxqt**
  - limiting number of processes, 5-23

## V

---

### variables

- environment, A-6

## W

---

**whois command**, 2-32

### whois service

- using, 2-32

## X

---

**xntpd daemon**, 6-1

- ( *See also* NTP )

- and system security, 6-7

- monitoring hosts, 6-8

**xntpdc command**, 6-9

## Y

---

### Yellow Pages

- ( *See* NIS )

**ypcat command**, 3-31

**ypmatch command**, 3-31

**yppasswd command**, 3-31

### ypservers map

- showing contents of, 3-22

**ypwhich command**, 3-31